



# Configure Segment Routing for IS-IS Protocol

Integrated Intermediate System-to-Intermediate System (IS-IS), Internet Protocol Version 4 (IPv4), is a standards-based Interior Gateway Protocol (IGP). The Cisco IOS XR software implements the IP routing capabilities described in International Organization for Standardization (ISO)/International Engineering Consortium (IEC) 10589 and RFC 1995, and adds the standard extensions for single topology and multitopology IS-IS for IP Version 6 (IPv6).

This module provides the configuration information used to enable segment routing for IS-IS.



---

**Note** For additional information on implementing IS-IS on your Cisco ASR 9000 Series Router, see the *Implementing IS-IS* module in the *Cisco ASR 9000 Series Aggregation Services Router Routing Configuration Guide*.

---

- [Enabling Segment Routing for IS-IS Protocol, on page 1](#)
- [Configuring a Prefix-SID on the IS-IS Enabled Loopback Interface, on page 3](#)
- [Configuring an Adjacency SID, on page 6](#)
- [Configuring Bandwidth-Based Local UCMP, on page 13](#)
- [IS-IS Prefix Attributes for Extended IPv4 and IPv6 Reachability, on page 14](#)
- [IS-IS Multi-Domain Prefix SID and Domain Stitching: Example, on page 17](#)

## Enabling Segment Routing for IS-IS Protocol

Segment routing on the IS-IS control plane supports the following:

- IPv4 and IPv6 control plane
- Level 1, level 2, and multi-level routing
- Prefix SIDs for host prefixes on loopback interfaces
- Multiple IS-IS instances on the same loopback interface for domain border nodes
- Adjacency SIDs for adjacencies
- MPLS penultimate hop popping (PHP) and explicit-null signaling

This task explains how to enable segment routing for IS-IS.

**Before you begin**

Your network must support the MPLS Cisco IOS XR software feature before you enable segment routing for IS-IS on your router.



**Note** You must enter the commands in the following task list on every IS-IS router in the traffic-engineered portion of your network.

**SUMMARY STEPS**

1. **configure**
2. **router isis** *instance-id*
3. **address-family** { **ipv4** | **ipv6** } [ **unicast** ]
4. **metric-style wide** [ **level** { **1** | **2** }]
5. **router-id loopback** *loopback interface used for prefix-sid*
6. **segment-routing mpls**
7. **exit**
8. Use the **commit** or **end** command.

**DETAILED STEPS**

	Command or Action	Purpose
<b>Step 1</b>	<b>configure</b> <b>Example:</b>  RP/0/RSP0/CPU0:router# <b>configure</b>	Enters global configuration mode.
<b>Step 2</b>	<b>router isis</b> <i>instance-id</i> <b>Example:</b>  RP/0/RSP0/CPU0:router(config)# <b>router isis</b> <i>isp</i>	Enables IS-IS routing for the specified routing instance, and places the router in router configuration mode.  <b>Note</b> You can change the level of routing to be performed by a particular routing instance by using the <b>is-type</b> router configuration command.
<b>Step 3</b>	<b>address-family</b> { <b>ipv4</b>   <b>ipv6</b> } [ <b>unicast</b> ] <b>Example:</b>  RP/0/RSP0/CPU0:router(config-isis)# <b>address-family</b> <i>ipv4 unicast</i>	Specifies the IPv4 or IPv6 address family, and enters router address family configuration mode.
<b>Step 4</b>	<b>metric-style wide</b> [ <b>level</b> { <b>1</b>   <b>2</b> }] <b>Example:</b>  RP/0/RSP0/CPU0:router(config-isis-af)# <b>metric-style</b> <i>wide level 1</i>	Configures a router to generate and accept only wide link metrics in the Level 1 area.
<b>Step 5</b>	<b>router-id loopback</b> <i>loopback interface used for prefix-sid</i> <b>Example:</b>	Configures router ID for each address-family (IPv4/IPv6).

	Command or Action	Purpose
	<pre>RP/0/RSP0/CPU0:router(config-isis-af)#router-id loopback0</pre>	IS-IS advertises the router ID in TLVs 134 (for IPv4 address family) and 140 (for IPv6 address family). Required when traffic engineering is used.
<b>Step 6</b>	<p><b>segment-routing mpls</b></p> <p><b>Example:</b></p> <pre>RP/0/RSP0/CPU0:router(config-isis-af)# segment-routing mpls</pre>	<p>Segment routing is enabled by the following actions:</p> <ul style="list-style-type: none"> <li>• MPLS forwarding is enabled on all interfaces where IS-IS is active.</li> <li>• All known prefix-SIDs in the forwarding plain are programmed, with the prefix-SIDs advertised by remote routers or learned through local or remote mapping server.</li> <li>• The prefix-SIDs locally configured are advertised.</li> </ul>
<b>Step 7</b>	<p><b>exit</b></p> <p><b>Example:</b></p> <pre>RP/0/RSP0/CPU0:router(config-isis-af)# exit RP/0/RSP0/CPU0:router(config-isis)# exit</pre>	
<b>Step 8</b>	Use the <b>commit</b> or <b>end</b> command.	<p><b>commit</b> —Saves the configuration changes and remains within the configuration session.</p> <p><b>end</b> —Prompts user to take one of these actions:</p> <ul style="list-style-type: none"> <li>• <b>Yes</b> — Saves configuration changes and exits the configuration session.</li> <li>• <b>No</b> —Exits the configuration session without committing the configuration changes.</li> <li>• <b>Cancel</b> —Remains in the configuration session, without committing the configuration changes.</li> </ul>

**What to do next**

Configure the prefix SID.

## Configuring a Prefix-SID on the IS-IS Enabled Loopback Interface

A prefix segment identifier (SID) is associated with an IP prefix. The prefix SID is manually configured from the segment routing global block (SRGB) range of labels. A prefix SID is configured under the loopback interface with the loopback address of the node as the prefix. The prefix segment steers the traffic along the shortest path to its destination.

A prefix SID can be a node SID or an Anycast SID. A node SID is a type of prefix SID that identifies a specific node. An Anycast SID is a type of prefix SID that identifies a set of nodes, and is configured with n-flag clear.

The set of nodes (Anycast group) is configured to advertise a shared prefix address and prefix SID. Anycast routing enables the steering of traffic toward multiple advertising nodes. Packets addressed to an Anycast address are forwarded to the topologically nearest nodes.

Strict-SPF SIDs are used to forward traffic strictly along the SPF path. Strict-SPF SIDs are not forwarded to SR-TE policies. IS-IS advertises the SR Algorithm sub Type Length Value (TLV) (in the SR Router Capability SubTLV) to include both algorithm 0 (SPF) and algorithm 1 (Strict-SPF). When the IS-IS area or level is Strict-SPF TE-capable, Strict-SPF SIDs are used to build the SR-TE Strict-SPF policies. Strict-SPF SIDs are also used to program the backup paths for prefixes, node SIDs, and adjacency SIDs.



**Note** The same SRGB is used for both regular SIDs and strict-SPF SIDs.

The prefix SID is globally unique within the segment routing domain.

This task explains how to configure prefix segment identifier (SID) index or absolute value on the IS-IS enabled Loopback interface.

### Before you begin

Ensure that segment routing is enabled on the corresponding address family.

## SUMMARY STEPS

1. **configure**
2. **router isis** *instance-id*
3. **interface Loopback** *instance*
4. **address-family** { **ipv4** | **ipv6** } [ **unicast** ]
5. **prefix-sid** [**strict-spf** | **algorithm** *algorithm-number*] {**index** *SID-index* | **absolute** *SID-value*} [**n-flag-clear**] [**explicit-null** ]
6. Use the **commit** or **end** command.

## DETAILED STEPS

	Command or Action	Purpose
<b>Step 1</b>	<b>configure</b> <b>Example:</b>  RP/0/RSP0/CPU0:router# <b>configure</b>	Enters global configuration mode.
<b>Step 2</b>	<b>router isis</b> <i>instance-id</i> <b>Example:</b>  RP/0/RSP0/CPU0:router(config)# <b>router isis</b> 1	Enables IS-IS routing for the specified routing instance, and places the router in router configuration mode. <ul style="list-style-type: none"> <li>• You can change the level of routing to be performed by a particular routing instance by using the <b>is-type</b> router configuration command.</li> </ul>
<b>Step 3</b>	<b>interface Loopback</b> <i>instance</i> <b>Example:</b>	Specifies the loopback interface and instance.

	Command or Action	Purpose
	<pre>RP/0/RSP0/CPU0:router(config-isis)# interface Loopback0</pre>	
<b>Step 4</b>	<p><b>address-family</b> { <b>ipv4</b>   <b>ipv6</b> } [ <b>unicast</b> ]</p> <p><b>Example:</b></p> <p>The following is an example for ipv4 address family:</p> <pre>RP/0/RSP0/CPU0:router(config-isis-if)# address-family ipv4 unicast</pre>	<p>Specifies the IPv4 or IPv6 address family, and enters router address family configuration mode.</p>
<b>Step 5</b>	<p><b>prefix-sid</b> [<b>strict-spf</b>   <b>algorithm</b> <i>algorithm-number</i>] {<b>index</b> <i>SID-index</i>   <b>absolute</b> <i>SID-value</i>} [<b>n-flag-clear</b>] [<b>explicit-null</b> ]</p> <p><b>Example:</b></p> <pre>RP/0/RSP0/CPU0:router(config-isis-if-af)# prefix-sid index 1001</pre> <pre>RP/0/RSP0/CPU0:router(config-isis-if-af)# prefix-sid strict-spf index 101</pre> <pre>RP/0/RSP0/CPU0:router(config-isis-if-af)# prefix-sid absolute 17001</pre>	<p>Configures the prefix-SID index or absolute value for the interface.</p> <p>Specify <b>strict-spf</b> to configure the prefix-SID to use the SPF path instead of the SR-TE policy.</p> <p>Specify <b>algorithm</b> <i>algorithm-number</i> to configure SR Flexible Algorithm.</p> <p>Specify <b>index</b> <i>SID-index</i> for each node to create a prefix SID based on the lower boundary of the SRGB + the index.</p> <p>Specify <b>absolute</b> <i>SID-value</i> for each node to create a specific prefix SID within the SRGB.</p> <p>By default, the n-flag is set on the prefix-SID, indicating that it is a node SID. For specific prefix-SID (for example, Anycast prefix-SID), enter the <code>n-flag-clear</code> keyword. IS-IS does not set the N flag in the prefix-SID sub Type Length Value (TLV).</p> <p>To disable penultimate-hop-popping (PHP) and add explicit-Null label, enter <code>explicit-null</code> keyword. IS-IS sets the E flag in the prefix-SID sub TLV.</p> <p><b>Note</b> IS-IS does not advertise separate explicit-NUL or flags for regular SIDs and strict-SPF SIDs. The settings in the regular SID are used if the settings are different.</p>
<b>Step 6</b>	<p>Use the <b>commit</b> or <b>end</b> command.</p>	<p><b>commit</b> —Saves the configuration changes and remains within the configuration session.</p> <p><b>end</b> —Prompts user to take one of these actions:</p> <ul style="list-style-type: none"> <li>• <b>Yes</b> — Saves configuration changes and exits the configuration session.</li> <li>• <b>No</b> —Exits the configuration session without committing the configuration changes.</li> <li>• <b>Cancel</b> —Remains in the configuration session, without committing the configuration changes.</li> </ul>

Verify the prefix-SID configuration:

```
RP/0/RSP0/CPU0:router# show isis database verbose

IS-IS 1 (Level-2) Link State Database
LSPID                LSP Seq Num  LSP Checksum  LSP Holdtime  ATT/P/OL
router.00-00         * 0x0000039b  0xfc27        1079          0/0/0
  Area Address: 49.0001
  NLPID:           0xcc
  NLPID:           0x8e
  MT:              Standard (IPv4 Unicast)
  MT:              IPv6 Unicast
  Hostname:        router
  IP Address:      10.0.0.1
  IPv6 Address:    2001:0db8:1234::0a00:0001
  Router Cap:      10.0.0.1, D:0, S:0
    Segment Routing: I:1 V:1, SRGB Base: 16000 Range: 8000
    SR Algorithm:
      Algorithm: 0
      Algorithm: 1
<...>
Metric: 0           IP-Extended 10.0.0.1/32
  Prefix-SID Index: 1001, Algorithm:0, R:0 N:1 P:0 E:0 V:0 L:0
  Prefix-SID Index: 101, Algorithm:1, R:0 N:1 P:0 E:0 V:0 L:0
<...>
```

## Configuring an Adjacency SID

An adjacency SID (Adj-SID) is associated with an adjacency to a neighboring node. The adjacency SID steers the traffic to a specific adjacency. Adjacency SIDs have local significance and are only valid on the node that allocates them.

An adjacency SID can be allocated dynamically from the dynamic label range or configured manually from the segment routing local block (SRLB) range of labels.

Adjacency SIDs that are dynamically allocated do not require any special configuration, however there are some limitations:

- A dynamically allocated Adj-SID value is not known until it has been allocated, and a controller will not know the Adj-SID value until the information is flooded by the IGP.
- Dynamically allocated Adj-SIDs are not persistent and can be reallocated after a reload or a process restart.
- Each link is allocated a unique Adj-SID, so the same Adj-SID cannot be shared by multiple links.

Manually allocated Adj-SIDs are persistent over reloads and restarts. They can be provisioned for multiple adjacencies to the same neighbor or to different neighbors. You can specify that the Adj-SID is protected. If the Adj-SID is protected on the primary interface and a backup path is available, a backup path is installed. By default, manual Adj-SIDs are not protected.

Adjacency SIDs are advertised using the existing IS-IS Adj-SID sub-TLV. The S and P flags are defined for manually allocated Adj-SIDs.

```
0 1 2 3 4 5 6 7
```

```

+-----+
|F|B|V|L|S|P| |
+-----+
    
```

**Table 1: Adjacency Segment Identifier (Adj-SID) Flags Sub-TLV Fields**

Field	Description
S (Set)	This flag is set if the same Adj-SID value has been provisioned on multiple interfaces.
P (Persistent)	This flag is set if the Adj-SID is persistent (manually allocated).

Manually allocated Adj-SIDs are supported on point-to-point (P2P) interfaces.

This task explains how to configure an Adj-SID on an interface.

**Before you begin**

Ensure that segment routing is enabled on the corresponding address family.

Use the **show mpls label table detail** command to verify the SRLB range.

**SUMMARY STEPS**

1. **configure**
2. **router isis** *instance-id*
3. **interface** *type interface-path-id*
4. **point-to-point**
5. **address-family** { **ipv4** | **ipv6** } [ **unicast** ]
6. **adjacency-sid** { **index** *adj-SID-index* | **absolute** *adj-SID-value* } [ **protected** ]
7. Use the **commit** or **end** command.

**DETAILED STEPS**

	Command or Action	Purpose
<b>Step 1</b>	<b>configure</b> <b>Example:</b>  RP/0/RSP0/CPU0:router# <b>configure</b>	Enters global configuration mode.
<b>Step 2</b>	<b>router isis</b> <i>instance-id</i> <b>Example:</b>  RP/0/RSP0/CPU0:router(config)# <b>router isis 1</b>	Enables IS-IS routing for the specified routing instance, and places the router in router configuration mode.  • You can change the level of routing to be performed by a particular routing instance by using the <b>is-type</b> router configuration command.
<b>Step 3</b>	<b>interface</b> <i>type interface-path-id</i> <b>Example:</b>	Specifies the interface and enters interface configuration mode.

	Command or Action	Purpose
	RP/0/RSP0/CPU0:router(config-isis)# <b>interface GigabitEthernet0/0/0/7</b>	
<b>Step 4</b>	<p><b>point-to-point</b></p> <p><b>Example:</b></p> <pre>RP/0/RSP0/CPU0:router(config-isis-if)# point-to-point</pre>	Specifies the interface is a point-to-point interface.
<b>Step 5</b>	<p><b>address-family { ipv4   ipv6 } [ unicast ]</b></p> <p><b>Example:</b></p> <p>The following is an example for ipv4 address family:</p> <pre>RP/0/RSP0/CPU0:router(config-isis-if)# address-family ipv4 unicast</pre>	Specifies the IPv4 or IPv6 address family, and enters router address family configuration mode.
<b>Step 6</b>	<p><b>adjacency-sid {index <i>adj-SID-index</i>   absolute <i>adj-SID-value</i> } [protected ]</b></p> <p><b>Example:</b></p> <pre>RP/0/RSP0/CPU0:router(config-isis-if-af)# adjacency-sid index 10</pre> <pre>RP/0/RSP0/CPU0:router(config-isis-if-af)# adjacency-sid absolute 15010</pre>	<p>Configures the Adj-SID index or absolute value for the interface.</p> <p>Specify <b>index</b> <i>adj-SID-index</i> for each link to create an Adj-SID based on the lower boundary of the SRLB + the index.</p> <p>Specify <b>absolute</b> <i>adj-SID-value</i> for each link to create a specific Adj-SID within the SRLB.</p> <p>Specify if the Adj-SID is <b>protected</b>. For each primary path, if the Adj-SID is protected on the primary interface and a backup path is available, a backup path is installed. By default, manual Adj-SIDs are not protected.</p>
<b>Step 7</b>	Use the <b>commit</b> or <b>end</b> command.	<p><b>commit</b> —Saves the configuration changes and remains within the configuration session.</p> <p><b>end</b> —Prompts user to take one of these actions:</p> <ul style="list-style-type: none"> <li>• <b>Yes</b> — Saves configuration changes and exits the configuration session.</li> <li>• <b>No</b> —Exits the configuration session without committing the configuration changes.</li> <li>• <b>Cancel</b> —Remains in the configuration session, without committing the configuration changes.</li> </ul>

Verify the Adj-SID configuration:

```
RP/0/RSP0/CPU0:router# show isis segment-routing label adjacency persistent
Mon Jun 12 02:44:07.085 PDT
```

IS-IS 1 Manual Adjacency SID Table



```

15010 AF IPv4
    GigabitEthernet0/0/0/3: IPv4, Protected 1/65/N, Active
    GigabitEthernet0/0/0/7: IPv4, Protected 2/66/N, Active

15100 AF IPv6
    GigabitEthernet0/0/0/3: IPv6, Not protected 255/255/N, Active

```

Verify the labels are added to the MPLS Forwarding Information Base (LFIB):

```

RP/0/RSP0/CPU0:router# show mpls forwarding labels 15010
Mon Jun 12 02:50:12.172 PDT
Local  Outgoing  Prefix          Outgoing  Next Hop  Bytes
Label  Label      or ID           Interface  Hop       Switched
-----
15010  Pop         SRLB (idx 10)   Gi0/0/0/3  10.0.3.3  0
        Pop         SRLB (idx 10)   Gi0/0/0/7  10.1.0.5  0
        16004      SRLB (idx 10)   Gi0/0/0/7  10.1.0.5  0          (!)
        16004      SRLB (idx 10)   Gi0/0/0/3  10.0.3.3  0          (!)

```

## Protected Adjacency SID Backup Timer

IS-IS advertises a protected adjacency SID for an adjacency when a backup path is available. Primary and backup paths are programmed into the label switching database (LSD) as rewrites.

When an adjacency goes down, IS-IS stops advertising the protected adjacency SID immediately, and the backup path is promoted and installed as LSD rewrite. After a specified amount of time, the LSD rewrite is deleted. If the installed path fails again, the protection ends there and traffic through the original protected adjacency SID is permanently lost.

The Protected Adjacency SID Backup Timer provides a configurable maintenance time period. During this time period, IS-IS updates the LSD rewrite with primary and backup (if available) paths to the neighbor upon topology changes.

### Configuration

Use the **segment-routing protected-adjacency-sid-delay** command in IS-IS address family configuration mode. The range is from 30 to 3600 seconds; the default is 900 seconds (15 min).

```

Router(config)# router isis 1
Router(config-isis)# address-family ipv4 unicast
Router(config-isis-af)# segment-routing protected-adjacency-sid-delay 360

```

### Running Configuration

```

router isis 1
  address-family ipv4 unicast
    segment-routing protected-adjacency-sid-delay 360
  !
  interface GigabitEthernet0/0/0/7
    point-to-point
    address-family ipv4 unicast
      fast-reroute per-prefix
      fast-reroute per-prefix ti-lfa
    !

```

!

!

## Manually Configure a Layer 2 Adjacency SID

Typically, an adjacency SID (Adj-SID) is associated with a Layer 3 adjacency to a neighboring node, to steer the traffic to a specific adjacency. If you have Layer 3 bundle interfaces, where multiple physical interfaces form a bundle interface, the individual Layer 2 bundle members are not visible to IGP; only the bundle interface is visible.

You can configure a Layer 2 Adj-SID for the individual Layer 2 bundle interfaces. This configuration allows you to track the availability of individual bundle member links and to verify the segment routing forwarding over the individual bundle member links, for Operational Administration and Maintenance (OAM) purposes.

A Layer 2 Adj-SID can be allocated dynamically or configured manually.

- IGP dynamically allocates Layer 2 Adj-SIDs from the dynamic label range for each Layer 2 bundle member. A dynamic Layer 2 Adj-SID is not persistent and can be reallocated as the Layer 3 bundle link goes up and down.
- Manually configured Layer 2 Adj-SIDs are persistent if the Layer 3 bundle link goes up and down. Layer 2 Adj-SIDs are allocated from the Segment Routing Local Block (SRLB) range of labels. However, if the configured value of Layer 2 Adj-SID does not fall within the available SRLB, a Layer 2 Adj-SID will not be programmed into forwarding information base (FIB).

### Restrictions

- Adj-SID forwarding requires a next-hop, which can be either an IPv4 address or an IPv6 address, but not both. Therefore, manually configured Layer 2 Adj-SIDs are configured per address-family.
- Manually configured Layer 2 Adj-SID can be associated with only one Layer 2 bundle member link.
- A SID value used for Layer 2 Adj-SID cannot be shared with Layer 3 Adj-SID.
- SR-TE using Layer 2 Adj-SID is not supported.

This task explains how to configure a Layer 2 Adj-SID on an interface.

### Before you begin

Ensure that segment routing is enabled on the corresponding address family.

Use the **show mpls label table detail** command to verify the SRLB range.

### SUMMARY STEPS

1. **configure**
2. **segment-routing**
3. **adjacency-sid**
4. **interface** *type interface-path-id*
5. **address-family** { **ipv4** | **ipv6** } [ **unicast** ]
6. **l2-adjacency sid** { **index** *adj-SID-index* | **absolute** *adj-SID-value* } [ **next-hop** { *ipv4\_address* | *ipv6\_address* } ]
7. Use the **commit** or **end** command.
8. **end**

9. `router isis instance-id`
10. `address-family { ipv4 | ipv6 } [ unicast ]`
11. `segment-routing bundle-member-adj-sid`

**DETAILED STEPS**

	Command or Action	Purpose
<b>Step 1</b>	<p><b>configure</b></p> <p><b>Example:</b></p> <pre>RP/0/RSP0/CPU0:router# configure</pre>	Enters global configuration mode.
<b>Step 2</b>	<p><b>segment-routing</b></p> <p><b>Example:</b></p> <pre>Router(config)# segment-routing</pre>	Enters segment routing configuration mode.
<b>Step 3</b>	<p><b>adjacency-sid</b></p> <p><b>Example:</b></p> <pre>Router(config-sr)# adjacency-sid</pre>	Enters adjacency SID configuration mode.
<b>Step 4</b>	<p><b>interface type interface-path-id</b></p> <p><b>Example:</b></p> <pre>Router(config-sr-adj)# interface GigabitEthernet0/0/0/3</pre>	Specifies the interface and enters interface configuration mode.
<b>Step 5</b>	<p><b>address-family { ipv4   ipv6 } [ unicast ]</b></p> <p><b>Example:</b></p> <pre>Router(config-sr-adj-intf)# address-family ipv4 unicast</pre>	Specifies the IPv4 or IPv6 address family, and enters router address family configuration mode.
<b>Step 6</b>	<p><b>l2-adjacency sid {index adj-SID-index   absolute adj-SID-value } [next-hop {ipv4_address   ipv6_address } ]</b></p> <p><b>Example:</b></p> <pre>Router(config-sr-adj-intf-af)# l2-adjacency sid absolute 15015 next-hop 10.1.1.4</pre>	<p>Configures the Adj-SID index or absolute value for the interface.</p> <p>Specify <b>index</b> <i>adj-SID-index</i> for each link to create an Adj-SID based on the lower boundary of the SRLB + the index.</p> <p>Specify <b>absolute</b> <i>adj-SID-value</i> for each link to create a specific Adj-SID within the SRLB.</p> <p>For point-to-point interfaces, you are not required to specify a next-hop. However, if you do specify the next-hop, the Layer 2 Adj-SID will be used only if the specified next-hop matches the neighbor address.</p> <p>For LAN interfaces, you must configure the next-hop IPv4 or IPv6 address. If you do not configure the next-hop, the Layer 2 Adj-SID will not be used for LAN interface.</p>

	Command or Action	Purpose
Step 7	Use the <b>commit</b> or <b>end</b> command.	<p><b>commit</b> —Saves the configuration changes and remains within the configuration session.</p> <p><b>end</b> —Prompts user to take one of these actions:</p> <ul style="list-style-type: none"> <li>• <b>Yes</b> — Saves configuration changes and exits the configuration session.</li> <li>• <b>No</b> —Exits the configuration session without committing the configuration changes.</li> <li>• <b>Cancel</b> —Remains in the configuration session, without committing the configuration changes.</li> </ul>
Step 8	<b>end</b>	
Step 9	<p><b>router isis</b> <i>instance-id</i></p> <p><b>Example:</b></p> <pre>Router(config)# router isis isp</pre>	Enables IS-IS routing for the specified routing instance, and places the router in router configuration mode.
Step 10	<p><b>address-family</b> { <b>ipv4</b>   <b>ipv6</b> } [ <b>unicast</b> ]</p> <p><b>Example:</b></p> <pre>Router(config-isis)# address-family ipv4 unicast</pre>	Specifies the IPv4 or IPv6 address family, and enters router address family configuration mode.
Step 11	<p><b>segment-routing bundle-member-adj-sid</b></p> <p><b>Example:</b></p> <pre>Router(config-isis-af)# segment-routing bundle-member-adj-sid</pre>	<p>Programs the dynamic Layer 2 Adj-SIDs, and advertises both manual and dynamic Layer 2 Adj-SIDs.</p> <p><b>Note</b> This command is not required to program manual L2 Adj-SID, but is required to program the dynamic Layer 2 Adj-SIDs and to advertise both manual and dynamic Layer 2 Adj-SIDs.</p>

Verify the configuration:

```
Router# show mpls forwarding detail | i "Pop|Outgoing Interface|Physical Interface"
Tue Jun 20 06:53:51.876 PDT
. . .
15001 Pop          SRLB (idx 1)      BE1          10.1.1.4      0
   Outgoing Interface: Bundle-Ether1 (ifhandle 0x000000b0)
   Physical Interface: GigabitEthernet0/0/0/3 (ifhandle 0x000000b0)
```

```
Router# show running-config segment-routing
Tue Jun 20 07:14:25.815 PDT
segment-routing
 adjacency-sid
 interface GigabitEthernet0/0/0/3
  address-family ipv4 unicast
  l2-adjacency-sid absolute 15015 next-hop 10.1.1.4
```

```

!
!
!
!

```

## Configuring Bandwidth-Based Local UCMP

Bandwidth-based local Unequal Cost Multipath (UCMP) allows you to enable UCMP functionality locally between Equal Cost Multipath (ECMP) paths based on the bandwidth of the local links.

Bandwidth-based local UCMP is performed for prefixes, segment routing Adjacency SIDs, and Segment Routing label cross-connects installed by IS-IS, and is supported on any physical or virtual interface that has a valid bandwidth.

For example, if the capacity of a bundle interface changes due to the link or line card up/down event, traffic continues to use the affected bundle interface regardless of the available provisioned bundle members. If some bundle members were not available due to the failure, this behavior could cause the traffic to overload the bundle interface. To address the bundle capacity changes, bandwidth-based local UCMP uses the bandwidth of the local links to load balance traffic when bundle capacity changes.

### Before you begin

### SUMMARY STEPS

1. **configure**
2. **router isis** *instance-id*
3. **address-family** { **ipv4** | **ipv6** } [ **unicast** ]
4. **apply-weight ecmp-only bandwidth**
5. Use the **commit** or **end** command.

### DETAILED STEPS

	Command or Action	Purpose
Step 1	<b>configure</b> <b>Example:</b> RP/0/RSP0/CPU0:router# <b>configure</b>	Enters global configuration mode.
Step 2	<b>router isis</b> <i>instance-id</i> <b>Example:</b> RP/0/RSP0/CPU0:router(config)# <b>router isis 1</b>	Enables IS-IS routing for the specified routing instance, and places the router in router configuration mode.  You can change the level of routing to be performed by a particular routing instance by using the <b>is-type</b> router configuration command.
Step 3	<b>address-family</b> { <b>ipv4</b>   <b>ipv6</b> } [ <b>unicast</b> ] <b>Example:</b> The following is an example for ipv4 address family:	Specifies the IPv4 or IPv6 address family, and enters IS-IS address family configuration mode.

	Command or Action	Purpose
	RP/0/RSP0/CPU0:router(config-isis)# <b>address-family ipv4 unicast</b>	
<b>Step 4</b>	<b>apply-weight ecmp-only bandwidth</b>  <b>Example:</b>  RP/0/RSP0/CPU0:router(config-isis-af)# <b>apply-weight ecmp-only bandwidth</b>	Enables UCMP functionality locally between ECMP paths based on the bandwidth of the local links.
<b>Step 5</b>	Use the <b>commit</b> or <b>end</b> command.	<b>commit</b> —Saves the configuration changes and remains within the configuration session.  <b>end</b> —Prompts user to take one of these actions: <ul style="list-style-type: none"> <li>• <b>Yes</b> — Saves configuration changes and exits the configuration session.</li> <li>• <b>No</b> —Exits the configuration session without committing the configuration changes.</li> <li>• <b>Cancel</b> —Remains in the configuration session, without committing the configuration changes.</li> </ul>

## IS-IS Prefix Attributes for Extended IPv4 and IPv6 Reachability

The following sub-TLVs support the advertisement of IPv4 and IPv6 prefix attribute flags and the source router ID of the router that originated a prefix advertisement, as described in RFC 7794.

- Prefix Attribute Flags
- IPv4 and IPv6 Source Router ID

### Prefix Attribute Flags

The Prefix Attribute Flag sub-TLV supports the advertisement of attribute flags associated with prefix advertisements. Knowing if an advertised prefix is directly connected to the advertising router helps to determine how labels that are associated with an incoming packet should be processed.

This section describes the behavior of each flag when a prefix advertisement is learned from one level to another.



**Note** Prefix attributes are only added when wide metric is used.

#### Prefix Attribute Flags Sub-TLV Format

0 1 2 3 4 5 6 7 ...

```

+-----+-----+-----+...
|X|R|N|           ...
+-----+-----+-----+...

```

### Prefix Attribute Flags Sub-TLV Fields

Field	Description
X (External Prefix Flag)	This flag is set if the prefix has been redistributed from another protocol. The value of the flag is preserved when the prefix is propagated to another level.
R (Re-advertisement Flag)	This flag is set to 1 by the Level 1-2 router when the prefix is propagated between IS-IS levels (from Level 1 to Level 2, or from Level 2 to Level 1).  This flag is set to 0 when the prefix is connected locally to an IS-IS-enabled interface (regardless of the level configured on the interface).
N (Node Flag)	For prefixes that are propagated from another level: <ol style="list-style-type: none"> <li>Copy the N-flag from the prefix attribute sub-TLV, if present in the source level.</li> <li>Copy the N-flag from the prefix-SID sub-TLV, if present in the source level.</li> <li>Otherwise, set to 0.</li> </ol> For connected prefixes: <ol style="list-style-type: none"> <li>Set to 0 if <b>prefix-attributes n-flag-clear</b> is configured (see <a href="#">Configuring Prefix Attribute N-flag-clear</a>).</li> <li>Set to 0 if <b>n-flag-clear { n-flag-clearSID-index   n-flag-clearSID-value }</b> <b>n-flag-clear</b> is configured (see <a href="#">Configuring a Prefix-SID on the IS-IS Enabled Loopback Interface</a>).</li> <li>Otherwise, set to 1 when the prefix is a host prefix (/32 for IPv4, /128 for IPv6) that is associated with a loopback address.</li> </ol> <p><b>Note</b> If the flag is set and the prefix length is not a host prefix, then the flag must be ignored.</p>

## IPv4 and IPv6 Source Router ID

The Source Router ID sub-TLV identifies the source of the prefix advertisement. The IPv4 and IPv6 source router ID is displayed in the output of the **show isis database verbose** command.

The Source Router ID sub-TLV is added when the following conditions are met:

- The prefix is locally connected.
- The N-flag is set to 1 (when it's a host prefix and the **n-flag-clear** configuration is not used).
- The router ID is configured in the corresponding address family.

The source router ID is propagated between levels.

Table 2: Source Router Sub-TLV Format

IPv4 Source Router ID	Type: 11 Length: 4 Value: IPv4 Router ID of the source of the prefix advertisement
IPv6 Source Router ID	Type: 12 Length: 16 Value: IPv6 Router ID of the source of the prefix advertisement

## Configuring Prefix Attribute N-flag-clear

The N-flag is set to 1 when the prefix is a host prefix (/32 for IPV4, /128 for IPV6) that is associated with a loopback address. The advertising router can be configured to not set this flag. This task explains how to clear the N-flag.

### SUMMARY STEPS

1. **configure**
2. **router isis** *instance-id*
3. **interface Loopback** *instance*
4. **prefix-attributes n-flag-clear** [Level-1 | Level-2]
5. Use the **commit** or **end** command.

### DETAILED STEPS

	Command or Action	Purpose
<b>Step 1</b>	<b>configure</b> <b>Example:</b>  RP/0/RSP0/CPU0:router# <b>configure</b>	Enters global configuration mode.
<b>Step 2</b>	<b>router isis</b> <i>instance-id</i> <b>Example:</b>  RP/0/RSP0/CPU0:router(config)# <b>router isis 1</b>	
<b>Step 3</b>	<b>interface Loopback</b> <i>instance</i> <b>Example:</b>  RP/0/RSP0/CPU0:router(config)# <b>interface Loopback0</b>	Specifies the loopback interface.
<b>Step 4</b>	<b>prefix-attributes n-flag-clear</b> [Level-1   Level-2] <b>Example:</b>	Clears the prefix attribute N-flag explicitly.



	Command or Action	Purpose
	RP/0/RSP0/CPU0:router(config-if)# <b>isis prefix-attributes n-flag-clear</b>	
<b>Step 5</b>	Use the <b>commit</b> or <b>end</b> command.	<p><b>commit</b> —Saves the configuration changes and remains within the configuration session.</p> <p><b>end</b> —Prompts user to take one of these actions:</p> <ul style="list-style-type: none"> <li>• <b>Yes</b> — Saves configuration changes and exits the configuration session.</li> <li>• <b>No</b> —Exits the configuration session without committing the configuration changes.</li> <li>• <b>Cancel</b> —Remains in the configuration session, without committing the configuration changes.</li> </ul>

Verify the prefix attribute configuration:

```
RP/0/RSP0/CPU0:router# show isis database verbose

IS-IS 1 (Level-2) Link State Database
LSPID                LSP Seq Num  LSP Checksum  LSP Holdtime  ATT/P/OL
router.00-00         * 0x0000039b  0xfc27        1079          0/0/0
  Area Address: 49.0001
  NLPID:            0xcc
  NLPID:            0x8e
  MT:              Standard (IPv4 Unicast)
  MT:              IPv6 Unicast                      0/0/0
  Hostname:        router
  IP Address:      10.0.0.1
  IPv6 Address:    2001:0db8:1234::0a00:0001
  Router Cap:      10.0.0.1, D:0, S:0
  Segment Routing: I:1 V:1, SRGB Base: 16000 Range: 8000
  SR Algorithm:
    Algorithm: 0
    Algorithm: 1
<...>
Metric: 0           IP-Extended 10.0.0.1/32
  Prefix-SID Index: 1001, Algorithm:0, R:1 N:0 P:1 E:0 V:0 L:0
  Prefix Attribute Flags: X:0 R:1 N:0
Metric: 10          IP-Extended 10.0.0.2/32
  Prefix-SID Index: 1002, Algorithm:0, R:0 N:1 P:0 E:0 V:0 L:0
  Prefix Attribute Flags: X:0 R:0 N:1
  Source Router ID: 10.0.0.2
<...>
```

## IS-IS Multi-Domain Prefix SID and Domain Stitching: Example

IS-IS Multi-Domain Prefix SID and Domain Stitching allows you to configure multiple IS-IS instances on the same loopback interface for domain border nodes. You specify a loopback interface and prefix SID under multiple IS-IS instances to make the prefix and prefix SID reachable in different domains.

This example uses the following topology. Node 5 and 9 are border nodes between two IS-IS domains (Domain1 and Domain2). Node 10 is configured as the Segment Routing Path Computation Element (SR-PCE).

Figure 1: Multi-Domain Topology

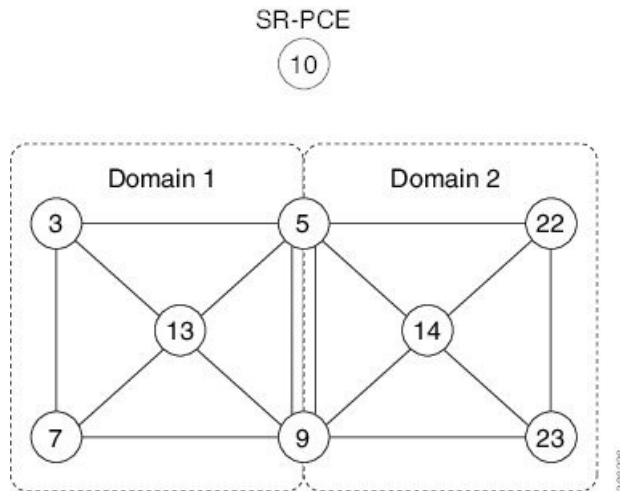

## Configure IS-IS Multi-Domain Prefix SID

Specify a loopback interface and prefix SID under multiple IS-IS instances on each border node:

```

Example: Border Node 5
router isis Domain1
 interface Loopback0
  address-family ipv4 unicast
  prefix-sid absolute 16005

router isis Domain2
 interface Loopback0
  address-family ipv4 unicast
  prefix-sid absolute 16005

```

```

Example: Border Node 9
router isis Domain1
 interface Loopback0
  address-family ipv4 unicast
  prefix-sid absolute 16009

router isis Domain2
 interface Loopback0
  address-family ipv4 unicast
  prefix-sid absolute 16009

```

Border nodes 5 and 9 each run two IS-IS instances (Domain1 and Domain2) and advertise their Loopback0 prefix and prefix SID in both domains.

Nodes in both domains can reach the border nodes by using the same prefix and prefix SID. For example, Node 3 and Node 22 can reach Node 5 using prefix SID 16005.

## Configure Common Router ID

On each border node, configure a common TE router ID under each IS-IS instance:

**Example: Border Node 5**

```
router isis Domain1
 address-family ipv4 unicast
  router-id loopback0

router isis Domain2
 address-family ipv4 unicast
  router-id loopback0
```

**Example: Border Node 9**

```
router isis Domain1
 address-family ipv4 unicast
  router-id loopback0

router isis Domain2
 address-family ipv4 unicast
  router-id loopback0
```

## Distribute IS-IS Link-State Data

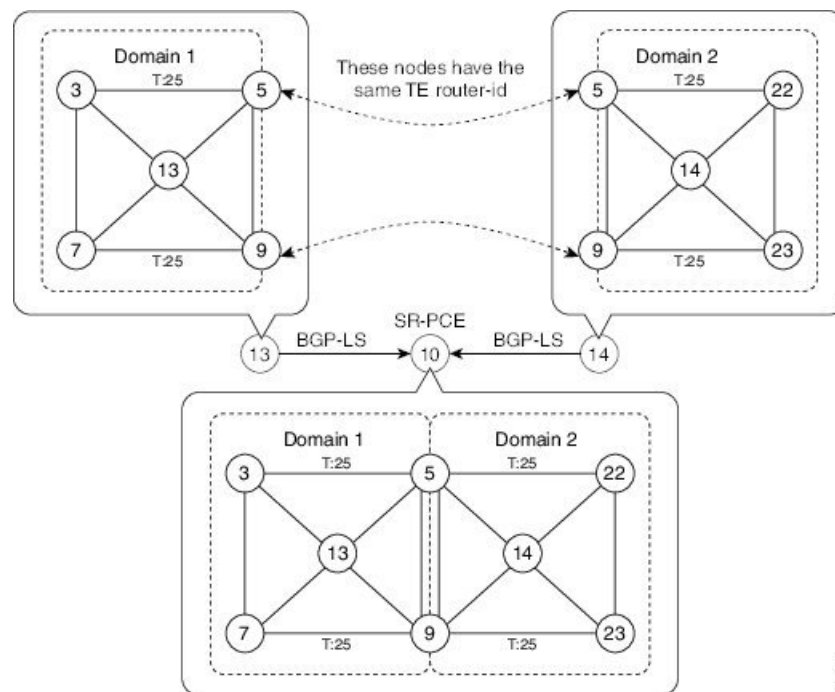

Configure BGP Link-state (BGP-LS) on Node 13 and Node 14 to report their local domain to Node 10:

**Example: Node 13**

```
router isis Domain1
 distribute link-state instance-id instance-id
```

**Example: Node 14**

```
router isis Domain2
  distribute link-state instance-id instance-id
```

Link-state ID starts from 32. One ID is required per IGP domain. Different domain IDs are essential to identify that the SR-TE TED belongs to a particular IGP domain.

Nodes 13 and 14 each reports its local domain in BGP-LS to Node 10.

Node 10 identifies the border nodes (Nodes 5 and 9) by their common advertised TE router ID, then combines (stitches) the domains on these border nodes for end-to-end path computations.