



Installing the Cisco ASR 901 Mobile Wireless Router as a Satellite Shelf

The chapter describes how to install the Cisco ASR 901 router as a satellite shelf, and how to connect it to networks and external devices. These procedures are described in the following sections:



Danger

Only trained and qualified personnel should be allowed to install, replace, or service this equipment. Statement 1030



Danger

This unit is intended for installation in restricted access areas. A restricted access area can be accessed only through the use of a special tool, lock and key, or other means of security. Statement 1017

- [Safety Guidelines, on page 1](#)
- [Prerequisites, on page 4](#)
- [Site Planning, on page 4](#)
- [Console Port Considerations, on page 8](#)
- [Network Modules, on page 9](#)
- [Mounting the Cisco ASR 901 Router, on page 9](#)
- [Connecting the Chassis Ground and Power, on page 13](#)
- [Installing and Removing SFP Modules, on page 17](#)
- [Connecting Cables, on page 19](#)
- [Powering On the Router, on page 24](#)

Safety Guidelines

Before you begin installing the Cisco ASR 901 router, review the safety guidelines and rack-mounting configuration guidelines in the [Cisco ASR 901 Series Aggregation Services Router Hardware Installation Guide](#) to avoid injuries or damaging the equipment.

In addition, before replacing, configuring, or maintaining the Cisco ASR 901 router, review the safety warnings listed in the document *Cisco Regulatory Compliance and Safety Information for Cisco ASR 901 Series Aggregation Services Router*.

Safety with Equipment

The following guidelines help ensure your safety and protect the equipment. This list does not include all the potentially hazardous situations, so be alert.

**Warning**

Read the installation instructions before connecting the system to the power source. Statement 1004

- Before moving the system, always disconnect all the power cords and interface cables.
- Never assume that power is disconnected from a circuit; always check.
- Before and after installation, keep the chassis area clean and dust-free.
- Keep tools and assembly components away from walk areas to avoid tripping over them.
- Do not work alone in potentially hazardous conditions.
- Do not perform any action that creates a potential hazard to people or makes the equipment unsafe.
- Do not wear loose clothing that may get caught in the chassis.
- When working under conditions hazardous to your eyes, wear safety glasses.

Safety with Electricity

**Warning**

Before performing any of the following procedures, ensure that power is removed from the DC circuit. Statement 1003

**Warning**

This unit is intended for installation in restricted access areas. A restricted access area can be accessed only through the use of a special tool, lock and key, or other means of security. Statement 1017

**Warning**

To avoid electric shock, do not connect safety extra-low voltage (SELV) circuits to telephone-network voltage (TNV) circuits. LAN ports contain SELV circuits, and WAN ports contain TNV circuits. Some LAN and WAN ports both use RJ-45 connectors. Statement 1021

**Warning**

Before working on equipment that is connected to power lines, remove jewelry (including rings, necklaces, and watches). Metal objects will heat up when connected to power and ground and can cause serious burns or weld the metal object to the terminals. Statement 43

**Warning**

Before working on a chassis or working near power supplies, unplug the power cord on AC units; disconnect the power at the circuit breaker on DC units. Statement 12

**Warning**

Avoid using or servicing any equipment that has outdoor connections during an electrical storm. There may be a risk of electric shock from lightning. Statement 1088

**Warning**

There is the danger of explosion if the battery is replaced incorrectly. Replace the battery only with the same or equivalent type recommended by the manufacturer. Dispose of used batteries according to the manufacturer's instructions. Statement 1015

**Warning**

This unit might have more than one power supply connection. All connections must be removed to de-energize the unit. Statement 1028

When working on electrical equipment, follow these guidelines:

- Locate the room's emergency power switch. If an electrical accident occurs, you can quickly switch off the power.
- Before working on the system, switch off the DC main circuit breaker and disconnect the power terminal block cable.
- Disconnect all power before performing the following:
 - Working on or near power supplies.
 - Installing or removing a router chassis, or network processor module.
 - Performing most hardware upgrades.
- Never install equipment that appears damaged.
- Carefully examine your work area for possible hazards, such as wet floors, ungrounded power extension cables, and missing safety grounds.
- Never assume that power is disconnected from a circuit; always check.
- Never perform any action that creates a potential hazard to people or makes the equipment unsafe.
- If an electrical accident occurs, proceed as follows:
 - Use caution, and do not become a victim yourself.
 - Switch off power to the router.
 - If possible, send another person to get medical aid. Otherwise, determine the condition of the victim, and then call for help.
 - Determine whether the person needs rescue breathing or external cardiac compressions; then take appropriate action.

In addition, use the following guidelines when working with any equipment that is disconnected from a power source, but still connected to telephone wiring or network cabling:

- Never install telephone wiring during a lightning storm.
- Never install telephone jacks in wet locations unless the jack is specifically designed for it.
- Never touch un-insulated telephone wires or terminals unless the telephone line is disconnected at the network interface.
- When installing or modifying telephone lines, use caution.

Preventing Electrostatic Discharge Damage

Electrostatic Discharge (ESD) can damage equipment and impair electrical circuitry. ESD can occur when electronic printed circuit cards are improperly handled, and can cause complete or intermittent failures. When removing and replacing modules, always follow ESD prevention procedures:

- Ensure that the router chassis is electrically connected to earth ground.
- Wear an ESD-preventive wrist strap, ensuring that it makes good skin contact. To channel unwanted ESD voltages safely to ground, connect the clip to an unpainted surface of the chassis frame. To guard against ESD damage and shocks, the wrist strap and cord must operate effectively.
- If no wrist strap is available, ground yourself by touching a metal part of the chassis.

**Caution**

For the safety of your equipment, periodically check the resistance value of the antistatic wrist strap. It should be between 1 and 10 Mohm.

Prerequisites

Before installing the Cisco ASR 901 router, it is important to prepare for installation by:

- Preparing the site (site planning) and reviewing the installation plans or method of procedures (MOPs).
- Unpacking and inspecting the Cisco ASR 901 router.
- Gathering tools and test equipment required to properly install the Cisco ASR 901 router.

Site Planning

Ideally, you should have prepared the installation site beforehand. As part of your preparation, obtain a floor plan of the site and the equipment rack where the Cisco ASR 901 router would be housed. Determine the location of any existing routers and their interconnections, including communications and power. Following the airflow guidelines (see the [Airflow Guidelines, on page 5](#)), ensure that adequate cooling air is provided to the router.

All personnel involved in the installation of the router including installers, engineers, and supervisors should participate in the preparation of a Method of Procedure (MOP) for approval by the customer.

Power Supply Considerations

Check the power at your site to ensure that you are receiving clean power (free of spikes and noise). Install a power conditioner if necessary (see the [Cisco ASR 901 Power Specifications](#) for power requirements).

**Warning**

This equipment has been designed for connection to TN and IT power systems. Statement 1007

Site Environment

Install the Cisco ASR 901 router in an equipment rack. The location of your router and the layout of your equipment rack, or wiring room are extremely important considerations for proper operation. Cramped equipment, inadequate ventilation, and inaccessible panels can cause malfunctions and shutdown and can make maintenance difficult. Plan to access the front and rear panels of the router.

Take the following precautions for an acceptable operating environment for your router and to avoid environmentally caused equipment failures:

- Ensure that the room where your router operates has adequate air circulation. Electrical equipment generates heat. Without adequate circulation, ambient air temperature may not cool the equipment to acceptable operating temperatures.
- Always follow ESD-prevention procedures described in the [Preventing Electrostatic Discharge Damage, on page 4](#) to avoid damage to equipment. Damage from static discharge can cause immediate or intermittent equipment failure.

Airflow Guidelines

To ensure adequate airflow through the equipment rack, we recommend that you maintain a clearance of at least 6 inches (15.24 cm) on each side of the rack at all times.



Caution

If airflow through the equipment rack and the routers that occupy it is blocked or restricted, or if the ambient air being drawn into the rack is too warm, an over temperature condition can occur within the rack and the routers that occupy it.

The site should also be as dust-free as possible. Dust tends to clog the router fans, reducing the flow of cooling air through the equipment rack and the routers. Thus, increasing the risk of an over temperature condition.

Use the following guidelines to plan your equipment rack configuration:

- Mount the Cisco ASR 901 router in a 19-inch rack (with a 17.5- or 17.75-inch opening).
- Beside airflow, you must allow clearance around the rack for maintenance.
- Enclosed racks must have adequate ventilation. Ensure that the rack is not congested, because each router generates heat. An enclosed rack should have louvered sides and a fan to provide cooling air. Heat that is generated by equipment near the bottom of the rack can be drawn upward into the intake ports of the equipment above.
- When mounting a chassis in an open rack, ensure that the rack frame does not block the intakes or (on the left side of the chassis) or the exhaust (on the right side of the chassis).
- When a rack-installed equipment fails, especially equipment in an enclosed rack, try making the equipment operate by itself, if possible. Power off other equipment in the rack (and in adjacent racks) to give the router a maximum of cooling air and clean power.

Method of Procedure

Part of site preparation includes reviewing installation plans or method of procedures (MOPs). An example of a MOP that includes pre-installation checklist of tasks, considerations to address and agree upon before proceeding with the installation, is as follows:

1. Read this hardware installation guide.

2. Assign personnel.
3. Determine protection requirements for personnel, equipment, and tools.
4. Evaluate potential hazards that may affect service.
5. Schedule time for installation.
6. Determine space requirements.
7. Determine power requirements.
8. Identify required procedures or tests.
9. On an equipment plan, make a preliminary decision that locates each Cisco ASR 901 router that you plan to install.
10. Verify the list of replaceable parts for installation (screws, bolts, washers, and so on) so that the parts are identified.
11. Check the required tools list to make sure the necessary tools and test equipment are available (see the [Required Tools and Equipment, on page 7](#) section).
12. Perform the installation.

Unpacking and Checking the Contents of Your Shipment

The shipping package for the Cisco ASR 901 router is designed to reduce the possibility of product damage associated with routine handling experienced during shipment. Do not remove the router from its shipping container until you are ready to install it.



Note Do not discard the packaging materials used in shipping your Cisco ASR 901 router. You will need the packaging materials in the future if you move or ship the router.

The Cisco ASR 901 router, cables, and any optional equipment you ordered may be shipped in more than one container. When you unpack the containers, check the packing list to ensure that you receive all of the following items:

- Router
- Accessory kit (part number 53-3085-01/53-3295-0 for the Cisco ASR 901), containing
 - Terminal block (part number 53-3085-01)
 - Two hole lug, 6-AWG ground wire, #10 blue stud (part number 32-0629-01)
 - Two pan-head Phillips screws used to attach the lug to the router, M5.0x10mm
 - Two cable guides (part number 700-01663-01)
 - Two pan-head Phillips screws used to attach the cable guides, M4,0x20mm (part number 48-0654-01)



Note There is no AC power option.

- Cisco Information Packet publication

Inspect all items for shipping damage. If an item appears to be damaged, or if you encounter problems installing or configuring your router, contact customer service. The Cisco Information Packet provides warranty, service, and support information.

Required Tools and Equipment

You need the following tools and equipment to install and upgrade the router and its components:



Danger

Only trained and qualified personnel should be allowed to install, replace, or service this equipment. Statement 1030

- ESD-preventive cord and wrist strap.
- Number 2 Phillips screwdriver.
- Flat-blade screwdrivers: small, 3/16-inch (0.476 cm) and medium, 1/4-inch (0.625 cm).
 - To install or remove modules
 - To remove the cover, if you are upgrading memory or other components
- Number 12-24 pan-head screws to secure the router to the equipment rack.
- Cables for connection to the WAN and LAN ports (depending on the configuration).



Note

For more information on cable specifications, see the [Dressing Router Cables, on page 24](#).

- Ethernet hub or PC with a network interface card for connection to the Ethernet (LAN) ports.
- Console terminal (an ASCII terminal or a PC running terminal emulation software) is configured for 9600 baud, 8 data bits, no parity, and 2 stop bits.
- Console cable for connection to the console port.
- Ratcheting torque screwdriver with a Phillips head that exerts up to 15 pound-force inches (lbf-in) of pressure.
- Crimping tool as specified by the ground lug manufacturer.
- 16-AWG copper wire for the power cord.
- Wire-stripping tools for stripping both 6-AWG and 18-AWG wire.
- Serial interfaces may require a channel service unit/data service unit (CSU/DSU).

Installation Checklist

To assist you with your installation and to provide a historical record of completed tasks and users, use the following installation checklist. Make a copy of this checklist and mark the entries as you complete each task. When the checklist is completed, include a copy of the checklist for each router in your site log along with other records for your new router. See [Site Log](#) for information on the site log, including a sample site log.

Installation Checklist for Site:

Router Name:

Task	Verified by	Date
Installation checklist copied		
Background information placed in site log		
Site power voltages verified		

Task	Verified by	Date
Installation site power check completed		
Required tools available		
Additional equipment available		
Router received		
Documentation DVD received (if ordered)		
Cisco Information Packet publication received		
Chassis components verified		
Initial electrical connections established		
ASCII terminal (for local configuration) or modem (for remote configuration)		
Signal distance limits verified		
Startup sequence steps completed		
Initial operation verified		
Software image verified		

Creating a Site Log

The site log provides a record of all actions related to installing and maintaining the router. Keep it in an accessible place near the chassis so that anyone who performs tasks has access to it.

Create the site log prior to installation. (See [Site Log](#) for more detailed information on the site log as well as a sample site log that can be used to make copies.)

Console Port Considerations

The Cisco ASR 901 router provides a single console port (labeled CONSOLE). A single RJ-45 cable is used for a console connection.

This section describes important cabling information to consider before connecting a console terminal—either an ASCII terminal or a PC running terminal emulation software—or a modem to the console port. The console port provides access to the router either locally (using a console terminal) or remotely (using a modem).



Note The Cisco ASR 901 router uses only console port.



Note Console and rollover cables are not included with the Cisco ASR 901 router. You can order the console cable from Cisco Systems, Inc. (Part number ACS-1900ASYN=).

Console Port Connections

The router provides an EIA/TIA-232 asynchronous serial console port (RJ-45). Depending on the cable and the adapter used, this port appears as a data terminal equipment (DTE) or data communications equipment (DCE) device at the end of the cable.

To connect an ASCII terminal to the console port, use the RJ-45 rollover cable with the female RJ-45-to-DB-25 adapter (labeled TERMINAL). To connect a PC running terminal emulation software to the console port, use the RJ-45 rollover cable with the female RJ-45-to-DB-9 adapter (labeled TERMINAL). The default parameters for the port are 9600 baud, 8 data bits, no parity, and 2 stop bits. As a console port, hardware flow control is not supported. For instructions on installing a console terminal, see the [Connecting the Console Port, on page 19](#).

For cable and port pinouts, see the *Cisco Modular Access Router Cable Specifications* document. This document is provided on the documentation DVD that accompanied your router (if ordered), and is also available online at Cisco.com.

Network Modules

You can order the Cisco ASR 901 router as a satellite shelf with the following interface modules.

- SFP Ethernet interface module
- RJ-45 Ethernet interface module

Interface modules are installed and shipped with the router; they are not field replaceable.

Mounting the Cisco ASR 901 Router

Each Cisco ASR 901 router includes rack-mounting brackets. Using the rack-mounting brackets, you can front-mount the Cisco ASR 901 router in a 19-inch (48.3-cm) equipment rack that conforms to the EIA-310-D specification (the inside width of the rack should be 17.72 to 17.80 inches [45 to 45.21 cm]).

Using the two rack-mounting brackets for mounting (part number 700-33522-01), you can recess Cisco ASR 901 router in the equipment rack. This arrangement provides extra space in front of the router for the cables and allows you to close the doors of racks equipped with front-close doors.

If you need to attach or replace the rack-mounting brackets, see the [Attaching the Rack-Mounting Brackets, on page 10](#).

The rack-mounting brackets are slotted to allow the router to be mounted in racks with EIA 1.25-inch (3.175-cm) or WECCO 1.0-inch (2.54-cm) hole spacing. When installed in the rack, the Cisco ASR 901 router requires one EIA 1.75-inch (4.4-cm) vertical mounting space (or 1 rack unit [RU]) for mounting (see the [Mounting the Cisco ASR 901 Router in a Rack, on page 11](#)).

**Caution**

Allow clearance on either side of the Cisco ASR 901 router for cooling air to be drawn in through the left side and circulated through the chassis and out the two fan exhaust ports mounted on the other side of the chassis.

Rack-Mounting Configuration Guidelines

Follow these guidelines to configure the equipment rack:

- When mounting the router to an equipment rack, ensure that the rack is bolted to the floor.
- Because you may install more than one router into the rack, ensure that the weight of all of the routers installed does not make the rack unstable.

**Caution**

Some equipment racks are also secured to ceiling brackets, if necessary, due to the weight of the equipment in the rack. Make sure that the rack that you are using to install the routers is secured to the building structure.

- As mentioned in the [Airflow Guidelines, on page 5](#), maintain a 6-inch (15.24-cm) clearance on each side of the router to ensure adequate air intake and exhaust.
- Avoid installing the routers in an overly congested rack. Air flowing to or from other routers in the rack might interfere with the normal flow of cooling air through the routers, increasing the potential for overtemperature conditions within the routers.
- Allow at least 19 inches (48.7 cm) of clearance at the front and rear of the rack for router maintenance.
- Follow your local practices for cable management. Ensure that cables to and from the routers do not impede access to perform equipment maintenance or upgrades.

Attaching the Rack-Mounting Brackets

Complete the following tasks to install, replace, or rearrange the rack-mounting brackets so you can then mount the Cisco ASR 901 router in a 19-inch (48.3-cm) equipment rack. You can use the same rack-mounting brackets to front-mount the Cisco ASR 901 router in the equipment rack.

SUMMARY STEPS

1. Locate the mounting holes of the Cisco ASR 901 router.
2. Align the rack-mounting bracket with the Cisco ASR 901 router and position with the four #6-32 x 0.25-inch screws (provided) (see this figure for front-mounting).
3. Insert the screws (four places) and tighten using a Number 2 Phillips screwdriver.
4. Repeat Steps 2 and 3 for the other rack-mounting bracket.

DETAILED STEPS

-
- Step 1** Locate the mounting holes of the Cisco ASR 901 router.
- Step 2** Align the rack-mounting bracket with the Cisco ASR 901 router and position with the four #6-32 x 0.25-inch screws (provided) (see this figure for front-mounting).

Figure 1: Attaching the Bracket for Front-Mounting

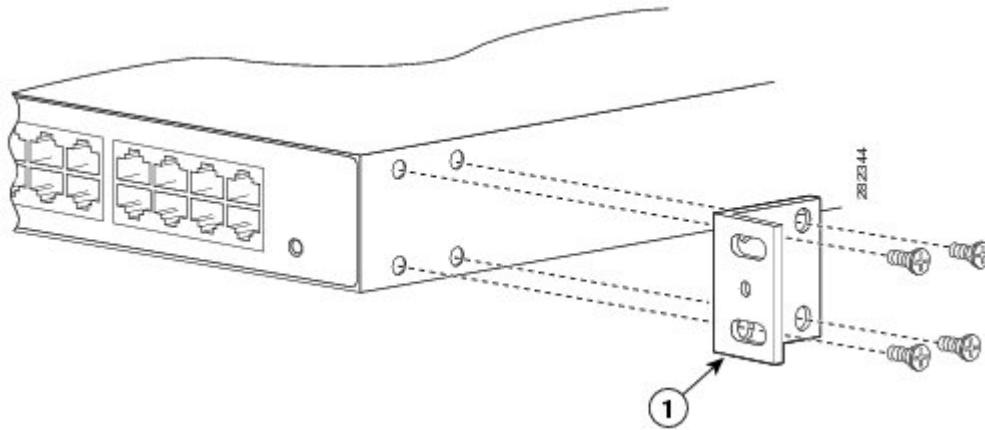

1	Rack mount bracket
---	--------------------

Step 3 Insert the screws (four places) and tighten using a Number 2 Phillips screwdriver.

Step 4 Repeat Steps 2 and 3 for the other rack-mounting bracket.

Proceed to the next section, “[Mounting the Cisco ASR 901 Router in a Rack, on page 11](#)”, to continue the installation.

Mounting the Cisco ASR 901 Router in a Rack

Typically, the Cisco ASR 901 router mounts to a 19-inch (48.3-cm) 2-post equipment rack with rack-mounting brackets that attach toward the front of the router sides. The inside width between the two posts or mounting strips (left and right) must be at least 17.72 to 17.80 inches (45 to 45.21 cm). For more information about the equipment rack, see the “[Cisco ASR 901 Router Hardware Description](#)” section .

No vertical clearance is necessary above or below the router when it is mounted in the rack.

To secure the Cisco ASR 901 router to the equipment rack, you must use the two mounting screws (provided) for each side or follow your local practices for installing the router into your equipment rack. Ensure that the rack-mount brackets are securely fastened. For more information, see the [Attaching the Rack-Mounting Brackets, on page 10](#).

To mount the Cisco ASR 901 router into the equipment rack, perform the following procedure.



Caution

To prevent injury, review the [Safety Guidelines, on page 1](#) and the [Rack-Mounting Configuration Guidelines, on page 10](#) before installing the Cisco ASR 901 router in the equipment rack.

SUMMARY STEPS

1. Locate the equipment rack position where you plan to install the router.
2. Verify that there are no obstructions and ensure that the equipment rack is stabilized.

3. Position the router in the equipment rack lining up the bracket holes on the router with the holes on the rack and secure with four #6-32 x 0.25-inch mounting screws (two on each side).
4. Tighten the screws using a 1/4-inch flat-blade screwdriver (each side).

DETAILED STEPS

-
- Step 1** Locate the equipment rack position where you plan to install the router.
- Step 2** Verify that there are no obstructions and ensure that the equipment rack is stabilized.
- Step 3** Position the router in the equipment rack lining up the bracket holes on the router with the holes on the rack and secure with four #6-32 x 0.25-inch mounting screws (two on each side).
- Note** The vertical spacing for EIA equipment racks is 1.75 inches (4.44 cm), with mounting holes spaced 1.5 inches (3.81 cm) apart.
- Step 4** Tighten the screws using a 1/4-inch flat-blade screwdriver (each side).
-

Attaching the Cable Guides

Complete the following steps to attach the two cable guides to the front of the mounting brackets. This procedure is optional.



-
- Note** The cable guides are useful only if your router is front-mounted. Do not attach the cable guides if your router is center-mounted or recess-mounted.
-

Use the cable guides to dress the cables that attach to the front of the Cisco ASR 901 router. The cable guides allow you to gather the cables and direct them to the left and right sides of the router. This helps to keep the cables from obscuring the fronts of lower routers in the same rack.

SUMMARY STEPS

1. In the accessory kit, locate the two cable guides (part number 700-01663-01) and two M4.0x20mm Phillips screws used to attach the cable guides (part number 48-0654-01).
2. Position the cable guide over the threaded hole in the front flange of either the left or right mounting bracket. The threaded hole is located midway between the two slotted holes used to mount the unit to the rack.
3. Use an M4.0x20mm Phillips screw to fix the cable guide to the mounting bracket. Do not over-tighten the screw.
4. Repeat Steps 2 and 3 to attach the other cable guide.

DETAILED STEPS

-
- Step 1** In the accessory kit, locate the two cable guides (part number 700-01663-01) and two M4.0x20mm Phillips screws used to attach the cable guides (part number 48-0654-01).

- Step 2** Position the cable guide over the threaded hole in the front flange of either the left or right mounting bracket. The threaded hole is located midway between the two slotted holes used to mount the unit to the rack.

Figure 2: Attaching the Cable Guide

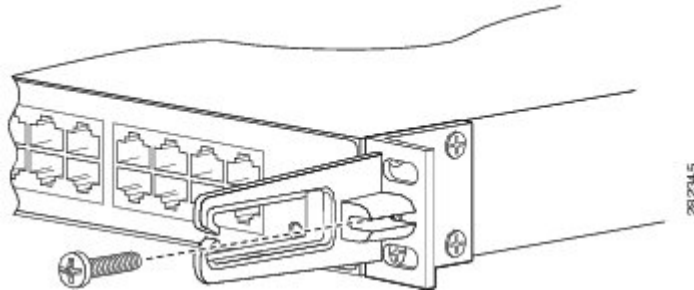

- Step 3** Use an M4.0x20mm Phillips screw to fix the cable guide to the mounting bracket. Do not over-tighten the screw.

- Step 4** Repeat Steps 2 and 3 to attach the other cable guide.

Note If you find it awkward to insert the screw while holding the cable guide in place, you can first insert the screw only far enough so that it does not fall out. Then, using the slot in the mounting pillar of the cable guide, slide the cable guide into place around the screw. Finally, tighten the screw to fix the cable guide to the mounting bracket.

Connecting the Chassis Ground and Power

Before you connect power or turn on power to the Cisco ASR 901 router, you must provide an adequate chassis ground (earth) connection to your router.

Grounding the Cisco ASR 901 Router

The Cisco ASR 901 router provides a grounding point on the rear of the unit for a 2-hole lug.

To ensure the chassis ground connection that you provide is adequate, you need the following parts and tools:

- Ratcheting torque screwdriver with Phillips head that exerts up to 15 pound-force inches (lbf-in) of pressure for attaching the ground wire to the router.
- Crimping tool as specified by the ground lug manufacturer
- 16-AWG copper wire for the power cord
- Wire-stripping tools appropriate to the wire you are using



Warning Before making connections to the Cisco ASR 901 router, ensure that you disconnect the power at the circuit breaker. Otherwise it may result in severe injury or damage to the router.



Warning This equipment must be grounded. Never defeat the ground conductor or operate the equipment in the absence of a suitably installed ground conductor. Contact the appropriate electrical inspection authority or an electrician if you are uncertain that suitable grounding is available. Statement 1024



Warning Use copper conductors only. Statement 1025



Warning When installing or replacing the unit, the ground connection must always be made first and disconnected last. Statement 1046

This figure shows the grounding point marked on the rear panel of the Cisco ASR 901 router for ease of installation

Figure 3: Grounding Point

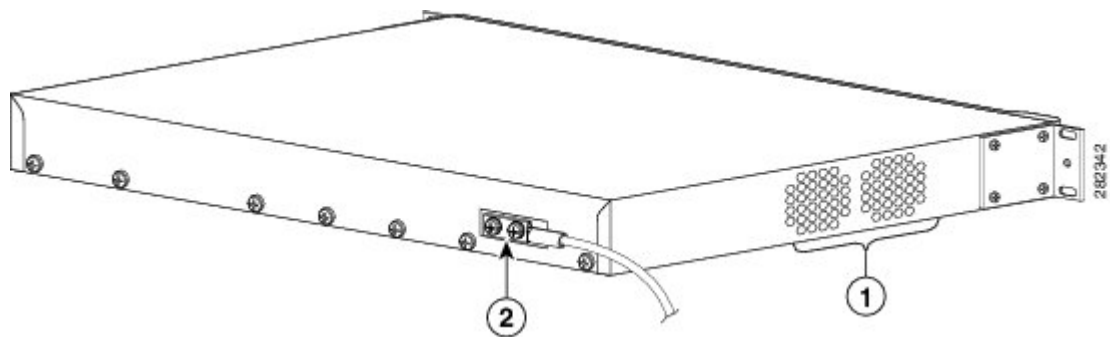

1	Fan
2	Grounding point lug

This unit is to be installed in a restrictive access location and must be permanently grounded to minimum 6-AWG copper ground wire.

Complete the following steps to ground the Cisco ASR 901 router using a 2-hole lug and the corresponding mounting point. Most carriers require a 6-AWG ground connection. Verify your carrier's requirements for the ground connection.

-
- Step 1** In the accessory kit, locate the 2-hole lug, 2 pan-head Phillips head screws used to attach the lug to the router, and 6-AWG ground wire. (Lug, screws, and wire are part number 32-0629-01.)
- Step 2** Set the parts aside.
- Step 3** If your ground wire is insulated, use a wire-stripping tool to strip the ground wire to 0.5 inch \pm 0.02 inch (12.7 mm \pm 0.5 mm) for the ring terminal.

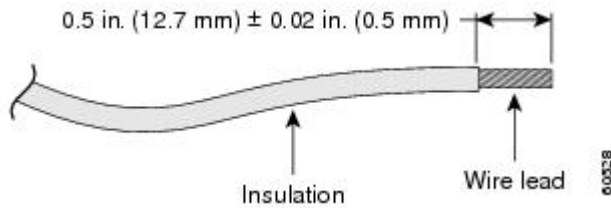
Figure 4: Stripping a Ground Wire

- Step 4** Slide the open end of your ground lug over the exposed area of the ground wire.
- Step 5** Using a crimping tool (as specified by the ground lug manufacturer), crimp the ground lug to the ground wire (as shown in this figure).

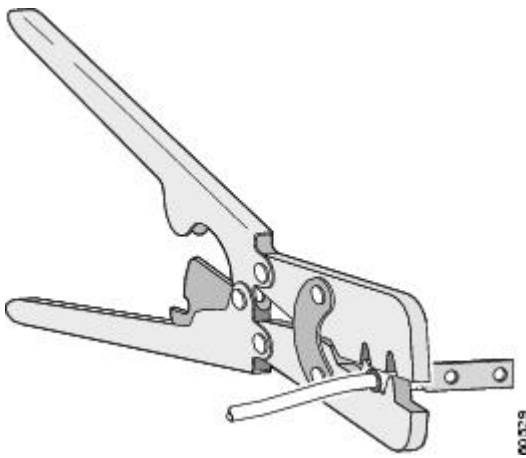
Figure 5: Crimping a Ground Lug onto the Ground Wire

- Step 6** Use a Phillips head screwdriver to attach the ground lug and wire assembly to the front of the router with the 2 screws from the accessory kit.
- Step 7** Connect the other end of the ground wire to a suitable grounding point at your site.

Power Connection Compliance



Warning Before performing any of the following procedures, ensure that power is removed from the DC circuit. Statement 1003



Warning Use copper conductors only. Statement 1025



Note The installation must comply with the 2002 National Electric Code (NEC) and other applicable codes.

Wiring the DC Input Power Source



Warning This product relies on the building's installation for short-circuit (overcurrent) protection. Ensure that the protective device is rated not greater than 10 A minimum, 60 VDC. Statement 1005

Complete the following steps to connect the DC power supply to the Cisco ASR 901 router:

SUMMARY STEPS

1. Switch off the DC power source at the circuit breaker, and place the circuit breaker in the Off position.
2. Locate the 6-pin terminal block (part number 27-2030-01). The terminal block is located in the accessory kit (part number 53-3085-01 for the Cisco ASR 901 router), which is shipped with the router.
3. Plug the 6-pin terminal block into the power connector located on the front side of the router.
4. Connect one end of the customer-supplied power cord (16-AWG copper wire) to the site DC power source.
5. Plug the connector on the power supply cord into the 6-pin terminal block that you plugged into the rear of the router in Step 3.

DETAILED STEPS

Step 1 Switch off the DC power source at the circuit breaker, and place the circuit breaker in the Off position.

Step 2 Locate the 6-pin terminal block (part number 27-2030-01). The terminal block is located in the accessory kit (part number 53-3085-01 for the Cisco ASR 901 router), which is shipped with the router.

Figure 6: 6-Pin Terminal Block

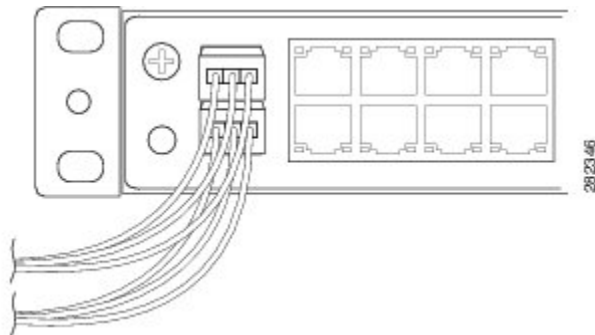

Step 3 Plug the 6-pin terminal block into the power connector located on the front side of the router.

Step 4 Connect one end of the customer-supplied power cord (16-AWG copper wire) to the site DC power source.

Step 5 Plug the connector on the power supply cord into the 6-pin terminal block that you plugged into the rear of the router in Step 3.

What to do next**Warning**

An exposed wire lead from a DC-input power source can conduct harmful levels of electricity. Be sure that no exposed portion of the DC-input power source wire extends from the connector(s) or terminal block(s). Statement 122

**Warning**

Secure all power cabling when installing this unit to avoid disturbing field-wiring connections. Statement 38

**Caution**

Do not power on the unit yet.

Installing and Removing SFP Modules

This section describes how to install and remove SFP modules. The modules are inserted into the SFP module slots on the front of the Cisco ASR 901 router. These field-replaceable modules provide interfaces.

See the *Release Notes for Cisco ASR 901 Series Aggregation Services Router* for the list of supported SFP modules. Each port must match the wavelength specifications on the other end of the cable. For reliable communications, the cable must not exceed 328 feet (100 meters).

For detailed instructions on installing, removing, and cabling the SFP module, see the SFP module documentation.

Installing SFP Modules

This figure shows an SFP module that has a bale-clasp latch.

**Caution**

We strongly recommend that you do not install or remove fiber-optic SFP modules with cables attached because of the potential damage to the cables, the cable connector, or the optical interfaces in the SFP module. Disconnect all cables before removing or installing an SFP module. Removing and installing an SFP module can shorten its useful life. Do not remove and insert SFP modules more often than is absolutely necessary.

Figure 7: SFP Module with a Bale-Clasp Latch

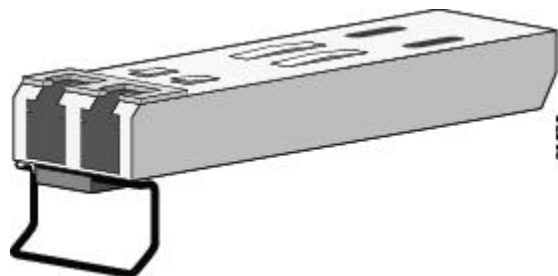

Complete the following steps to insert an SFP module into the module slot:

SUMMARY STEPS

1. Attach an ESD-preventive wrist strap to your wrist and to a bare metal surface on the chassis.
2. If the SFP module that you are using has the markings, use them to identify the top side of the module.
3. Align the SFP module in front of the slot opening.
4. Insert the SFP module into the slot until you feel the connector on the module snap into place in the rear of the slot (see the figure below).
5. For fiber-optic SFP modules, remove the dust plugs from the optical ports, and store them for later use.
6. Insert the cable connector into the SFP module:

DETAILED STEPS

Step 1 Attach an ESD-preventive wrist strap to your wrist and to a bare metal surface on the chassis.

Some SFP modules identify the top side of the module with transmit (TX) and receive (RX) markings or arrows that show the direction of the connection.

Step 2 If the SFP module that you are using has the markings, use them to identify the top side of the module.

Step 3 Align the SFP module in front of the slot opening.

Step 4 Insert the SFP module into the slot until you feel the connector on the module snap into place in the rear of the slot (see the figure below).

Figure 8: Installing an SFP Module into an SFP Module Slot

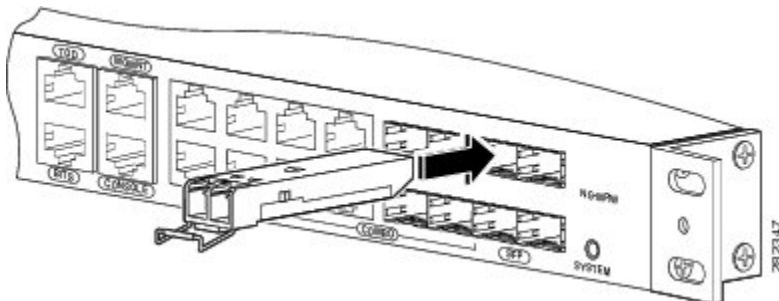

Step 5 For fiber-optic SFP modules, remove the dust plugs from the optical ports, and store them for later use.

Caution Do not remove the dust plugs from the fiber-optic SFP module port or the rubber caps from the fiber-optic cable until you are ready to connect the cable. The plugs and caps protect the SFP module ports and cables from contamination and ambient light.

Step 6 Insert the cable connector into the SFP module:

- For fiber-optic SFP modules, insert the line card or MT-RJ cable connector into the SFP module.
- For copper 1000BASE-T SFP modules, insert the RJ-45 cable connector into the SFP module.

Removing SFP Modules

Complete the following steps to remove an SFP module from a module receptacle:

Step 1 Attach an ESD-preventive wrist strap to your wrist and to a bare metal surface on the chassis.

Step 2 Disconnect the cable from the SFP module, and insert a dust plug into the cable end.

Tip For reattachment, note which cable connector plug is transmit (TX) and which is receive (RX).

Step 3 Unlock and remove the SFP module, as shown in this figure.

If the module has a bale-clasp latch, pull the bale out and down to eject the module. If the bale-clasp latch is obstructed and you cannot use your index finger to open it, use a small, flat-blade screwdriver or other long, narrow instrument to open the bale-clasp latch.

Figure 9: Removing a Bale-Clasp Latch SFP Module by Using a Flat-Blade Screwdriver

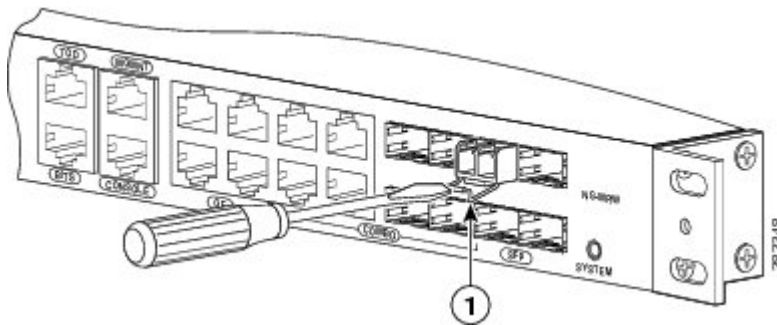

1	Bale clasp
---	------------

Step 4 Grasp the SFP module between your thumb and index finger, and carefully remove it from the module slot.

Step 5 For fiber-optic SFP modules, insert a dust plug into the optical ports of the SFP module to keep the optical interfaces clean.

Step 6 Place the removed SFP module in an antistatic bag or other protective environment.

Connecting Cables

This section describes how to connect the Cisco ASR 901 router to external devices and networks. It includes the following sections:

Connecting the Console Port



Warning

Avoid using or servicing any equipment that has outdoor connections during an electrical storm. There may be a risk of electric shock from lightning. Statement 1088

The Cisco ASR 901 router has a single console port that can function in DTE mode:

- DTE-mode console (terminal) port for connecting a console terminal



Note The console port functions are asynchronous serial ports; any devices connected to the console port must be cabled for asynchronous transmission. (Asynchronous is the most common type of serial device; for example, most modems are asynchronous devices.)

The Cisco ASR 901 router uses RJ-45 ports for console port function.

We provide the following cables and adapters for connecting the Cisco ASR 901 router to a console terminal:

- One console adapter cable (RJ-45-to-DB-9, blue)

Types of RJ-45 Cables

Cisco products use the following three types of RJ-45 cables:

- Straight-through
- Crossover
- Rolled (or Rollover)

The Cisco ASR 901 router ships with and uses the rollover cable. For instructions on how to identify a rollover cable, see [Identifying a Rollover Cable, on page 23](#).

Console Port

Complete the following steps to connect a terminal or a PC running terminal emulation software to the console port on the router:

SUMMARY STEPS

1. Connect the terminal using an RJ-45 rollover cable and an RJ-45-to-DB-25 or RJ-45-to-DB-9 adapter (labeled TERMINAL) to the console port. For cable pinouts, see the [“Console Port Signals and Pinouts” section](#).
2. Configure the terminal or terminal emulation software for 9600 baud, 8 data bits, no parity, and 2 stop bits.

DETAILED STEPS

Step 1 Connect the terminal using an RJ-45 rollover cable and an RJ-45-to-DB-25 or RJ-45-to-DB-9 adapter (labeled TERMINAL) to the console port. For cable pinouts, see the [“Console Port Signals and Pinouts” section](#).

Note The RJ-45-to-DB-25 adapter (Cisco part number 29-0810-01) can be purchased from Cisco Systems.

Step 2 Configure the terminal or terminal emulation software for 9600 baud, 8 data bits, no parity, and 2 stop bits.

Note Hardware flow control is not possible on the console port.

Connecting the Network Cables

This section describes how to connect the following router interfaces:

Connecting Gigabit Ethernet Interface Cables

The RJ-45 port supports standard straight-through and crossover Category 5 unshielded twisted-pair (UTP) cables. Cisco Systems does not supply Category 5 UTP cables; these cables are available commercially.

Complete the following steps to connect the cable to the router Gigabit Ethernet port:

SUMMARY STEPS

1. Confirm that the router is powered off.
2. Connect one end of the cable to the GE port on the router.
3. Connect the other end to the BTS patch or demarcation panel at your site.

DETAILED STEPS

-
- | | |
|---------------|---|
| Step 1 | Confirm that the router is powered off. |
| Step 2 | Connect one end of the cable to the GE port on the router. |
| Step 3 | Connect the other end to the BTS patch or demarcation panel at your site. |
-

What to do next

For more information about Gigabit Ethernet connectors including pinouts, see the [“Gigabit Ethernet Connector Pinouts”](#) section.

Connecting SFP Cables

Complete these steps to connect the cable to a router SFP port.

SUMMARY STEPS

1. Confirm that the router is powered off.
2. Insert the SFP module patch cable into the slot until you feel the connector on the cable snap into place in the rear of the slot.
3. Connect the other end to the patch or demarcation panel at your site.
4. Turn on power to the router (see the [Powering On the Router, on page 24](#) for more details).

DETAILED STEPS

-
- | | |
|---------------|--|
| Step 1 | Confirm that the router is powered off. |
| Step 2 | Insert the SFP module patch cable into the slot until you feel the connector on the cable snap into place in the rear of the slot. |
| Step 3 | Connect the other end to the patch or demarcation panel at your site. |
| Step 4 | Turn on power to the router (see the Powering On the Router, on page 24 for more details). |
-

What to do next

For more information about SFP connectors, see the [SFP Port Pinouts and Cable Specifications](#).

Connecting Cables to the BITS Interface

Complete these steps to connect the cable to the router BITS port:

SUMMARY STEPS

1. Confirm that the router is powered off.
2. Connect one end of the cable to the BITS port using a T1/E1 cable.
3. Connect the other end to the SETS unit.
4. Turn on power to the router (see the [Powering On the Router, on page 24](#) for more details).

DETAILED STEPS

-
- | | |
|---------------|--|
| Step 1 | Confirm that the router is powered off. |
| Step 2 | Connect one end of the cable to the BITS port using a T1/E1 cable. |
| Step 3 | Connect the other end to the SETS unit. |
| Step 4 | Turn on power to the router (see the Powering On the Router, on page 24 for more details). |
-

What to do next

For more information about T1/E1 connectors including pinouts, see the [T1/E1 Port Pinouts](#).

Connecting GPS Cables

The following sections describe how to connect cables from the Cisco ASR 901 router to a GPS unit for input or output timing or frequency.

- [Connecting Cables to the 10-Mhz or 1-PPS Interface, on page 22](#)
- [Connecting Cables to the ToD Interface, on page 23](#)

Connecting Cables to the 10-Mhz or 1-PPS Interface

Complete these steps to connect cables to the 10-Mhz or 1-PPS interface:

SUMMARY STEPS

1. Confirm that the router is powered off.
2. Connect one end of a mini-coax cable to the GPS unit.
3. Connect the other end of the mini-coax cable to the 10-Mhz or 1-PPS port on the Cisco ASR 901 router.

DETAILED STEPS

-
- | | |
|---------------|---|
| Step 1 | Confirm that the router is powered off. |
| Step 2 | Connect one end of a mini-coax cable to the GPS unit. |

- Step 3** Connect the other end of the mini-coax cable to the 10-Mhz or 1-PPS port on the Cisco ASR 901 router.
- For instructions on how to configure clocking, see the *Cisco ASR 901 Series Aggregation Services Router Software Configuration Guide*.
-

What to do next

For more information about 10-Mhz and 1-PPS port pinouts, see the [GPS Port Pinouts](#).

Connecting Cables to the ToD Interface

Complete these steps to connect cables to the ToD interface for GPS timing.

SUMMARY STEPS

1. Confirm that the router is powered off.
2. Connect one end of a straight-through Ethernet cable to the GPS unit.
3. Connect the other end of the cable to the ToD port on the Cisco ASR 901 router.

DETAILED STEPS

- Step 1** Confirm that the router is powered off.
- Step 2** Connect one end of a straight-through Ethernet cable to the GPS unit.
- Step 3** Connect the other end of the cable to the ToD port on the Cisco ASR 901 router.
- For instructions on how to configure clocking, see the *Cisco ASR 901 Router Software Configuration Guide*.
- Note** For more information about BITS port pinouts, see the [Time of Day Pinouts](#).
-

Connecting to the Alarm Port

Use a straight cable to connect to the alarm port. For details on the pinouts, see the [Alarm Port Pinouts](#) section.

Connecting to the Management Ethernet Port

Use a straight or a crossover Ethernet cable to connect to the management ethernet port. For details on the pinouts, see the [Management Ethernet Port Pinouts](#) section.

Identifying a Rollover Cable

To identify a rollover cable, compare the modular plugs at the two ends of the cable. When you hold the plugs side by side, with the tab at the back, the wire connected to the pin on the outside of the left plug should be the same color as the wire connected to the pin on the outside of the right plug (see figure below.) If you purchased your cable from Cisco Systems, pin 1 is white on one connector, and pin 8 is white on the other (a rollover cable connects pins 1 and 8, 2 and 7, 3 and 6, and 4 and 5).

Figure 10: Identifying a Rollover Cable

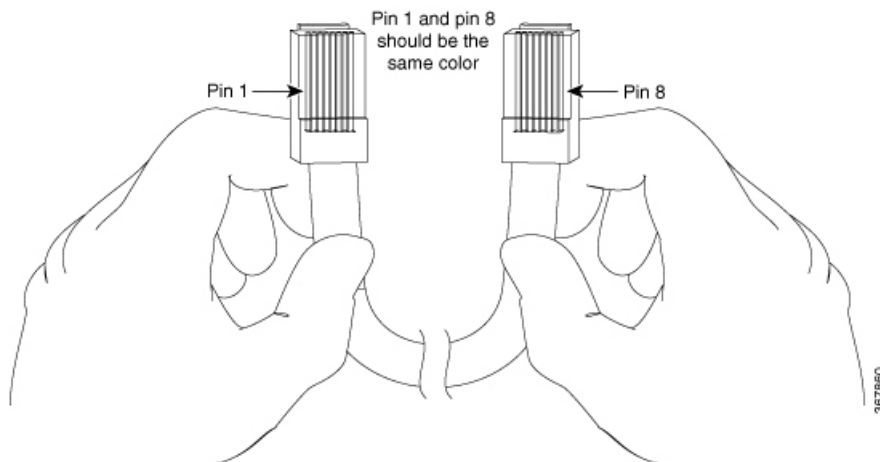

Dressing Router Cables

Ensure that all Cisco router cables are properly dressed so as not to interfere with each other or other pieces of equipment. Use local practices to ensure that the cables attached to your router are properly dressed.



Note If your Cisco ASR 901 router is front-mounted, you can use the cable guide (found in the accessory kit) to dress the cables.

To continue the installation, proceed to the next section, [“Powering On the Router, on page 24.”](#)

Powering On the Router



Warning Do not touch the power supply when the power cord is connected. For systems with a power switch, line voltages are present within the power supply even when the power switch is off and the power cord is connected. For systems without a power switch, line voltages are present within the power supply when the power cord is connected. Statement 4



Warning This equipment must be grounded. Never defeat the ground conductor or operate the equipment in the absence of a suitably installed ground conductor. Contact the appropriate electrical inspection authority or an electrician if you are uncertain that suitable grounding is available. Statement 1024

Checklist for Power Up

Complete these steps to power on the Cisco ASR 901 router:

- Securely mount the router.
- Properly connect the power, network, and interface cables.

Interpreting Front-Panel LEDs

The Cisco ASR 901 router provides a number of LEDs on the front panel to monitor conditions and to aid in troubleshooting problems. For a description of the LEDs, see the [LEDs](#) section.

Power-On Procedure

Complete these steps to power on the Cisco ASR 901 router and verify its initialization and self-test:

SUMMARY STEPS

1. Remove the tape from the circuit breaker switch handle.
2. Restore power by moving the handle of the circuit breaker to the ON position.

DETAILED STEPS

Step 1 Remove the tape from the circuit breaker switch handle.

Step 2 Restore power by moving the handle of the circuit breaker to the ON position.

The LED (labeled POWER) on the front panel should go ON, and the fans should operate.

Depending on your installation, other front-panel LEDs can also come on.

Note If you encounter problems when you power on the router, see the “Troubleshooting” section in the *Cisco ASR 901 Series Aggregation Services Router Hardware Installation Guide*.

What to Do After Installing the Hardware

After you install the router hardware, see the *Cisco ASR 901 Series Aggregation Services Router Software Configuration Guide* for the software configuration information.

