



Installing the Router

This section contains the following:

- [Overview, on page 1](#)
- [Equipment, Tools, and Connections, on page 2](#)
- [Items Shipped with your Router, on page 2](#)
- [Additional Items Needed, on page 3](#)
- [Ethernet Devices, on page 3](#)
- [Installing the Router, on page 3](#)
- [Grounding Warning, on page 4](#)
- [Mounting on a Wall, Table, or Other Flat Surface, on page 4](#)
- [Installing a Pluggable Module, on page 7](#)
- [Installing the Router Ground Connection, on page 11](#)
- [Installing a DIN Rail, on page 13](#)

Overview

This chapter describes the equipment and the procedures for successfully installing the Cisco IR1101 Base Router. There is a separate section for installing the IR1101 with an Expansion Module.



Caution

Do not install the router or power supplies next to a heat source of any kind, including heating vents.



Caution

Online Insertion and Removal (OIR) is not supported on the IR1101 or any of its modules. If a module is inserted or pulled out while the device is powered up, it may damage the device.



Warning

Read the installation instructions before connecting the system to the power source. **Statement 1004**



Warning

Only trained and qualified personnel should be allowed to install, replace, or service this equipment. **Statement 1030**



Warning Ultimate disposal of this product should be handled according to all national laws and regulations. **Statement 1040**



Warning Do not locate the antenna near overhead power lines or other electric light or power circuits, or where it can come into contact with such circuits. When installing the antenna, take extreme care not to come into contact with such circuits, because they may cause serious injury or death. For proper installation and grounding of the antenna, please refer to national and local codes (for example, U.S.:NFPA 70, National Electrical Code, Article 810, Canada: Canadian Electrical Code, Section 54). **Statement 1052**



Warning No user-serviceable parts inside. Do not open. **Statement 1073**



Warning This product is not intended to be directly connected to the Cable Distribution System. Additional regulatory compliance and legal requirements may apply for direct connection to the Cable Distribution System. This product may connect to the Cable Distribution System **ONLY** through a device that is approved for direct connection. **Statement 1078**



Warning A minimum of 1 inch clearance is required on all sides of the device except for the side mounted against the wall/floor or DIN rail. Stacking heat-dissipating objects on top of the router is not allowed. I/O side clearance is needed as it is required to access the cable connections. Clearance is required to attach, mount the DIN rail bracket, and Wall mount bracket.

Equipment, Tools, and Connections

This section describes the equipment, tools, and connections necessary for installing your Cisco IR1101.



Note There are no antennas shipped with the IR1101. They must be ordered separately.

Items Shipped with your Router

Unpack the box and verify that all items listed on the invoice were shipped with the Cisco IR1101.

The following items are shipped with your router:

- Getting Started/Product Document of Compliance
- Grounding Lug Kit

- Power Connector

Additional Items Needed

The following items are not shipped with the router but are required for installation:

- ESD-preventive cord and wrist strap.
- Wire crimper for chassis grounding.
- Wire for connecting the chassis to an earth ground.
- Ethernet cables for connecting to the Fast Ethernet (FE) WAN and LAN ports
- A flathead 2mm screwdriver
- A flathead 3.5mm screwdriver
- A number 1 Phillips screwdriver
- A number 2 Phillips screwdriver



Note Use the #2 Phillips screwdriver for all screw installations unless specified otherwise.

Ethernet Devices

Identify the Ethernet devices that you will connect to the router. Ensure that each device has a network interface card (NIC) for connecting to Ethernet ports.

Installing the Router

This section describes how to install the Cisco IR1101. This router can be installed in the following ways:

- Table top
- Flat horizontal surface
- Mounted on a wall
- Using a DIN rail

Grounding Warning



Warning For NEC-compliant grounding, use size 16awg (1.5mm²) or larger copper wire and a ring terminal with an inner diameter of 1/4 in. (6 to 7mm).

Mounting on a Wall, Table, or Other Flat Surface

The Cisco IR1101 can be mounted in a vertical or horizontal orientation. It can be mounted to a wall or other flat surface, and can also be mounted to a DIN rail.



Note See the [Overview, on page 1](#) section for limitations on mounting with an expansion module attached.



Tip When choosing a location for wall-mounting a router, consider cable limitations and wall structure, and consider suitable antenna location ahead of time.



Warning Read the wall-mounting instructions carefully before beginning installation. Failure to use the correct hardware or to follow the correct procedures could result in a hazardous situation to people and damage to the system. **Statement 378**



Warning A minimum of 1 inch clearance is required on all sides of the device except for the side mounted against the wall/floor or DIN rail, to allow for proper air flow.

The wall mounting kit contains the following:

- Mounting brackets (x2)
- Mounting screws (x4) M4 x 6mm

To mount the router on a wall or other flat surface, follow these steps:

Step 1 Attach the mounting brackets to the bottom of the router. Refer to the following for guidance.

Figure 1: Cisco IR1101 Mounting Bracket

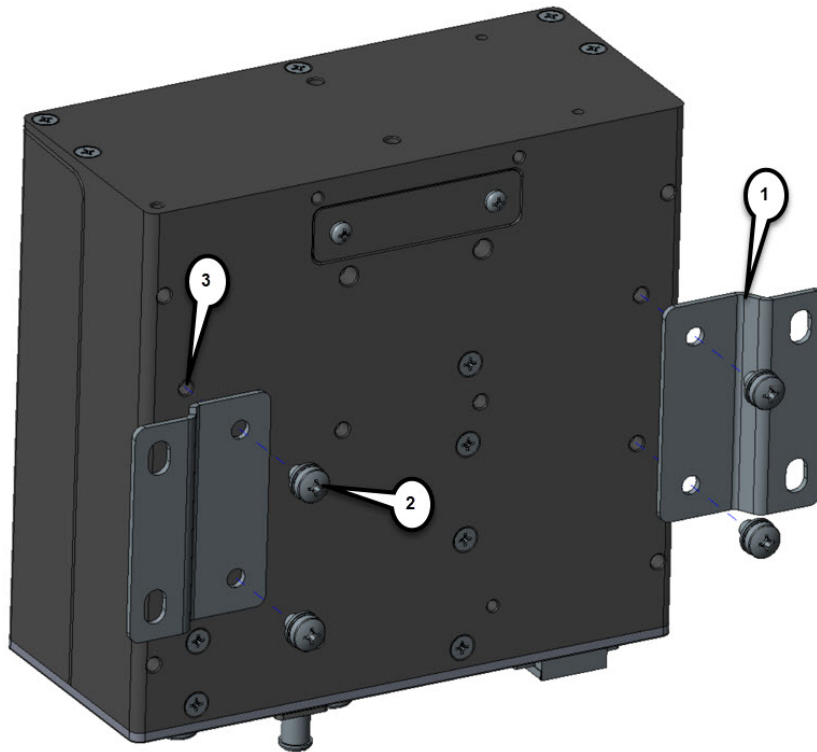

- Step 2** Align the mounting brackets (1) over the mounting holes (3) so that the larger holes on the brackets extend out over the router.
- Step 3** Attach the brackets to the router with the four screws (2) provided using a Phillips head driver. Torque to 13-15 in. lbs.
- Step 4** Mount the router with the attached brackets in a proper wall structure to carry the weight of the device. See the following for the dimensions of the mounting holes with the brackets attached to the router

Figure 2: Wall/Floor mounting hole dimensions with mounting brackets attached

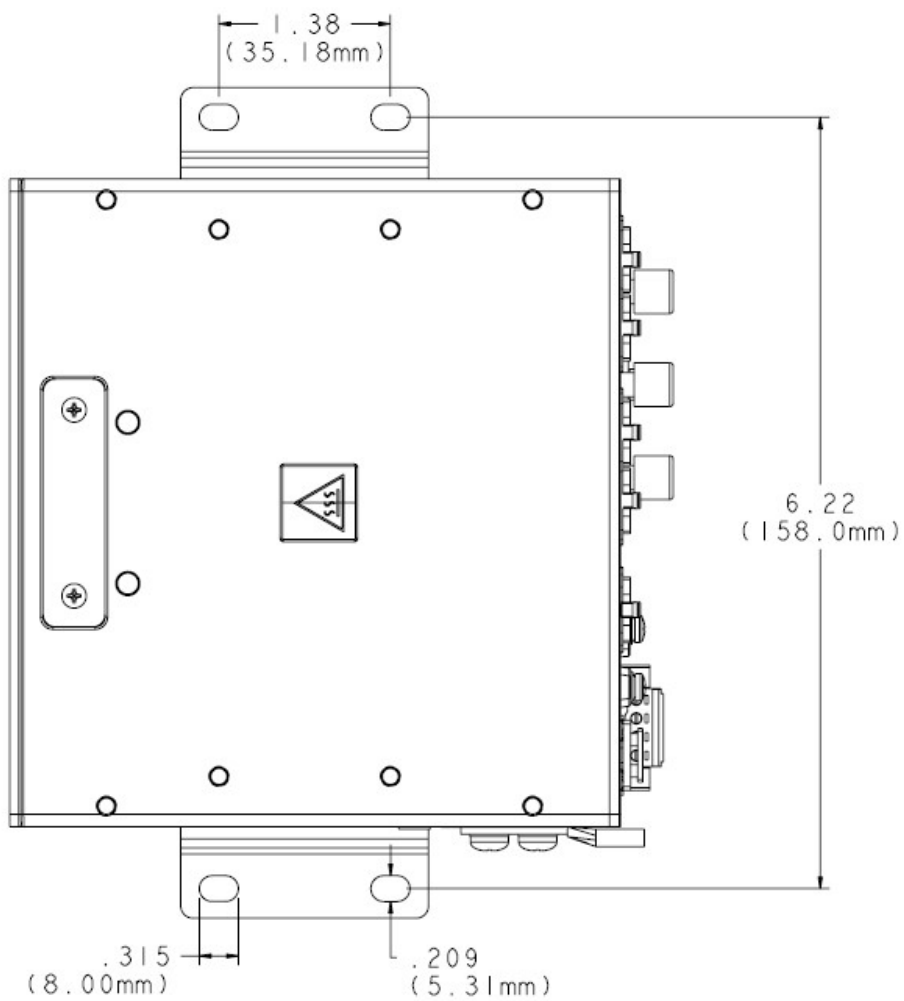

Note Four #10-32 screws are recommended when mounting the unit with these brackets attached to the neighboring surface.

Figure 3: Wall/Floor mounting clearance and overall dimensions with mounting brackets attached

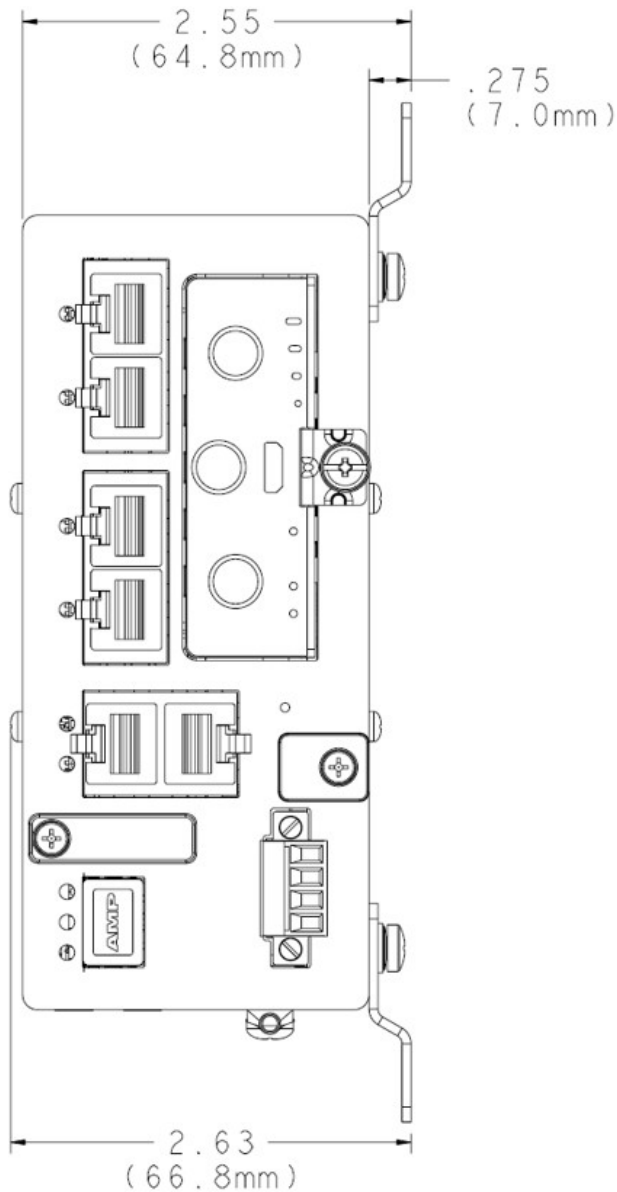

Step 5 Route the cables so that they do not put a strain on the connectors or mounting hardware.

Installing a Pluggable Module

The Pluggable Module provides the IR1101 with a number of different configuration options. In this section the modular cellular modem Pluggable Module remove and replace option is shown.

The IR1101 may have a blank plate covering the Pluggable Module slot. This will need to be removed prior to installing the cellular modem module. The following example shows the LTE Pluggable Module.

Step 1 Remove the blank plate by unscrewing the latch lock screw(1) that holds the plate secure. Refer to the following figure.

Figure 4: Latch Lock Screw

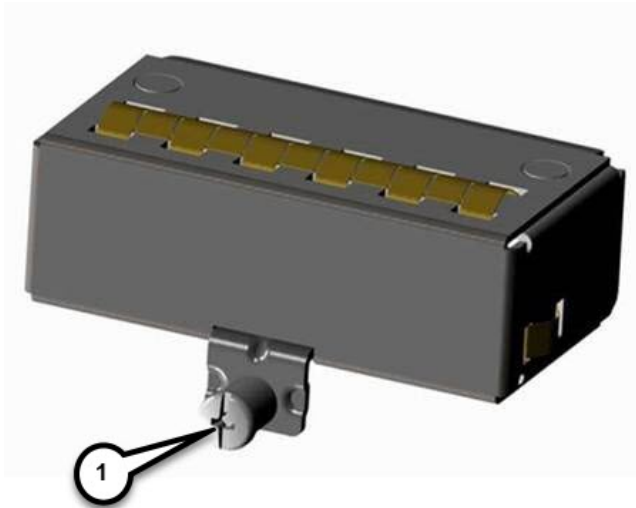

Step 2 Slide the blank plate out of the device.

Step 3 Prepare the cellular modem module by inserting the micro sims applicable for your modems into the device. Remove the screw (1) holding the access plate in place that covers the sim slots. Use a #1 Phillips screw driver. The access plate is located on the side of the module, as shown in the following:

Figure 5: Sim Access Plate Removal

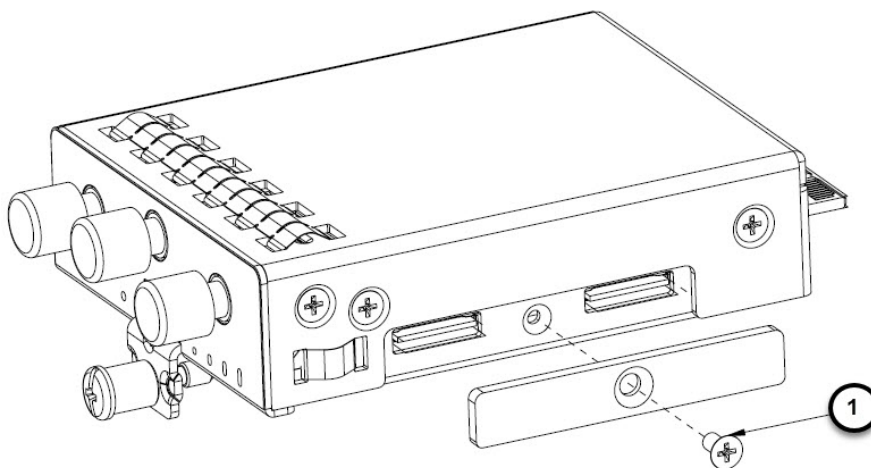

Step 4 Install your sims as shown in the following. Make note of the proper slot number and sim orientation.

Figure 6: Sim Installation

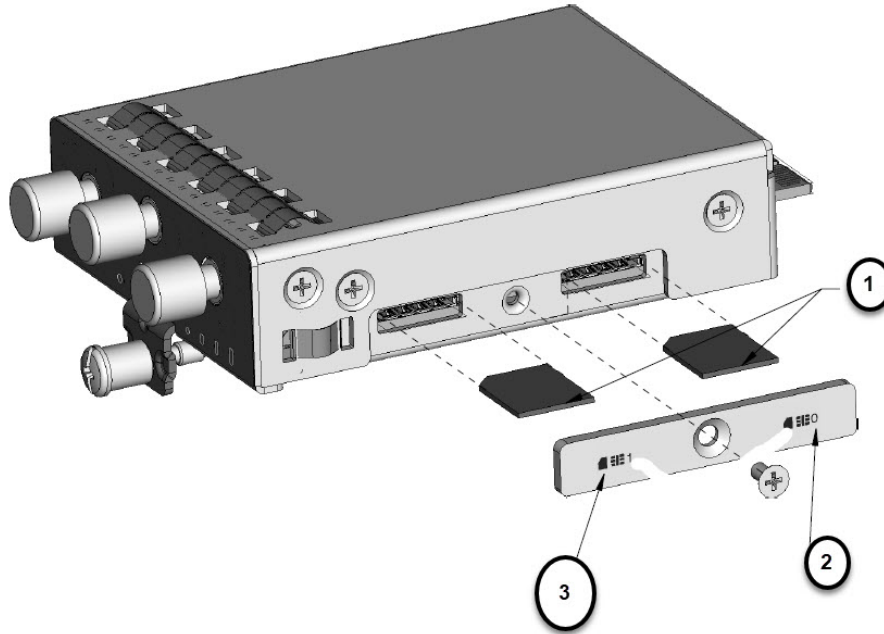

Item	Description
1	Micro SIMs
2	SIM 0 (towards the device)
3	SIM 1 (away from device)

Step 5 Push in each SIM until it clicks into place. When the SIMs are installed, re-attach the access plate previously removed with a #1 Phillips screwdriver. Torque to 2.8 to 3.8 inch-lbs (0.9-1.1 newton meter).

Note Ensure the cover is properly aligned with the screw hole.

Step 6 If your Pluggable Module is the type that has a USB port, make sure that the USB cover is properly installed. Place the USB cover (1) with the plug indentation against the USB port (2). The half circle of the USB cover fits behind the latch lock screw. Refer to the following.

Figure 7: USB Port Cover Installation

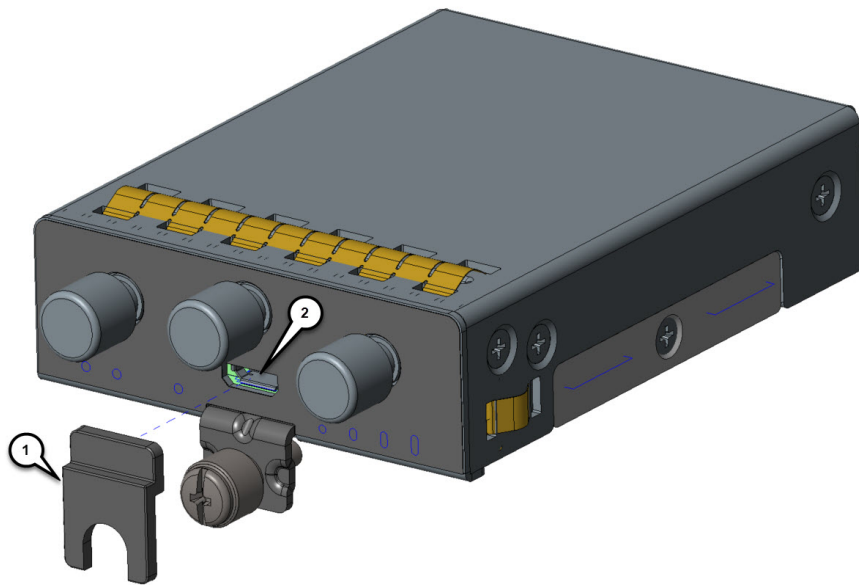

Step 7 Tighten the latch lock screw to a torque of 2.8 to 3.8 inch-lbs (0.3 to 0.4 newton meter). Refer to the following for a finished USB cover installation.

Figure 8: USB Cover Finished Installation

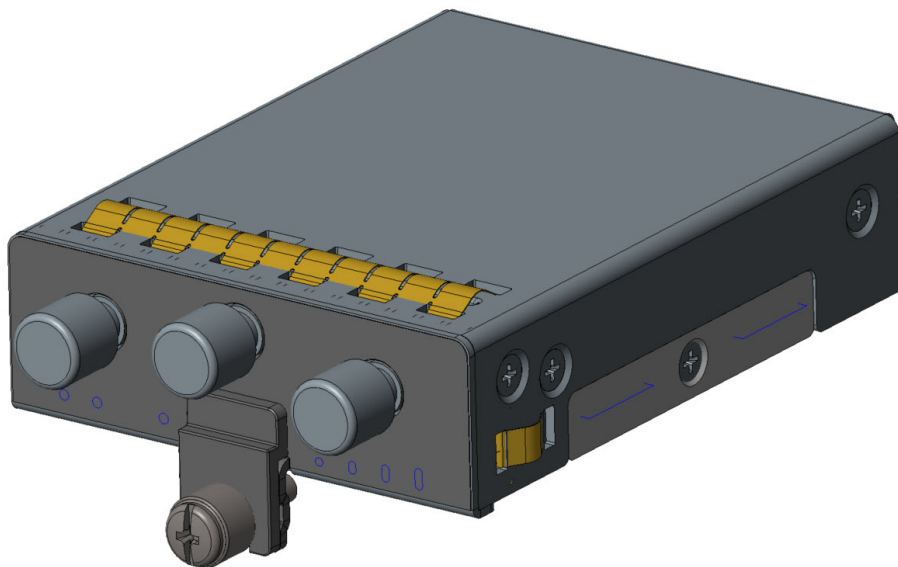

Step 8 Slide the Pluggable Module into the device as shown in the following. The latch lock screw (1) aligns with the screw hole (2) on the front of the device. Push the Pluggable Module all the way into the device until you feel it seat, and then torque the latch lock screw 8-10 inch-pound (0.9 to 1.1 newton meter).

Figure 9: Pluggable Module Insert

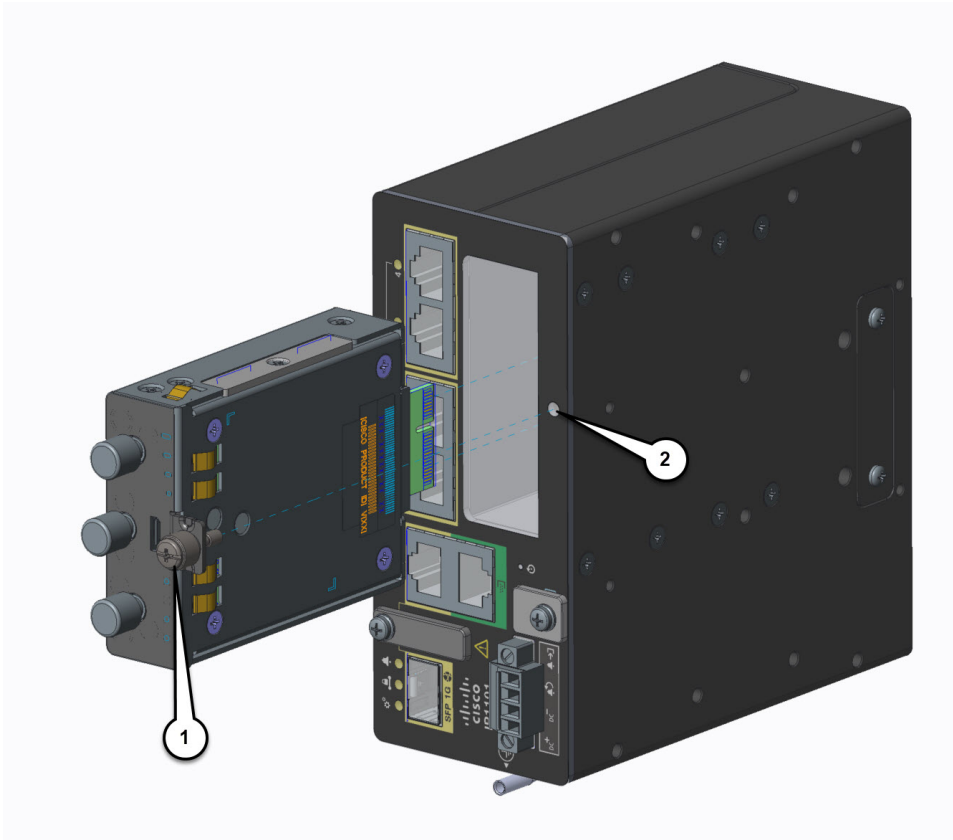

- Step 9** Attach your antennas to the ports on the pluggable module. There are different instructions for each antenna type, be sure to consult the antenna documentation for proper orientation and torque to install them.
- Step 10** If no antennas are being installed on a port, make sure the caps are installed on the connector.

Installing the Router Ground Connection

The router must be connected to a reliable earth ground. Install the ground wire in accordance with local electrical safety standards. There are separate grounding points on the Base IR1101 and the Expansion Module.

- For NEC-compliant grounding, use size 16 awg (1.5mm²) or larger copper wire and a ring terminal with an inner diameter of 1/4 in. (6 to 7mm).
- For EN/IEC 60950-compliant grounding, use size 18 awg (1 mm²) or larger copper wire.



Warning

This equipment must be grounded. Never defeat the ground conductor or operate the equipment in the absence of a suitably installed ground conductor. Contact the appropriate electrical inspection authority or an electrician if you are uncertain that suitable grounding is available. **Statement 1024**



Caution Cable distribution system should be grounded (earthed) in accordance with ANSI/NFPA 70, the National Electrical Code (NEC), in particular Section 820.93, Grounding of Outer Conductive Shield of a Coaxial Cable.

To install the ground connection, follow these steps:

- Step 1** Locate the grounding lug (1) attached to the side of the Cisco IR1101. It will be attached underneath two screws. Remove the screws holding it to the router and set it aside for reuse.
- Step 2** Strip one end of the ground wire to the length required for the terminal.
- Step 3** Crimp the ground wire to the grounding lug using the wire crimper.
- Step 4** Attach the grounding lug (1) to the chassis using the screws set aside in step 1. Tighten the screw to a torque of 8 to 10 inch-pound (0.9 to 1.1 newton meter). Refer to the following figure.

Figure 10: Chassis Ground Connection Points



- Step 5** Connect the other end of the ground wire to a known reliable earth ground point at your site.
- Step 6** If you are using this router in a vehicle, attach the ring terminal to the chassis using one of the screws provided and the green or green and yellow striped wire. Connect the other end of the wire to the vehicle ground.

What to do next

After you install and properly ground the router, you can connect the power wiring, the LAN cables, and the cables for administrative access as required for your installation.

Installing a DIN Rail

The DIN Rail kit is ordered separately.



Note The DIN Rail can be installed on the Base IR1101 in two different orientations, horizontally and vertically. If the Base IR1101 has an Expansion Module attached, horizontal DIN mounting is not supported.



Warning A minimum of 1 inch clearance is required on all sides of the device except for the side mounted against the wall/floor or DIN rail, to allow for proper air flow.

To attach the DIN rail bracket to the Cisco IR1101, follow these steps.

Mounting the DIN Rail Bracket on the Router

Step 1 First, attach the DIN rail bracket to the back of the router. The DIN rail bracket mounts in two different ways, depending on the orientation you wish to use. See the following two figures for vertical orientation, and for horizontal orientation.

Figure 11: Attaching the DIN Rail Bracket for vertical mounting

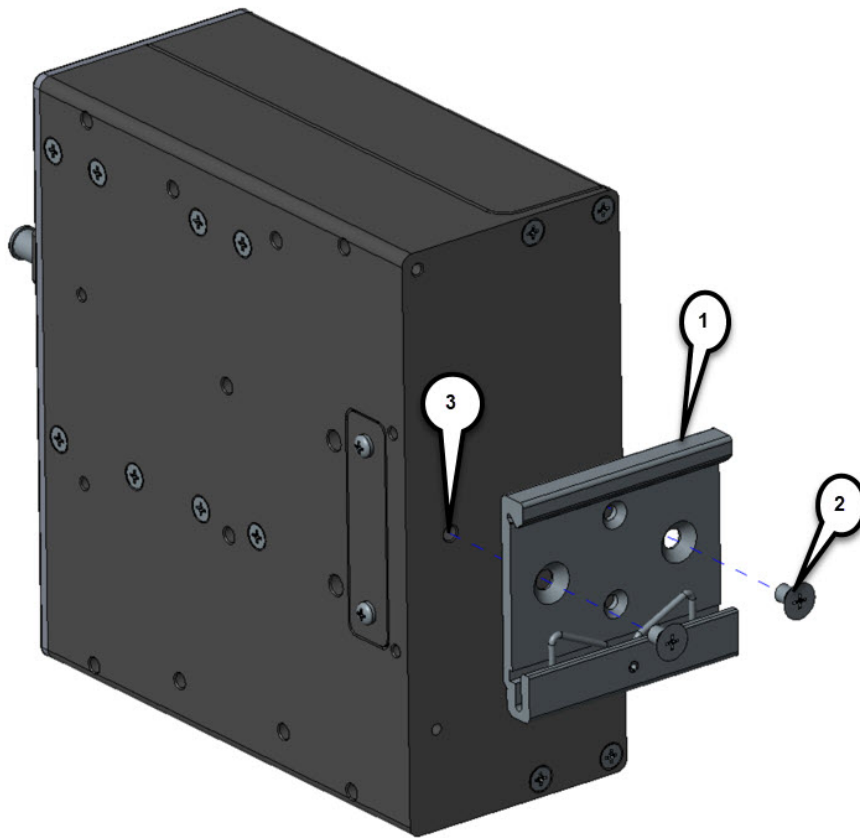

1	DIN mounting bracket
2	Screws from kit
3	Mounting holes

Note Position the router with the ground lug facing down for vertical mounting.

Figure 12: Attaching the DIN Rail Bracket for horizontal mounting

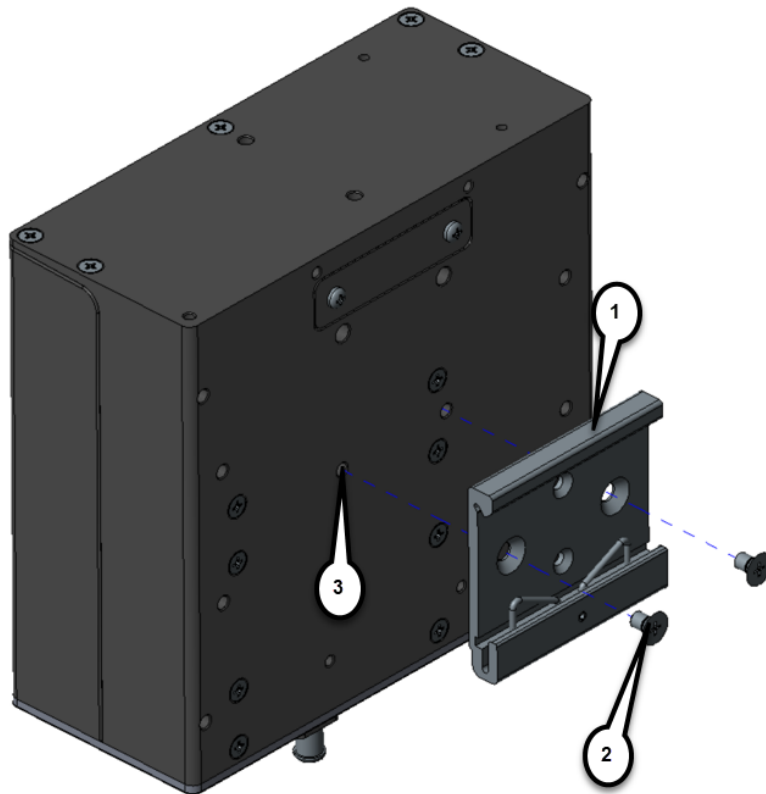

1	DIN mounting bracket
2	Screws from kit
3	Mounting holes

Note Position the router with the front ports facing down for horizontal mounting.

- Step 2** Attach the DIN mounting bracket to the router using the two screws provided in the kit. Position the bracket over the two mounting holes that correspond to your orientation. Use 13-15 in. lbs. of torque to screw the bracket onto the router.
- Step 3** Once the bracket is attached to the router, it can be mounted onto the DIN Rail.

Attaching the Bracket onto the DIN Rail

To attach the Cisco IR1101 with the bracket to a DIN rail, follow these steps. Refer to the following figure for details of a completed attachment.

Figure 13: Bracket Attached to the DIN Rail

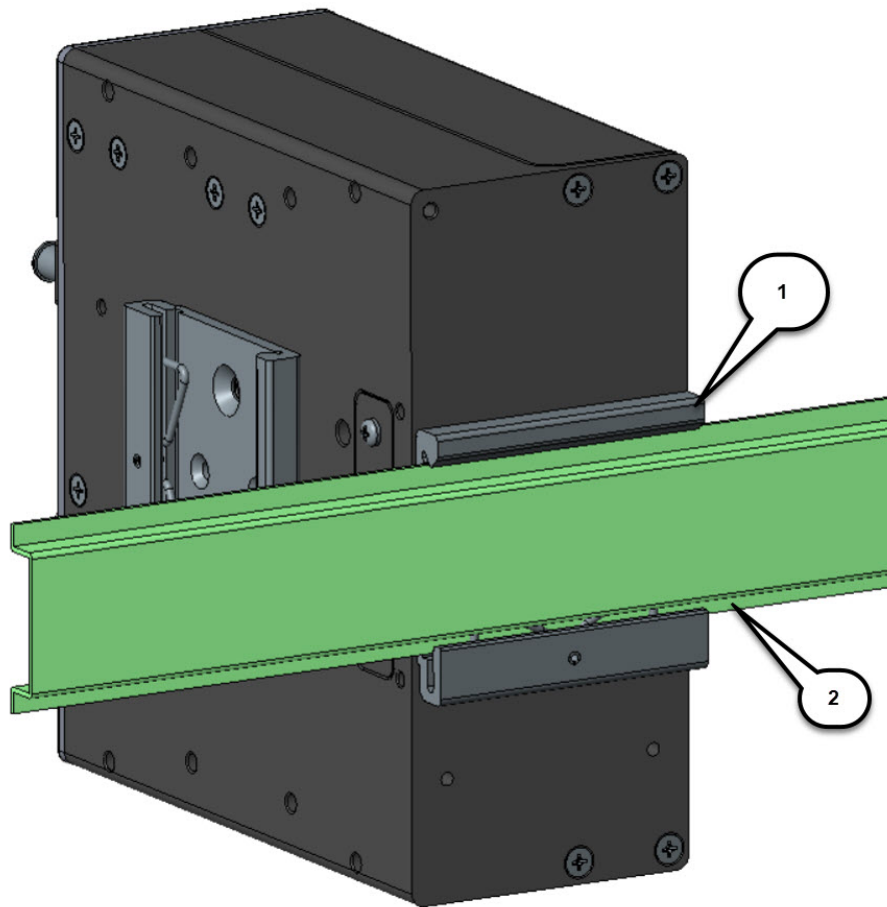

1	DIN rail bracket
2	DIN rail

Step 1 Position the router so that the lower edge and spring of the DIN clip, located within the bottom of the DIN rail bracket, engages with the bottom section of the DIN rail. Push up to compress the spring.

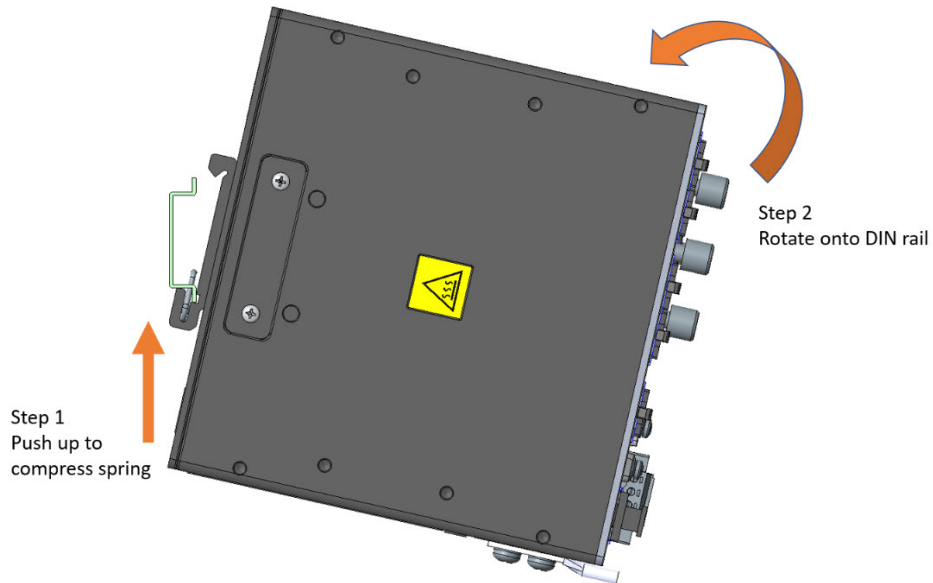

Step 2 Rotate the router so that the top hook of the DIN clip clamps to the top section of DIN rail. Refer to the following figures.

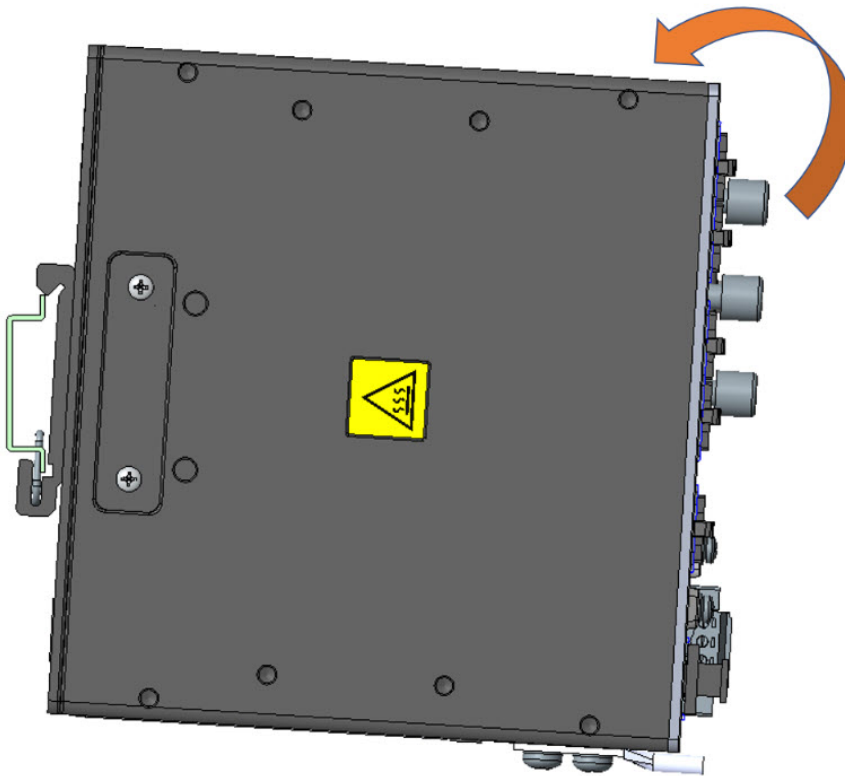

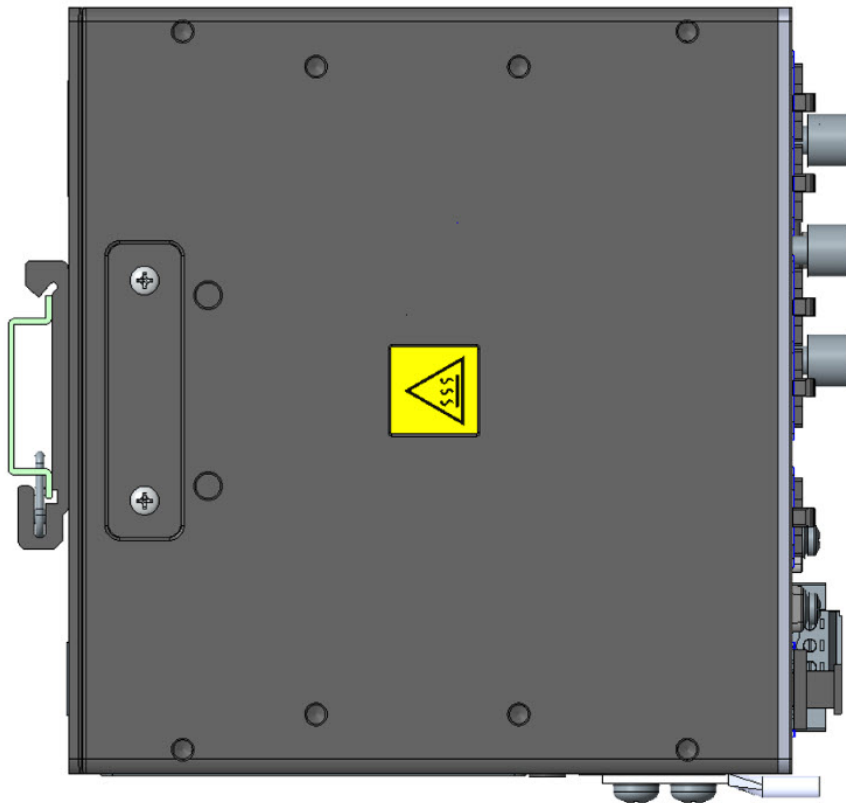

What to do next



Note The procedure to attach the unit to the rail is the same with both orientations.



Note In order to prevent excessive side to side movement of the unit it is advised to install DIN rail stop plates such as Mouser part Numbers 653-PFP-M, 651-1201662 or 845-CA402. These stop plates can be installed on one or both sides of the unit to limit excessive side to side movement that typically occurs in high vibration environments.

Removing the Router from the DIN Rail

To remove the Cisco IR1101 with the bracket from the DIN rail, follow these steps.

Step 1 Press up on the router to compress the spring in the DIN rail clip.

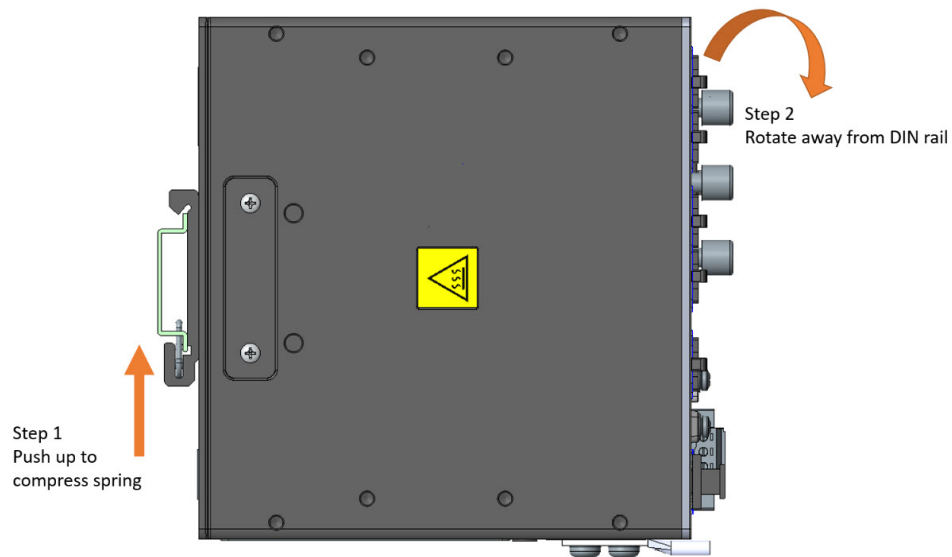

Step 2 Grasp the upper part of the router and rotate it away from the DIN rail. Refer to the following figure.

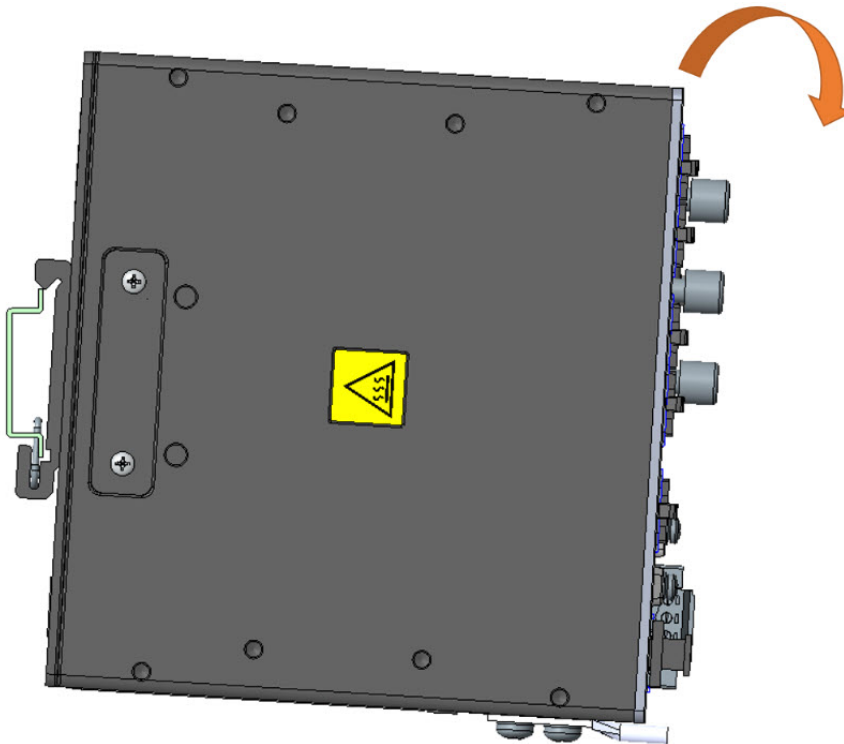

Step 3 Lower the router away from the DIN rail and remove it. Refer to the following figure.

