



Installing the IRM-1100 Expansion Module

This section contains the following:

- [IRM-1100 Expansion Module Overview, on page 1](#)
- [Items Shipped with your Expansion Module, on page 1](#)
- [Installing the Expansion Module, on page 2](#)
- [Mounting the IR1101 Router with the IRM-1100 Expansion Module Attached, on page 4](#)
- [Installing a DIN Rail, on page 8](#)
- [Pluggable Module, on page 12](#)
- [Digital I/O Connections, on page 12](#)
- [Installing the mSATA SSD, on page 14](#)

IRM-1100 Expansion Module Overview

This chapter describes the equipment, and the procedures for successfully installing the Cisco IRM-1100 Expansion Module onto the IR1101. There are two different Expansion Modules available:

- IRM-1100-SPMI
- IRM-1100-SP

Details on both Expansion Modules can be found in the [Product Overview](#) chapter.

Items Shipped with your Expansion Module

Unpack the box and verify that all items listed on the invoice were shipped with the Cisco IRM-1100.

The following items are shipped with your Expansion Module:

- 4 mating screws to connect the IRM-1100 to the IR1101

Installing the Expansion Module

This section describes how to install the Cisco IRM-1100. The Expansion Module attaches to the IR1101 Base using 4 mating screws, and is connected through a mating connector. The Expansion Module is grounded and powered through the connection to the IR1101.

To attach the IRM-1100 to the IR1101, perform the following steps:

- Step 1** Remove the protective cover from the mating connector on the IR1101 by unscrewing the two Phillips head screws. Refer to the following.

Figure 1: Protective Cover



- Step 2** After removing the protective connector cover from the IR1101, carefully align the Expansion Module to the IR1101 so that both mating connectors engage. Refer to the following figure. Once properly seated, install the four mating screws to fully secure the Expansion Module to the IR1101.

Figure 2: Mounting the Expansion Module

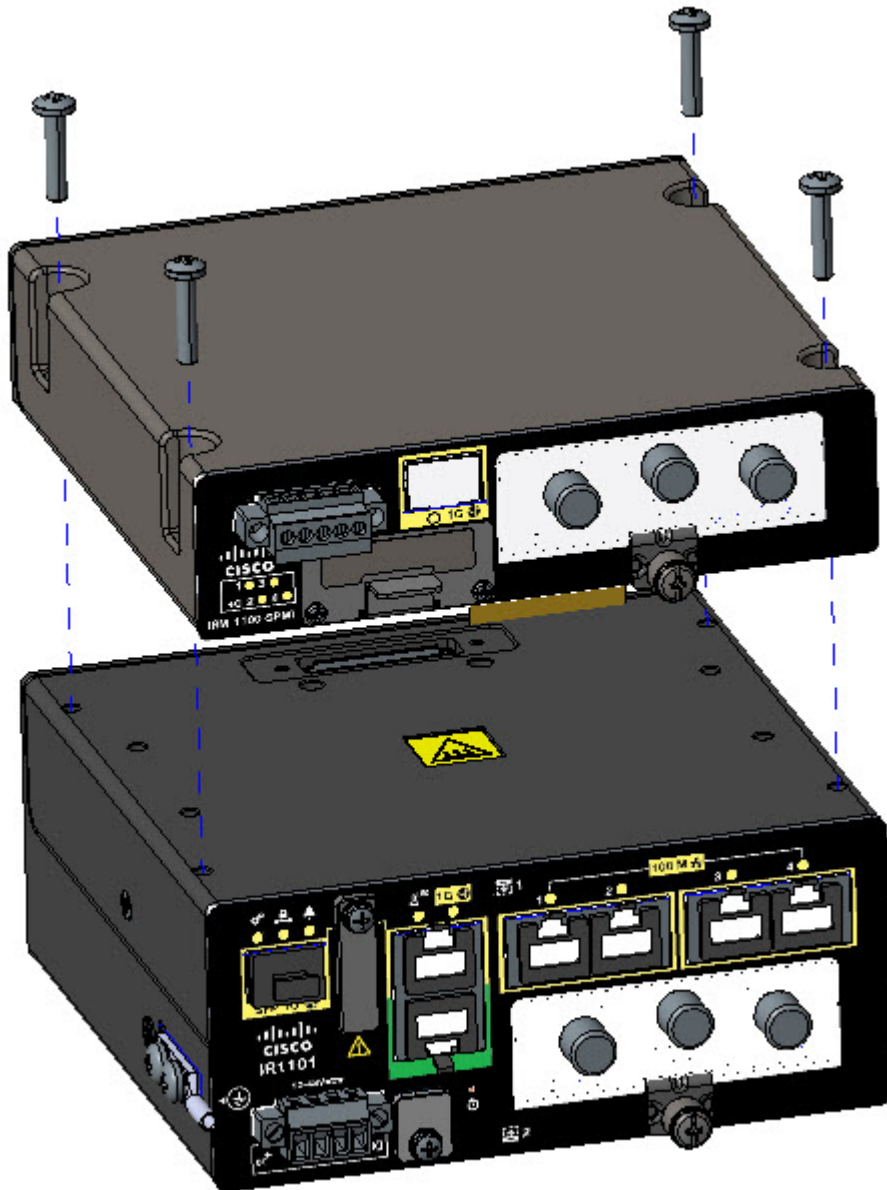

- Step 3** Tighten the screws to a torque of 13-15 in. lbs (1.5-1.7 newton meter). When complete, the two devices form a single assembly as shown in the following figure.

Figure 3: Completed Assembly



Mounting the IR1101 Router with the IRM-1100 Expansion Module Attached

After the Cisco IRM-1100 is attached to the IR1101, it can be mounted in the following ways:

- On a DIN Rail
- Using mounting brackets



Note For the remainder of these instructions, we will refer to the combined IR1101/IRM-1100 as the “Device”.

Mounting the Device Using Mounting Brackets

The wall mounting kit contains the following:

- Mounting brackets (x2)
- Mounting screws (x4)



Warning Read the wall-mounting instructions carefully before beginning installation. Failure to use the correct hardware or to follow the correct procedures could result in a hazardous situation to people and damage to the system.
Statement 378



Warning A minimum of 1 inch clearance is required on all sides of the device except for the side mounted against the wall/floor or DIN rail, to allow for proper air flow.



Tip When choosing a location for wall-mounting a router, consider cable limitations and wall structure, and consider suitable antenna location ahead of time.

The Device can be mounted on the top of a flat surface as shown in the following figure, but cannot be mounted upside down.

Figure 4: Table Mounting

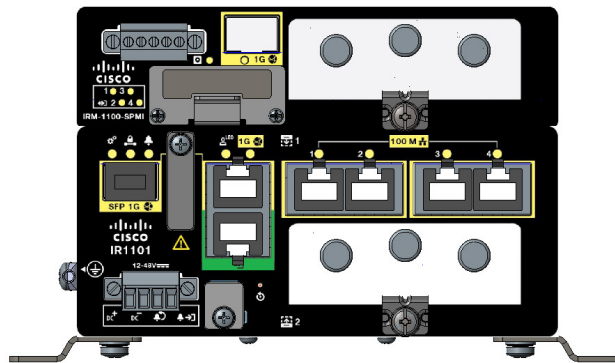

The device can also be mounted vertically on a wall in four orientations as shown in the following figure.

Figure 5: Wall Mounting

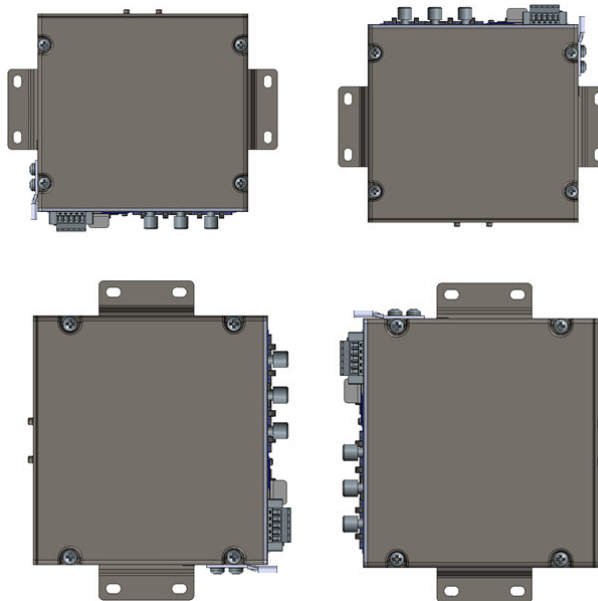

To mount the Device on a wall or other flat surface, follow these steps:

Step 1 Attach the mounting brackets to the bottom of the Device. Refer to the following figure for guidance.

Figure 6: Mounting Brackets

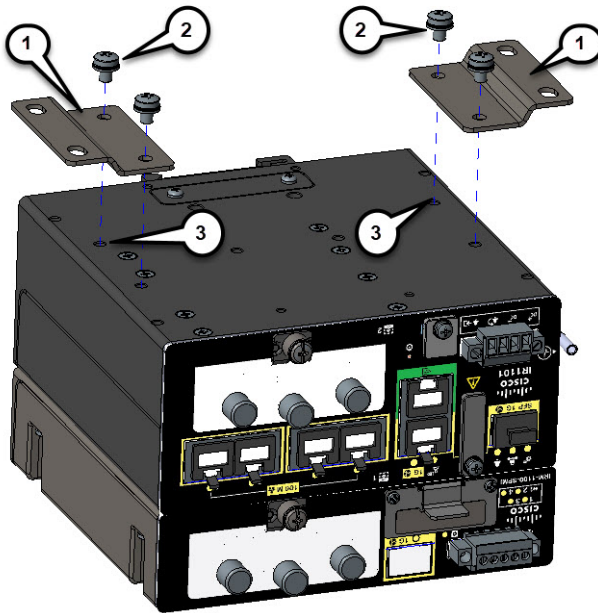

- Step 2** Align the mounting brackets (1) over the mounting holes (3) so that the larger holes on the brackets extend out over the Device.
- Step 3** Attach the brackets to the Device with the 4 screws (2) provided using a Phillips head driver. Torque to 13-15 in. lbs (1.5-1.7 newton meter).
- Step 4** Mount the Device with the attached brackets in a proper wall structure to carry the weight of the device, which is a combined 3.85 lbs. See the following figures for the dimensions of the mounting holes with the brackets attached to the Device.

Figure 7: Wall/Floor mounting hole dimensions with mounting brackets attached

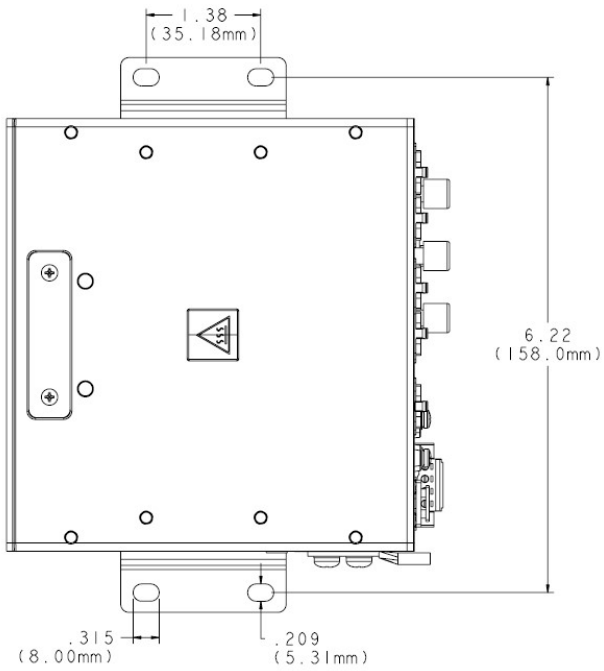

Note Four #10-32 screws are recommended when mounting the Device with these brackets attached to the neighboring surface.

Figure 8: Wall/Floor mounting clearance and overall dimensions with mounting brackets attached

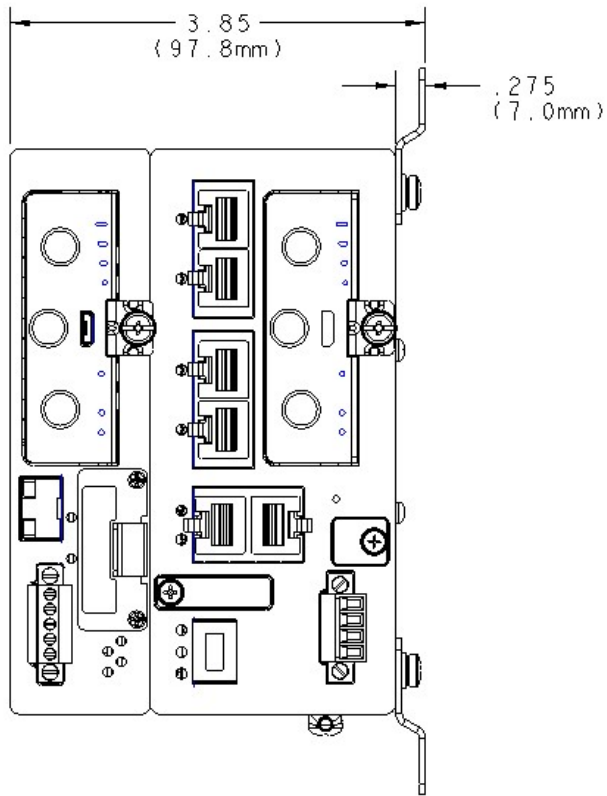

Step 5 Route the cables so that they do not put a strain on the connectors or mounting hardware.

Installing a DIN Rail

The DIN Rail kit is ordered separately. The Device can only be mounted vertically, with the ground lug on the bottom side as shown in the following figure.

Figure 9: Device Orientation

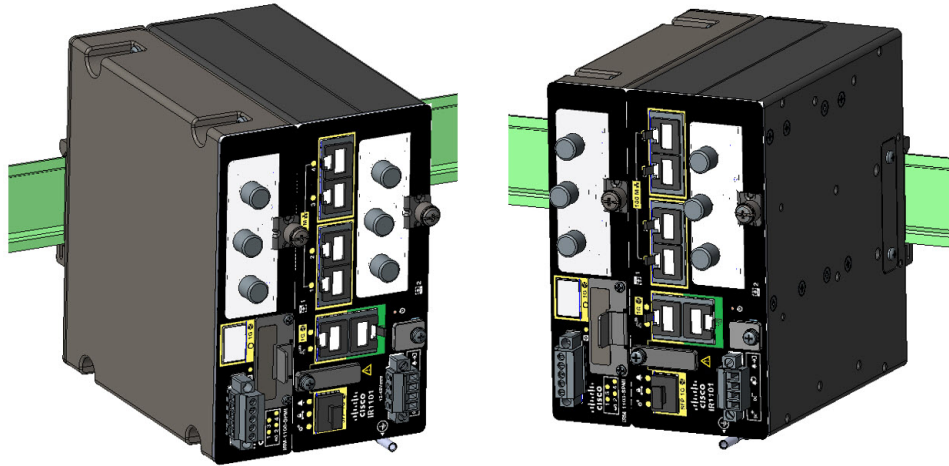

Mounting the DIN Rail Bracket on the Device

Step 1 First, attach the DIN rail brackets to the back of the Device. There are two separate mounting brackets. One attaches to the IR1101, and the other attaches to the IRM-1100. The combined DIN rail brackets mount in the vertical orientation only. See the following figure.

Figure 10: Attaching the DIN Rail Brackets

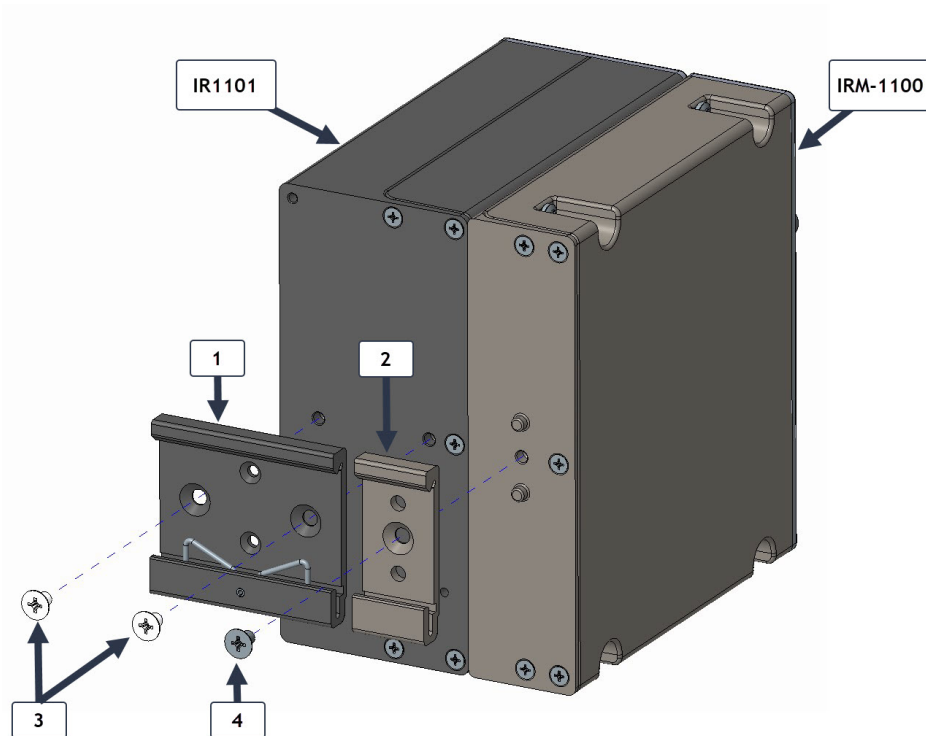

Attaching the Bracket onto the DIN Rail

1	DIN mounting bracket
2	IRM-1100 DIN mounting bracket
3	Screws from kit
4	Screws from IRM-1100 kit

- Step 2** Attach the IR1101 DIN mounting bracket to the Device using the two screws provided in the kit. Position the bracket over the two mounting holes, then use 13-15 in. lbs. (1.5-1.7 newton meter) of torque to screw the bracket onto the Device.
- Step 3** Attach the IRM-1100 DIN mounting bracket to the Device using the screw provided in the kit. Position the bracket over the single mounting hole, then use 13-15 in. lbs. (1.5-1.7 newton meter) of torque to screw the bracket onto the Device.
- Step 4** Once the two brackets are attached to the Device, it can be mounted onto the DIN Rail.

Attaching the Bracket onto the DIN Rail

To attach the Device with the brackets to a DIN rail, follow these steps. Refer to the following figure for details.

Figure 11: Attaching the Brackets to the DIN Rail

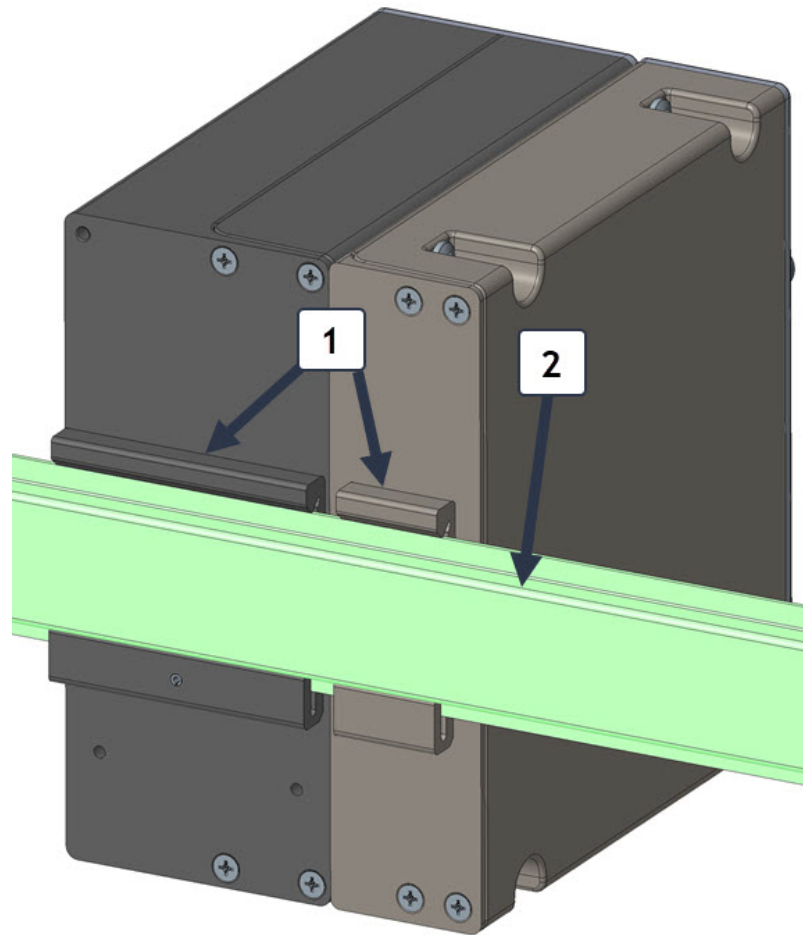

Step 1 Position the Device so that the lower edge and spring of the Din clips (1) engages with the bottom section of the Din rail (2).

Step 2 Push up on the Device so that the spring of DIN clips (1) compresses against the lower section of DIN rail (2) and then rotate the Device so that the top hook of the DIN clips (1) clamps to the top section of DIN rail (2).

Step 3 To remove the Device from the DIN Rail, simply reverse the procedure.

Note In order to prevent excessive side to side movement of the unit it is advised to install DIN rail stop plates such as Mouser part Numbers 653-PFP-M, 651-1201662 or 845-CA402. These stop plates can be installed on one or both sides of the unit to limit excessive side to side movement that typically occurs in high vibration environments.

Step 4 If you are using this Device in a vehicle, attach the ring terminal to the chassis using one of the screws provided and the green or green and yellow striped wire. Connect the other end of the wire to the vehicle ground.

What to do next

After you install and properly ground the Device, you can connect the power wiring, the LAN cables, and the cables for administrative access as required for your installation.

Pluggable Module

The Pluggable Module provides the IRM-1100 with a number of different configuration options. The installation of the Pluggable Module into the Expansion Module is the same as installing it into the IR1101. See that section at [Cisco Pluggable Modules](#).

Digital I/O Connections

The wired Digital I/O connector is show as (1) in the following figure.

Figure 12: Digital I/O connector

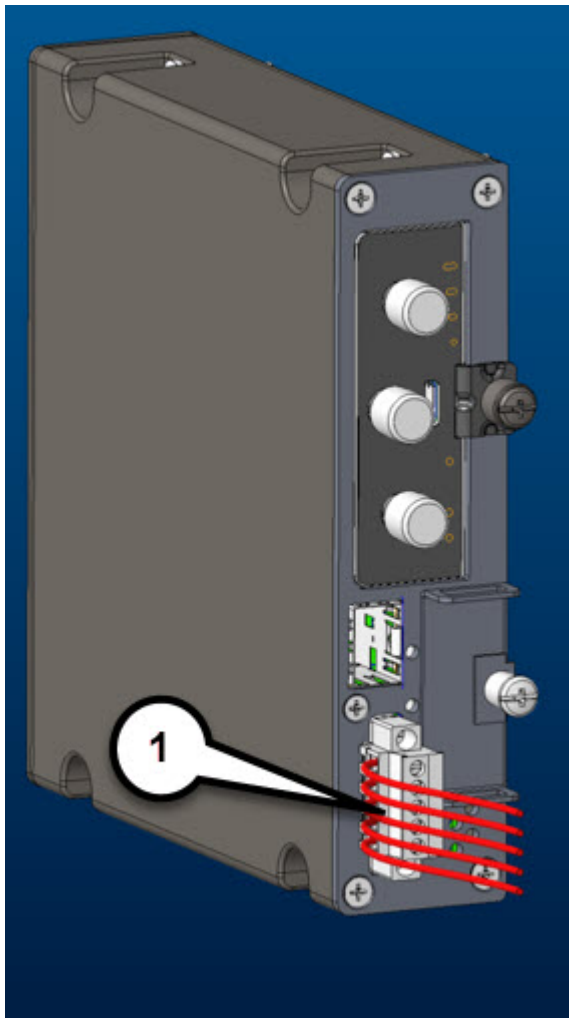

The Digital I/O connector has 4 GPIO connections plus 1 Return connection. The default state of the Digital I/O is input, the open-collector is open (off). Further details on the Digital I/O connector can be found at [Digital I/O Connector](#).

Wiring the Alarm Connections

To wire the alarm connections on your Cisco IR1101 Expansion Module, follow these steps:

-
- Step 1** Locate the alarm connector on the router front panel.
- Step 2** Identify the connectors.
- Step 3** Using a wire-stripping tool, strip each of the alarm wires to 0.25 inch (6.3 mm) \pm 0.02 inch (0.5 mm). Do not strip more than 0.27 inch (6.8 mm) of insulation from the wire. Stripping more than the recommended amount of wire can leave exposed wire from the connector after installation.
- Step 4** Remove the two captive screws that attach the alarm connector to the Expansion Module, and remove the connector.
- Step 5** On the alarm connector, insert the exposed part of the wire into the connection. Make sure that you cannot see any wire lead. Only wire with insulation should extend from the connector. See the following figure.

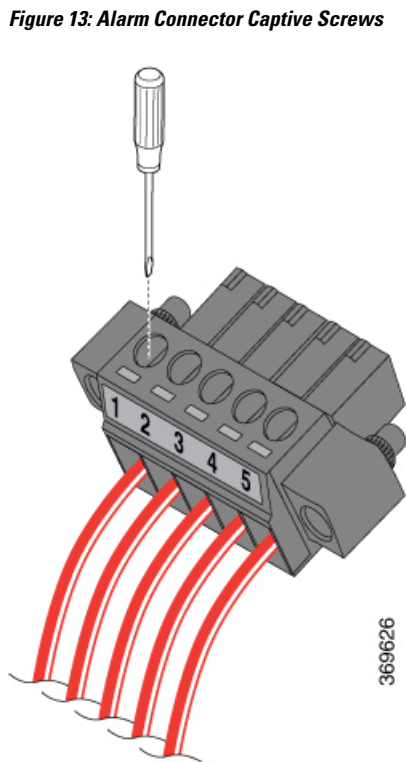

- Step 6** Use a ratcheting torque flathead screwdriver to torque the power connector captive screws (above the installed wire leads) to 2 in-lb (0.23 N-m).
- Step 7** Connect the other end of the wires to the alarm source, and re-attach the alarm connector to the Expansion Module.
-

Installing the mSATA SSD

Mini-SATA, or mSATA, is a low-profile interface connector that enables more effective Serial ATA (SATA) integration in small form-factor drives roughly the size of a business card, such as solid state disks (SSDs).

This section provides an overview of the mSATA SSD available for the Cisco IRM-1100 Expansion Module.

mSATA Installation Instructions



Note Ensure that you are using proper static discharge techniques such as a wrist strap and static mat.



Caution Ensure the device is powered down before performing any removal or installation of a module.

The mSATA SSD module plugs into the slot shown in the following figure.

Figure 14: Cisco IRM-1100-SPMI Front Panel

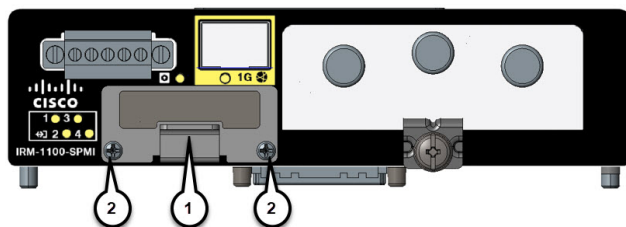

Item	Description
1	mSATA Module Slot
2	Module Captive Screws

Perform the following steps in order in install the module.

-
- Step 1** Remove the two screws (2) holding the cover of the mSATA Slot.
- Step 2** Insert the mSATA SSD module into the slot on the IRM-1100-SPMI. Refer to the following figure for guidance.

Figure 15: Module Placement

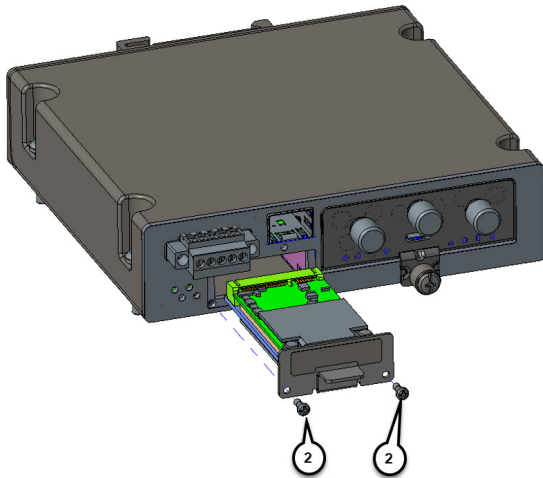

- Step 3** After the module is properly inserted, tighten the module plate to the IRM-1100-SPMI with the two screws (2). The screws should be torqued to 2-3 in-lb (0.2-0.3 newton meter).
- Step 4** The installation is now complete.
-

