



Deployment Topologies

Routed Optical Networking supports these deployment topologies:

- **Metro and Regional:** This topology is used for shorter reach metro use cases and longer regional use cases.
- **Long Haul:** This topology is used for distances greater than 400 km.

The QDD-400G-ZR-S optic has a maximum reach of 120 km. Longer distances require the use of QDD-400G-ZRP-S optics.

The Routed Optical Networking solution architecture or network design is the same for any network such as core, aggregation, or DCI. The only differentiating factor is the hardware that is used for any deployment.

- [Components and connections in metro and regional topology, on page 1](#)
- [Components and connections in mesh topology, on page 4](#)
- [Components and connections in long haul topology, on page 10](#)
- [Components and connections in point-to-point topology with NCS 1010 nodes, on page 16](#)
- [Components and connections in multi-degree topology with NCS 1010 nodes , on page 18](#)

Components and connections in metro and regional topology

Topology diagram

This topology diagram illustrates the setup for metro and regional networks.

Figure 1: 400G-ZR P2P short haul applications with Cisco NCS 2006

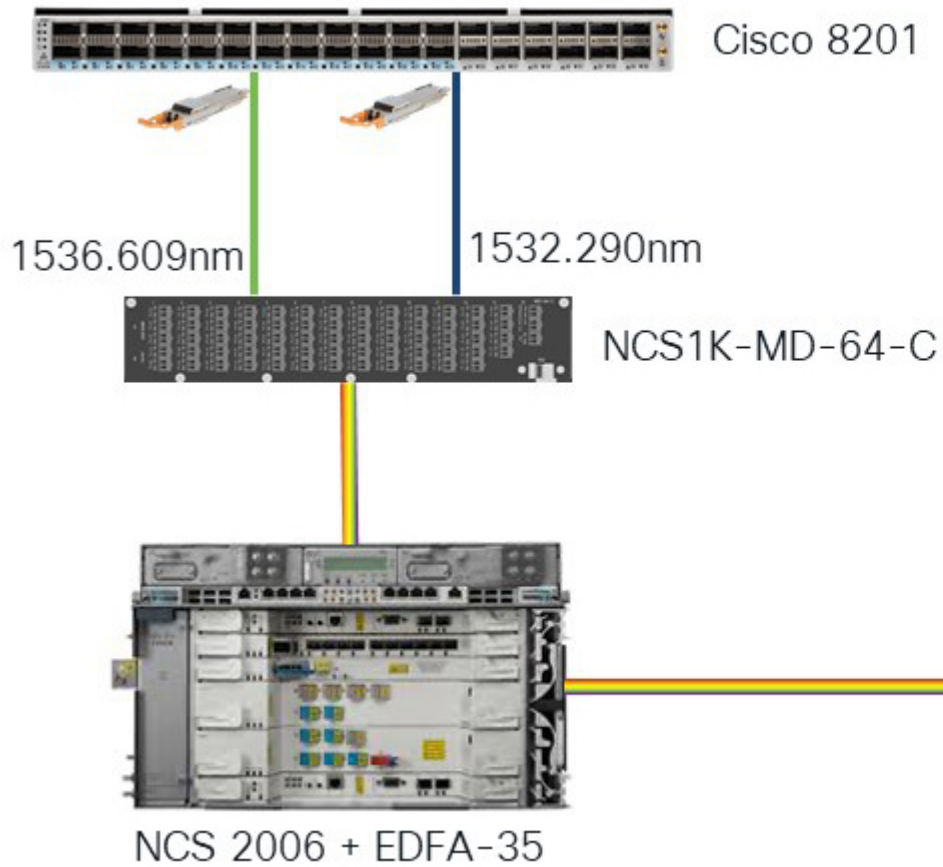

This diagram displays the wiring diagram for the metro and regional topology.

Figure 2: Wiring diagram for a metro and regional topology

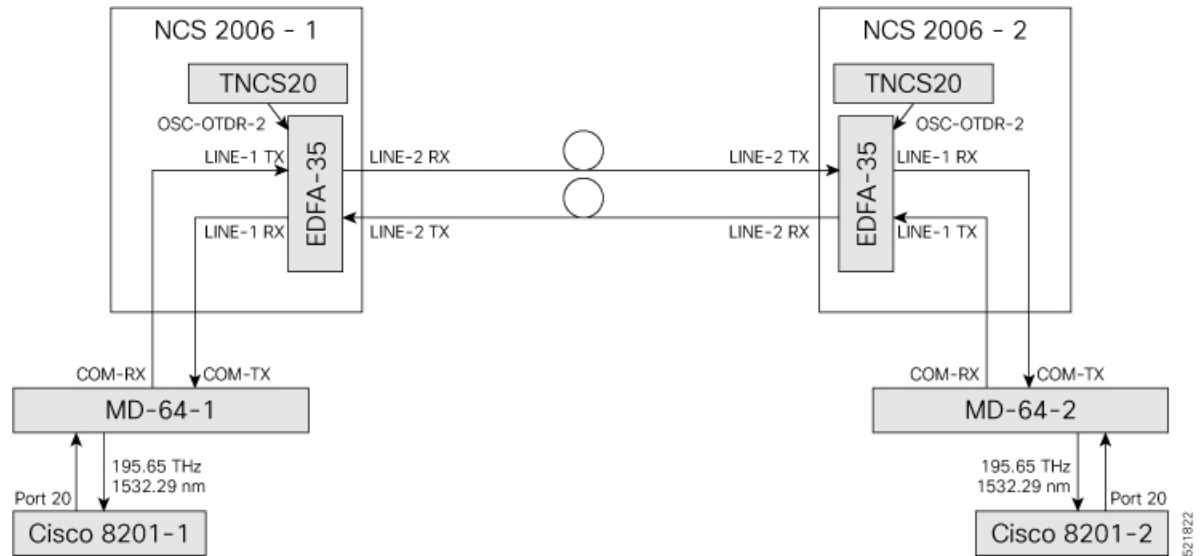

In this sample topology, Cisco 8201-1 serves as the source router and Cisco 8201-2 serves as the destination router.

Topology components

You need this hardware to build this topology:

- Cisco 8200 series routers
- NCS1K-MD-64-C modules
- Cisco NCS 2006 shelves
- TNCS-20 cards
- OPT-EDFA-35 cards
- QDD-400G-ZR-S transceiver module
- LC/LC cables

For more information, see [Hardware components](#).

Port connections

Use this sequence to connect the cables and build this topology:

1. On the Cisco 8201-1 and Cisco 8201-2 routers:
 - a. Align the QDD-400G-ZR-S transceiver module in front of the transceiver socket opening in Port 20. Then, carefully slide the transceiver into the socket until the transceiver comes in contact with the socket electrical connector.
 - b. Holding the pull-tab, fully seat the transceiver in the module's transceiver socket until it clicks.
 - c. Attach an LC/LC fiber immediately to the QDD-400G-ZR-S transceiver module.

- d. Connect the other end of the LC/LC fiber to the corresponding bulkhead adapter on the front panel of the NCS1K-MD-64-C (MD-64-1) module. In this sample topology, we use channel ID 7, which corresponds to a frequency of 195.65 THz (a wavelength of 1532.29 nm).
2. Connect an LC/LC fiber from the COM-RX port of the MD-64-1 module to the LINE-1-TX port of the EDFA 35 amplifier card in NCS 2006-1.
3. Connect an LC/LC fiber from the COM-TX port of the MD-64-1 module to the LINE-1-RX port of the EDFA 35 amplifier card in NCS 2006-1.
4. Connect an LC/LC fiber from the OSC-OTDR-2 port on the TNCS-2O card to the OSC port on the EDFA 35 card in NCS 2001-1.
5. Connect an LC/LC fiber from the LINE-2-RX port of the EDFA-35 card in NCS 2006 -1 to the outside plant fiber that is connected to the LINE-2-TX port of the EDFA-35 card in NCS 2006 -2.
6. Connect an LC/LC fiber from the LINE-2-TX port of the EDFA-35 card in NCS 2006 -1 to the outside plant fiber that is connected to the LINE-2-RX port of the EDFA-35 card in NCS 2006 -2.
7. Connect an LC/LC fiber from the OSC-OTDR-2 port on the TNCS-2O card to the OSC port on the EDFA 35 card in NCS 2006-2.
8. Connect an LC/LC fiber from the LINE-1-RX port of the EDFA-35 card in NCS 2006 -2 to the COM-TX port of the MD-64-2 module.
9. Connect an LC/LC fiber from the LINE-1-TX port of the EDFA-35 card in NCS 2006 -2 to the COM-RX port of the MD-64-2 module.

Next steps

After you build the topology, perform these steps:

- [Import the Cisco ONP Configuration File into SVO.](#)
- [Manage Expected Input Power](#)

Components and connections in mesh topology

Topology diagram

This topology diagram illustrates the setup for mesh networks.

Figure 3: Optical bypass with colorless add/drop and 4-degree ROADM node

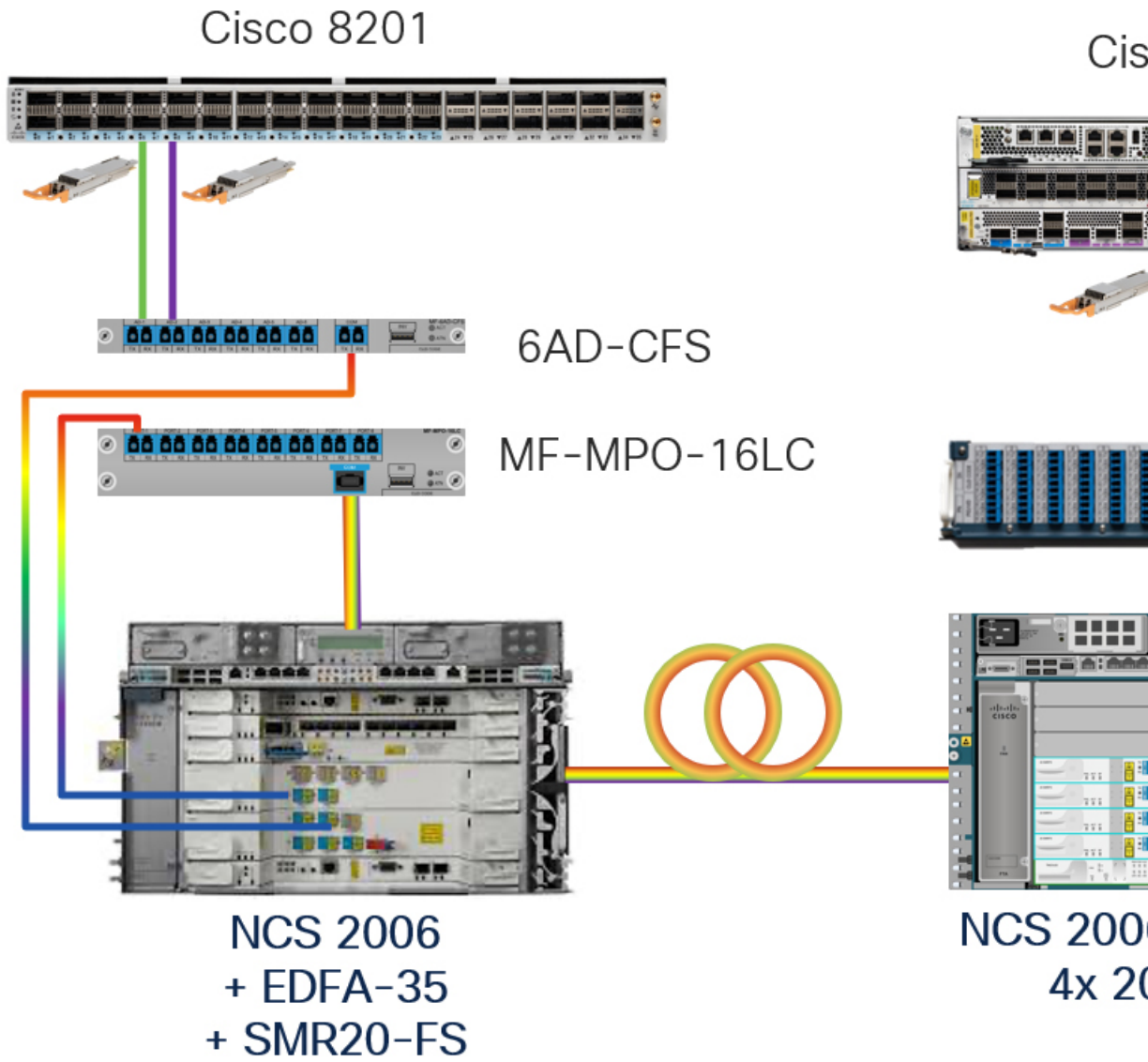

This figure shows the NCS 2006 mesh node in detail with mesh panels.

Figure 4: 4-Degree mesh node configuration

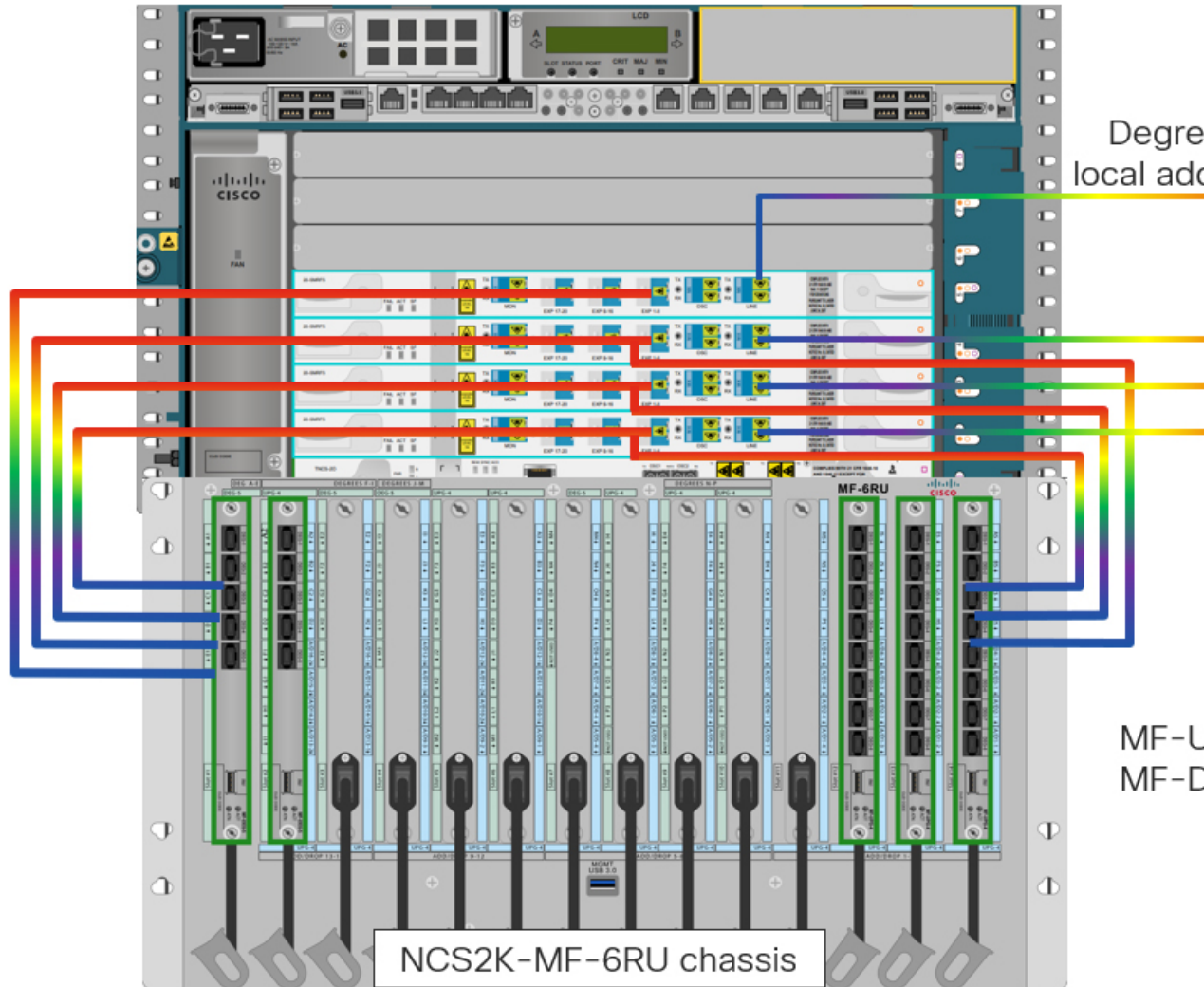

This diagram shows the wiring diagram for the mesh topology.

Figure 5: Wiring diagram for a mesh topology

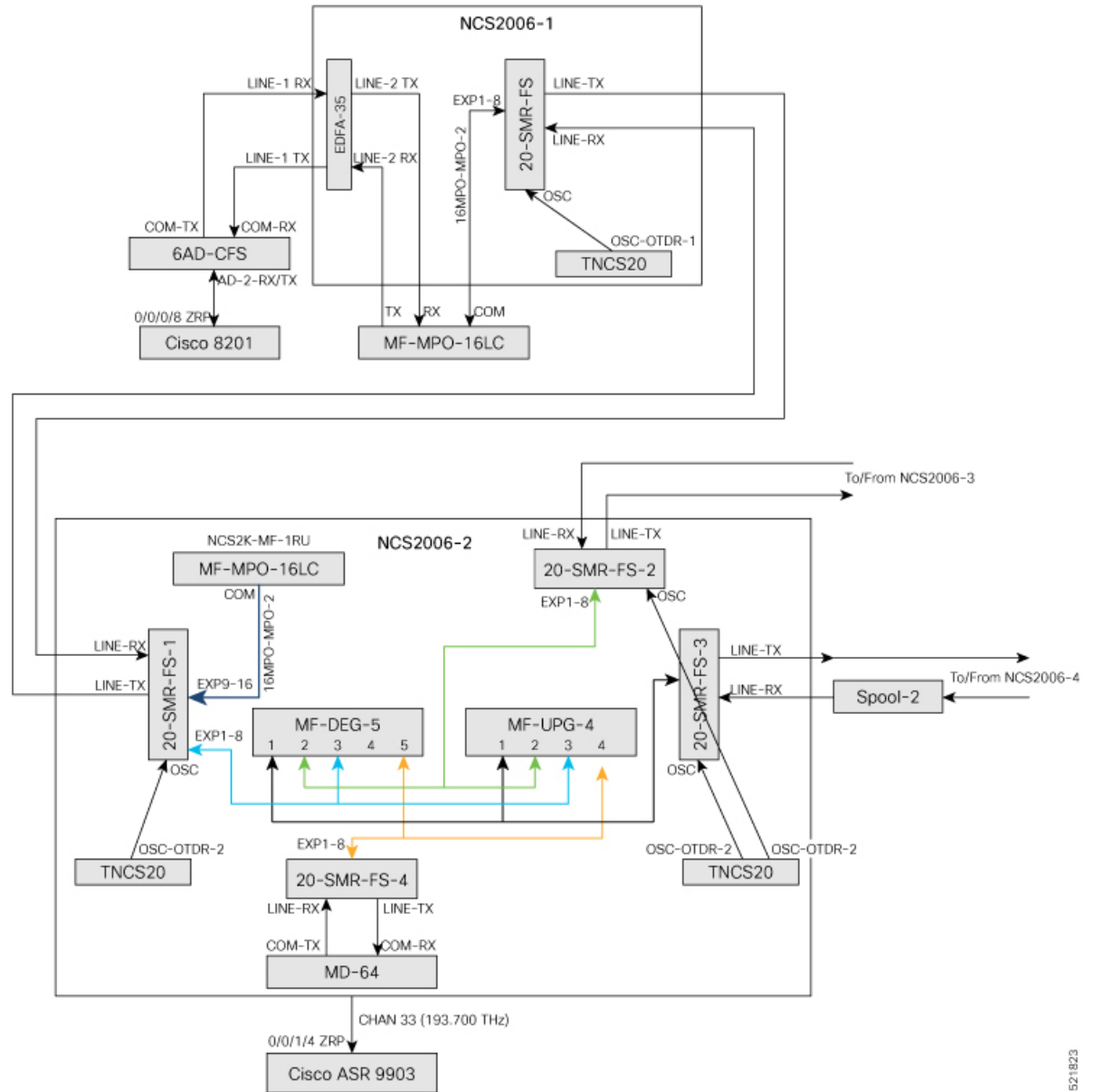

In this sample topology, Cisco 8201 is the source router and Cisco ASR 9903 is the destination router, using a four-degree node. Nodes with fewer or more degrees are also supported. NCS2006-2 is a four-degree mesh node that drops a colored wavelength on the Cisco ASR 9903 router. The MD-64 unit is used as a fixed channel muxponder but other options can also be connected to the 20-SMR-FS card. The other degrees are connected to NCS 2000 nodes in the network.

Topology components

You need this hardware to build this topology:

- Cisco 8200 series routers

521823

- Cisco ASR 9903 routers
- NCS1K-MD-64-C modules
- 6-AD-CFS units
- MF-DEG-5 units
- MF-UPG-4 units
- MF-MPO-16LC units
- Cisco NCS 2006 shelves
- TNCS-2O, OPT-EDFA-35, and 20-SMR-FS cards
- QDD-400G-ZR-S transceiver modules
- LC/LC cables
- 16MPO-MPO-2 cables
- ONS-MPO16-2x8-2 cables

For more information, see [Hardware components](#).

Port connections

Use this sequence to connect the cables and build this topology:

1. On the Cisco 8201 router:
 - a. Align the QDD-400G-ZR-S transceiver module in front of the transceiver socket in port 4. Then, carefully slide the transceiver into the socket until the transceiver comes in contact with the socket electrical connector.
 - b. Holding the pull-tab, seat the transceiver in the transceiver socket of the module fully until it clicks.
 - c. Attach an LC/LC fiber to the QDD-400G-ZR-S transceiver module immediately.
 - d. Connect the LC/LC fiber's other end to the matching bulkhead adapter on the 6AD-CFS module's front panel. (AD-2 RX/TX port). In this sample topology, we use channel ID 33, which corresponds to a frequency of 193.700 THz.
2. Connect an LC/LC fiber from the COM-RX port of the 6AD-CFS module to the LINE-1-TX port of the EDFA 35 amplifier card in NCS 2006-1.
3. Connect an LC/LC fiber from the COM-TX port of the 6AD-CFS module to the LINE-1-RX port of the EDFA 35 amplifier card in NCS 2006-1.
4. Connect an LC/LC fiber from the LINE-2-RX port of the EDFA-35 card in NCS 2006 -1 to the TX port of the MF-MPO-16LC unit.
5. Connect an LC/LC fiber from the LINE-2-TX port of the EDFA-35 card in NCS 2006 -1 to the RX port of the MF-MPO-16LC unit.
6. Connect an 16MPO-MPO-2 fiber from the EXP1-8 port of the 20-SMR-FS card in NCS 2006 -1 to the COM port of the MF-MPO-16LC unit.

7. Connect an LC/LC fiber from the OSC-OTDR-2 port on the TNCS-2O card to the OSC port on the 20-SMR-FS card in NCS 2006 -1.
8. Connect an LC/LC fiber from the LINE-TX port of the 20-SMR-FS card in NCS 2006 -1 to the LINE-RX port of the 20-SMR-FS-1 card in NCS 2006 -2.
9. Connect an LC/LC fiber from the LINE-RX port of the 20-SMR-FS card in NCS 2006 -1 to the LINE-TX port of the 20-SMR-FS-1 card in NCS 2006 -2.
10. Connect an LC/LC fiber from the OSC-OTDR-2 port on the TNCS-2O card to the OSC port on the 20-SMR-FS-1 card in NCS 2006-2.
11. Connect an 16MPO-MPO-2 fiber from the EXP9-16 port of the 20-SMR-FS-1 card in NCS 2006 -2 to the COM port of the MF-MPO-16LC unit.
12. Connect one end of the ONS-MPO16-2x8-2 cable to the EXP1-8 port of the 20-SMR-FS-1 card in NCS 2006 -2. Connect the other two ends to port 3 of the MF-DEG-5 unit and MF-UPG-4 unit respectively.
13. Connect one end of the ONS-MPO16-2x8-2 cable to the EXP1-8 port of the 20-SMR-FS-2 card in NCS 2006 -2. Connect the other two ends to port 2 of the MF-DEG-5 unit and MF-UPG-4 unit respectively.
14. Connect one end of the ONS-MPO16-2x8-2 cable to the EXP1-8 port of the 20-SMR-FS-3 card in NCS 2006 -2. Connect the other two ends to port 1 of the MF-DEG-5 unit and MF-UPG-4 unit respectively.
15. Connect one end of the ONS-MPO16-2x8-2 cable to the EXP1-8 port of the 20-SMR-FS-4 card in NCS 2006 -2. Connect the other end to port 5 of the MF-DEG-5 unit only.
16. Connect an LC/LC fiber from the OSC-OTDR-2 port on the TNCS-2O card to the OSC port on the 20-SMR-FS-2 card in NCS 2006-2.
17. Connect an LC/LC fiber from the OSC-OTDR-2 port on the TNCS-2O card to the OSC port on the 20-SMR-FS-3 card in NCS 2006-2.
18. Connect LC/LC fibers from the LINE-TX and LINE-RX ports of the 20-SMR-FS-2 card in NCS 2006-2 to the ports of NCS2006-3.
19. Connect LC/LC fibers from the LINE-TX and LINE-RX ports of the 20-SMR-FS-3 card in NCS 2006-2 to the ports of NCS2006-4.
20. Connect an LC/LC fiber from the LINE-RX port on the 20-SMR-FS-4 card in NCS 2006-2 to the COM-TX port of the MD-64 unit.
21. Connect an LC/LC fiber from the LINE-TX port on the 20-SMR-FS-4 card in NCS 2006-2 to the COM-RX port of the MD-64 unit.
22. Connect one end of the LC/LC fiber to the corresponding bulkhead adapter on the front panel of the NCS1K-MD-64-C (MD-64-1) module. Connect the other end of the fiber to the QDD-400G-ZR-S transceiver module installed in port 4 of the ASR 9903 router.

Next steps

After you build the topology, perform these steps:

- [Import the Cisco ONP Configuration File into SVO.](#)
- [Manage Expected Input Power](#)

Components and connections in long haul topology

Topology diagram

This topology diagram illustrates the setup for long haul networks.

Figure 6: Long haul setup

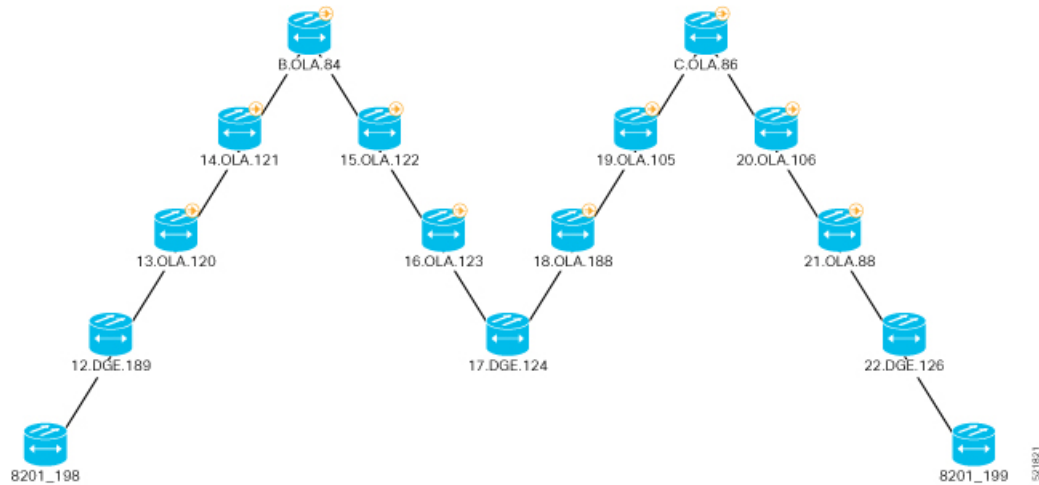

This topology uses several types of nodes, including ILA, terminal, OLA, and DGE nodes. The ILA nodes span from 80 to 120 km. The DGE nodes allow gain equalization in long haul networks over 1200 km. This topology uses terminal, OLA, and DGE nodes.

Figure 7: 400G-ZR P2P long haul applications with Cisco NCS 2006

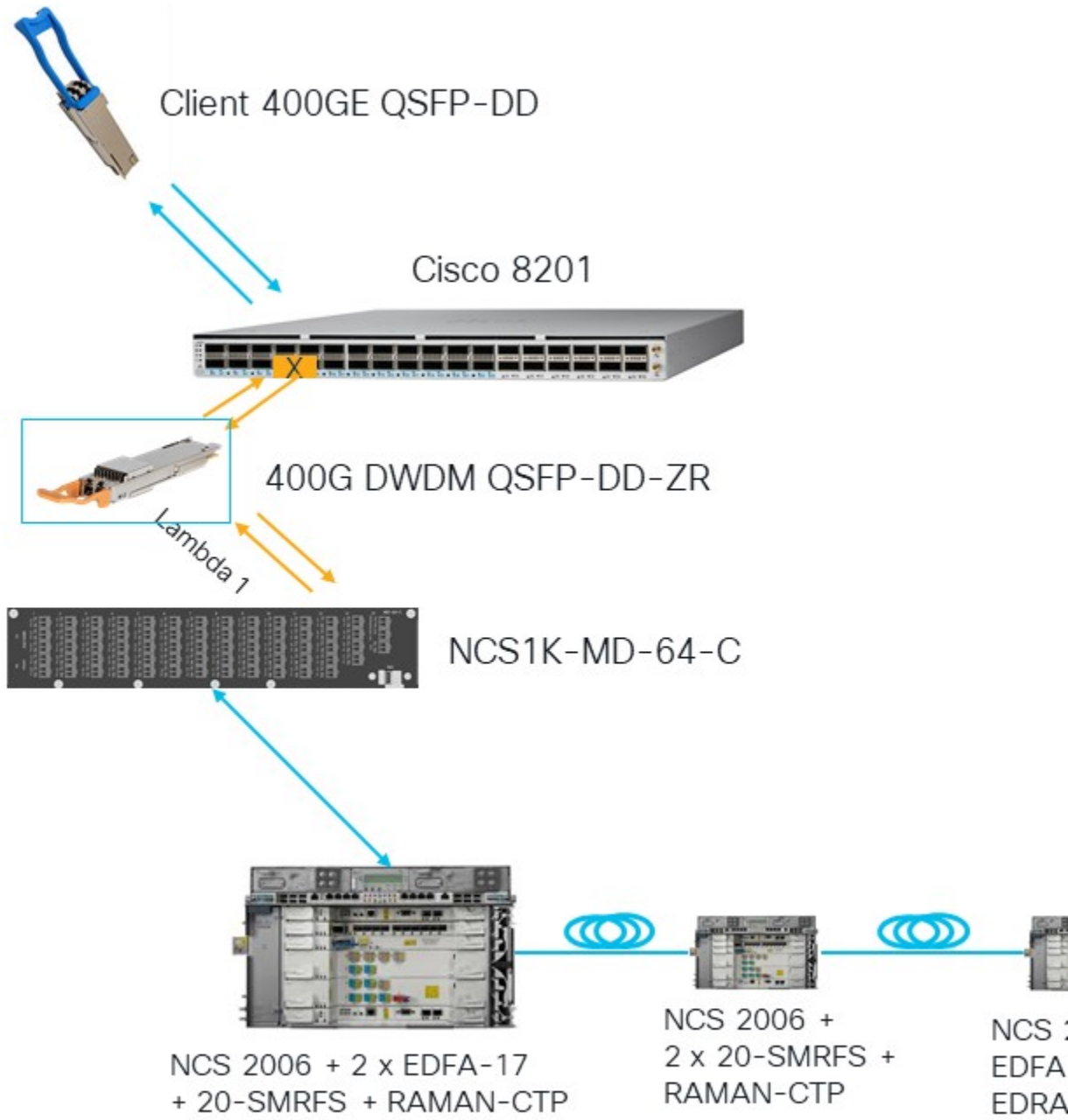

These diagrams show the wiring configuration for the long haul topology.

Figure 8: Wiring diagram for a long haul topology

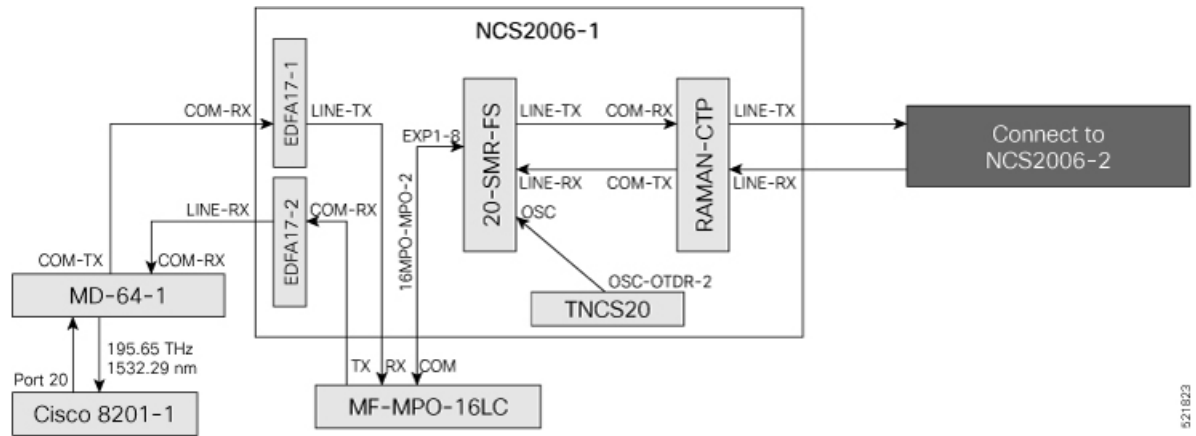

521823

Figure 9: Wiring diagram for a long haul topology

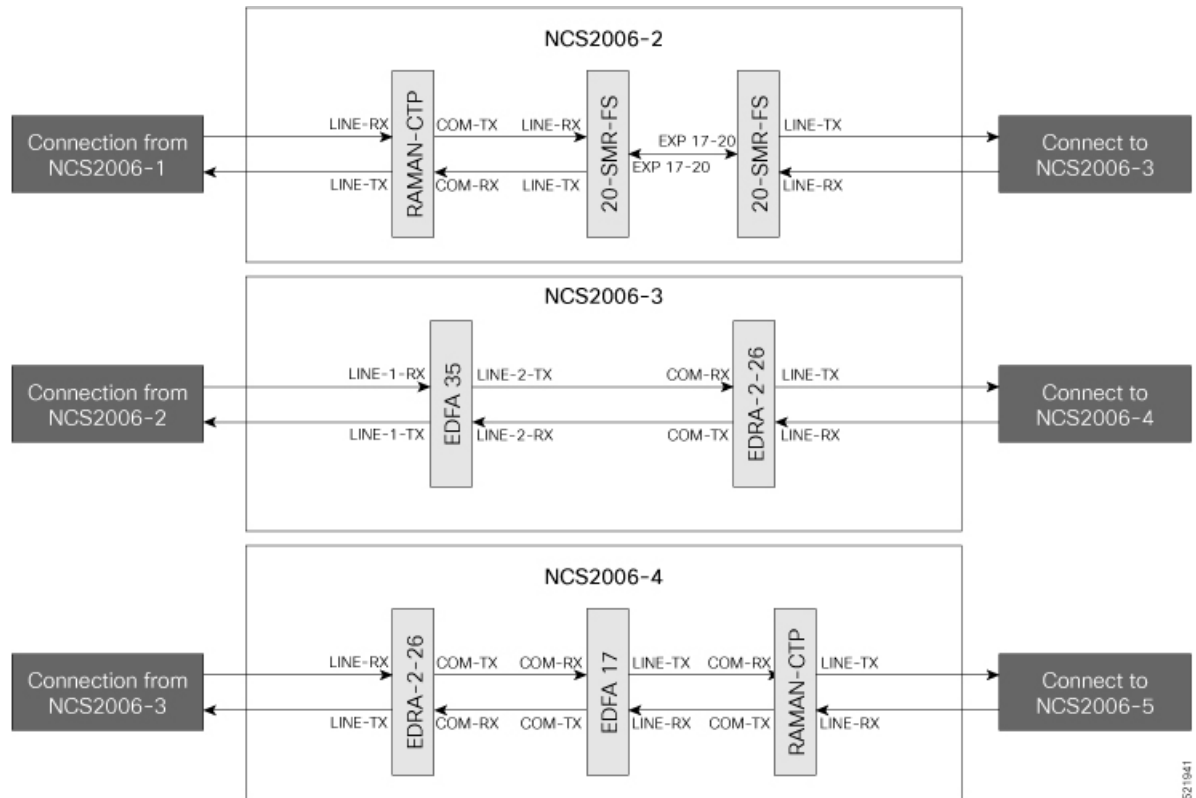

521941

Figure 10: Wiring diagram for a long haul topology

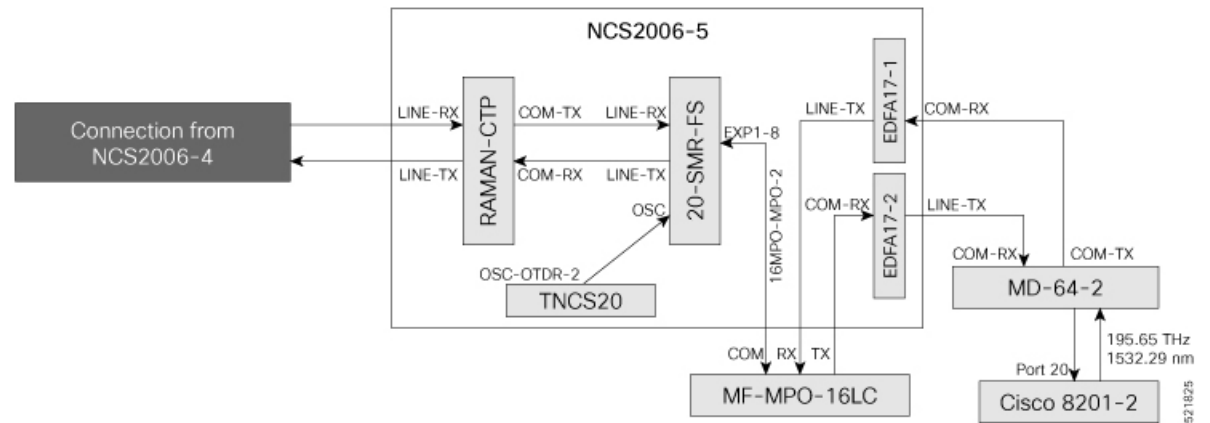

In this sample topology, Cisco 8201-1 is the source router, and Cisco 8201-2 is the destination router.

Topology components

You need this hardware to build this topology:

- Cisco 8200 Series routers
- NCS1K-MD-64-C modules
- Cisco NCS 2006 shelves
- TNCS-20, OPT-EDFA-17, EDRA-2-26, RAMAN-CTP, and SMR20 FScards
- MF-MPO-16LC passive modules (seated in an NCS2K-MF-1RU mechanical frame)
- QDD-400G-ZR-S transceiver
- LC/LC cables
- 16MPO-MPO-2 cables

For more information, see [Hardware components](#).

Port connections

Use this sequence to connect the cables and build this topology:

1. On the Cisco 8201-1 and Cisco 8201-2 routers:
 - a. Align the QDD-400G-ZR-S transceiver module with the transceiver socket opening in Port 20. Then, slide the transceiver carefully into the socket until the transceiver comes in contact with the socket electrical connector.
 - b. Holding the pull-tab, seat the transceiver in the module's transceiver socket fully until it clicks.
 - c. Attach an LC/LC fiber immediately to the QDD-400G-ZR-S transceiver module.
 - d. Connect the other end of the LC/LC fiber to the corresponding bulkhead adapter on the front panel of the NCS1K-MD-64-C (MD-64-1) module. In this sample topology, we use channel ID 7, which corresponds to a frequency of 195.65 THz (wavelength of 1532.29 nm).

2. Connect an LC/LC fiber from the COM-TX port of the MD-64-1 module to the COM-RX port of the EDFA-17-1 amplifier in NCS 2006-1.
3. Connect an LC/LC fiber from the COM-RX port of the MD-64-1 module to the LINE-TX port of the EDFA-17-2 amplifier card in NCS 2006-1.
4. Connect an LC/LC fiber from the LINE-TX port of the EDFA-17-1 amplifier card in NCS 2006-1 to the RX port of the MF-MPO-16LC module.
5. Connect an LC/LC fiber from the COM-RX port of the EDFA-17-2 amplifier card in NCS 2006-1 to the TX port of the MF-MPO-16LC module.
6. Connect a 16MPO-MPO-2 cable from the COM port of the MF-MPO-16LC module to the EXP1-8 port of the 20 SMR-FS card in NCS 2006-1.
7. Connect an LC/LC fiber from the LINE-TX port of the SMR20 card in NCS 2006-1 to the COM-RX port of the RAMAN-CTP card in NCS 2006-1.
8. Connect an LC/LC fiber from the LINE-RX port of the SMR20 card in NCS 2006-1 to the COM-TX port of the RAMAN-CTP card in NCS 2006-1.
9. Connect an LC/LC fiber from the OSC-OTDR-2 port of the TNCS-2O card in NCS 2006 -1 to the OSC-TX port of the SMR20 card in NCS 2006 -1.
10. Connect an LC/LC fiber from the LINE-TX port of the RAMAN-CTP card in NCS 2006-1 to the LINE-RX port of the RAMAN-CTP card in NCS 2006-2.
11. Connect an LC/LC fiber from the LINE-RX port of the RAMAN-CTP card in NCS 2006-1 to the LINE-TX port of RAMAN-CTP card in NCS 2006-2.
12. Connect an LC/LC fiber from the COM-TX port of the RAMAN-CTP card in NCS 2006-2 to the LINE-RX port of the 20-SMR-FS card in NCS 2006 -2.
13. Connect an LC/LC fiber from the COM-RX port of the RAMAN-CTP card in NCS 2006-2 to the LINE-TX port of the 20-SMR-FS card in NCS 2006 -2.
14. Connect an LC/LC fiber from the EXP 17–20 port of the 20-SMR-FS card in NCS 2006-2 to the EXP 17–20 port of the 20-SMR-FS card in NCS 2006-2.
15. Connect an LC/LC fiber from the LINE-TX port of the 20-SMR-FS card in NCS 2006-2 to the LINE-1-RX port of the EDFA–35 card in NCS 2006 -3.
16. Connect an LC/LC fiber from the LINE-RX port of the 20-SMR-FS card (NCS 2006-2) to the LINE-1-TX port of the EDFA–35 card (NCS 2006 -3).
17. Connect an LC/LC fiber from the LINE-2-TX port of the EDFA-35 card in NCS 2006 -3 to the COM-RX port of the EDRA-2-26 card in NCS 2006 -3.
18. Connect an LC/LC fiber from the LINE-2-RX port of the EDFA-35 card (NCS 2006 -3) to the COM-TX port of the EDRA-2-26 card in NCS 2006-3.
19. Connect an LC/LC fiber from the LINE-TX port of the EDRA-2-26 card in NCS 2006-3 to the LINE-RX port of the EDRA-2-26 card in NCS 2006 -4.
20. Connect an LC/LC fiber from the LINE-RX port of the EDRA-2-26 card in NCS 2006-3 to the LINE-TX port of the EDRA-2-26 card in NCS 2006 -4.

21. Connect an LC/LC fiber from the COM-TX port of the EDRA-2-26 card in NCS 2006-4 to the COM-RX port of the EDFA-17 card in NCS 2006 -4.
22. Connect an LC/LC fiber from the COM-RX port of the EDRA-2-26 card in NCS 2006-4 to the COM-TX port of the EDFA-17 card in NCS 2006 -4.
23. Connect an LC/LC fiber from the COM-RX port of the EDRA-2-26 card (NCS 2006-4) to the COM-TX port of the EDFA-17 card in NCS 2006 -4.
24. Connect an LC/LC fiber from the LINE-TX port of the EDFA-17 card in NCS 2006-4 to the COM-RX port of the RAMAN-CTP card in NCS 2006-4.
25. Connect an LC/LC fiber from the LINE-RX port of the EDFA-17 card in NCS 2006-4 to the COM-TX port of the RAMAN-CTP card in NCS 2006-4.
26. Connect an LC/LC fiber from the LINE-TX port of the RAMAN-CTP card in NCS 2006-4 to the LINE-RX port of the RAMAN-CTP card in NCS 2006-5.
27. Connect an LC/LC fiber from the LINE-RX port of the RAMAN-CTP card in NCS 2006-4 to the LINE-TX port of the RAMAN-CTP card in NCS 2006-5.
28. Connect an LC/LC fiber from the COM-TX port of the RAMAN-CTP card in NCS 2006-5 to the LINE-RX port of the 20-SMR-FS card in NCS 2006-5.
29. Connect an LC/LC fiber from the COM-RX port of the RAMAN-CTP card in NCS 2006-5 to the LINE-TX port of the SMR20 card in NCS 2006-5.
30. Connect an LC/LC fiber from the OSC-OTDR-2 port of the TNCS-2O card in NCS 2006 -5 to the OSC-TX port of the 20-SMR-FS card in NCS 2006 -5.
31. Connect a 16MPO-MPO-2 cable from the EXP1-8 port of the 20-SMR-FS card in NCS 2006-5 to the COM port of the MF-MPO-16LC module.
32. Connect an LC/LC fiber from the LINE-TX port of the EDFA-17-1 card in NCS 2006-5 to the RX port of the MF-MPO-16LC module.
33. Connect an LC/LC fiber from the COM-RX port of the EDFA-17-2 card in NCS 2006-5 to the TX port of the MF-MPO-16LC module.
34. Connect an LC/LC fiber from the COM-RX port of the EDFA17-1 card in NCS 2006-5 to the COM-TX port of the MD-64-2 module.
35. Connect an LC/LC fiber from the LINE-TX port of the EDFA-17-2 card in NCS 2006-5 to the COM-RX port of the MD-64-2 module.

Next steps

After you build the topology, perform these steps:

- [Import the Cisco ONP Configuration File into SVO.](#)
- [Manage Expected Input Power](#)

Components and connections in point-to-point topology with NCS 1010 nodes

Topology diagram

This topology diagram illustrates the setup for point-to-point networks using NCS 1010 nodes.

Figure 11: Point-to-point topology using NCS 1010 nodes

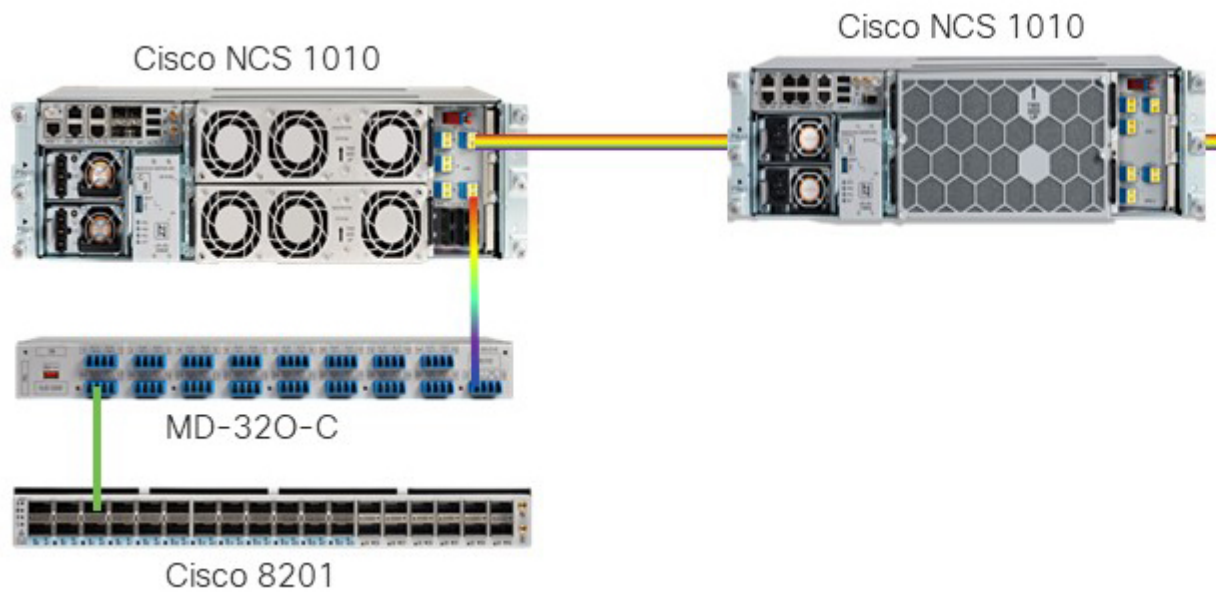

These diagrams show the wiring configuration for point-to-point topology using NCS 1010 nodes.

Figure 12: Wiring diagram for point-to-point topology

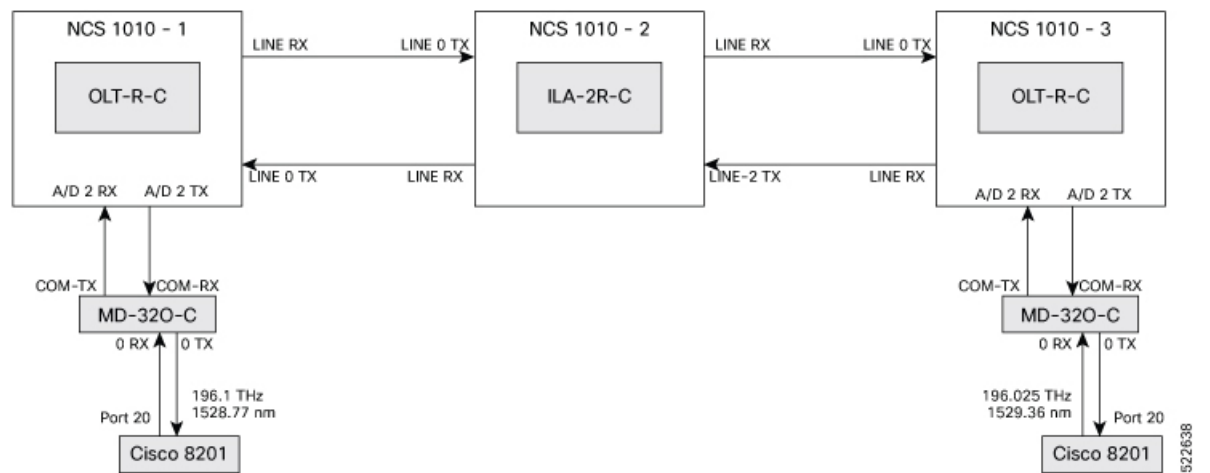

Topology components

You need this hardware to build this topology:

- Cisco NCS 1010 devices
- NCS1K-MD-32O-C modules
- QDD-400G-ZR-S transceivers
- LC/LC cables
- Cisco 8201 routers

For more information, see [Hardware components](#).

Port connections

Use this sequence to connect the cables and build this topology:

1. On the Cisco 8201 routers:
 - a. Align the QDD-400G-ZR-S transceiver module with the transceiver socket opening in Port 20. Then, carefully slide the transceiver into the socket until the transceiver comes in contact with the socket electrical connector.
 - b. Holding the pull-tab, seat the transceiver in the module's transceiver socket fully until it clicks.
 - c. Attach an LC/LC fiber immediately to the QDD-400G-ZR-S transceiver module.
 - d. Connect the other end of the LC/LC fiber to the corresponding bulkhead adapter on the front panel of the NCS1K-MD-32O-C (MD-32-O-C) module. In this sample topology, we use a frequency of 196.1 THz (1528.77 nm).
2. Connect an LC/LC fiber from the COM-TX port of the MD-32-O-C module to the A/D 2 RX port of the OLT-R-C module in NCS 1010-1.
3. Connect an LC/LC fiber from the COM-RX port of the MD-32-O-C module to the A/D 2 TX port of the OLT-R-C module in NCS 1010-1.
4. Connect an LC/LC fiber from the LINE RX port of the OLT-R-C module in NCS 1010-1 to the LINE 0 TX port of the ILA-2R-C module in NCS 1010-2.
5. Connect an LC/LC fiber from the LINE-0 TX port of the OLT-R-C module in NCS 1010-1 to the LINE 0 LINE RX port of the ILA-2R-C module in NCS 1010-2.
6. Connect an LC/LC fiber from the LINE 2 LINE RX port of the ILA-2R-C module in NCS 1010-2 to the LINE 0 TX port of the OLT-R-C module in NCS 1010-3.
7. Connect an LC/LC fiber from the LINE-2 TX port of the ILA-2R-C module in NCS 1010-2 to the LINE RX port of the OLT-R-C module in NCS 1010-3.
8. Connect an LC/LC fiber from the A/D 2 RX port of the OLT-R-C module in NCS 1010-3 to the COM-TX port of the MD-32-O-C module.
9. Connect an LC/LC fiber from the A/D 2 TX port of the OLT-R-C module in NCS 1010-3 to the COM-RX port of the MD-32-O-C module.

Next steps

After you build the topology, perform these steps:

- [Import the Cisco ONP Configuration File into SVO.](#)
- [Manage Expected Input Power](#)

Components and connections in multi-degree topology with NCS 1010 nodes

Topology diagram

This topology diagram illustrates the setup for multi-degree networks using NCS 1010 nodes.

Figure 13: Multi-degree topology using NCS 1010 nodes

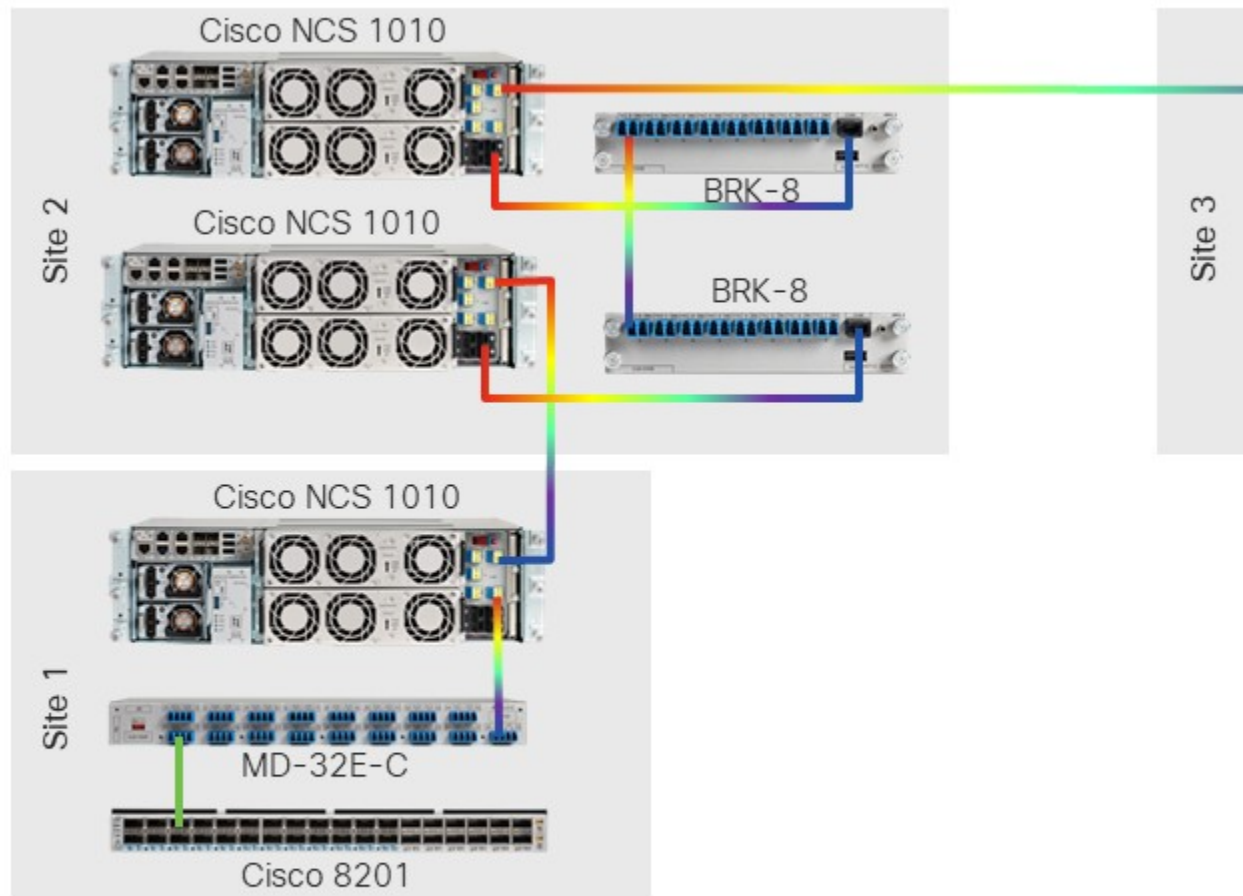

© 2020 Cisco and/or its affiliates. All rights reserved. Cisco Confidential

These diagrams show the wiring configuration for the multi-degree topology using NCS 1010 nodes.

Figure 14: Wiring diagram for multi-degree topology

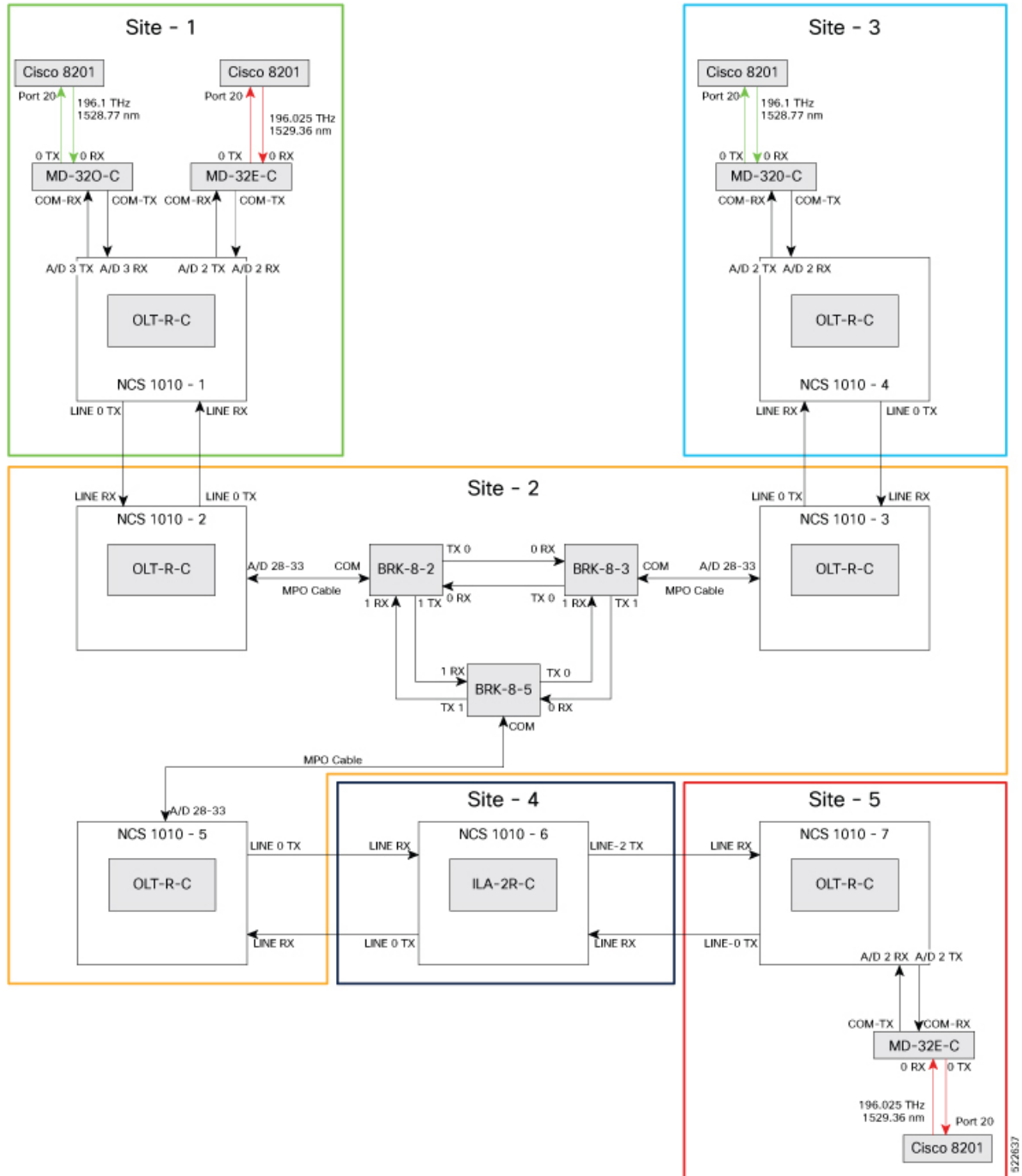

Topology components

You need this hardware to build this topology:

- Cisco NCS 1010 devices
- NCS1K-MD32E-C modules

- NCS1K-MD32O-C modules
- NCS1K-BRK-8 modules
- Cisco 8201 routers
- QDD-400G-ZR-S transceivers
- LC/LC cables
- MPO cables

For more information, see [Hardware components](#).

Port connections

Use this sequence to connect the cables and build this topology:

1. On the Cisco 8201 routers:
 - a. Align the QDD-400G-ZR-S transceiver module with the transceiver socket opening in Port 20. Carefully slide it into the socket until contact with the socket electrical connector.
 - b. Holding the pull-tab, seat the transceiver in the module's transceiver socket fully until it clicks.
 - c. Attach an LC/LC fiber immediately to the QDD-400G-ZR-S transceiver module.
 - d. Connect the other end of the LC/LC fiber to the corresponding bulkhead adapter on the front panel of the NCS1K-MD-32O-C (MD-32-O-C using frequency 196.1 THz) module or the NCS1K-MD-32E-C (MD-32-E-C using frequency 195.025 THz) module.
2. Connect an LC/LC fiber from the COM-TX port of the MD-32-O-C module to the A/D 3 RX port of the OLT-R-C module in NCS 1010-1.
3. Connect an LC/LC fiber from the COM-RX port of the MD-32-O-C module to the A/D 3 TX port of the OLT-R-C module in NCS 1010-1.
4. Connect an LC/LC fiber from the COM-TX port of the MD-32-E-C module to the A/D 2 RX port of the OLT-R-C module in NCS 1010-1.
5. Connect an LC/LC fiber from the COM-RX port of the MD-32-E-C module to the A/D 2 TX port of the OLT-R-C module in NCS 1010-1.
6. Connect an LC/LC fiber from the LINE RX port of the OLT-R-C module in NCS 1010-1 to the LINE 0 TX port of the OLT-R-C module in NCS 1010-2.
7. Connect an LC/LC fiber from the LINE 0 TX port of the OLT-R-C module in NCS 1010-1 to the LINE RX port of the OLT-R-C module in NCS 1010-2.
8. Connect an MPO fiber from the A/D 4-11 port of the OLT-R-C module in NCS 1010-2 to the COM port of the BRK-8-2 module.
9. Using LC/LC fibers, interconnect the BRK-8-2, BRK-8-3, and BRK-8-5 modules.
10. Connect an MPO fiber from the COM port of the BRK-8-3 module to the A/D 4-11 port of the OLT-R-C module in NCS 1010-3 .
11. Connect an LC/LC fiber from the LINE RX port of the OLT-R-C module in NCS 1010-3 to the LINE 0 TX port of the OLT-R-C module in NCS 1010-4.

12. Connect an LC/LC fiber from the LINE 0 TX port of the OLT-R-C module in NCS 1010-3 to the LINE RX port of the OLT-R-C module in NCS 1010-4.
13. Connect an LC/LC fiber from the COM-TX port of the MD-32-O-C module to the A/D 2 RX port of the OLT-R-C module in NCS 1010-4.
14. Connect an LC/LC fiber from the COM-RX port of the MD-32-O-C module to the A/D 2 TX port of the OLT-R-C module in NCS 1010-4.
15. Connect an MPO fiber from the COM port of the BRK-8-5 module to the A/D 4-11 port of the OLT-R-C module in NCS 1010-5 .
16. Connect an LC/LC fiber from the LINE 0 TX port of the OLT-R-C module in NCS 1010-5 to the LINE 0 LINE RX port of the ILA-2R-C module in NCS 1010-6.
17. Connect an LC/LC fiber from the LINE RX port of the OLT-R-C module in NCS 1010-5 to the LINE 0 TX port of the ILA-2R-C module in NCS 1010-6.
18. Connect an LC/LC fiber from the LINE-2 TX port of the ILA-2R-C module in NCS 1010-6 to the LINE RX port of the OLT-R-C module in NCS 1010-7.
19. Connect an LC/LC fiber from the LINE 2 LINE RX port of the ILA-2R-C module in NCS 1010-6 to the LINE 0 TX port of the OLT-R-C module in NCS 1010-7.
20. Connect an LC/LC fiber from the COM-TX port of the MD-32-E-C module to the A/D 2 RX port of the OLT-R-C module in NCS 1010-7.
21. Connect an LC/LC fiber from the COM-RX port of the MD-32-E-C module to the A/D 2 TX port of the OLT-R-C module in NCS 1010-7.

Next steps

After you build the topology, perform these steps:

- [Import the Cisco ONP Configuration File into SVO.](#)
- [Manage Expected Input Power](#)