



Cisco NCS 1010 Optical Line System - An Overview

This chapter provides an overview for NCS 1010 line system.

- [NCS 1010 Chassis and Line Cards](#), on page 1
- [Cisco NCS 1000 Passive Modules](#), on page 4
- [Document Objective](#), on page 6
- [Document Organization](#), on page 6

NCS 1010 Chassis and Line Cards

Cisco NCS 1010 is a next-generation optical line system optimized for ZR/ZR+ WDM router interfaces. Its salient features are:

- Provides point-to-point connectivity between routers with WDM interfaces.
- Multiplexes the signals received from multiple routers over a single fiber.
- With one MPO port, it can be scaled to 8 Degree.
- Caters to C-band WDM transmission to maximize capacity, and can be enhanced to C+L combined band in the future.

Cisco NCS 1010 is a 3RU chassis that has an in-built External Interface Timing Unit (EITU) and the following field-replaceable modules.

- Controller
- Two power supply units
- Two fan trays
- Fan filter
- Line card

See [Hardware Installation Guide for Cisco NCS 1010 and Cisco NCS 1000 Passive Modules](#) for more detailed images.

Line Cards

There are five different variants of the line card:

- OLT-C Line Card: C-band Optical Line Terminal without Raman
- OLT-R-C Line Card: C-band Optical Line Terminal with Raman
- ILA-C Line Card: C-band In-Line Amplifier without Raman
- ILA-R-C Line Card: C-band In-Line Amplifier with one side Raman
- ILA-2R-C Line Card: C-band In-Line Amplifier with both sides Raman

OLT-C Line Card

The C-band Optical Line Terminal without Raman (OLT-C) line card includes the following features:

- 25-dBm line preamplifier True Variable Gain (TVG) Erbium-Doped Fiber Amplifier (EDFA) with two switchable gain ranges
- Dedicated amplification of the odd and even add channels through an embedded Fixed Gain (FG) EDFA
- 23-dBm line boost-amplifier TVG EDFA single gain range
- Dedicated EDFA for noise loading
- Embedded Optical Time Domain Reflectometer (OTDR) for line RX and TX monitoring
- 37 ports Optical Channel Monitoring (OCM)
- Dedicated Tunable Laser (TL) enabling Connection Verification (CV) and patch cord discovery features
- Up to 30 EXP ports
- Embedded Optical Service Channel at Fast Ethernet (FE)
- Multiplexing and demultiplexing of odd and even channels
- C+L combiner for multiplexing and demultiplexing L-band channels
- 2x2 switch to reverse transmit direction of Optical Service Channel (OSC)-C
- Fiber reflectors to support fiber end detection by OTDR

OLT-R-C Line Card

The C-band Optical Line Terminal with Raman (OLT-R-C) line card includes the features of the OLT-C line card along with the Raman amplifier.

The following are the features of the Raman amplifier:

- Five different pump wavelengths for supporting C+L Raman amplification
- Embedded Distributed Feedback (DFB) laser at 1568.77 nm (class 1M) to be used for optical safety (link continuity)
- Full monitoring of pumps, DFB laser and signal power
- Raman pump back-reflection detector

- Meets class 1M Laser safety.
- Additional Photodiode (PD) to monitor remnant pump power at the far end

ILA-C Line Card

The C-band In Line Amplifier without Raman (ILA-C) line card includes the following features:

- Two independent TVG EDFA block, covering full operative gain ranging 8–36 dB
- Each EDFA block can provide up to 23 dBm output power
- Dynamic Gain Equalization (DGE) embedded capability to compensate for line tilt and ripple
- Embedded OTDR for line1/2-RX/TX monitoring
- Four-ports OCM for channels monitoring
- Embedded Optical Service Channel at Fast Ethernet (FE)
- C+L combiner for multiplexing/demultiplexing L-band channels
- Dedicated ports for amplifiers output monitoring
- 2x2 switch to reverse transmit direction of OSC-C for both directions
- Fiber reflectors to support fiber end detection by OTDR

The following image displays the port connection between the ILA-C line card and OLT-C line cards.

Figure 1: ILA-C Line Card Port Connection

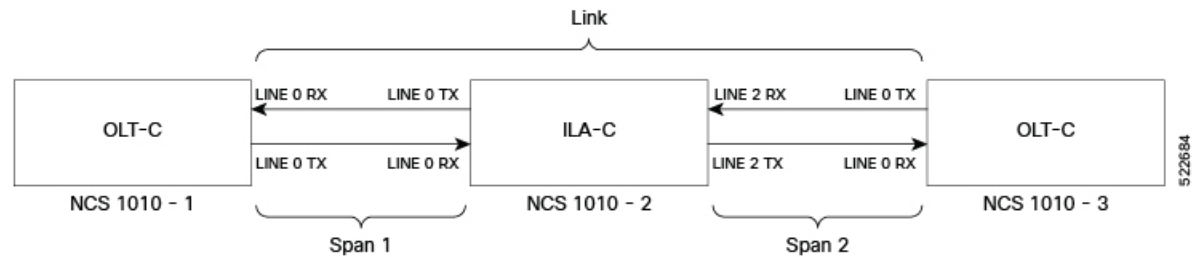

ILA-R-C Line Card

The C-band In Line Amplifier with Raman (ILA-R-C) line card includes the features of ILA-C and Raman amplifier.

ILA-2R-C Line Card

The C-band In-Line Amplifier with two Raman (ILA-2R-C) line card includes the features of the ILA-C and Raman amplifier on both directions.

External Interface Timing Unit

The External Interface Timing Unit (EITU) manages the control plane interfaces and includes all user external interfaces (timing and management). It is connected to the controller with a redundant 10G Ethernet bus.

The following is the list of the available user interfaces:

- Coaxial connector for GPS antenna RF input (with +5V antenna power, if necessary)
- Console/Universal Asynchronous Receiver/Transmitter (UART) Interface (1x)
- Two Small Form-Factor Pluggables (SFP) for 1GE optical PTP port (1588 and SyncE)
- Two SFPs for 1GE optical User Data Channels (UDC)
- Three USB 2.0 type A, 1.8A max @5V/12V (with Cisco NCS 1000 Breakout Patch Panel support)
- Coaxial connector for 10MHz sync signal (bidirectional)
- Coaxial connector for 1PPS sync signal (bidirectional)
- RJ45 for 1588 TOD (1x)
- Three 10/100/1000 RJ-45 Ethernet management ports and Interconnection Link (ILINK)

Cisco NCS 1000 Passive Modules

The Cisco NCS 1000 passive modules power the Cisco NCS 1010 chassis to offer an optical line system solution. The passive modules enable the NCS 1010 chassis to implement long-haul and metro topologies. The Cisco NCS 1010 supports the following passive modules:

Cisco NCS 1000 Breakout Patch Panel

Cisco NCS 1000 Breakout Patch Panel is colorless breakout-modular patch panel. It is powered by the NCS 1010 chassis using a single USB 2.0 cable from the NCS 1010 EITU. The breakout panel contains four USB 2.0 connections that power the breakout modules. It allows connections between the OLT-C and OLT-R-C line cards that are installed in the NCS 1010 chassis and the four breakout modules using MPO cables. The breakout panel supports up to 72 colorless Mux/Demux channels and 8-directional interconnections. The breakout panel is 4 RU high and has adjustable fiber guides for fiber routing. The empty slots are covered with dummy covers. The panel is shipped with USB 2.0 connectors that are connected to the corresponding dummy covers. The plastic transparent cover can be installed in front of the panel for fiber protection. The panel is designed to fit a 19-inch rack. The panel can also be installed on ETSI and 23-inch rack using adapter brackets.

The breakout panel supports the following breakout modules:

NCS1K-BRK-8

The NCS1K-BRK-8 module provides the breakout of 16 fibers from an MPO-24 connector to 8 duplex line card connectors. It essentially performs an optical connection adaptation of MPO-to-LC connectors for the ADD/DROP signals of the MPO ports of OLT line cards. For each port (MPO and LC), power monitors with tone detection capability are available. A filtered optical loopback (191.175 THz) from one MPO input port (fiber-1) to all MPO output ports is available for connection verification.

The following image displays the port connection between BRK-8 and OLT-C cards.

Figure 2: BRK-8 Panel Port Connection with OLT-C Cards

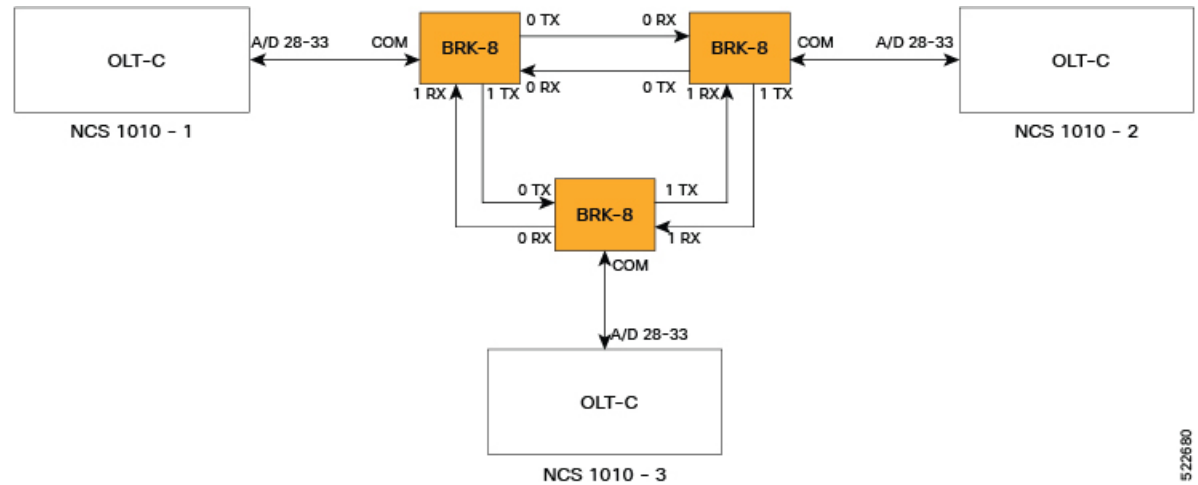

522680

NCS1K-BRK-24

The NCS1K-BRK-24 module provides the breakout of 16 fibers from an MPO-24 connector to 24 duplex LC connectors. The signals on each fiber from the MPO input ports are split over three LC output ports by a 1x3 optical splitter. The signals from the three adjacent input LC ports are combined into a single MPO fiber output port through a 1x3 optical coupler. For each port (MPO and LC), power monitors with tone detection capability are available. A filtered optical loopback (191.175 THz) from one MPO input port (fiber-1) to all MPO output ports is available for connection verification.

The following image displays port connections between BRK-24 panel and NCS 1010 and NCS 1004 chassis.

Figure 3: Port Connections Between BRK-24 Panel and NCS 1010 and NCS 1004 Chassis

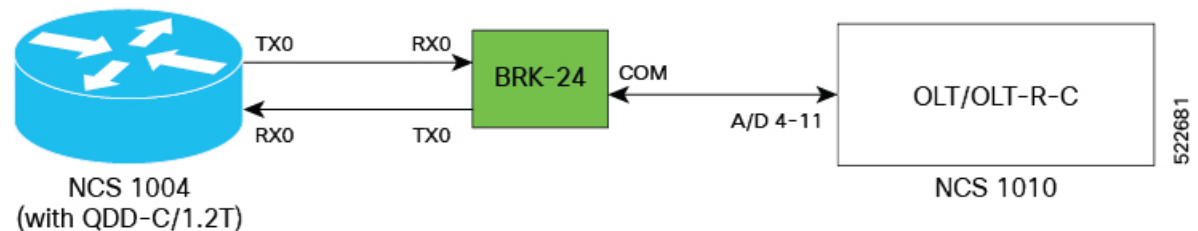

522681

Cisco NCS 1000 32-Channel Mux/Demux Patch Panels

The Cisco NCS 1000 32-Channel Mux/Demux patch panels are a pair of passive Athermal Arrayed Waveguide Grating (AAWG) based modules (PIDs NCS1K-MD-32O-C and NCS1K-MD-32E-C). Each Mux/Demux panel has 32 channels and works as an add/drop unit for the OLT-C and OLT-R-C line cards. Each Mux/Demux panel allows the multiplexing and demultiplexing of 32 channels with 150-GHz spacing. 75-GHz frequency shift exists between the ODD and EVEN panels. When both panels are used on the same OLT (OLT-C and OLT-R-C) line cards, the combined capacity becomes 64 channels with 75-GHz spacing. Each Mux/Demux panel provides a wide optical pass-band support. When used as a standalone, each panel acts as an add/drop unit for 32 channels at 140 GbD.

The NCS1K-MD-32O/E-C panel operates in C-band.

The Cisco NCS 1000 Mux/Demux patch panels are fully passive. The units are powered with a USB 2.0 connection in the NCS 1010 chassis. The panels are capable of monitoring channel power, verifying connection, detecting tone, and reporting the inventory data.

The following image displays the port connection between the Mux/Demux panels and NCS 1010 and routers.

Figure 4: Port Connection between the Mux/Demux Panels and NCS 1010 and Routers

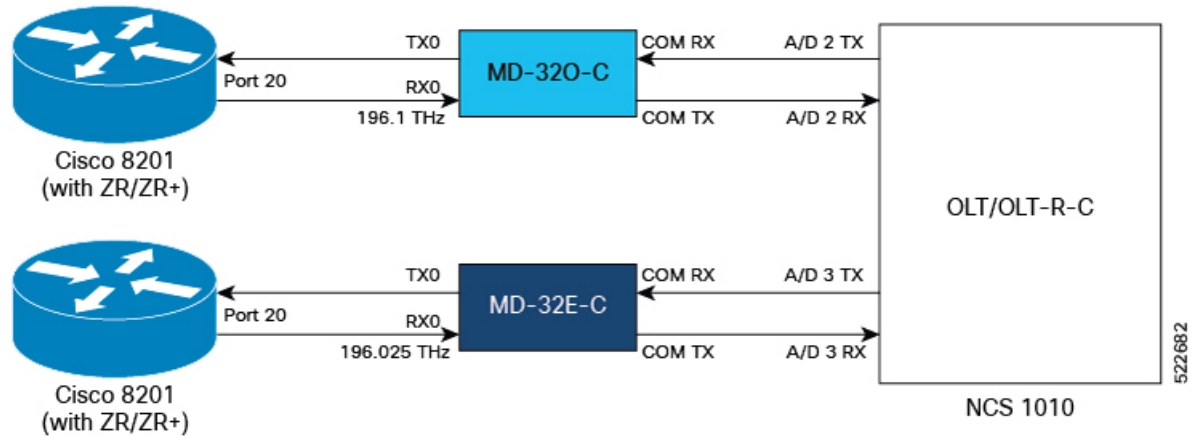

Document Objective

Cisco Network Convergence System (NCS) 1010 platform has the following configuration guides.

- The *Cisco NCS 1010 System Setup and Software Installation Guide* describes how to bring up the NCS 1010 system and perform the required software installation.
- The *Cisco NCS 1010 Datapath Configuration Guide* describes how to configure various datapaths on NCS 1010.
- The *Cisco NCS 1010 Optical Applications Configuration Guide* describes multiple optical applications on NCS 1010, that help to bring up the link and maintain traffic on the link.

Document Organization

This document is organized into the following chapters:

Chapter	Description
Bring-up Cisco NCS 1010	Various methods such as iPXE, Zero Touch Provisioning, and USB drive to boot up the Cisco NCS 1010 system .
Disaster Recovery	The disaster recovery process and the health check of backup ISO image.

Chapter	Description
Perform Preliminary Checks	Preliminary checks to be performed after successfully logging into the console and the suggested corrective actions if any setup issue is detected.
Upgrade Software and FPD	Procedures to upgrade the Cisco IOS XR software and FPDs.
Remote Node Management in NCS 1010	Manage an ILA node remotely in NCS 1010.

