



Connecting Power and Ground

This chapter describes how to connect the power and ground for the NCS 2015 shelf.

The sections are:

- [Power and Ground Description, on page 1](#)
- [Cabling Guidelines for NCS 2015 DC Shelf, on page 4](#)
- [NTP-L57 Installing Power and Ground to the NCS 2015 Shelf , on page 6](#)

Power and Ground Description

Ground the equipment according to the Telcordia standards or local practices. The following sections describe power and ground for the NCS 2015 shelves.



Warning

This equipment must be grounded. Never defeat the ground conductor or operate the equipment in the absence of a suitably installed ground conductor. Contact the appropriate electrical inspection authority or an electrician if you are uncertain that suitable grounding is available. Statement 1024



Warning

This unit is intended for installation in restricted access areas. A restricted access area can be accessed only through the use of a special tool, lock and key, or other means of security. Statement 1017



Note

For detailed instructions on grounding the NCS 2015 chassis, see the [Electrostatic Discharge and Grounding Guide for Cisco NCS 2000 Series](#) .

Power and Ground

The NCS 2015 has redundant AC and DC power modules.

For redundant AC power feeds, install the four AC power modules, and use the four power cables (right and left cables) and one ground cable.



Note The ground lug of the NCS 2015 AC shelf must be permanently connected to ground. The single ground lug must be a dual-hole type, UL Listed, CSA certified and rated to accept the #4 AWG cable. The grounding lug must be assembled on the chassis with two screws and washers.

For the NCS 2015 AC shelf:

- The building installation must provide a means for connection to protective earthing.
- The equipment must be soundly earthed.
- Service personnel must check whether the socket outlet from which the equipment is to be powered provides a connection to the building's protective earthing. If there is no connection, the service personnel must arrange for the installation of a protective earthing conductor from a separate earthing terminal to the protective earthing wire in the building.

For an AC power supply, the fuse rating must not exceed 20A. For North America, the branch circuit protection must be rated 20A. The overcurrent or short circuit protection must be in accordance with local and national electrical codes. The voltage rating value for AC power ranges between 200 VAC to 240 VAC depending on the standards of various countries. This product is intended for use on the TN and TT power systems.

The CTC display of protect voltage must be ignored for NCS 2015 AC shelf.

For redundant DC power feeds, install four DC power modules and use eight power cables and one ground cable. For a single power feed, only two power cables (#6 AWG, copper conductor, 194 degrees F [90 degrees C] minimum) and one ground cable (#4 AWG) are required. Use a conductor with low impedance to ensure circuit overcurrent protection. However, the conductor must have the capability to safely conduct any faulty current that might be imposed. For a DC power supply, the fuse rating must not exceed 60 A.

The DC power modules have -48 VDC or -60 VDC #6 AWG dual-hole lug power terminals.

We recommend the following wiring conventions, but customer conventions prevail:

- Red wire for battery connections (-48 VDC or -60 VDC).
- Black wire for battery return connections (RET).
- The battery return connection is treated as DC-I, as defined in Telcordia GR-1089-CORE, Issue 6.

The single ground lug must be a dual-hole type, UL Listed, CSA certified and rated to accept the #4 AWG cable. The grounding lug must be assembled on the chassis with two screws and washers. (See the figure below).

Figure 1: Ground Lug on the NCS 2015 DC Shelf

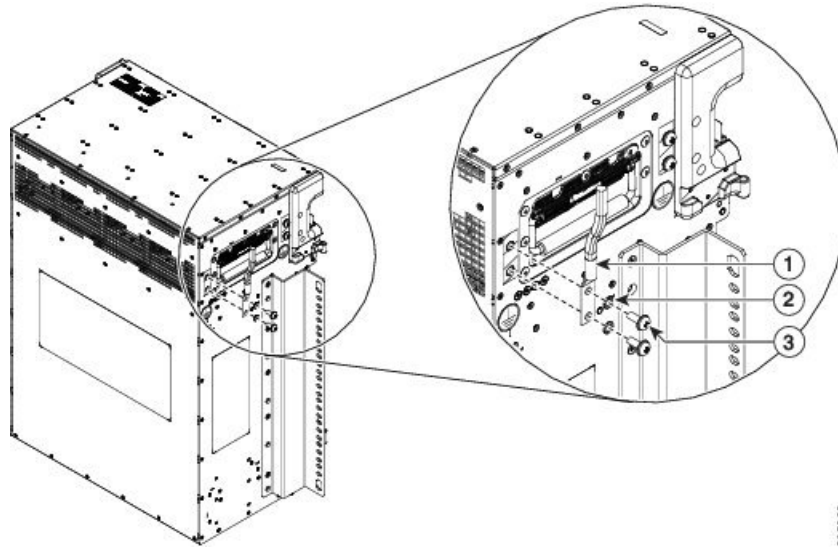

1	Ground lug	2	Washer
3	Screw		

The rating labels are shown in the figures below

Figure 2: Rating Label for NCS 2015 AC Chassis



Figure 3: Rating Label for NCS 2015 DC Chassis



Cabling Guidelines for NCS 2015 DC Shelf

The following figures display the cable distribution in the NCS 2015 DC shelf. It is recommended to use the 23 inch rack.

Figure 4: Cabling for NCS 2015 DC Shelf

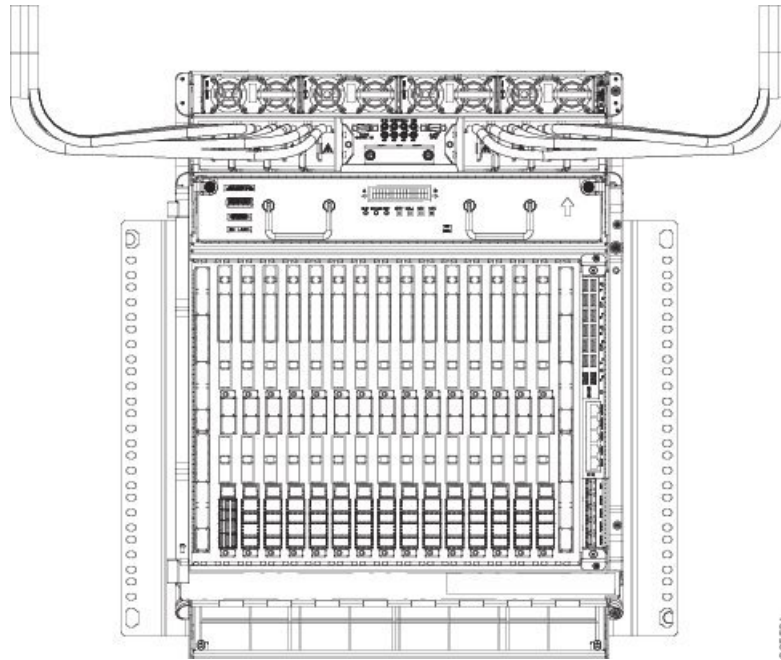
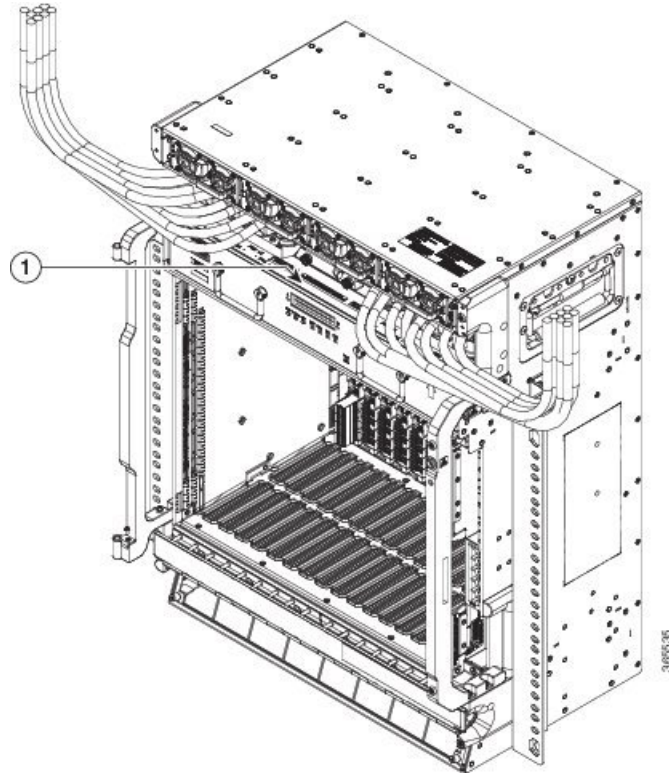

Figure 5: Cabling for NCS 2015 DC Shelf



1 Power distribution label

To install the DC distribution using the figure below:

Figure 6: Power Distribution Label - Old Version



- First, route the P1B cable to the left of the chassis against the top of the power tray.
- Second, route the P2B cable under the P1B cable.
- Third, route the P3B cable under the P2B cable.
- Fourth, route the P4B cable under the P3B cable.
- Fifth, route the P1A cable to the right of the chassis against the top of the power tray.
- Sixth, route the P2A cable under the P1A cable.
- Seventh, route the P3A cable under the P2A cable.
- Eighth, route the P4A cable under the P3A cable.

To install the DC distribution using the figure below :

Figure 7: Power Distribution Label - New Version



- First, route the P1A cable to the left of the chassis against the top of the power tray.
- Second, route the P2A cable under the P1A cable.

- Third, route the P3A cable under the P2A cable.
- Fourth, route the P4A cable under the P3A cable.
- Fifth, route the P1B cable to the right of the chassis against the top of the power tray.
- Sixth, route the P2B cable under the P1B cable.
- Seventh, route the P3B cable under the P2B cable.
- Eighth, route the P4B cable under the P3B cable.



Note This arrangement allows the management of cables within the boundaries of the chassis.



Note When transitioning to the rack, ensure that you maintain a two inch bend radius.

NTP-L57 Installing Power and Ground to the NCS 2015 Shelf

Purpose	This procedure installs power feeds and grounds the NCS 2015 system.
Tools/Equipment	<ul style="list-style-type: none"> • #2 Phillips Dynamometric screwdriver • Medium slot-head screwdriver • Small slot-head screwdriver • Screws • Ground cable 21.2-mm² (#4 AWG) stranded • Listed pressure dual-holes lugs suitable for #8 AWG copper conductors • Wire cutters • Wire strippers • Crimp tool • Fuse panel • Power cable (from fuse panel to power modules) • Two-hole grounding lug • Wire wrapper
Prerequisite Procedures	<ul style="list-style-type: none"> • NTP-L53 Installing the Power Modules in NCS 2015 Shelf. • Connect the chassis to the office ground. For detailed instructions on how to ground the chassis, see the Electrostatic Discharge and Grounding Guide for Cisco NCS 2000 Series.
Required/As Needed	Required
Onsite/Remote	Onsite
Security Level	None



Warning To ensure safety of personnel and equipment, do not connect any power cables into the power module until the module is completely installed into the chassis. Statement 389



Warning To reduce the risk of electric shock, switch on the power only after the power cord is completely installed into the power module. Statement 390



Warning Blank faceplates (filler panels) serve three important functions: they prevent exposure to hazardous voltages and currents inside the chassis; they contain electromagnetic interference (EMI) that might disrupt other equipment; and they direct the flow of cooling air through the chassis. Do not operate the system unless all cards, power modules, and faceplates are in place. Statement 261



Warning This equipment must be grounded. Never defeat the ground conductor or operate the equipment in the absence of a suitably installed ground conductor. Contact the appropriate electrical inspection authority or an electrician if you are uncertain that suitable grounding is available. Statement 1024



Warning Never install an AC power module and a DC power module in the same chassis. Statement 1050



Warning When stranded wiring is required, use approved wiring terminations, such as closed-loop or spade-type with upturned lugs. These terminations should be the appropriate size for the wires and should clamp both the insulation and conductor. Statement 1002



Warning Before performing any of the following procedures, ensure that power is removed from the DC circuit. Statement 1003



Warning Before working on a chassis or working near power supplies, unplug the power cord on AC units. Statement 246



Warning This equipment is intended to be grounded. Ensure that the host is connected to earth ground during normal use. Statement 39



Warning Use copper conductors only. Statement 1025



Warning Connect the unit only to DC power source that complies with the safety extra-low voltage (SELV) requirements in IEC 60950-1 based safety standards. Statement 1033



Warning This product requires short-circuit (overcurrent) protection, to be provided as part of the building installation. Install only in accordance with national and local wiring regulations. Statement 1045



Warning This product relies on the building's installation for short-circuit (overcurrent) protection. Ensure that the protective device is rated not greater than: 10A-20A, 100-240 VAC~. Statement 1005



Warning A readily accessible two-poled disconnect device must be incorporated in the fixed wiring. Statement 1022



Warning This unit might have more than one power supply connection; all connections must be removed to de-energize the unit. Statement 1028



Caution Always use an ESD wristband when working with a powered NCS 2015. For detailed instructions on how to wear the ESD wristband, see the [Electrostatic Discharge and Grounding Guide for Cisco NCS 2000 Series](#).

Procedure

-
- Step 1** Verify that the correct fuse and alarm panel is installed in the top mounting space.
- For a DC power supply, the fuse rating must not exceed 60 A.
 - For an AC power supply, the fuse rating must not exceed 20A. For North America, the branch circuit protection must be rated 20A. The overcurrent/short circuit protection must be in accordance with local and national electrical codes.
- Step 2** Connect the office ground to the NCS 2015 shelf. For detailed instructions on grounding, see the [Electrostatic Discharge and Grounding Guide for Cisco NCS 2000 Series](#).
- Step 3** Depending on the shelf and the power module installed, complete the necessary task:
- Step 4** Complete the [DLP-L80 Turning On and Verifying DC Office Power on the NCS 2015 Shelf, on page 14](#)
- Step 5** Continue with [NTP-L54 Installing Fan-Tray Assembly in NCS 2015 Shelf](#).
- Stop. You have completed this procedure.**
-

DLP-L81 Connecting Office Power (AC) to the NCS 2015 Shelf

Purpose	This task connects AC power to the NCS 2015 shelf.
----------------	--

Tools/Equipment	<ul style="list-style-type: none"> • #2 Phillips Dynamometric screwdriver • Medium slot-head screwdriver • Small slot-head screwdriver • Wire wrapper • Wire cutters • Wire strippers • Crimp tool • Fuse panel • Ground cable #4 AWG stranded.
Prerequisite Procedures	None
Required/As Needed	Required
Onsite/Remote	Onsite
Security Level	None



Note This product is intended for use on the TN and TT power systems.



Warning When installing or replacing the unit, the ground connection must always be made first and disconnected last. Statement 1046



Warning This equipment shall be connected to AC mains provided with a surge protective device (SPD) at the service equipment complying with NFPA 70, the National Electrical Code (NEC). Statement 7012



Caution The NCS 2015 relies on the protective devices in the building installation to protect against short circuit, overcurrent and ground faults. Ensure that the protective devices are properly rated and comply with national and local codes.



Note Not more than 7 feet (2 m) of the power supply cable should be exposed between the equipment and the fiber storage tray.



Caution When terminating the frame ground, do not use soldering lug connectors, screwless (push-in) connectors, quick connect connectors, or other friction-fit connectors.



Note If the system loses power or both the TNCS or TNCS-O cards are reset, and the system is not provisioned to get the time from a Network Time Protocol/Simple Network Time Protocol (NTP/SNTP) server, you must reset the NCS 2015 clock. After powering down, the date defaults to January 1, 1970, 00:04:15. To reset the clock, see the “NTP-G24 Set Up Name, Date, Time, and Contact Information” procedure in the “Managing the Shelf” chapter of the *Cisco NCS 2000 Series Control Card and Node Configuration Guide*. If you use the TNCS or TNCS-O cards, the system clock runs for up to three hours. In this case, no action is required.

Procedure

- Step 1** Verify that the AC power modules are installed in the four slots of NCS 2015.
- Step 2** Attach the AC power cable to the cable connector in the power input panel. (See the figure below.)

Figure 8: Connecting Office Power—AC Power Modules

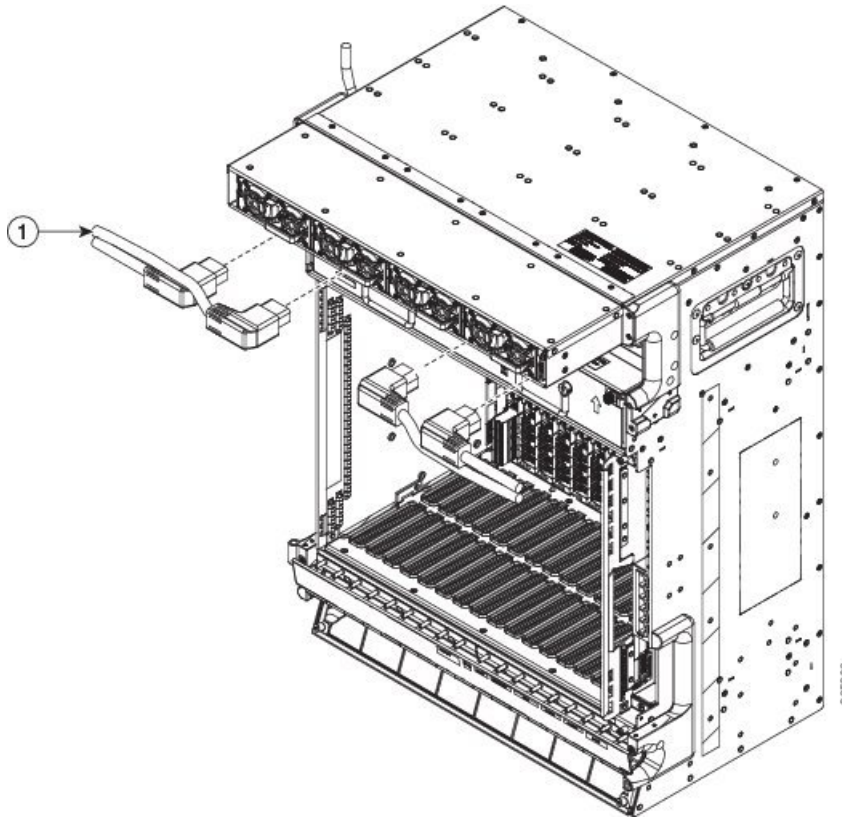

1	AC power cables
---	-----------------

- Step 3** Tighten the bail latch screws to firmly hold the AC power cable with the connector in the power in the figure below.

Figure 9: Connecting Office Power—AC Power Modules

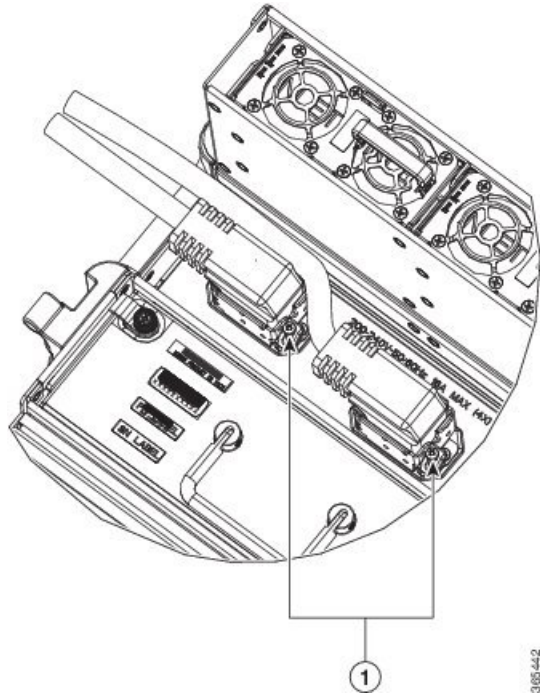

1	Bail latch screws
---	-------------------

Step 4 Connect the power cable to the fuse panel or power source.

Note

The voltage rating value for AC power ranges between 100 VAC to 240 VAC depending on the standards of various countries.

Note

Turn on the power using the power switch on the NCS 2015 shelf after installing the power cables.

Step 5 Return to your originating procedure (NTP).

Table 1: PIDs for AC Power Cables

Cable	PID
North America	CRS-AC-CAB-NA
Australia	CRS-AC-CAB-AU
EU	CRS-AC-CAB-EU

DLP-L79 Connecting Office Power (DC) to the NCS 2015 Shelf

Purpose	This task connects DC power to the NCS 2015 shelf.
Tools/Equipment	<ul style="list-style-type: none"> • #2 Phillips Dynamometric screwdriver • Medium slot-head screwdriver • Small slot-head screwdriver • Wire wrapper • Wire cutters • Wire strippers • Crimp tool • Open-end wrench or hex tube screw driver • Torque wrench • 1/4" socket wrench • Sockets • Manufacturer's die for power lug • Fuse panel • Power cable (from fuse and alarm panel to assembly), #6 AWG, copper conductors, 194 degrees F (90 degrees C) • Ground cable #4 AWG stranded • Listed pressure dual-holes lugs suitable for #6 AWG copper conductors
Prerequisite Procedures	None
Required/As Needed	Required
Onsite/Remote	Onsite
Security Level	None



Warning When installing or replacing the unit, the ground connection must always be made first and disconnected last. Statement 1046



Warning Hazardous voltage or energy may be present on DC power terminals. Always replace cover when terminals are not in service. Be sure uninsulated conductors are not accessible when cover is in place. Statement 1075



Warning To ensure that power remains off while you are performing this procedure, lock-out/tag-out the DC circuit breaker switch in the OFF (0) position until you are ready to turn it on.



Caution The NCS 2015 relies on the protective devices in the building installation to protect against short circuit, overcurrent, and ground faults. Ensure that the protective devices are properly rated and comply with national and local codes.



Note If the system loses power or both the TNCS or TNCS-O cards are reset, and the system is not provisioned to get the time from a Network Time Protocol/Simple Network Time Protocol (NTP/SNTP) server, you must reset the NCS 2015 clock. After powering down, the date defaults to January 1, 1970, 00:04:15. To reset the clock, see the “NTP-G24 Set Up Name, Date, Time, and Contact Information” procedure of the “Managing the Shelf” chapter in the *Cisco NCS 2000 Series Control Card and Node Configuration Guide*. If you use the TNCS or TNCS-O cards, the system clock runs for up to three hours. In this case, no action would be required.



Note Follow your local practices and requirements when installing power.

Procedure

-
- Step 1** Verify that the correct fuse and alarm panel is installed.
 - Step 2** Connect each of the distribution cables according to the fuse panel engineering specifications.
 - Step 3** Measure and cut the cables as needed to reach the NCS 2015 from the fuse panel.
 - Step 4** Strip 1/2 inch (12.7 mm) of insulation from all power cables that you will use.
 - Step 5** Crimp the lugs onto the ends of all the power distribution cables using the manufacturer’s suggested die for the lug.
 - Step 6** Remove the terminal block protective covers from the power distribution lugs.

Figure 10: Connecting Office Power—DC Power Modules

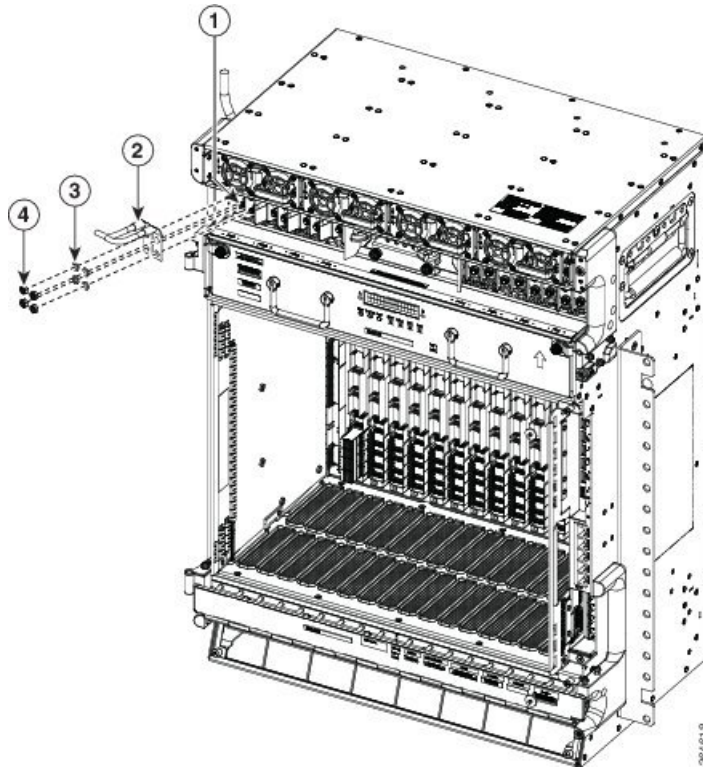

1	Terminal block	2	Power lug
3	Lock washers	4	Nuts

Step 7 Unscrew the nuts from the terminal block.

Step 8 Insert the lugs as shown in the figure above. Follow the fuse assignments to ensure the correct cabling of the battery and return to the shelf.

Note

The power lugs must be crimped horizontally with the power cables.

Step 9 Insert the lock washers and nuts to the terminal block (see the figure above). Tighten the nuts to a torque value of 20 in-lb (2.25 N-m).

Step 10 Reinstall the terminal block protective covers over the DC distribution lugs.

Step 11 Install the DC power modules in the NCS 2015 shelf.

Step 12 Return to your originating procedure (NTP).

DLP-L80 Turning On and Verifying DC Office Power on the NCS 2015 Shelf

Purpose	This task turns on the power and verifies correct power and returns on the NCS 2015 shelf.
----------------	--

Tools/Equipment	Voltmeter
Prerequisite Procedures	DLP-L79 Connecting Office Power (DC) to the NCS 2015 Shelf, on page 12
Required/As Needed	Required
Onsite/Remote	Onsite
Security Level	None



Caution Do not apply power to the shelf until you complete all the installation steps.



Warning To ensure safety of personnel and equipment, do not connect any power cables into the power module until the module is completely installed into the chassis. Statement 389



Warning To reduce the risk of electric shock, switch on the power only after the power cord is completely installed into the power module. Statement 390

Procedure

- Step 1** Using a voltmeter, verify the office battery and return at the following points on the fuse and alarm panel:
- To verify the power, place the black test lead of the voltmeter to the frame ground. Place the red test lead on the A-side connection and verify that it is between -40.5 VDC and -72.0 VDC. Place the red test lead on the B-side connection and verify that it is between -40.5 VDC and -72.0 VDC.
- Note**
For nominal steady state voltage of -48 VDC, the operating voltage range for the chassis is -40.5 VDC (minimum) to -57.6 VDC (maximum). For nominal steady state voltage of -60 VDC, the operating voltage range for the chassis is -50.0 VDC (minimum) to -72.0 VDC (maximum).
- To verify the ground, place the black test lead of the voltmeter to the frame ground. Place the red test lead on the A-side return ground and verify that no voltage is present. Place the red test lead on the B-side return ground and verify that no voltage is present.
- Step 2** To power up the shelf, insert the fuse into the fuse position according to site practice. The fuse rating must not exceed 60 A.
- Step 3** Using a voltmeter, verify the NCS 2015 shelf for -48 VDC or -60 VDC battery and return:
- To verify the A-side of the shelf, place the black lead of the voltmeter to the frame ground. Place the red test lead to the -48 V or -60 V (A-side battery connection) red cable. Verify that it reads between -40.5 VDC and -72.0 VDC. Then place the red test lead of the voltmeter to the RET1 (A-side return ground) black cable and verify that no voltage is present.

Note

For nominal steady state voltage of -48 VDC, the operating voltage range for the chassis is -40.5 VDC (minimum) to -57.6 VDC (maximum). For nominal steady state voltage of -60 VDC, the operating voltage range for the chassis is -50.0 VDC (minimum) to -72.0 VDC (maximum).

- b) To verify the B-side of the shelf, place the black test lead of the voltmeter to the frame ground. Place the red test lead to the -48 V (B-side battery connection) red cable. Verify that it reads between -40.5 VDC and -72.0 VDC. Then place the red test lead of the voltmeter to the RET2 (B-side return ground) black cable and verify that no voltage is present.

Note

If the NCS 2015 shelf is being powered at -60 VDC nominal voltage, the door must be kept closed during regular operations.

Step 4 Repeat Steps 2 and 3 for each power module that is to be powered up.

Step 5 Set the power switch to ON position after lifting its cover. The power switch is present at the top right corner of the chassis, next to the power modules. See the figure below.

Figure 11: Power Switch on the NCS 2015 Shelf

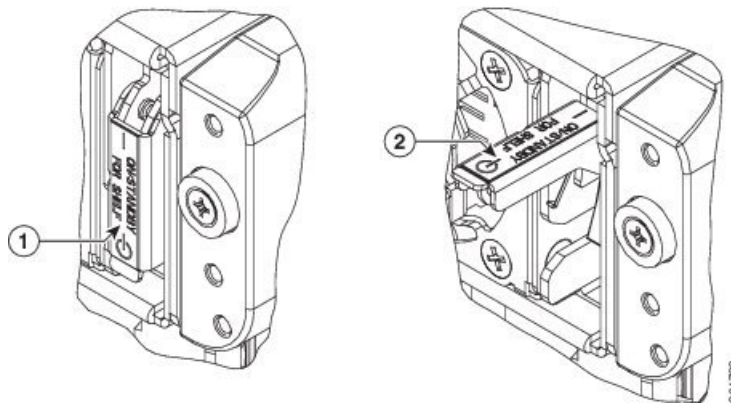

1	Cover on the power switch	2	Cover lifted to access the power switch
---	---------------------------	---	---

Step 6 Return to your originating procedure (NTP).