



Installing the Cisco NCS 2015 Door and Other Modules

This chapter describes how to install the NCS 2015 door and other modules.

The sections are:

- [Front Door, on page 1](#)
- [NTP-L67 Installing Fiber Tray of NCS 2015 Shelf , on page 2](#)
- [NTP-L50 Installing Standard Door of NCS 2015 Shelf , on page 5](#)
- [NTP-L61 Installing Deep Door of NCS 2015 Shelf , on page 9](#)
- [NTP-L51 Opening and Removing the Door of the NCS 2015 Shelf , on page 14](#)
- [External Connection Units, on page 15](#)
- [NTP-L52 Install NCS 2015 ECU Module, on page 17](#)
- [Power Modules, on page 19](#)
- [NTP-L53 Installing the Power Modules in NCS 2015 Shelf , on page 21](#)
- [LCD Unit, on page 24](#)
- [Fan-Tray Assembly , on page 24](#)
- [NTP-L54 Installing Fan-Tray Assembly in NCS 2015 Shelf, on page 25](#)
- [Air Filter , on page 28](#)

Front Door

The front door of NCS 2015 provides access to the shelf, fiber-routing tray, fan-tray assembly, and LCD screen.

There are two types of front doors that act as protective panels—standard door and deep door. The deep door provides additional space in front of the shelf to accommodate cables that do not fit inside the standard door. The deep door has a hinge and can be rotated like the standard door.

The laser warning label is placed on the rear of the chassis.

The following figure shows the NCS 2015 laser warning.

Figure 1: Laser Warning on the NCS 2015



364676

NTP-L67 Installing Fiber Tray of NCS 2015 Shelf

Purpose	This procedure installs the standard or extended fiber tray of the NCS 2015 shelf.
Tools/Equipment	#2 Phillips Dynamometric screwdriver
Prerequisite Procedures	None
Required/As Needed	As needed
Onsite/Remote	Onsite
Security Level	None



Note The standard fiber tray is included in the standard door PID and the extended fiber tray is included in the deep door PID.

Procedure

- Step 1** Align the fiber tray screw holes against the shelf screw holes.
- Step 2** Insert the M3 x 10 mm screws (one screw on each side and tighten them to a torque value of 11.5 in-lb (1.3 N-m). See figures below.
- Step 3** Insert the M3 x 8mm screws (two screws on the bottom of the fiber tray) and tighten them to a torque value of 11.5 in-lb (1.3 N-m). See figures below.

Figure 2: Installing the Standard Fiber Tray

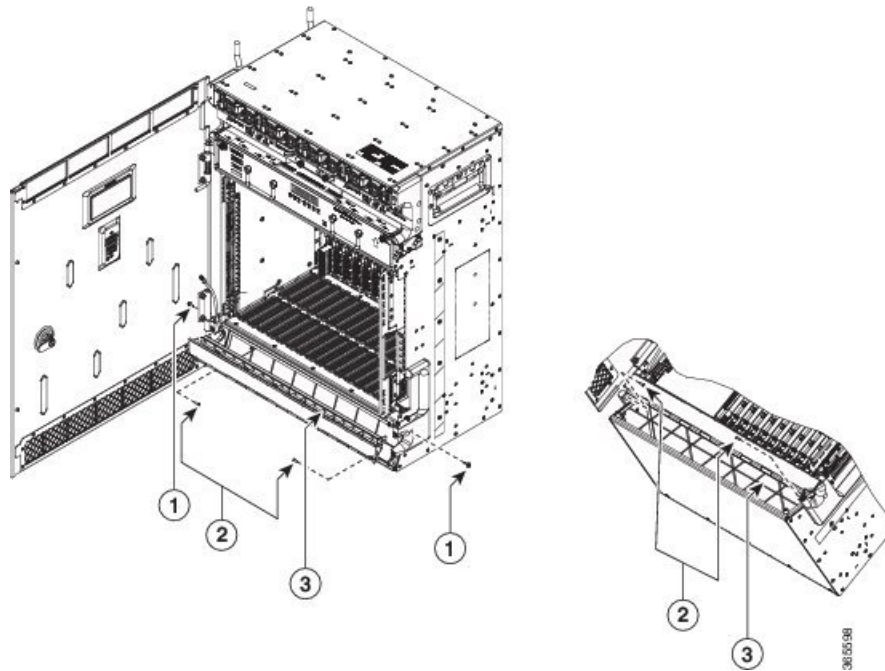

1	M3 x 10 mm screws	2	M3 x 8 mm screws
3	Standard fiber tray		

Figure 3: Installing the Extended Fiber Tray

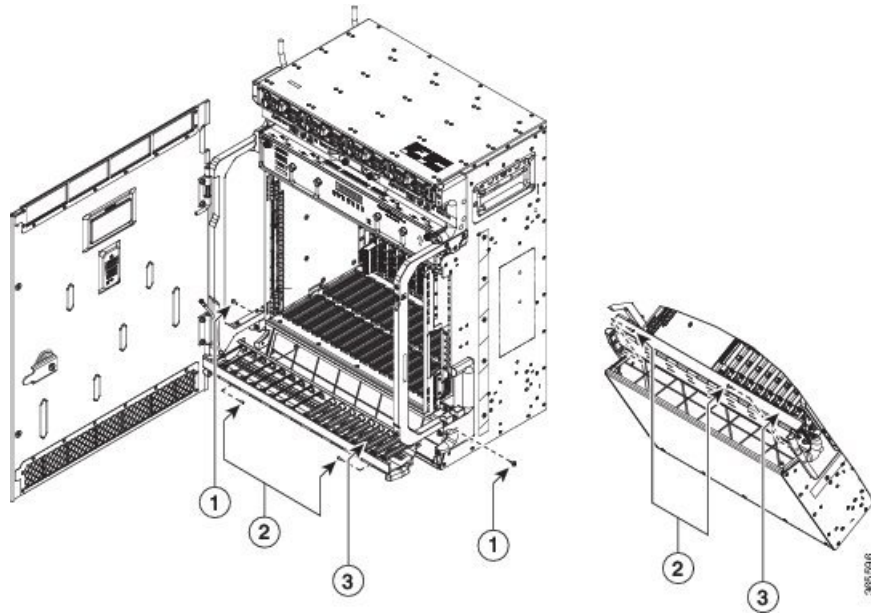

1	M3 x10 mm screws	2	M3 x8 mm screws
3	Extended fiber tray		

The installed fiber tray is shown in the figures below.

Figure 4: Installed Standard Fiber Tray

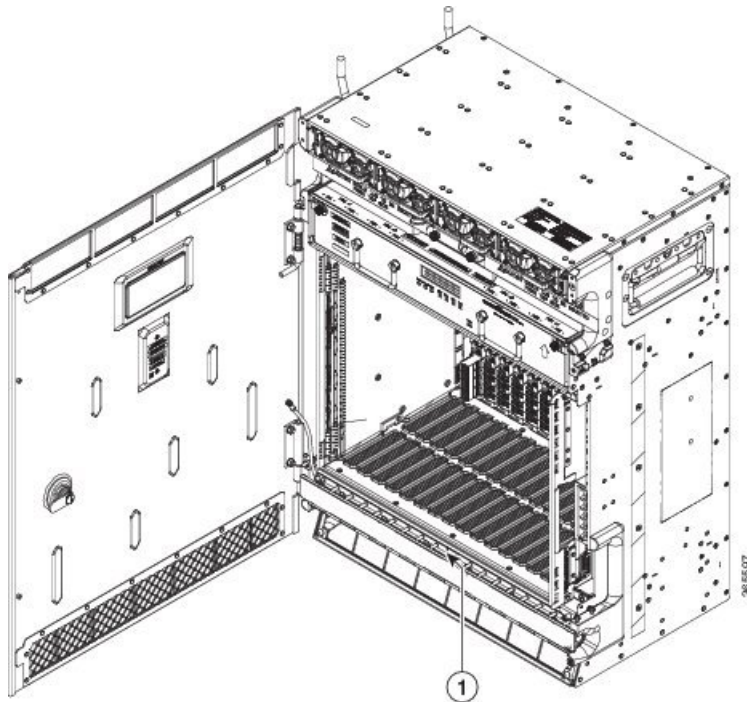

1	Standard fiber tray
---	---------------------

Figure 5: Installed Extended Fiber Tray

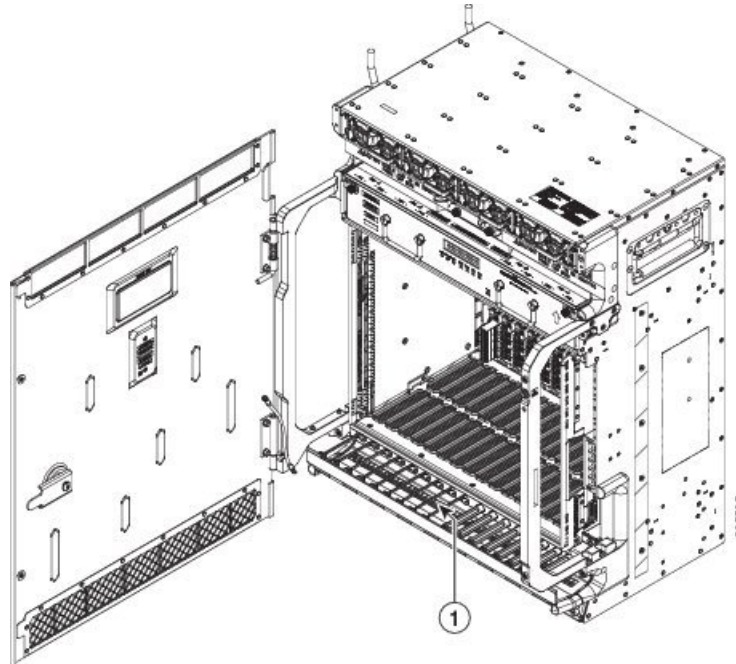

1	Extended fiber tray
---	---------------------

Stop. You have completed this procedure.

NTP-L50 Installing Standard Door of NCS 2015 Shelf

Purpose	This procedure installs the standard door of the NCS 2015 shelf.
Tools/Equipment	#2 Phillips Dynamometric screwdriver
Prerequisite Procedures	<ul style="list-style-type: none"> • NTP-L48 Mounting Brackets on NCS 2015 Shelf for ANSI Rack Configuration • Connect the chassis to the office ground. For detailed instructions on how to ground the chassis, refer to the Electrostatic Discharge and Grounding Guide for Cisco NCS 2000 Series. • NTP-L52 Install NCS 2015 ECU Module, on page 17 • NTP-L57 Installing Power and Ground to the NCS 2015 Shelf • NTP-L54 Installing Fan-Tray Assembly in NCS 2015 Shelf, on page 25 • NTP-L67 Installing Fiber Tray of NCS 2015 Shelf, on page 2
Required/As Needed	As needed

Onsite/Remote	Onsite
Security Level	None

Procedure

Step 1 Pull the top hinge pin down on the standard door.

Note

The bottom hinge pin is fixed.

Step 2 Align the standard door hinges with the chassis hinges (see the figure below).

Figure 6: Installing the Standard Door of NCS 2015 DC Shelf

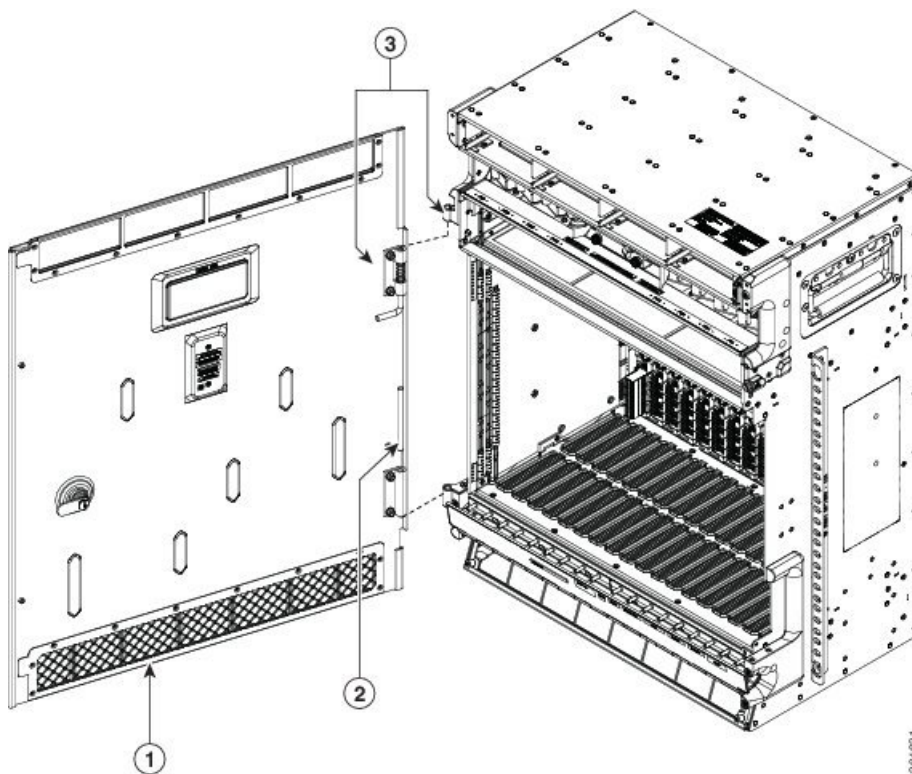

1	Standard door	2	Hinge pin
3	Align door hinge with the chassis hinge		

Step 3 Slide the bottom hinge pin into the chassis hinge and move the top hinge pin in the upward direction (see the figure below).

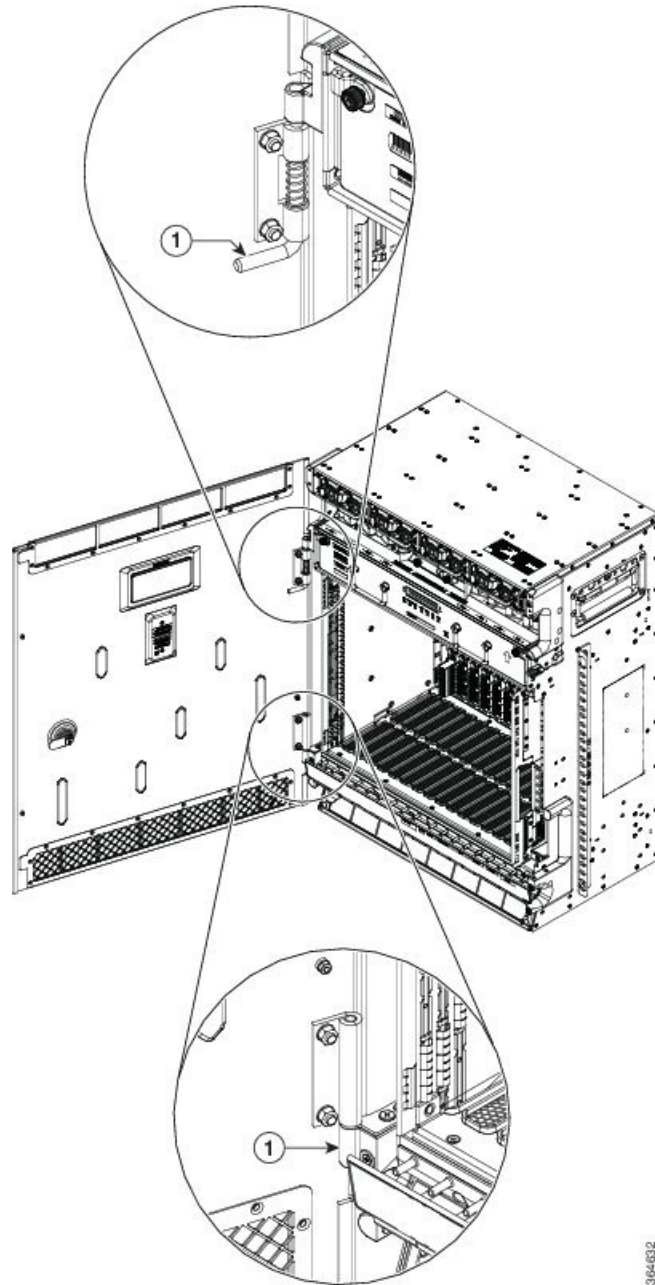
Figure 7: Hinge Pins

1	Hinge pins
---	------------

Note

The ground strap cable is pre-installed on the standard door. See the figure below.

Figure 8: Ground Strap Cable

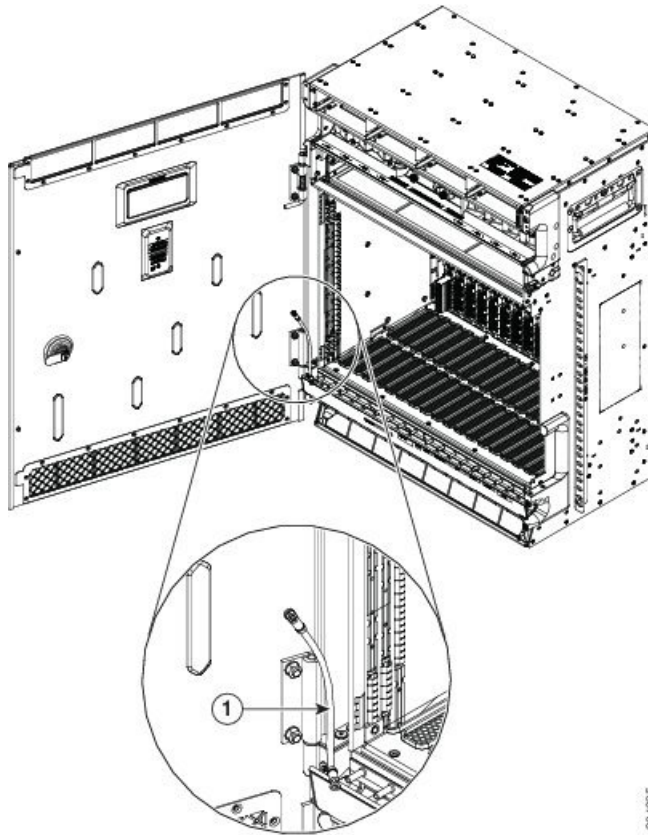

1	Ground strap cable
---	--------------------

Step 4 Swing the door closed and turn the knob to lock.

Note

To lock the door, it is mandatory for the ECU module to be installed and secured with captive screws.

Step 5 Connect the other end of the ground strap cable to a grounding point on the chassis (see the figure below).

Figure 9: Installing the Ground Strap Cable on the NCS 2015 DC Shelf

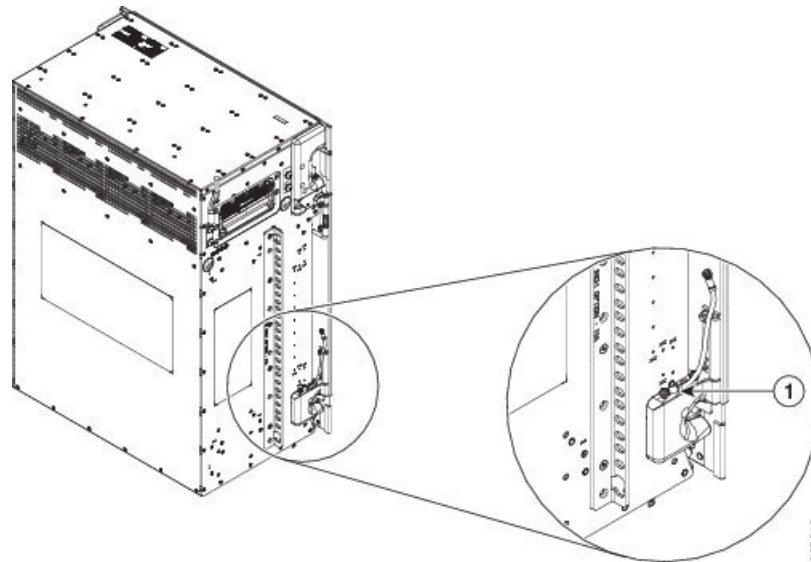

1 Grounding point on the chassis

Stop. You have completed this procedure.

NTP-L61 Installing Deep Door of NCS 2015 Shelf

Purpose	This procedure installs the deep door of the NCS 2015 shelf.
Tools/Equipment	<ul style="list-style-type: none"> • #2 Phillips Dynamometric screwdriver • 10 M3 x 10 mm pan-head screws • One M3 x 8 mm pan-head screw • One M3 x 6 mm pan-head screw
Prerequisite Procedures	<ul style="list-style-type: none"> • NTP-L48 Mounting Brackets on NCS 2015 Shelf for ANSI Rack Configuration • Connect the chassis to the office ground. For detailed instructions on how to ground the chassis, refer to the Electrostatic Discharge and Grounding Guide for Cisco NCS 2000 Series. • NTP-L52 Install NCS 2015 ECU Module, on page 17 • NTP-L57 Installing Power and Ground to the NCS 2015 Shelf • NTP-L54 Installing Fan-Tray Assembly in NCS 2015 Shelf, on page 25 • NTP-L67 Installing Fiber Tray of NCS 2015 Shelf, on page 2
Required/As Needed	As needed
Onsite/Remote	Onsite

Security Level	None
----------------	------

Procedure

- Step 1** Align the left deep door bracket screw holes against the shelf screw holes.
- Step 2** Insert the M3 x 10 mm screws (three screws on the side and two screws on the bottom of the deep door bracket) and tighten them to a torque value of 11.5 in-lb (1.3 N-m). (See the figures below.)
- Step 3** Place a safety washer on the front bottom of the deep door bracket and fasten it with a M3 x 8 mm screw. (See the figures below.)
- Step 4** Repeat steps 1 and 2 for the deep door bracket on the opposite side. (See the figures below.)

Figure 10: Installing the Deep Door Bracket of NCS 2015 DC Shelf

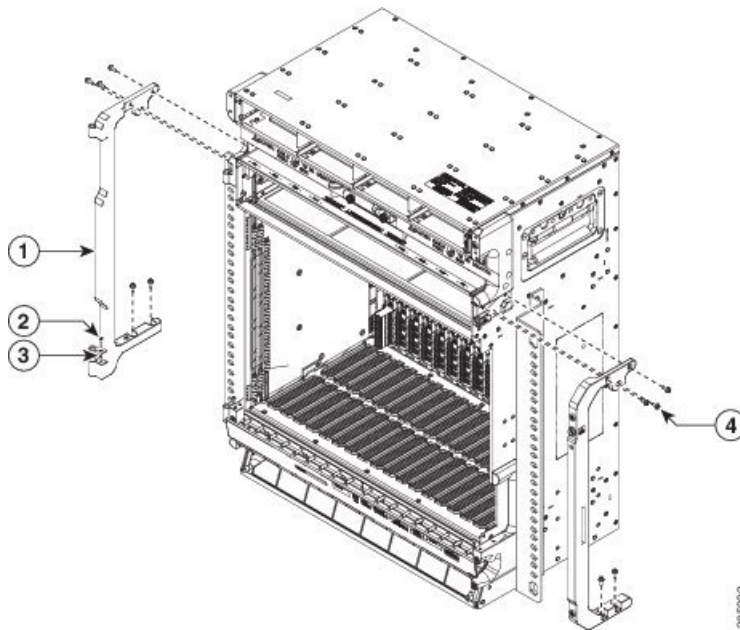

1	Deep door bracket	2	M3 x 8 mm screw
3	Safety washer	4	M3 x 10 mm screw

Figure 11: Installing the Deep Door Bracket of NCS 2015 AC Shelf

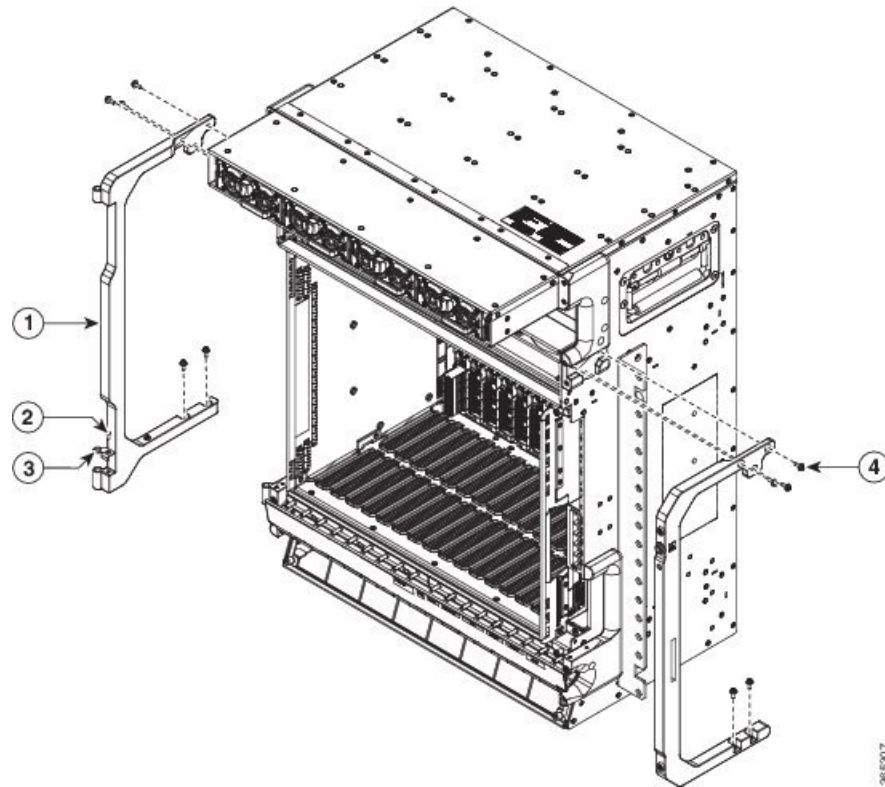

1	Deep door bracket	2	M3 x 8 mm screw
3	Safety washer	4	M3 x 10 mm screw

Step 5 Pull the top hinge pin down on the deep door. (See the figures below.)

Note

The bottom hinge pin is fixed.

Step 6 Align the deep door hinges with the bracket hinges. (See the figures below.)

Step 7 Slide the bottom hinge pin into the bracket hinge and move the top hinge pin in the upward direction.

Note

The ground strap cable is pre-installed on the deep door. (See the figures below.)

Figure 12: Installing the Deep Door and Ground Strap Cable to the NCS 2015 DC Shelf

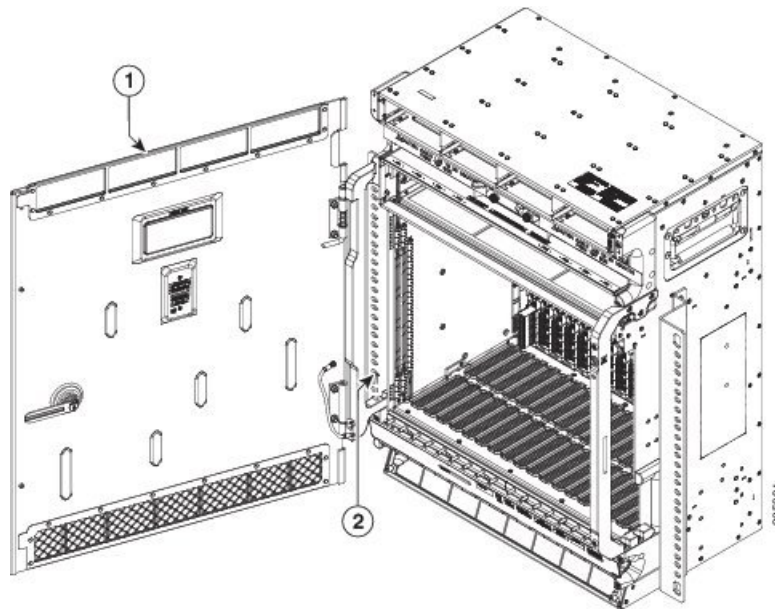

1	Deep door	2	M3 x 6 mm screw
---	-----------	---	-----------------

Figure 13: Installing the Deep Door and Ground Strap Cable to the NCS 2015 AC Shelf

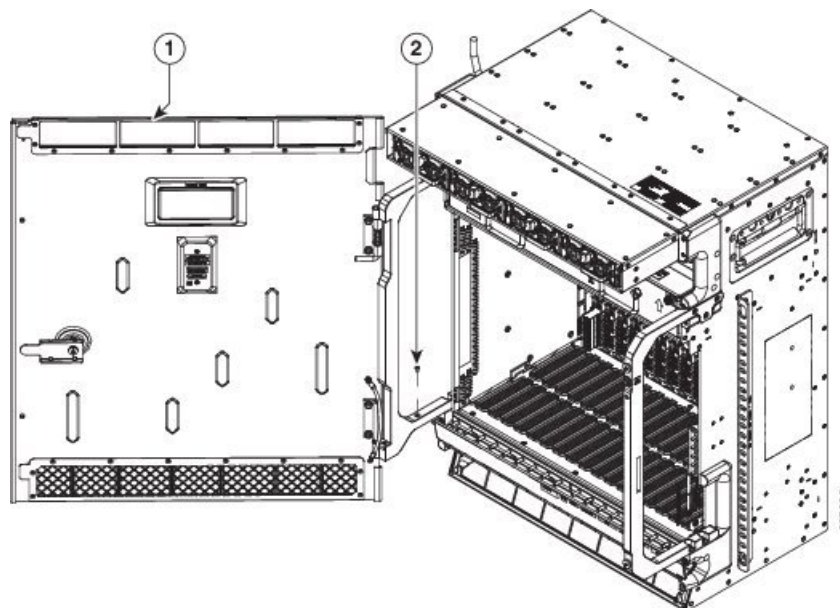

1	Deep door	2	M3 x 6 mm screw
---	-----------	---	-----------------

Step 8 Connect the other end of the ground strap cable to a grounding point on the deep door bracket using a M3 x 6 mm screw. (See the figure below.)

Figure 14: Ground Strap Cable

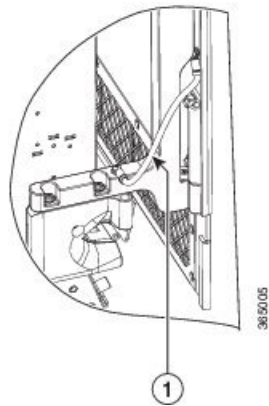

1	Ground strap cable
---	--------------------

Step 9 Swing the door closed and turn the knob to lock. (See the figures below.)

Figure 15: Installed Deep Door in NCS 2015 DC Shelf

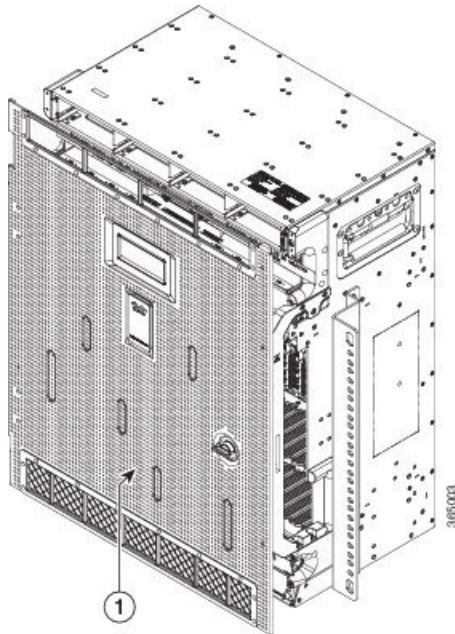

1	Deep door
---	-----------

Figure 16: Installed Deep Door in NCS 2015 AC Shelf

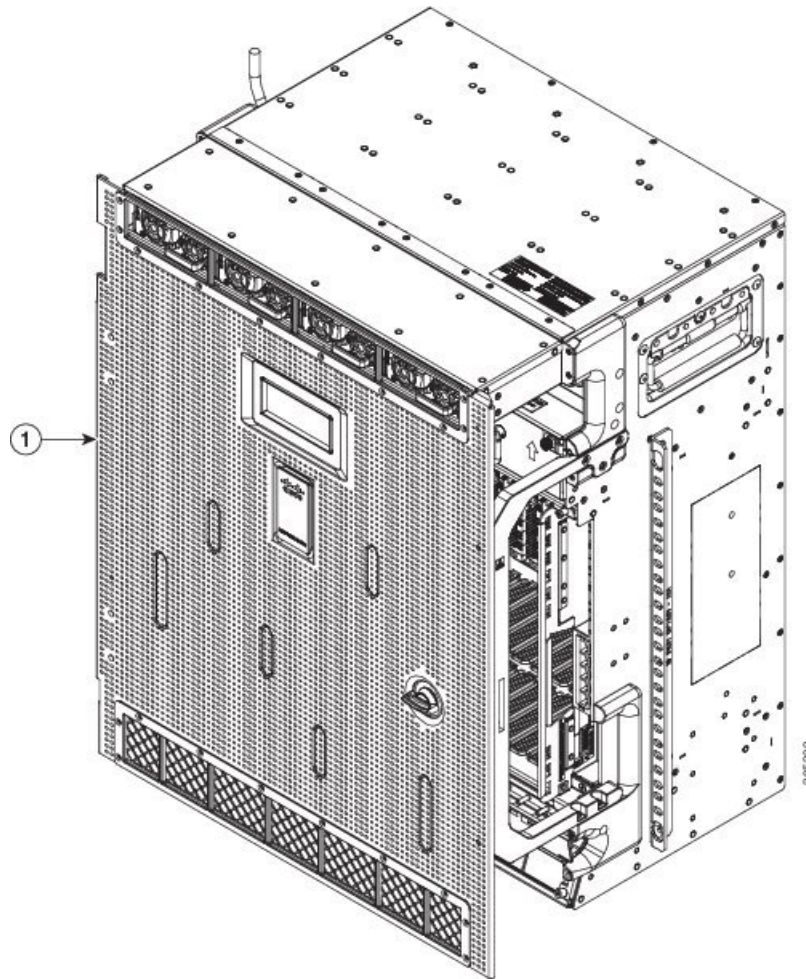

1	Deep door
---	-----------

Stop. You have completed this procedure.

NTP-L51 Opening and Removing the Door of the NCS 2015 Shelf

Purpose	This procedure opens and removes the door of the NCS 2015 shelf.
Tools/Equipment	#2 Phillips Dynamometric screwdriver
Prerequisite Procedures	<ul style="list-style-type: none"> • NTP-L48 Mounting Brackets on NCS 2015 Shelf for ANSI Rack Configuration • Connect the chassis to the office ground. For detailed instructions on how to ground the chassis, see the Electrostatic Discharge and Grounding Guide for Cisco NCS 2000 Series.

Required/As Needed	Required
Onsite/Remote	Onsite
Security Level	None



Note The NCS 2015 shelf has an ESD plug input and is shipped with an ESD wrist strap. The ESD plug input is located on the outside of the shelf on the right side. It is labeled “ESD” on the top and bottom. Always wear an ESD wrist strap and connect the strap to the ESD plug when working on the NCS shelf. For detailed instructions on how to wear the ESD wristband, see the [Electrostatic Discharge and Grounding Guide for Cisco NCS 2000 Series](#).

Procedure

- Step 1** Turn the knob to unlock the door.
- Step 2** Swing the door open.
- Step 3** Remove the ground cable from the shelf by removing the screw.
- Step 4** Pull the top hinge pin holding the door to the chassis, in the downward direction.
- Step 5** Lift the door out of the bottom hinge pin to remove the door from its hinges.

Stop. You have completed this procedure.

External Connection Units

The NCS 2015 external connection unit (ECU) is a replaceable module that provides interfaces for passive device inventory and management, multishelf management, and element management. The ECU module available for the NCS 2015 shelf is NCS2015-ECU and is installed in slot 18 of the NCS 2015 shelf.

The ECU contains RJ-45 and SFP interfaces or multishelf and element management. Fourteen USB ports connect to passive devices, two of which are USB 3.0 ports. A backup flash memory is fitted into the ECU to support the database (DB) and image backup in the operation of the NCS 2015.

The ECU contains two LEDs that indicate the link and activity status of the optical EMS SFP port.

Table 1: ECU LED Status Indicator Lights

LED Name	Color	Description
Link Speed	Green	The LED is on when there is a link connection; otherwise, the LED is off.

LED Name	Color	Description
Activity	Yellow	The LED is flashing when there is activity on the link; otherwise, the LED is off.

The following figure shows the NCS 2015 ECU connectors.

Figure 17: Connectors on the NCS 2015 ECU Faceplate

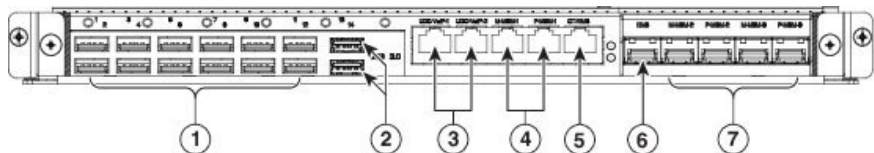

1	USB 2.0 ports (Ports 1 through 12)	2	USB 3.0 ports (Ports 13 and 14)
3	VOIP/UDC ports (RJ-45 port)	4	MSM port (RJ-45 port)
5	EMS port (RJ-45 port)	6	EMS port (SFP port)
7	MSM ports (SFP ports)		

The following table lists the external connections present on the NCS 2015 ECU :

Table 2: NCS 2015 ECU Interfaces

Interface	Connector Type	Quantity
Passive inventory and management	USB 2.0	12
	USB 3.0	2
Multishelf management	RJ-45 (10BASE-T)	2
	SFP (100BASE-FX) ¹	4
Element management system (EMS) or craft terminal	RJ-45 (10BASE-T)	1
	SFP (100BASE-FX)	1
User data channel (UDC)	RJ-45	2

¹ The supported SFP is ONS-S1-100-FX

The ECU cannot be pre-provisioned in CTC. After the ECU is physically plugged into Slot 18 of the NCS 2015 shelf, the unit is detected by CTC and all the entities of the ECU such as the USB ports, RJ-45 ports, and the optical pluggable ports are created in CTC. In the ECU card view in CTC, only the pluggable ports are visible. The ECU card view displays the Alarms, Conditions, History, Provisioning and Maintenance sub-tabs. All the values in these sub-tabs, except for the port name, are display only. Performance monitoring is not supported on the pluggable FE ports of the ECU. The MS-ISC (RJ-45) ports are displayed in the CTC ECU card view > Provisioning > Alarm Profiles > Alarm Behavior tab. The IMPROPRMVL alarm is raised in CTC when the ECU is removed from the NCS 2015 shelf. The ECU entities and the ECU card view in

CTC remain as they are, even though the ECU has been removed from the NCS 2015 shelf. The ECU cannot be deleted in CTC.

The Fiber Shuffle or the CDC fan out unit can be connected to the NCS 2015 ECU using the USB 3.0 port.

Passive Unit Inventory Interfaces

The passive unit inventory interfaces (USB ports) are used to retrieve inventory information from passive devices such as fiber trays, FBG DCU, patch panels, passive multiplexer or demultiplexer, and so on. There are 14 USB (12 USB 2.0 ports and two USB 3.0 ports.) ports on the NCS 2015 ECU. The inventory details are displayed in the Inventory tab in CTC.

MSM

The multishelf management (MSM) port is an RJ-45 or SFP port that is used to connect the NCS 2015 shelf to other NCS 2015 or NCS 2015 shelves that are a part of the multishelf configuration. There are six MSM ports on the NCS 2015 ECU module.

Three MSM ports (one RJ-45 port and two SFP ports) are prefixed with M and correspond to the TNCS card in Slot 1. The other three MSM ports (one RJ-45 port and two SFP ports) are prefixed with P and correspond to the TNCS card in slot 17. The SFP modules must be plugged in for using the optical MSM ports. MSM connections between the NC and SSC can be done using RJ-45 ports, SFP ports, or both. The MSM cable connections can be created between two M-MSM-x ports or two P-MSM-x ports.

VoIP or UDC

VoIP or UDC is an RJ45 port that can be configured to support UDC or VoIP service on an NCS 2015 shelf. There are two VoIP or UDC ports on the NCS 2015 ECU module. The UDC/VoIP-1 port is connected to the TNCS card in Slot 1 and the UDC/VoIP-2 port is connected to the TNCS card in Slot 17. The VoIP or UDC port also supports Power over Ethernet for connecting VoIP equipments.

NTP-L52 Install NCS 2015 ECU Module

Purpose	This procedure installs the external connection unit (ECU) in the NCS 2015 shelf.
Tools/Equipment	Small slot-head screwdriver
Prerequisite Procedures	<ul style="list-style-type: none"> • NTP-L48 Mounting Brackets on NCS 2015 Shelf for ANSI Rack Configuration. • Connect the chassis to the office ground. For detailed instructions on how to ground the chassis, see the Electrostatic Discharge and Grounding Guide for Cisco NCS 2000 Series .
Required/As Needed	Required
Onsite/Remote	Onsite
Security Level	None



Warning The intra-building port(s) of the equipment or subassembly is suitable for connection to intra-building or unexposed wiring or cabling only. The intra-building port(s) of the equipment or subassembly **MUST NOT** metalically connect to interfaces that connect to the OSP or its wiring. These interfaces are designed for use as intra-building interfaces only (Type 2 or Type 4 ports as described in GR-1089-CORE, Issue 5) and require isolation from the exposed OSP cabling. The addition of Primary Protectors is not sufficient protection in order to connect these interfaces metalically to OSP wiring. Statement 7005



Warning To comply with the Telcordia GR-1089 NEBS standard for electromagnetic compatibility and safety, connect the serial high-speed WAN interface ports only to intra-building or unexposed wiring or cable. The intrabuilding cable must be shielded and the shield must be grounded at both ends. The intra-building port(s) of the equipment or subassembly must not be metalically connected to interfaces that connect to the OSP or its wiring. These interfaces are designed for use as intra-building interfaces only (Type 2 or Type 4 ports as described in GR-1089-CORE) and require isolation from the exposed OSP cabling. The addition of Primary Protectors is not sufficient protection in order to connect these interfaces metalically to OSP wiring. Statement 7003



Warning The intra-building port(s) of the equipment or subassembly is suitable for connection to intra-building or unexposed wiring or cabling only. The intra-building port(s) of the equipment or subassembly **MUST NOT** metalically connect to interfaces that connect to the OSP or its wiring. These interfaces are designed for use as intra-building interfaces only (Type 2 or Type 4 ports as described in GR-1089-CORE, Issue 5) and require isolation from the exposed OSP cabling. The addition of Primary Protectors is not sufficient protection in order to connect these interfaces metalically to OSP wiring. Statement 7018



Warning Voltages that present a shock hazard may exist on Power over Ethernet (PoE) circuits if interconnections are made using uninsulated exposed metal contacts, conductors, or terminals. Avoid using such interconnection methods, unless the exposed metal parts are located within a restricted access location and users and service people who are authorized within the restricted access location are made aware of the hazard. A restricted access area can be accessed only through the use of a special tool, lock and key or other means of security. Statement 1072



Caution Always use the ESD wristband when working. See [Electrostatic Discharge and Grounding Guide for Cisco NCS 2000 Series](#).

Procedure

-
- Step 1** Insert the NCS 2015 ECU module in slot 18 of the chassis (see the figure below).
- Step 2** Push the NCS 2015 ECU module such that the backplane connector is completely engaged and the faceplate of the NCS 2015 ECU module aligns with the edge of the chassis side wall.

Step 3 Tighten the captive screw to a torque value of 4 in-lb (0.45 N-m).

Figure 18: Installing the NCS 2015 ECU Module

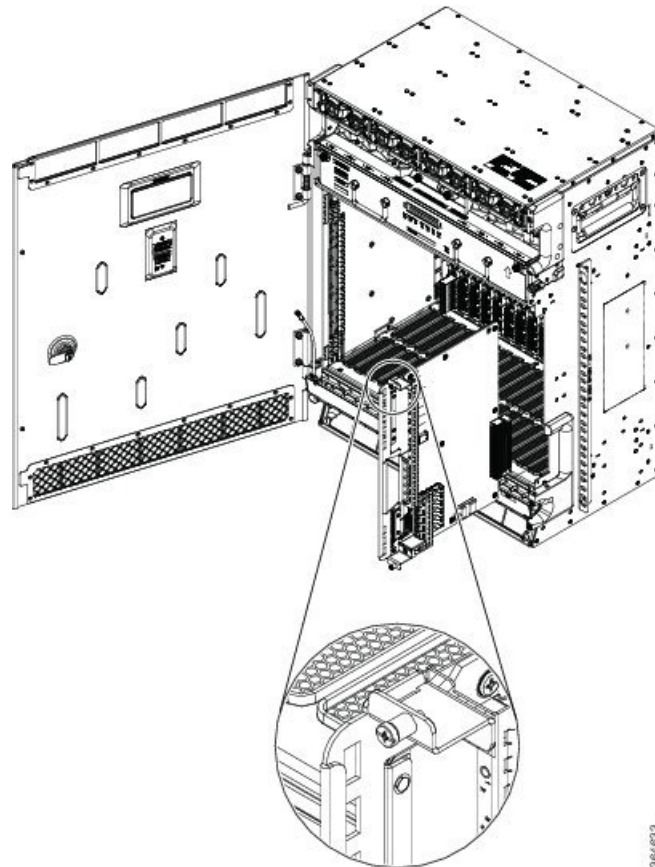

Stop. You have completed this procedure.

Power Modules

The NCS 2015 system contains pluggable and redundant power modules for AC and DC power. The AC and DC power modules cannot be used simultaneously to power the NCS 2015 system. Each power module has three status LEDs located on the front left side of its faceplate.



Note At least one power module must be present in the chassis to boot up the system. The available power module is automatically configured as the Working module. You must configure a Protection module to avoid power shortage in the chassis. Before configuring a Protection module, ensure that the Protection module is available in the chassis.

If the Working module fails, the Protection module takes care of the shelf. If both the Protection and Working modules fail, line cards may shut down due to power shortage and traffic is affected.

Table 3: Power Module LED Status Indicator Lights

LED Name	Color	Description
Input OK	Green	<ul style="list-style-type: none"> • On: The input voltage is present and within regulation range. • Blinking: The input voltage is present but out of regulation range. • Off: The input voltage is not present.
Output OK	Green	<ul style="list-style-type: none"> • On: The output voltage is on. • Blinking: The power module is in a power limit or over current condition. • Off: The output voltage is off.
Fault	Red	<ul style="list-style-type: none"> • On: An internal fault is detected within the power module. • Off: No internal faults detected on the power module.

AC Power Modules

The NCS 2015 system is powered by AC power modules with 1+0, 1+1, 2+0, and 2+2 redundancy. The supported AC power module on the NCS 2015 shelf is NCS4K-AC-PSU. The AC power module converts the AC-input current to DC-output current. Each AC power module has one AC single-phase 3 poles (line L, Neutral N, and Protective Earth PE) input connector.

DC Power Module

The NCS 2015 system is powered by DC power modules with 3+1, 2+2, 2+1, and 1+1 redundancy. The supported DC power module on the NCS 2015 shelf is NCS4K-DC-PSU-V1. The DC power module draws power from the power plant to turn on the NCS 2015 shelf.

The PWR-CON-LMT alarm is raised in the Alarms tab in CTC when the installation or pre-provisioning of a card causes the power consumption to exceed the power limit.

The PWR-CON-LMT alarm is raised on the NCS2015 shelf when the power consumption of the shelf exceeds the maximum power limit. A database backup is performed on the shelf. Additional power modules are installed to increase the power limit. A database restore is then performed on the shelf. The PWR-CON-LMT alarm still persists even though the power consumption is within the power limit.



Note The total power consumption of the shelf is calculated by the controller card and displayed in CTC in the Provisioning > Power Monitor tab.

Power Filler Module

For redundant power supplies, four AC or DC power modules can be installed in the NCS 2015 shelf. However, only one power module can sustain the functioning of the entire NCS 2015 system. You can install power filler modules in the empty slots.

NTP-L53 Installing the Power Modules in NCS 2015 Shelf

Purpose	This procedure installs the power modules in the NCS 2015 system.
Tools/Equipment	#2 Phillips screwdriver
Prerequisite Procedures	<ul style="list-style-type: none"> • NTP-L48 Mounting Brackets on NCS 2015 Shelf for ANSI Rack Configuration or NTP-L49 Mounting Brackets on NCS 2015 Shelf for ETSI Rack Configuration • Connect the chassis to the office ground. For detailed instructions on how to ground the chassis, see the Electrostatic Discharge and Grounding Guide for Cisco NCS 2000 Series .
Required/As Needed	Required
Onsite/Remote	Onsite
Security Level	None



Warning The plug-socket combination must be accessible at all times because it serves as the main disconnecting device. Statement 1019

Procedure

- Step 1** Complete [DLP-L82 Installing AC Power Module in NCS 2015 Shelf](#), on page 21
- Step 2** Complete [DLP-L75 Installing DC Power Module in NCS 2015 Shelf](#), on page 22
- Step 3** Complete the [NTP-L57 Installing Power and Ground to the NCS 2015 Shelf](#).

Stop. You have completed this procedure.

DLP-L82 Installing AC Power Module in NCS 2015 Shelf

Purpose	This procedure installs the NCS4K-AC-PSU power module in the NCS 2015 shelf.
Tools/Equipment	#2 Phillips Dynamometric screwdriver

Prerequisite Procedures	none
Required/As Needed	Required
Onsite/Remote	Onsite
Security Level	None

Procedure

Step 1 Remove the filler caps from the slots where you want to install the power modules.

Figure 19: Installing the AC power module

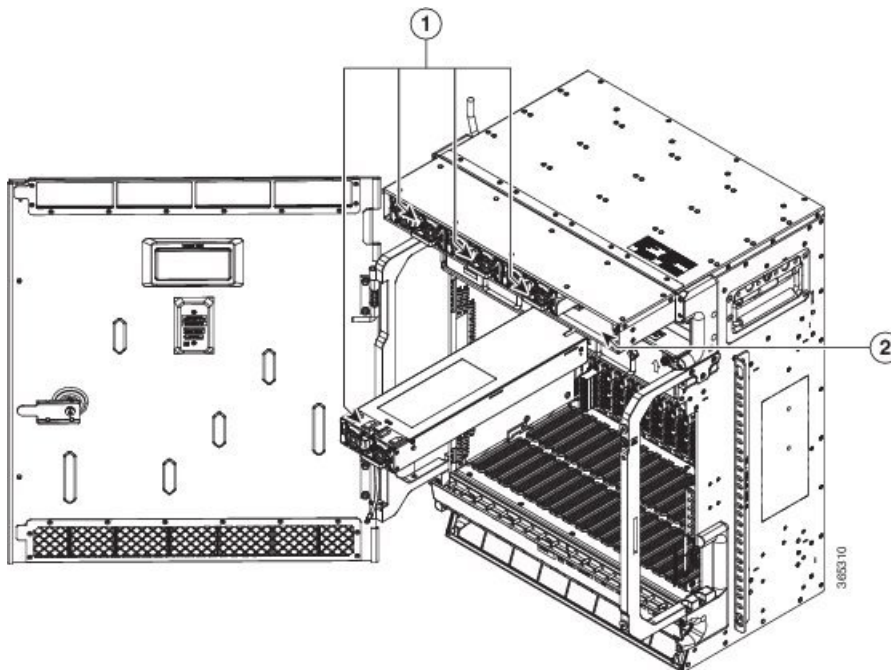

1	AC power module	2	Power tray
---	-----------------	---	------------

Step 2 Using both hands to support the power module, slide it into the power slot (See figure above).

Step 3 Secure the power module into the power tray using the snap hook.

Step 4 Repeat Steps 1 through 3 for the other AC power modules.

Step 5 Return to your originating procedure (NTP).

DLP-L75 Installing DC Power Module in NCS 2015 Shelf

Purpose	This procedure installs the NCS4K-DC-PSU-V1 power module in the NCS 2015 shelf.
----------------	---

Tools/Equipment	#2 Phillips Dynamometric screwdriver
Prerequisite Procedures	none
Required/As Needed	Required
Onsite/Remote	Onsite
Security Level	None

Procedure

Step 1 Remove the filler caps from the slots where you want to install the power modules.

Figure 20: Installing the DC power module

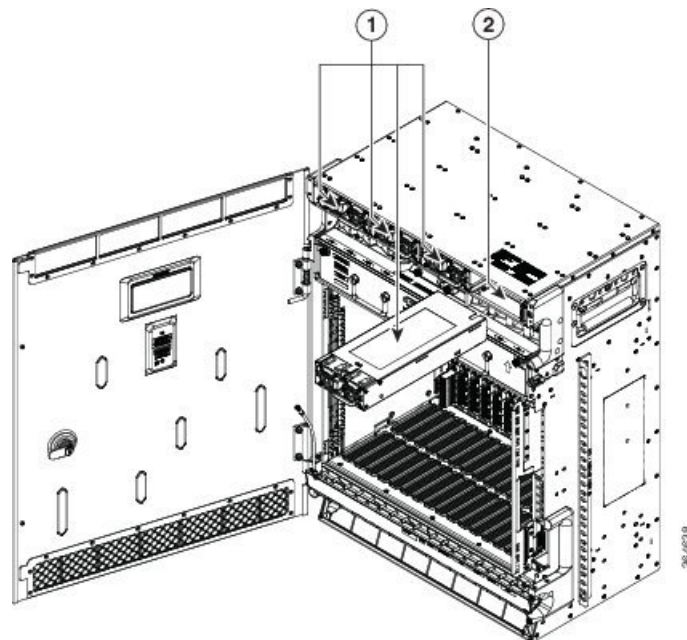

1	DC power module	2	Power tray
---	-----------------	---	------------

Step 2 Using two hands to support the power module, slide it into the power slot (see the figure above).

Step 3 Secure the power module into the power tray using the snap hook.

Step 4 Repeat the above steps for the other DC power modules.

Step 5 Return to your originating procedure (NTP).

LCD Unit

The LCD unit is integrated with the fan tray assembly and consists of an LCD display panel, push button, and shelf-level LED indicators on the NCS 2015 system.

The shelf controller card (TNCS) powers the 16 x 2 character LCD screen. The LCD screen displays the shelf name, shelf IP address, and software version currently used. The LCD screen also provides slot-level and port-level information of all card slots, including the number of critical, major, and minor alarms. The display contrast is automatically adjusted for a clearer view. The three accessible push buttons (SLOT, STATUS, and PORT) on the LCD unit are used to set parameters at the slot-level and port-level. There are three alarm LEDs (CRIT, MAJ, and MIN) on the LCD unit that indicate whether a critical, major, or minor alarm is present anywhere on the NCS 2015 shelf. There is also a Fan Fail LED. When the fan-tray assembly is not functioning or when the power line is not connected, the LED is OFF. When the power line is connected and if there is no TNCS card installed in the NCS2015 shelf, then the LED is OFF. A red LED indicates an alarm in the fan-tray assembly. A green LED indicates that the fan-tray assembly is functioning, the power line is connected, and the power module is functioning properly. The shelf controller card controls the conditions that result in triggering the LEDs. The LEDs can be overwritten by the shelf controller card (TNCS) in all the three states (OFF/red/green). The LCD unit supports the lamp test procedure and the LEDs changes its color or state.

Fan-Tray Assembly

The fan-tray supported on the NCS 2015 shelf is NCS2015-FTA.

The fan-tray assembly is located on the front side of the NCS 2015 shelf. The fan-tray is removable and holds the fan-control circuitry and the fans for the NCS 2015 shelf. The fan tray has 9 x 92mm x 48mm fans that are capable of pulling enough air to cool up to 300 W per LC with optimum placement and components at both 27C NEBS acoustic level and 55C NEBS extended temperature range. The fan tray also accommodates LCD panel and its circuitry. The fan-tray assembly supports the lamp test procedure. After you install the fan tray, you should only access it when a fan failure occurs.

Fan Speed

The fan speed is controlled by the TNCS card temperature sensors. The sensors measure the input air temperature at the fan-tray assembly. If the TNCS card fails, the fans automatically shift to high speed. The temperature that the TNCS sensors measure appears on the LCD screen.

Fan Failure

If one or more fans fail on the fan-tray assembly, replace the entire assembly. You cannot replace individual fans. The FAN-DEGRADE alarm is raised when one fan fails and the Fan Fail LED in the LCD unit glows with amber color. The FAN-FAIL alarm is raised when two or more fans fail and the Fan Fail LED glows with red color. The Fan Fail LED clears after you install a working fan-tray.

NTP-L54 Installing Fan-Tray Assembly in NCS 2015 Shelf

Purpose	This procedure installs the NCS2015-FTA fan-tray assembly in the NCS 2015 system.
Tools/Equipment	Small slot-head screwdriver
Prerequisite Procedures	<ul style="list-style-type: none"> • NTP-L48 Mounting Brackets on NCS 2015 Shelf for ANSI Rack Configuration. • Connect the chassis to the office ground. For detailed instructions on how to ground the chassis, refer to the Electrostatic Discharge and Grounding Guide for Cisco NCS 2000 Series .
Required/As Needed	Required
Onsite/Remote	Onsite
Security Level	None



Caution Do not operate an NCS 2015 chassis without the fan tray for more than two minutes.



Warning Do not reach into a vacant slot when installing or removing the fan tray. Exposed circuitry is an energy hazard. Statement 206



Caution When the fan tray is removed, shock hazard is possible. Do not introduce any object into the fan tray slot nor touch the empty slot. Install the fan tray immediately.



Caution Do not force a fan-tray assembly into place. Doing so can damage either the connectors on the fan tray or the connectors on the back panel of the shelf, or both.



Note Error messages appear on the TNCS/TNCS-O card, the fan-tray LED, and in the Cisco Transport Controller (CTC) when the fan-tray assembly is removed from the shelf or when a fan is not working.



Note To install the fan-tray assembly, it is not necessary to move any of the fiber-routing facilities.

Figure 21: Shock Hazard Label - NCS 2015 AC Shelf

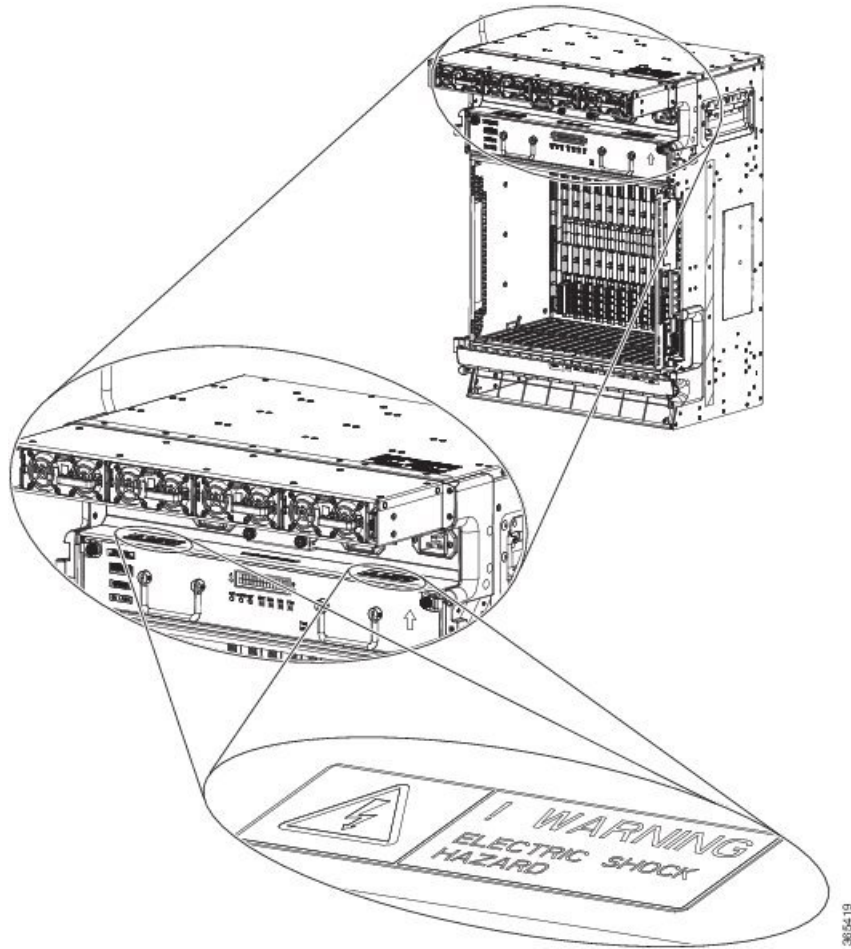

Procedure

-
- Step 1** Orient the fan tray as specified on front label.
 - Step 2** Move the ejectors down into the stop or block position.
 - Step 3** Slide the fan tray into the chassis slot. (see the figure below).

Figure 22: Installing the Fan-Tray Assembly in NCS 2015 DC Shelf

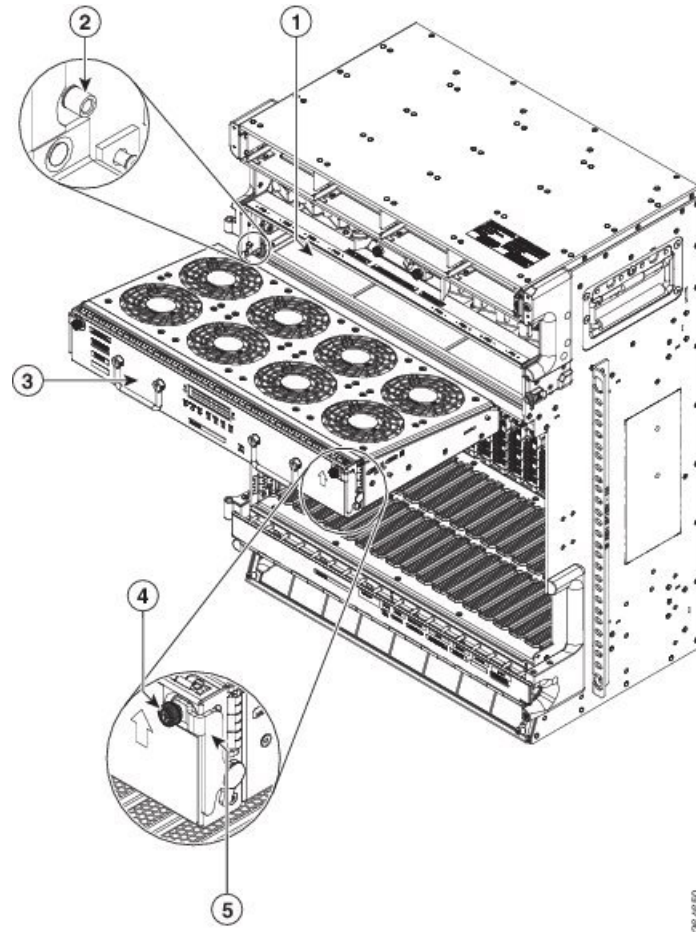

1	Fan tray slot	2	Fan tray guide and lock pin
3	Fan tray	4	Screw
5	Fan tray guide and lock plate		

Step 4 Push the fan-tray assembly such that the backplane connector is engaged completely.

Step 5 Tighten the captive screws to a torque value of 4 in-lb (0.45 N-m) to lock the fan-tray assembly into the chassis (see the figure below).

Figure 23: Fan Tray Assembly Installed in NCS 2015 DC Shelf

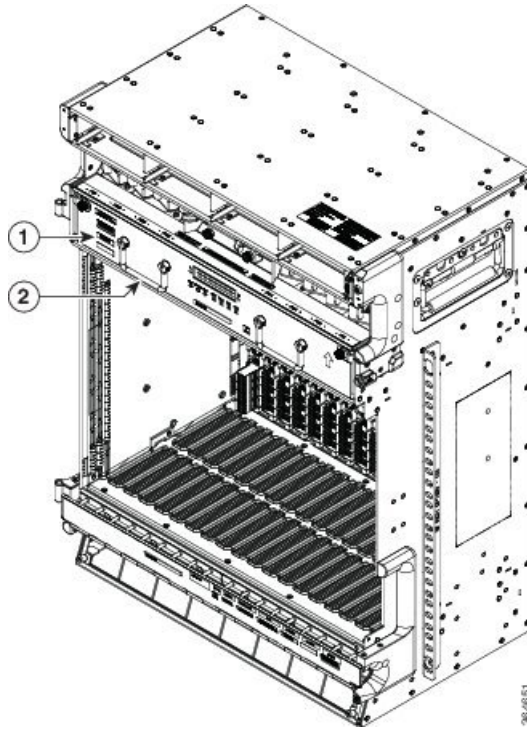

1	Fan tray	2	Fan tray handle
---	----------	---	-----------------

Step 6

To verify that the tray has plugged into the assembly, check the fan tray and listen to determine if the fans are running. When the power line is connected, a green LED indicates that the fan-tray assembly is functioning. If power has not yet been turned on, verify that the fan tray is seated and secured with the captive screws.

Stop. You have completed this procedure.

Air Filter

The NCS 2015 contains a preinstalled disposable air filter (NCS2015-FTF) on the bottom side of the shelf.

The disposable filter is made up of a gray, open-cell, polyurethane foam that is specially coated to provide fire and fungi resistance. Spare filters should be kept in stock. Inspection of the air filter must be performed as specified in your local site practices.

First inspection of the air filter should be performed six months after the system installation. Air filters must be inspected every quarter after the initial six month inspection. If they are dirty or clogged with dust, they must be replaced with a new air filter.



Caution Do not operate an NCS 2015 without the mandatory air filter.