



Installing the Cisco NCS 2006 Door and Other Modules

This chapter explains how to install the NCS 2006 door and other modules.

The sections are:

- [Front Door, on page 1](#)
- [NTP-L4 Installing the Standard Door of the NCS 2006 Shelf , on page 3](#)
- [NTP-L5 Opening and Removing the Standard Door of the NCS 2006 Shelf , on page 7](#)
- [NTP-L39 Install the Deep-Front Panel of the NCS 2006 , on page 11](#)
- [NTP-L40 Remove the Deep-Front Panel of the NCS 2006 Shelf , on page 17](#)
- [External Connection Units, on page 20](#)
- [NTP-L8 Install the NCS 2006 ECU and ECU-S Modules, on page 25](#)
- [NTP-L66 Upgrading to NCS 2006 ECU60-S Module, on page 28](#)
- [Power Modules, on page 29](#)
- [NTP-L9 Installing the Power Modules in the NCS 2006 Shelf , on page 30](#)
- [LCD Unit, on page 38](#)
- [NTP-L10 Installing the LCD Module in the NCS 2006 Shelf, on page 39](#)
- [Fan-Tray Assembly , on page 41](#)
- [NTP-L11 Installing the Fan-Tray Assembly in the NCS 2006 Shelf, on page 41](#)
- [Air Filter , on page 43](#)

Front Door

The front door of NCS 2006 provides access to the shelf, fiber-routing tray, fan-tray assembly, and LCD screen.

There are two types of front doors that act as protective panels—standard door and deep door. The deep door provides additional space in front of the shelf to accommodate cables that do not fit inside the standard door. The deep door does not have a hinge and cannot be rotated like the standard door.

If a standard front door was ordered, the NCS 2006 is shipped with a preinstalled standard door. If a deep door was ordered, a temporary front door is preinstalled on the shelf and the deep door is present in a separate package. If no door was ordered, a temporary front door is preinstalled on the shelf.



Note The temporary door is used only for shipping purpose and must not be used in the chassis. The temporary door can be opened by removing the tape that is present on top of the door.

You must remove the door before proceeding with the shelf installation.

The NCS 2006 door can be opened by loosening the front screws and pushing the latch in the opposite direction. You can remove the front door to provide unrestricted access to the front of the shelf.

The laser warning label is placed on top of the chassis.

The figure below shows the NCS 2006 laser warning.

Figure 1: Laser Warning on the NCS 2006

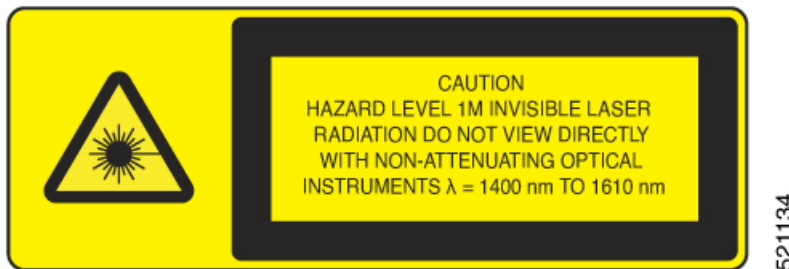

The figure below shows the label that is placed on top of NCS 2006:

Figure 2: NCS 2006 Label



Figure 3: NCS 2006 Front Door Label

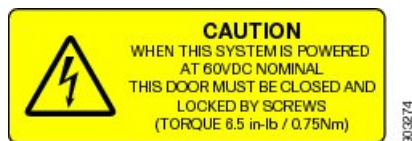

NTP-L4 Installing the Standard Door of the NCS 2006 Shelf

Purpose	This procedure installs the standard door of the NCS 2006 shelf.
Tools/Equipment	#2 Phillips Dynamometric screwdriver
Prerequisite Procedures	<ul style="list-style-type: none"> • NTP-L5 Opening and Removing the Standard Door of the NCS 2006 Shelf , on page 7 • NTP-L2 Mounting the Brackets in ANSI Configuration • Connect the chassis to the office ground. For detailed instructions on how to ground the chassis, see the Electrostatic Discharge and Grounding Guide for Cisco NCS 2000 Series . • NTP-L8 Install the NCS 2006 ECU and ECU-S Modules, on page 25 • NTP-L9 Installing the Power Modules in the NCS 2006 Shelf , on page 30 • NTP-L10 Installing the LCD Module in the NCS 2006 Shelf, on page 39 • NTP-L12 Installing Power and Ground to the NCS 2006 Shelf • NTP-L11 Installing the Fan-Tray Assembly in the NCS 2006 Shelf, on page 41 • NTP-L13 Installing the Cable and Fiber Modules • NTP-L14 Attaching Wires to Alarm, Timing, LAN, and Craft Pin Connections
Required/As Needed	As needed
Onsite/Remote	Onsite
Security Level	None

Procedure

-
- Step 1** Pull the hinge pins on the standard door in the opposite directions (see the figure below).

Figure 4: Installing the Standard Door

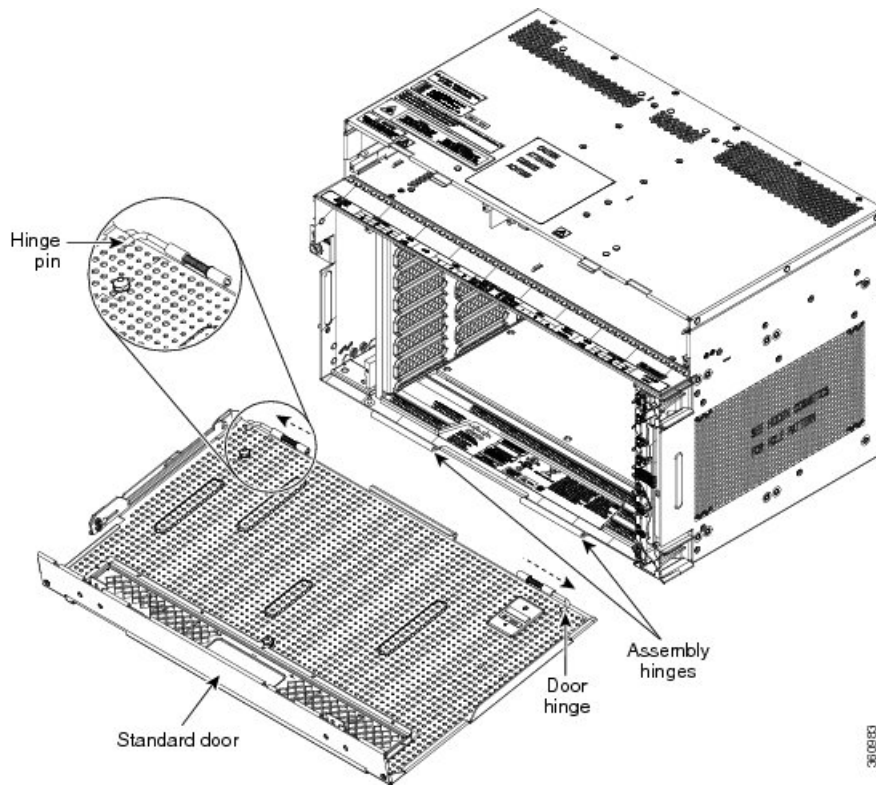

- Step 2** Align the standard door hinges with the chassis hinges.
- Step 3** Release the hinge pins.
- Step 4** Pull the retention feature from the door (see the figure below).
- Step 5** Loosen the screws and place the mechanical stop on the retention feature. (See Diagram 1 of the figure below.)
- Step 6** Place the retention feature on the pin present on the chassis. (See Diagram 2 of the figure below.)
- Step 7** Raise the door to slide the pin. (See Diagram 3 of the figure below.)
- Step 8** Slide the mechanical stop to lock the door position and tighten the screws. (See Diagram 4 of the figure below.)

Note

Reinstall the door after installing all the other modules.

Figure 5: Mounting the Mechanical Stop

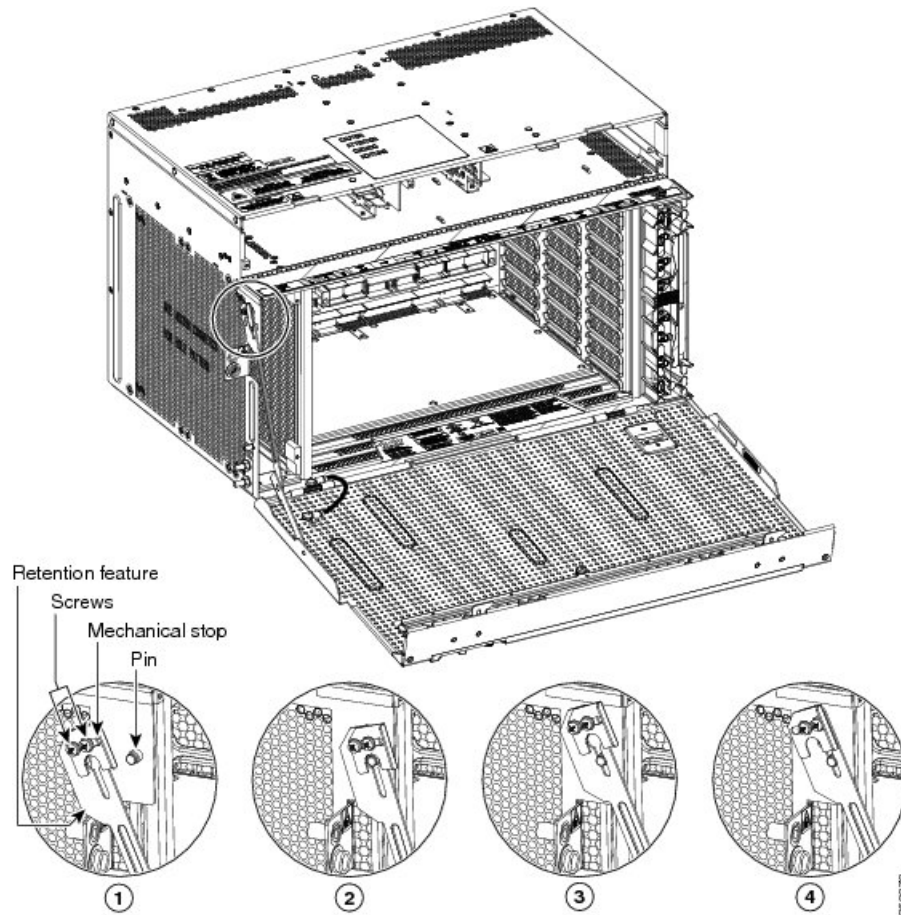

Step 9

Place the ground strap cable (see the figure below) on the door and the chassis and tighten the nuts to a torque value of 11.5 in-lb (1.3 N-m) to lock the cable.

Figure 6: Retention Feature and Ground Strap Cable—Standard Door

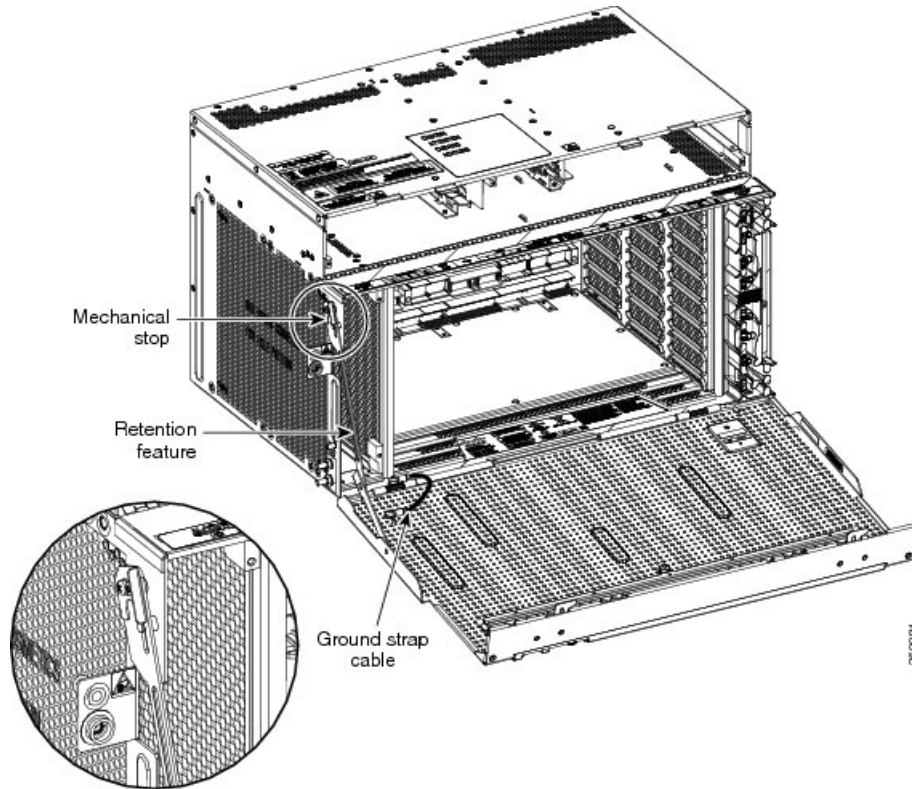

Step 10

Tighten the door screws to a torque value of 6.5 in-lb (0.75 N-m) to close the standard door as shown in the figure below.

Figure 7: Closing the Standard Door of the NS 2006 Shelf

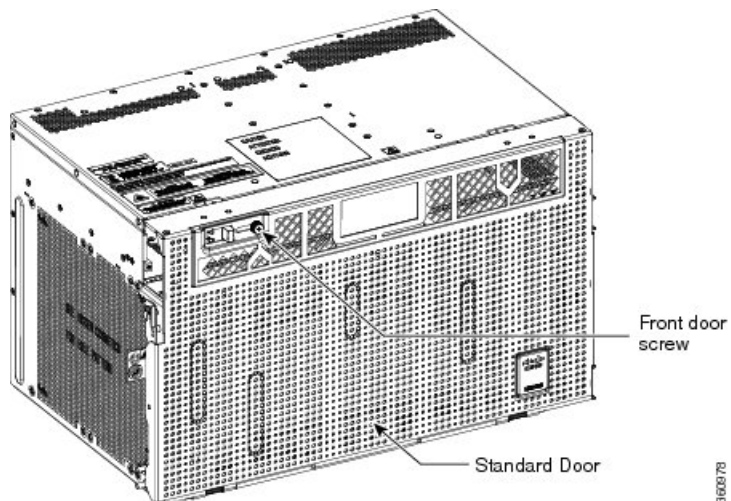

Stop. You have completed this procedure.

NTP-L5 Opening and Removing the Standard Door of the NCS 2006 Shelf

Purpose	This procedure opens and removes the standard door of the NCS 2006 shelf.
Tools/Equipment	#2 Phillips Dynamometric screwdriver
Prerequisite Procedures	<ul style="list-style-type: none"> • NTP-L2 Mounting the Brackets in ANSI Configuration • Connect the chassis to the office ground. For detailed instructions on how to ground the chassis, see the Electrostatic Discharge and Grounding Guide for Cisco NCS 2000 Series .
Required/As Needed	Required
Onsite/Remote	Onsite
Security Level	None

Procedure

-
- Step 1** Complete [DLP-L12 Opening the Standard Door of the NCS 2006 Shelf](#) , on page 7.
- Step 2** Complete the [DLP-L13 Removing the Standard Door of the NCS 2006 Shelf](#) , on page 9.
- Stop. You have completed this procedure.**
-

DLP-L12 Opening the Standard Door of the NCS 2006 Shelf

Purpose	This task opens the standard door of the NCS 2006 shelf.
Tools/Equipment	#2 Phillips Dynamometric screwdriver
Prerequisite Procedures	<ul style="list-style-type: none"> • NTP-L2 Mounting the Brackets in ANSI Configuration • Connect the chassis to the office ground. For detailed instructions on how to ground the chassis, see the Electrostatic Discharge and Grounding Guide for Cisco NCS 2000 Series .
Required/As Needed	Required
Onsite/Remote	Onsite
Security Level	None



Note The NCS 2006 shelf has an ESD plug input and is shipped with an ESD wrist strap. The ESD plug input is located on the outside of the shelf on the left side. It is labeled “ESD” on the top and bottom. Always wear an ESD wrist strap and connect the strap to the ESD plug when working on the NCS. For detailed instructions on how to wear the ESD wristband, see the [Electrostatic Discharge and Grounding Guide for Cisco NCS 2000 Series](#).

Procedure

Step 1 Loosen the standard door screws to a torque value of 6.5 in-lb (0.75 N-m).

Step 2 Push the latches in the opposite direction.

Figure 8: Opening the Standard Door

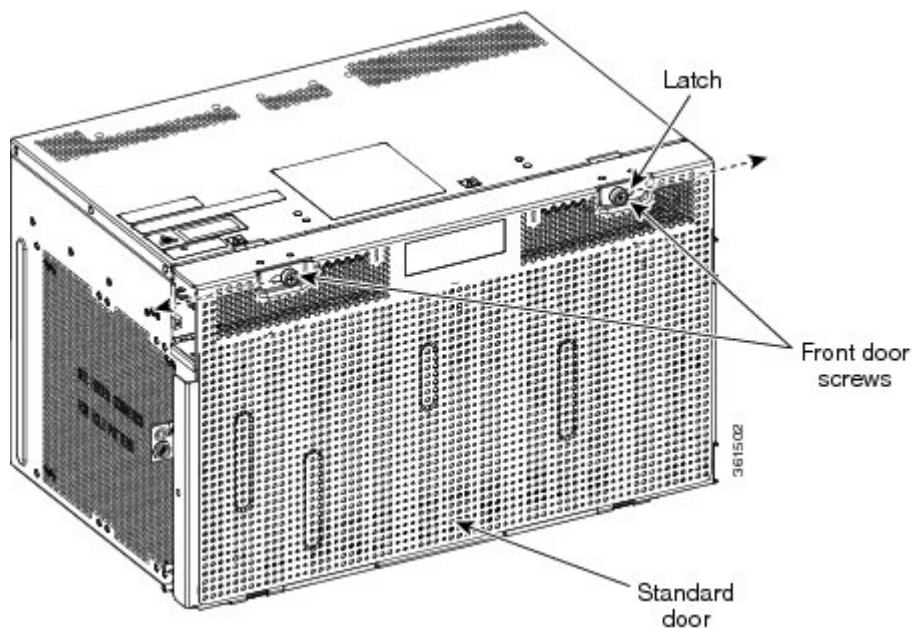

Step 3 Swing the door open. The retention feature maintains the door in the horizontal position for line card insertion (see the figure below).

Figure 9: Cisco NCS 2006 Standard Door—Opened

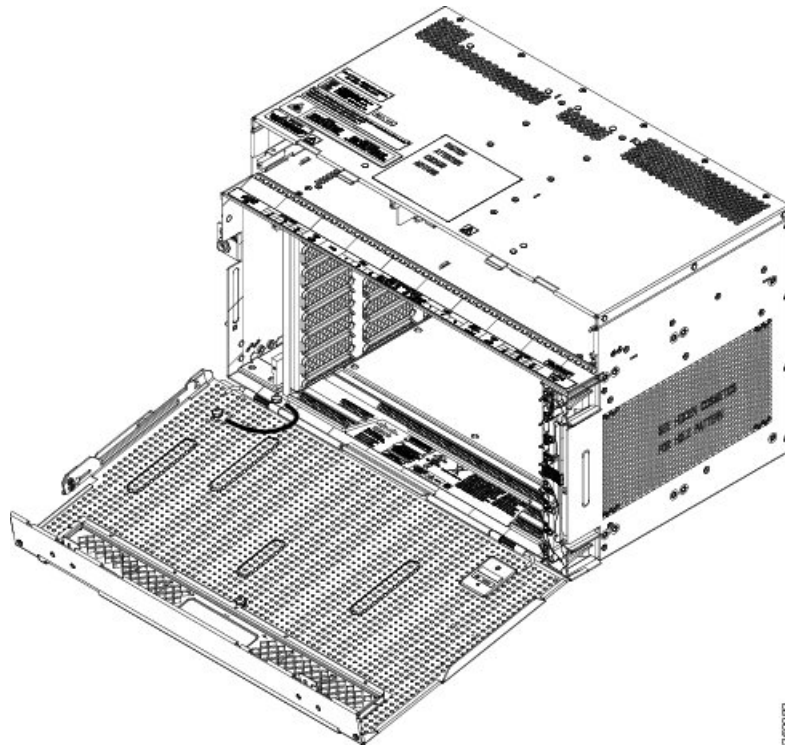

Step 4 Return to your originating procedure (NTP).

DLP-L13 Removing the Standard Door of the NCS 2006 Shelf

Purpose	This task removes the standard door of the NCS 2006 shelf.
Tools/Equipment	None
Prerequisite Procedures	DLP-L12 Opening the Standard Door of the NCS 2006 Shelf , on page 7
Required/As Needed	As needed
Onsite/Remote	Onsite
Security Level	None

Procedure

- Step 1** Unscrew the nut holding the ground cable to the shelf. Remove the nut.
- Step 2** Remove the ground cable from the shelf (see the figure below).

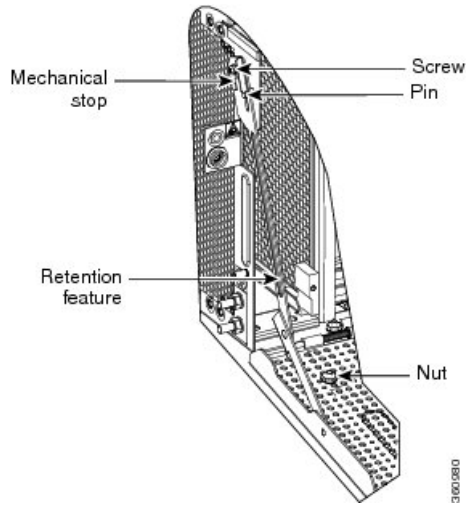
Figure 10: Removing the NCS 2006 Standard Door

- Step 3** Loosen the screws and slide the mechanical stop to unlock the door.
- Step 4** Lower the door to slide the pin.
- Step 5** Remove the retention feature from the pin present on the chassis.
- Step 6** Pull the hinge pins holding the door to the chassis, in the opposite direction (see the figure below).
- Step 7** Remove the door from its hinges (see the figure below).

Figure 11: Removing the NCS 2006 Standard Door

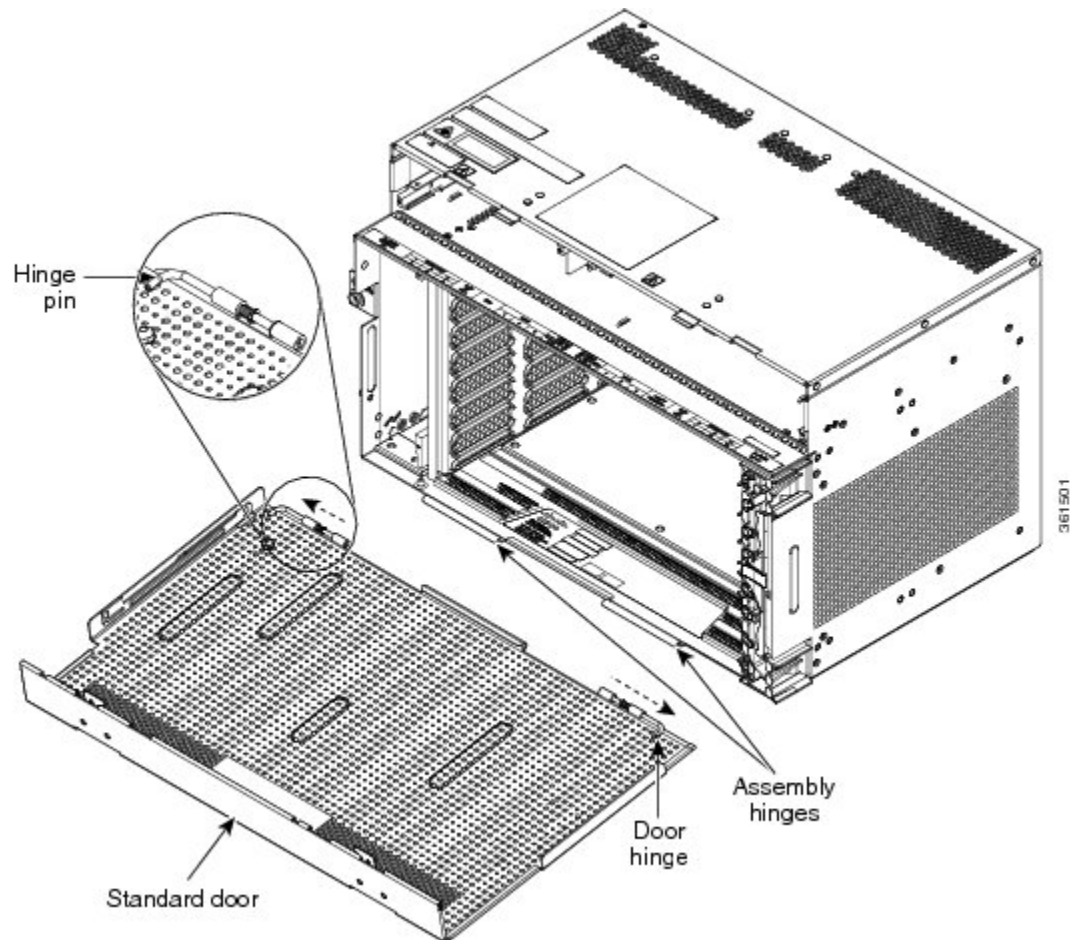

Step 8 Return to your originating procedure (NTP).

NTP-L39 Install the Deep-Front Panel of the NCS 2006

Purpose	This procedure installs the deep-front panel of the NCS.
Tools/Equipment	#2 Phillips Dynamometric screwdriver

Prerequisite Procedures	<ul style="list-style-type: none"> • Remove the temporary door by removing the tape that is present on top of the door. • NTP-L3 Mounting the NCS 2006 Shelf. • Connect the chassis to the office ground. For detailed instructions on how to ground the chassis, see the Electrostatic Discharge and Grounding Guide for Cisco NCS 2000 Series. • NTP-L8 Install the NCS 2006 ECU and ECU-S Modules, on page 25 • NTP-L9 Installing the Power Modules in the NCS 2006 Shelf, on page 30 • NTP-L10 Installing the LCD Module in the NCS 2006 Shelf, on page 39 • NTP-L12 Installing Power and Ground to the NCS 2006 Shelf • NTP-L11 Installing the Fan-Tray Assembly in the NCS 2006 Shelf, on page 41 • NTP-L13 Installing the Cable and Fiber Modules • NTP-L14 Attaching Wires to Alarm, Timing, LAN, and Craft Pin Connections
Required/As Needed	As needed
Onsite/Remote	Onsite
Security Level	None



Note Use the deep-front panel when ONS-SC+-10G-C pluggables are installed on a NCS2006 shelf.



Note When the deep front-panel is installed, the total chassis depth is 12.9 inches. The deep front-panel extends from the rack by 1.8 inches.

Procedure

Step 1

Connect the ground strap cable to the shelf:

- a) Loosen and remove the ground nut from the shelf. See the figure below.
- b) Insert the lug of the ground strap cable and tighten the nut on the shelf to a torque value of 11.5 in-lb (1.3 N-m).
- c) Route the other end of the ground strap cable outside the shelf at an angle of 180 degrees towards the left direction.

Figure 12: Inserting the Lug to the Shelf

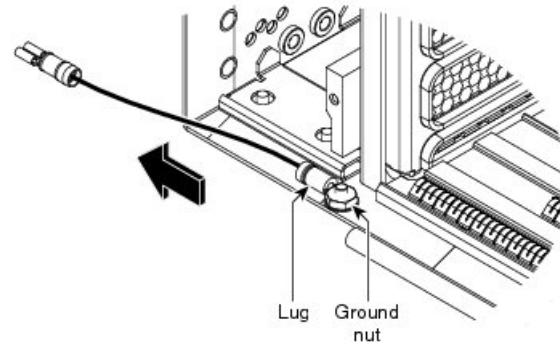

Step 2 Loosen the deep-front panel screws and slide them outwards using the plastic tabs (see the figure below).

Figure 13: Loosening the deep-front panel screws

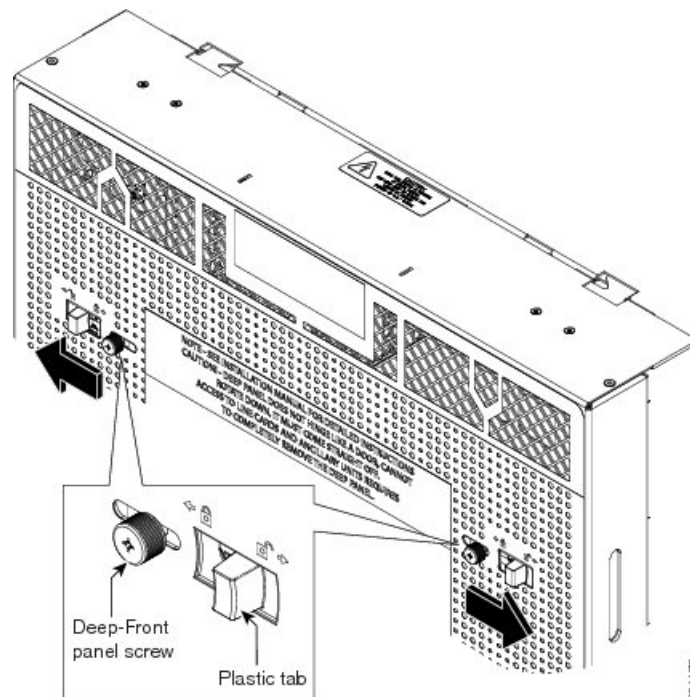

Step 3 Place the deep-front panel close to the shelf so that the shelf notches and the deep-front panel retention features are in line, as shown in the figure below.

Figure 14: Placing Deep-Front Panel and Shelf in line

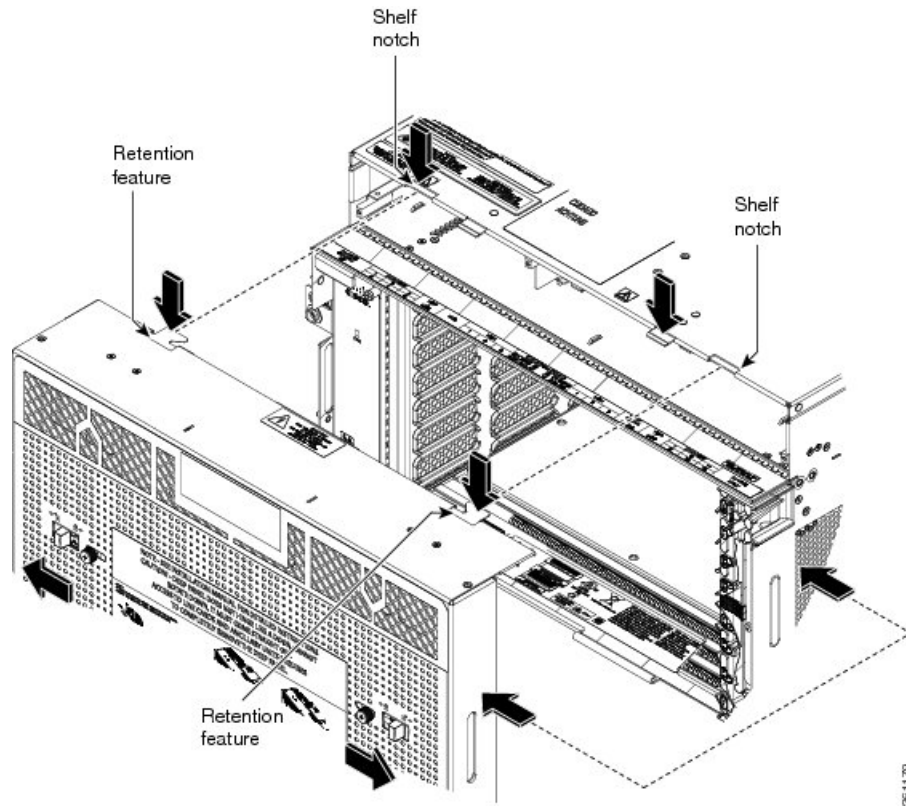

- Step 4** Align the deep-front panel with the shelf by performing the following sub-steps at the same time.
- Align the right and left retention features of the deep-front panel with the right and left notches present on the top of the shelf. See the above figure.
 - Align the deep-front panel pins present at the bottom of the panel with the shelf hinges. See the figure below.

Figure 15: Align the Deep-Front Panel Pins and Shelf Hinges

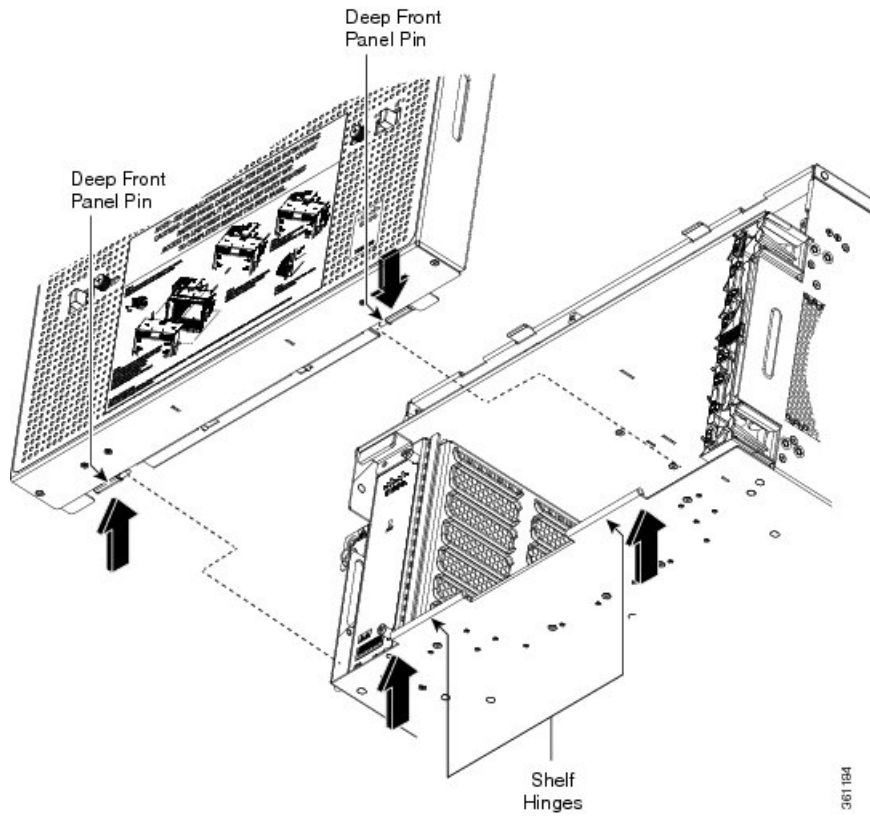

The following figure shows the deep-front panel aligned with the shelf.

Figure 16: Align the Deep-Front Panel and Shelf

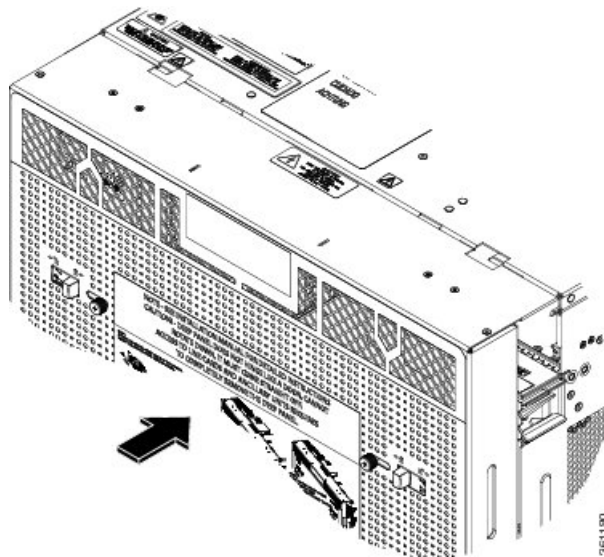

- Step 5** Slide the deep-front panel screws inwards using the plastic tabs to engage the retention features and the pins with the shelf notches and hinges. See the figure below. Verify the engagement by gently applying the pressure to the panel outwards.

Figure 17: Engage the Deep-Front Panel and Shelf

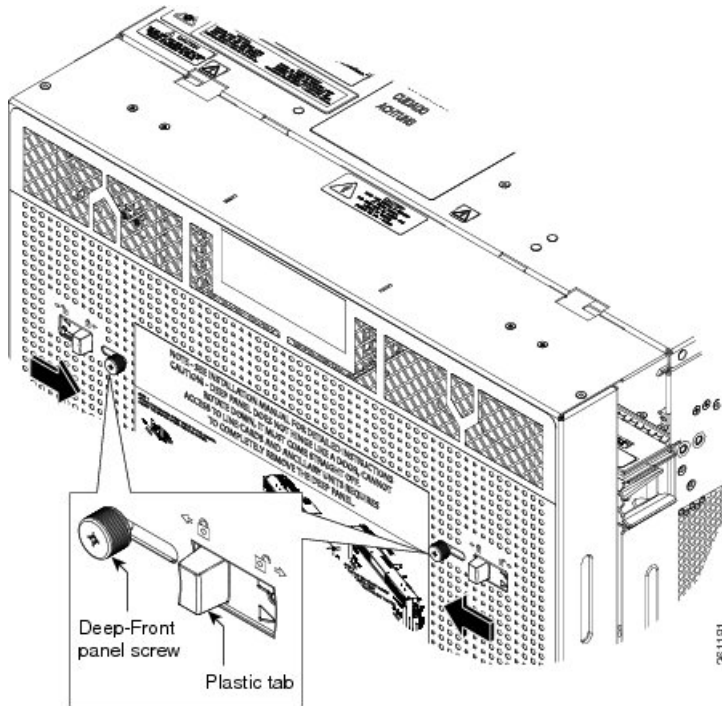

- Step 6** Lock the deep-front panel by tightening the screws to a torque value of 6.5 in-lb (0.75 N-m).
- Step 7** Connect the other end of the ground strap cable to the ground point present on the deep-front panel exterior.

Figure 18: Connect ground strap cable to the ground point

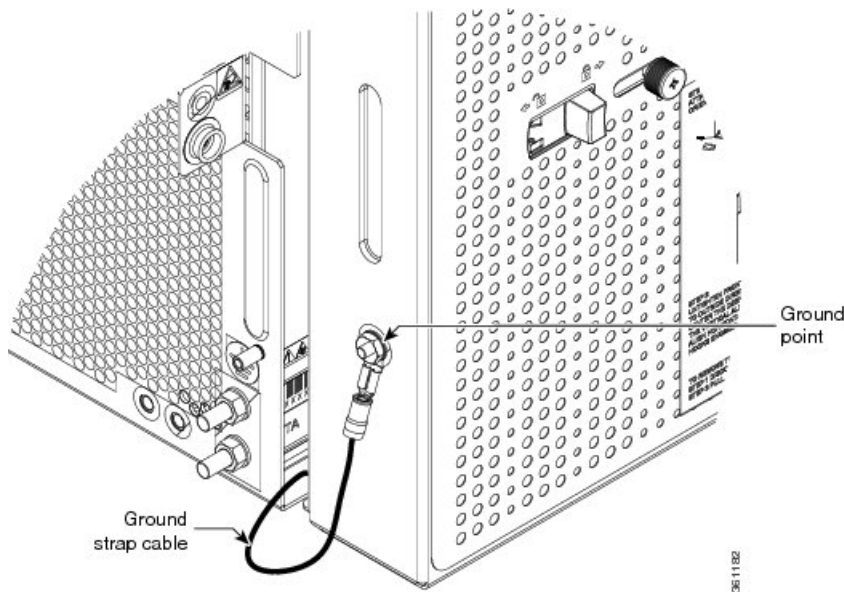

Stop. You have completed this procedure.

NTP-L40 Remove the Deep-Front Panel of the NCS 2006 Shelf

Purpose	This procedure removes the deep-front panel of the NCS 2006 system.
Tools/Equipment	#2 Phillips Dynamometric screwdriver
Prerequisite Procedures	<ul style="list-style-type: none">• NTP-L3 Mounting the NCS 2006 Shelf• NTP-L39 Install the Deep-Front Panel of the NCS 2006 , on page 11• Connect the chassis to the office ground. For detailed instructions on how to ground the chassis, see the Electrostatic Discharge and Grounding Guide for Cisco NCS 2000 Series .
Required/As Needed	Required
Onsite/Remote	Onsite
Security Level	None



Note When the deep front-panel is installed, the total chassis depth is 12.9 inches. The deep front-panel extends from the rack by 1.8 inches.

Procedure

Step 1 Remove the end of the ground strap cable that is connected to the exterior of the deep-front panel.

Figure 19: Removing the end of the ground strap cable

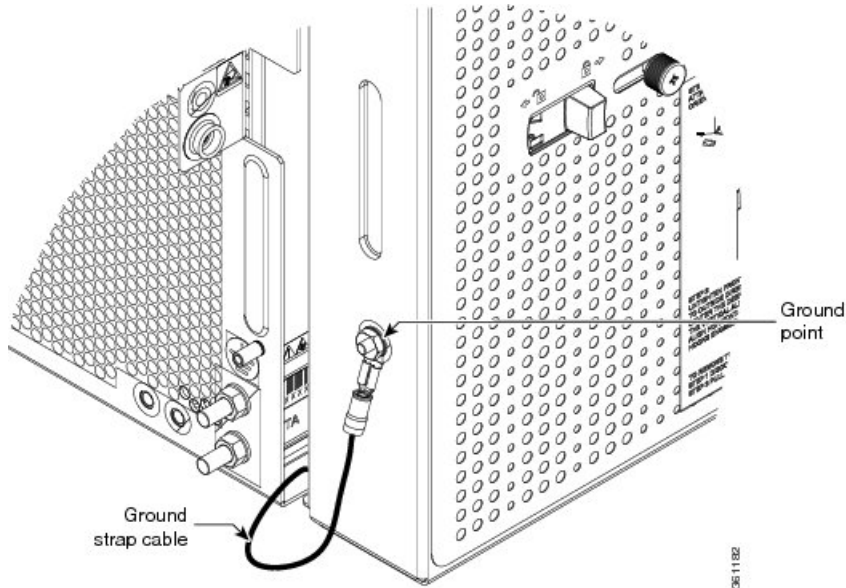

Step 2 Loosen the panel screws to open the deep-front panel.

Step 3 Move the deep-front panel screws in the direction as shown in the figure below to disengage the retention features and the pins from the shelf notches and hinges. See the figure below.

Figure 20: Move the Deep-Front Panel to Disengage

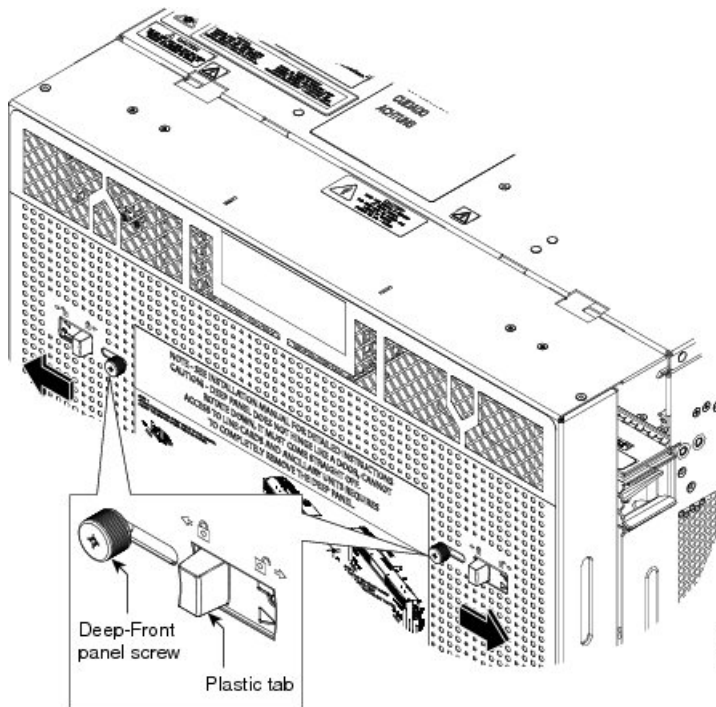

Step 4 Move the deep-front panel away from the shelf. See the figure below.

Figure 21: Move the Deep-Front Panel Away

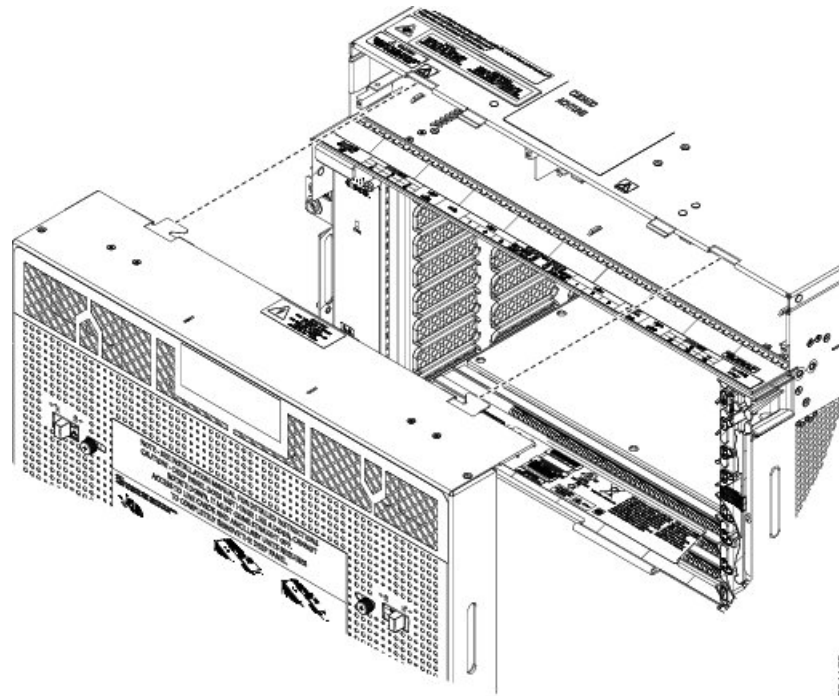

Caution

The deep-front panel does not have a hinge and cannot be rotated like a standard door. Rotating the deep-front panel can damage the deep-front panel, shelf hinges, other devices and cables placed below the NCS 2006 shelf.

Step 5 Remove the ground strap cable from the shelf. See the figure below:

- a) Loosen the ground nut on the shelf.
- b) Remove the lug and tighten the nut on the shelf to a torque value of 11.5 in-lb (1.3 N-m).

Figure 22: Remove the Ground Strap Cable

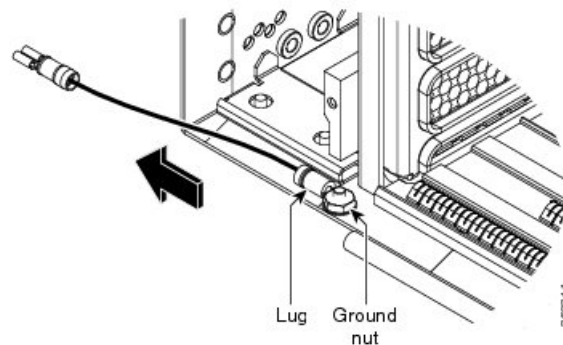

Stop. You have completed this procedure.

External Connection Units

NCS 2006 ECU

The external connection unit (ECU) is a replaceable module placed on top of the NCS 2006 shelf. This ECU module discovers and manages the inventory of the external shelf units. It also handles the multishelf management connections and timing synchronizations. The ECU module available for the NCS 2006 shelf is ECU (PN: NCS2006-ECU=).

The following figure is an example of the ECU module label.

Figure 23: Connector Label for ECU Module



Note The NCS 2006 ECU should not be used when the shelf is powered at –60V DC nominal input voltage.

The following figure shows the NCS 2006 ECU connectors.

Figure 24: Connectors on the NCS 2006 ECU Faceplate



The NCS 2006 ECU is hardware-ready to support IEEE1588v2 PTP, time-of-day (ToD), and pulse-per-second (PPS) inputs. To support high power USB devices, NCS 2006 ECU provides a current of 500 mA to each of the ports.

The external connections present on the NCS 2006 ECU are:

- 12 remote inventory standard USB connections
- 2 BITS-OUT connections (2 subminiature version B [SMB] connectors for ETSI and 4 wire-wrap pins for ANSI)
- 10 MHz IN and OUT and PPS IN and OUT (hardware-ready)
- 2 BITS-IN connections (2 SMB connectors for ETSI and 4 wire-wrap pins for ANSI)
- 6 multishelf connections
- 1 element management system (EMS) connection
- 1 craft terminal connection
- 1 time-of-day (ToD) connection (hardware-ready)
- 2 VoIP or 2 user data channel (UDC) connections, or one each of VoIP and UDC connections
- 1 SCSI with 26 poles for TNC relay contact, including alarm cut-off (ACO) signal and digital I/O (D-I/O) signals (on the left-side connector)
- 1 SCSI with 26 poles for digital I/O signals (on the right-side connector)



Note When no VOIP/UDC port or a single VOIP/UDC port is in use, the NCS 2006 ECU supports 12 USB ports. However, when both VOIP/UDC ports are in use, the NCS 2006 ECU supports only 6 USB ports.

NCS 2006 ECU-S

ECU-S is a new type of ECU introduced for the NCS 2006 in Release 10.5.2. The ECU-S module also discovers and manages the inventory of the external shelf units. It also handles the multishelf management connections and timing synchronizations. The ECU-S module available for the NCS 2006 shelf is NCS2006-ECU-S. The NCS 2006 ECU-S is backward-compatible with Release 10.1, 10.3, and 10.5. However, there is a small difference in the port numbers detected. The details are listed in the section below.



Note The NCS 2006 ECU-S should not be used when the shelf is powered at -60V DC nominal input voltage.

The following figure shows the NCS 2006 ECU-S connectors.

Figure 25: Connectors on the NCS 2006 ECU-S Faceplate

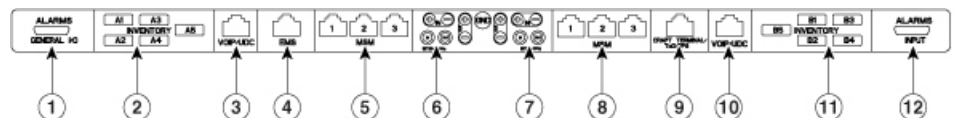

1	1 SCSI with 26 poles for TNC relay contact, including ACO signal and digital I/O signals
2	USB 2.0 ports (Ports A1, A2, A3, A4) and USB 3.0 port (Port A5)
3	VOIP/UDC port (RJ-45 port)
4	EMS port (RJ-45 port)
5	Three MSM ports
6	BITS1 input and output ports
7	BITS2 input and output ports
8	Three MSM ports
9	Craft terminal port
10	VOIP/UDC port (RJ-45 port)
11	USB 2.0 ports (Ports B1, B2, B3, B4) and USB 3.0 port (Port B5)
12	1 SCSI with 26 poles for digital I/O signal

The NCS 2006 ECU-S supports IEEE1588v2 PTP, time-of-day (ToD), and pulse-per-second (PPS) inputs. To support high power USB devices, NCS 2006 ECU-S provides a current of 500 mA to each of the ports. The IMPROPRMVL alarm is raised in CTC when the ECU-S is removed from the NCS 2006 shelf.



Note When NCS 2006 is pre-provisioned, or plugged in without the ECU-S unit, by default, CTC uses the ECU module with the 12 USB 2.0 ports.

The fiber shuffle unit or the NCS2K-MF-6RU unit, which can be used to interface 14 single slot passive optical modules can be connected to the NCS 2006 ECU-S using the USB 3.0 port.

The MPO-fan-out unit or the NCS2K-MF10-6RU unit, which can be used to interface 10 double slot passive optical modules can be connected to the NCS 2006 ECU-S using the USB 3.0 port.

The external connections present on the NCS 2006 ECU-S are:

- 2 USB 3.0 connections
 - The USB 3.0 port on the left of the faceplate is detected as A5.
 - The USB 3.0 port on the right of the faceplate is detected as B5.
- 8 USB 2.0 connections
 - 4 USB 2.0 on the left of the faceplate are detected as A1, A2, A3, A4.
 - 4 USB 2.0 ports on the right of the faceplate are detected as B1, B2, B3, B4. In Release 10.1, 10.3, and 10.5, these ports are detected as A5, A6, B1, B2 respectively.
- 2 BITS-OUT connections (2 subminiature version B [SMB] connectors for ETSI and 4 wire-wrap pins for ANSI)
- 10 MHz IN and OUT and PPS IN and OUT (hardware-ready)
- 2 BITS-IN connections (2 SMB connectors for ETSI and 4 wire-wrap pins for ANSI)
- 6 multishelf connections
- 1 element management system (EMS) connection
- 1 craft terminal connection
- 1 time-of-day (ToD) connection (hardware-ready)
- 2 VoIP or 2 user data channel (UDC) connections, or one each of VoIP and UDC connections
- 1 SCSI with 26 poles for TNC relay contact, including alarm cut-off (ACO) signal and digital I/O (D-I/O) signals (on the left-side connector)
- 1 SCSI with 26 poles for digital I/O signals (on the right-side connector)

NCS 2006 ECU60-S

ECU60-S is a new type of ECU-S introduced for the NCS 2006 when the shelf is powered at -60 VDC nominal input voltage. The ECU60-S module available for the NCS 2006 shelf is NCS2006-ECU60-S=.

The following figure shows the NCS 2006 ECU60-S connectors.

Figure 26: Connectors on the NCS 2006 ECU60-S Faceplate

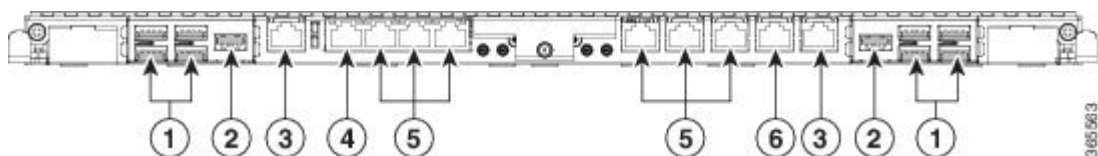

1	USB 2.0 ports (Ports 1 through 4 and ports 7 through 10)
---	--

2	USB 3.0 ports (Ports 5 and 11)
3	VOIP/UDC ports (RJ-45 port)
4	EMS port (RJ-45 port)
5	MSM ports
6	Craft terminal connection

The NCS 2006 ECU60-S supports IEEE1588v2 PTP, time-of-day (ToD), and pulse-per-second (PPS) inputs. The IMPROPRMVL alarm is raised in CTC when the ECU60-S is removed from the NCS 2006 shelf.



Note When NCS 2006 is pre-provisioned, or plugged in without the ECU60-S unit, by default, CTC uses the ECU module with the 12 USB 2.0 ports.

The fiber shuffle unit or the NCS2K-MF-6RU unit, which can be used to interface 14 single slot passive optical modules can be connected to the NCS 2006 ECU60-S using the USB 3.0 port.

The MPO-fan-out unit or the NCS2K-MF10-6RU unit, which can be used to interface 10 double slot passive optical modules can be connected to the NCS 2006 ECU60-S using the USB 3.0 port.

The NCS 2006 ECU60-S is backward-compatible with releases prior to 10.5.2.

The external connections present on the NCS 2006 ECU60-S are:

- 2 USB 3.0 connections
 - The USB 3.0 port on the left of the faceplate is detected as A5.
 - The USB 3.0 port on the right of the faceplate is detected as B5.
- 8 USB 2.0 connections
 - 4 USB 2.0 on the left of the faceplate are detected as A1, A2, A3, A4.
 - 4 USB 2.0 ports on the right of the faceplate are detected as B1, B2, B3, B4. In releases prior to 10.5.2, these ports are detected as A5, A6, B1, B2 respectively.
- 2 BITS-OUT connections (2 subminiature version B [SMB] connectors for ETSI and 4 wire-wrap pins for ANSI)
- 10 MHz IN and OUT and PPS IN and OUT (hardware-ready)
- 2 BITS-IN connections (2 SMB connectors for ETSI and 4 wire-wrap pins for ANSI)
- 6 multishelf connections
- 1 element management system (EMS) connection
- 1 craft terminal connection
- 1 time-of-day (ToD) connection (hardware-ready)
- 2 VoIP or 2 user data channel (UDC) connections, or one each of VoIP and UDC connections



Note POE functionality is not available for the VOIP ports.

You can upgrade to the NCS2006 ECU60-S from an older ECU (ECU/ECU-2/ECU-S) in the NCS 2006 shelf. For more information, see [NTP-L66 Upgrading to NCS 2006 ECU60-S Module, on page 28](#).

Alarm Connectors

The NCS 2006 ECU and ECU-S modules have two SCSI alarm connectors that are used to connect NCS 2006 to support external alarms. The alarm connectors provide dry alarm contacts and are similar to the AIC-I card of the ONS 15454 M12. shelf. The left alarm connector is used for TNC and TNCE relay contact, including Alarm Cut Off (ACO) signal and Digital Input/Output (D-I/O) signals. The right alarm connector is used for Digital Input/Output (D-I/O) signals. To export alarms from the NCS 2006 shelf to a third party device, use the output pins of either the right alarm connector or the left alarm connector.

When external controls are not provisioned, 14 external input alarms are available. Input alarm 11 and input alarm 12 are available on the left side connector; input alarm 13 and input alarm 14 are available on the right side connector.

When external controls are provisioned, only 10 external input alarms are available.



Note In a multishelf configuration, alarms on the subtended shelves cannot be extended through the node controller.

See Table 6-2 and Table 6-3 for pin details of the alarm connectors.



Note ECU60-S does not support alarm connections.

Passive Unit Inventory Interfaces

The passive unit inventory interfaces (USB ports) are used to retrieve inventory information from passive devices such as fiber trays, FBG DCU, patch panels, passive multiplexer or demultiplexer, and so on. There are 12 USB ports on the NCS 2006 ECU module. The inventory details are displayed in the Inventory tab in CTC.

The USB 3.0 port delivers power to the NCS2K-MF-6RU or the NCS2K-MF10-6RU unit when they are connected to the NCS 2006 ECU-S.



Note The 12 passive inventory ports on the NCS 2006 ECU module are labeled 1 to 12. However, CTC represents the passive inventory ports as USBP_SIDE_PORT, where SIDE can be A or B, and PORT can be any value from 1 to 12. For example, Port 1 on the left side of the ECU module is represented as USBP_A_1 and Port 1 on the right side of the NCS 2006 ECU module is represented as USBP_B_1. The left side of the NCS 2006 ECU module is Side A and the right side of the NCS 2006 ECU module is Side B.



Note The 8 passive inventory USB 2.0 ports on the NCS 2006 ECU-S module are labeled 1 through 4 and 7 through 10. The USB 3.0 port on the left of the faceplate is detected as A5. The USB 3.0 port on the right of the faceplate is detected as B5. However, CTC represents the passive inventory ports as USBP_SIDE_PORT, where SIDE can be A or B, and PORT can be any value from 1 to 5. For example, Port 1 on the left side of the ECU-S module is represented as USBP_A_1 and Port 1 on the right side of the NCS 2006 ECU-S module is represented as USBP_B_1. The left side of the NCS 2006 ECU-S module is Side A and the right side of the NCS 2006 ECU-S module is Side B.

VoIP or UDC

VoIP or UDC is an RJ45 port that can be configured to support UDC or VoIP service on an NCS 2006 shelf. There are two VoIP or UDC ports on the NCS 2006 ECU and ECU-S modules. The VoIP or UDC port on the left side is connected to the TNC or TNCE card in Slot 1 and the port on the right side is connected to the TNC or TNCE card in Slot 8. The VoIP or UDC port also supports Power over Ethernet for connecting VoIP equipments.



Note POE functionality is not available for the VOIP ports of ECU60-S.

MSM

The multishelf management (MSM) port is an RJ-45 port that is used to connect the NCS 2006 shelf to other NCS 2006 or NCS 2006 shelves that are a part of the multishelf configuration. There are six MSM ports on the NCS 2006 ECU and ECU-S modules—three ports on the left side and three ports on the right side. The MSM ports on the left side correspond to the TNC/TNCE/TSC/TSCE card in Slot 1, and those on the right side correspond to the TNC/TNCE/TSC/TSCE card in Slot 8. Three MSM ports are used as working ports, and the remaining three are used as standby ports.

Timing Connections

The NCS 2006 ECU and ECU-S modules have four Building Integrated Timing Supply (BITS) connections that support both ETSI and ANSI connections. There are two BITS-IN and two BITS-OUT connections that can either be SMB connectors for ETSI connection or wire-wrap pins for ANSI connection, based on customer requirements. The BITS-IN ports receive input from third-party external sources called Synchronization Supply Unit (SSU) to synchronize the timing of the NCS 2006 shelf. The BITS-OUT ports provide output to external devices (other Cisco or third-party shelves) to synchronize the timing signals with the NCS 2006 shelf.



Note For timing connection, use 100 ohm shielded BITS clock cable pair #22 or #24 AWG (0.51 mm² [0.020 inch] or 0.64 mm² [0.0252 inch]), twisted-pair T1-type.



Note See Telcordia SR-NWT-002224 for rules about provisioning timing references.

NTP-L8 Install the NCS 2006 ECU and ECU-S Modules

Purpose	This procedure installs the ECU and ECU-S modules (ECU, ECU2, ECU-S, or ECU60-S) in the NCS 2006 shelf.
Tools/Equipment	Small slot-head screwdriver

Prerequisite Procedures	<ul style="list-style-type: none"> • NTP-L2 Mounting the Brackets in ANSI Configuration. • NTP-L5 Opening and Removing the Standard Door of the NCS 2006 Shelf , on page 7. • Connect the chassis to the office ground. For detailed instructions on how to ground the chassis, see the Electrostatic Discharge and Grounding Guide for Cisco NCS 2000 Series .
Required/As Needed	Required
Onsite/Remote	Onsite
Security Level	None



Caution The intra-building port(s) of the equipment or subassembly is suitable for connection to intra-building or unexposed wiring or cabling only. The intra-building port(s) of the equipment or subassembly **MUST NOT** metalically connect to interfaces that connect to the OSP or its wiring. These interfaces are designed for use as intra-building interfaces only (Type 2 or Type 4 ports as described in GR-1089-CORE, Issue 5) and require isolation from the exposed OSP cabling. The addition of Primary Protectors is not sufficient protection in order to connect these interfaces metalically to OSP wiring. Statement 7005



Warning To comply with the Telcordia GR-1089 NEBS standard for electromagnetic compatibility and safety, connect the serial high-speed WAN interface ports only to intra-building or unexposed wiring or cable. The intrabuilding cable must be shielded and the shield must be grounded at both ends. The intra-building port(s) of the equipment or subassembly must not be metalically connected to interfaces that connect to the OSP or its wiring. These interfaces are designed for use as intra-building interfaces only (Type 2 or Type 4 ports as described in GR-1089-CORE) and require isolation from the exposed OSP cabling. The addition of Primary Protectors is not sufficient protection in order to connect these interfaces metalically to OSP wiring. Statement 7003



Warning The intra-building port(s) of the equipment or subassembly is suitable for connection to intra-building or unexposed wiring or cabling only. The intra-building port(s) of the equipment or subassembly **MUST NOT** metalically connect to interfaces that connect to the OSP or its wiring. These interfaces are designed for use as intra-building interfaces only (Type 2 or Type 4 ports as described in GR-1089-CORE, Issue 5) and require isolation from the exposed OSP cabling. The addition of Primary Protectors is not sufficient protection in order to connect these interfaces metalically to OSP wiring. Statement 7018



Warning Voltages that present a shock hazard may exist on Power over Ethernet (PoE) circuits if interconnections are made using uninsulated exposed metal contacts, conductors, or terminals. Avoid using such interconnection methods, unless the exposed metal parts are located within a restricted access location and users and service people who are authorized within the restricted access location are made aware of the hazard. A restricted access area can be accessed only through the use of a special tool, lock and key or other means of security. Statement 1072



Caution Always use the supplied ESD wristband when working [Electrostatic Discharge and Grounding Guide for Cisco NCS 2000 Series](#).



Note If the USB device connected to the NCS 2006 ECU or ECU-S module is not detected when the NCS 2006 shelf assembly is powered on, plug out (remove) the NCS 2006 ECU or ECU-S module and insert it again.

Procedure

- Step 1** Insert the NCS 2006 ECU or ECU-S module in the central slot of the chassis (see the figure below).
- Step 2** Push the NCS 2006 ECU or ECU-S module such that the backplane connector is completely engaged and the faceplate of the NCS 2006 ECU or ECU-S module aligns with the edge of the chassis side wall.
- Step 3** Tighten the screws to a torque value of 4 in-lb (0.45 N-m).

Stop. You have completed this procedure.

Figure 27: Installing the NCS 2006 ECU module

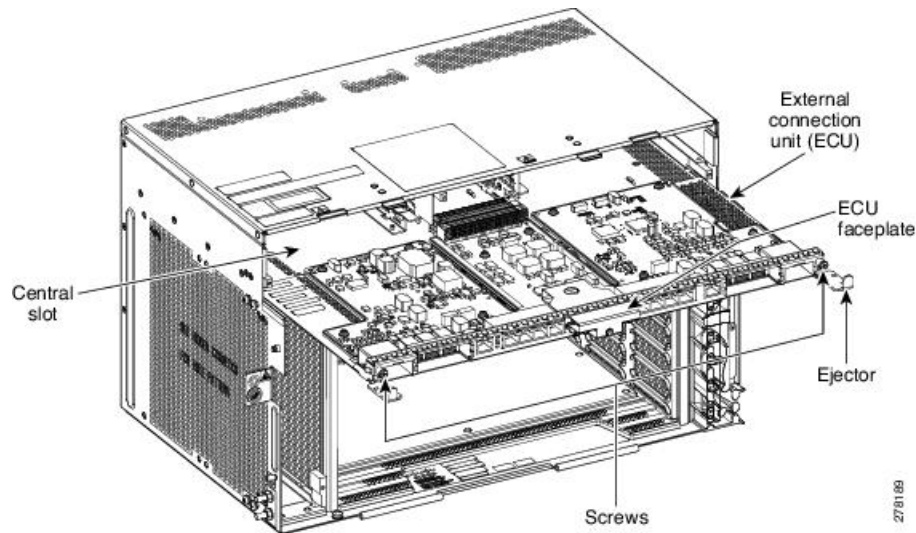

The following figure shows the ECU module installed in the NCS 2006 shelf.

Figure 28: NCS 2006 Shelf with ECU module Installed

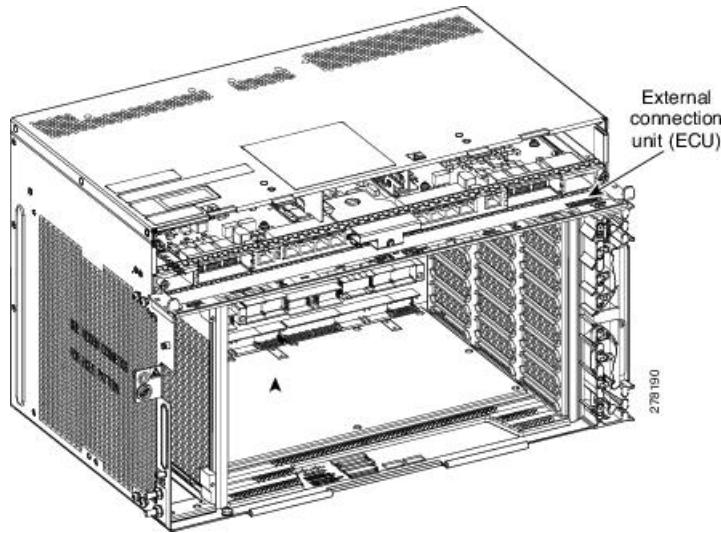

NTP-L66 Upgrading to NCS 2006 ECU60-S Module



Caution Always use the supplied ESD wristband when working with a powered NCS 2006. For detailed instructions on how to wear the ESD wristband, see the [Electrostatic Discharge and Grounding Guide for Cisco NCS 2000 Series](#).



Note Do not replace the NCS2006-DC20, or NCS2006-DC40 power modules with the NCS2006-DC V03 power module if the NCS2006 shelf is consuming more than 960 W of power. Refer to table A-4 to ascertain the power consumption of the shelf.

Procedure

- Step 1** Power down the NCS 2006 shelf.
- Step 2** Remove the NCS2006-DC20 or NCS2006-DC40 DC power module from the NCS 2006 shelf.
- Step 3** Install the NCS2006-DC V03 DC Power Module in the NCS 2006 shelf as described in [DLP-L15 Installing the DC Power Module in the NCS 2006 Shelf, on page 33](#).
- Step 4** Remove the ECU module (ECU/ECU-2/ECU-S) from the NCS 2006 shelf.
- Step 5** Install the ECU60-S module in the NCS 2006 shelf as described in [NTP-L8 Install the NCS 2006 ECU and ECU-S Modules, on page 25](#).

- Step 6** Power on the NCS2006-DC V03 power module as described in [NTP-L12 Installing Power and Ground to the NCS 2006 Shelf](#).

Stop. You have completed this procedure.

Power Modules

The NCS 2006 system contains pluggable and redundant power modules for AC and DC power. The AC and DC power modules cannot be used simultaneously to power the NCS 2006 system. Before installing the power module, verify the position of the mechanical locking system on the rear side of the chassis. To insert the AC power module, the screw must be close to the AC silk-screen text; to insert the DC power module the screw must be close to the DC silk-screen text.

AC Power Module

The NCS 2006 system can be powered by redundant AC power lines

The AC power module converts the AC-input current to DC-output current. There are two separate AC power modules, however a single AC power module can power the entire NCS 2006 system.

Each AC power module has one AC single-phase 3 poles (line L, Neutral N, and Protective Earth PE) input connector.

The AC power module has a dual color (red and green) LED on the faceplate. When the AC power line is not connected, the LED is OFF. Green LED indicates that the AC power line is connected and the power module is functioning properly. Red LED indicates that the AC power line is connected but an alarm is present due to a secondary fuse break (48 V DC) or AC module fan failure. The shelf controller card controls the conditions that result in triggering the LEDs. The LED can be overwritten by the shelf controller card (TNC, TNCE, TSC, or TSCE) in all the three states (OFF/red/green). The AC power module supports the lamp test procedure. The AC power module has fans that are directly powered by the module. The fans cool the module and guarantees proper operation across the complete operating temperature or output power range. These fans contain replaceable air-filters

DC Power Module

The NCS 2006 system can be powered by redundant DC power modules or a single DC power module. The supported DC power modules on the NCS 2006 shelf are NCS2006-DC, NCS2006-DC20, and NCS2006-DC40. The DC power module draws power from the batteries to turn on the NCS 2006 shelf.



Note When the NCS 2006 shelf is powered at -60 VDC (nominal), only the TNC, OPT-AMP-C, OPT-AMP-17-C, OPT-EDFA-17, OPT-EDFA-24, 17 SMR9 FS, 24 SMR9 FS, 34 SMR9 FS, SMR20 FS, SMR20 FS CV, 12-AD-FS, 16-AD-FS, 100GS-CK-LC, and MR-MXP cards, and the NCS2006-ECU-60 can be installed.

The NCS2006-DC40 power module is required to accommodate up to four 100GS-CK-LC cards in a NCS 2006 shelf.

For the NCS2006-DC20 power module, the power consumption of the NCS 2006 shelf (including ancillaries, controller cards, and line cards) is limited to 960 W. A new line card will not boot up when it is installed in the NCS 2006 shelf, if it causes the power consumption of the shelf to exceed 960 W. The PWR-CON-LMT alarm is raised in the Alarms tab in CTC when the installation or pre-provisioning of a card causes the power consumption to exceed the limit of 960 W.

For the NCS2006-DC40 power module, the power consumption of the NCS 2006 shelf (including ancillaries, controller cards, and line cards) is limited to 1920 W. A new line card will not boot up when it is installed in the NCS 2006 shelf, if it causes the power consumption of the shelf to exceed 1920 W. The PWR-CON-LMT alarm is raised in the Alarms tab in CTC when the installation or pre-provisioning of a card causes the power consumption to exceed the limit of 1920 W.



Note The total power consumption of the shelf is calculated by the controller card and displayed in CTC in the Provisioning > Power Monitor tab. For details about power calculation, see the .

Each DC power module has:

- One input battery connector (three poles) —VBAT, VRET, and FGnd for ETSI installation
- Terminal block connector with VBAT and VRET for installation

The DC power module has a dual color (red and green) LED on the faceplate. When the battery is not connected, the LED is OFF. Green LED indicates that the battery is connected and the power module functions properly. Red LED indicates that the battery is connected but an alarm is present due to secondary fuse break (48 V). The DC power module does not support the lamp test procedure.

Changing the DC Power Module

It is possible to change the power modules from NCS2006-DC20 to NCS2006-DC and vice-versa, without powering down the NCS 2006 system. While changing the power modules, ensure that only one power module is replaced at a time and the other power module continues to supply power to the shelf. However, during regular operation of the node, the NCS 2006 shelf must have the NCS2006-DC20, NCS2006-DC, or NCS2006-DC40 power module. See [DLP-L16 Replacing NCS2006-DC With NCS2006-DC20 Power Module, on page 36](#) and [DLP-L17 Replacing NCS2006-DC20 With NCS2006-DC Power Module, on page 37](#) for changing the power modules.

Power Filler Module

For redundant power supplies, two AC or DC power modules can be installed in Slot A and Slot B of the NS 2006 shelf. However, only one power module can sustain the functioning of the entire NCS 2006 system. In that case, insert a power filler module in the empty slot.

NTP-L9 Installing the Power Modules in the NCS 2006 Shelf

Purpose	This procedure installs the power modules in the NCS 2006 system.
Tools/Equipment	#2 Phillips screwdriver

Prerequisite Procedures	<ul style="list-style-type: none"> • NTP-L2 Mounting the Brackets in ANSI Configuration. • NTP-L5 Opening and Removing the Standard Door of the NCS 2006 Shelf , on page 7. • Connect the chassis to the office ground. For detailed instructions on how to ground the chassis, see the Electrostatic Discharge and Grounding Guide for Cisco NCS 2000 Series .
Required/As Needed	Required
Onsite/Remote	Onsite
Security Level	None



Warning The plug-socket combination must be accessible at all times because it serves as the main disconnecting device. Statement 1019

Procedure

- Step 1** Complete the necessary task as applicable:
- [DLP-L14 Installing the AC Power Module in the NCS 2006 Shelf, on page 31](#)
 - [DLP-L15 Installing the DC Power Module in the NCS 2006 Shelf, on page 33](#)
 - [DLP-L16 Replacing NCS2006-DC With NCS2006-DC20 Power Module, on page 36](#)
 - [DLP-L17 Replacing NCS2006-DC20 With NCS2006-DC Power Module, on page 37](#)
- Step 2** Complete [NTP-L12 Installing Power and Ground to the NCS 2006 Shelf](#).
- Stop. You have completed this procedure.**

DLP-L14 Installing the AC Power Module in the NCS 2006 Shelf

Purpose	This task installs the NCS2006-AC or 15454-M6-AC2 power module in the NCS 2006 system.
Tools/Equipment	#2 Phillips screwdriver
Prerequisite Procedures	<ul style="list-style-type: none"> • NTP-L2 Mounting the Brackets in ANSI Configuration. • NTP-L5 Opening and Removing the Standard Door of the NCS 2006 Shelf , on page 7. • Connect the chassis to the office ground. For detailed instructions on how to ground the chassis, see the Electrostatic Discharge and Grounding Guide for Cisco NCS 2000 Series .

Required/As Needed	Required
Onsite/Remote	Onsite
Security Level	None



Tip Insert the AC power module in Slot A or Slot B, or both (see the figure below).



Note While inserting the AC power module, apply insertion force only above the hook and not on the air filter (see the figure below).

Figure 29: Installing the AC Power Modules

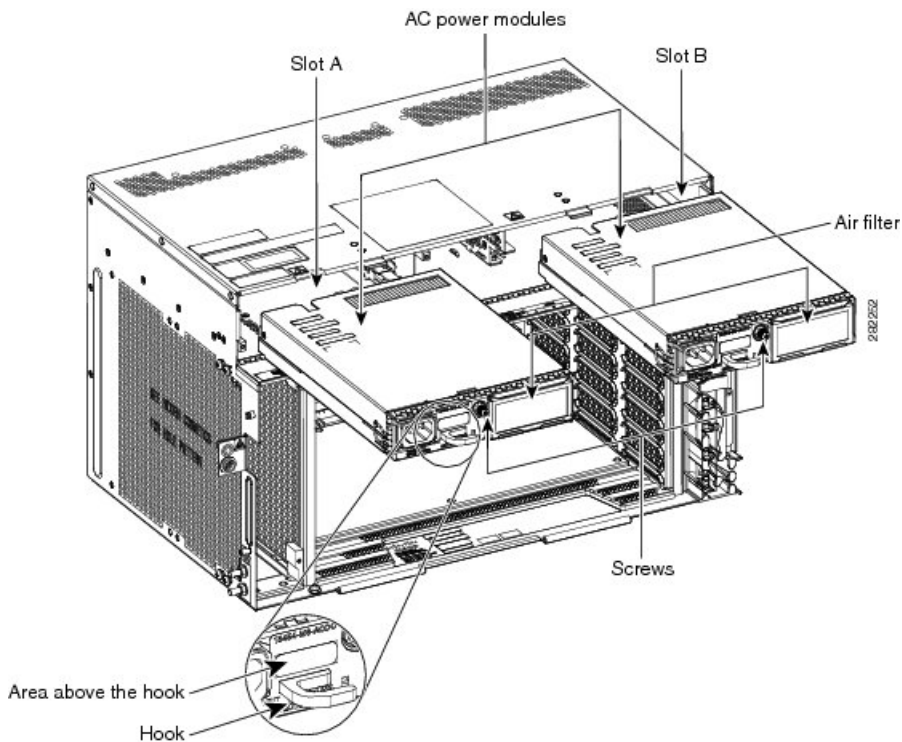

Procedure

- Step 1** Plug the AC power module completely into the chassis.
- Step 2** Tighten the screw to a torque value of 4 in-lb (0.45 N-m) to lock the power module in the chassis (see the figure below).

Note

For redundant power supplies, two AC power modules can be installed in Slot A and Slot B. However, only one power module can sustain the functioning of the entire NCS 2006 system. In that case, insert a power filler module in the empty slot (for example, see the figure below).

Figure 30: AC Power Modules Installed in the NCS 2006 Shelf

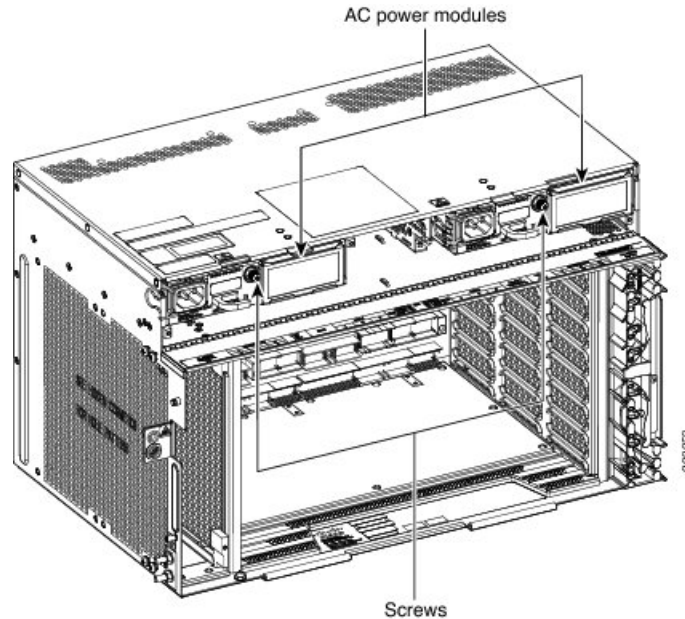

Step 3 Return to your originating procedure (NTP).

DLP-L15 Installing the DC Power Module in the NCS 2006 Shelf

Purpose	This procedure installs the NCS2006-DC, NCS2006-DC20, or NCS2006-DC40 DC power module in the NCS2006 system.
Tools/Equipment	#2 Phillips Dynamometric screwdriver
Prerequisite Procedures	<ul style="list-style-type: none"> • NTP-L2 Mounting the Brackets in ANSI Configuration. • NTP-L5 Opening and Removing the Standard Door of the NCS 2006 Shelf, on page 7. • Connect the chassis to the office ground. For detailed instructions on how to ground the chassis, see the Electrostatic Discharge and Grounding Guide for Cisco NCS 2000 Series.
Required/As Needed	Required
Onsite/Remote	Onsite
Security Level	None



Caution While changing the power modules from NCS2006-DC20 to NCS2006-DC and vice-versa, the NCS 2006 shelf can temporarily work with both NCS2006-DC and NCS2006-DC20 power modules installed. However, during regular operation, the shelf must either have the NCS2006-DC or NCS2006-DC20 power module, but not both.

Procedure

Step 1 Insert the DC power module in Slot A or Slot B (or both) (see the figure below).

Figure 31: Installing the DC power module

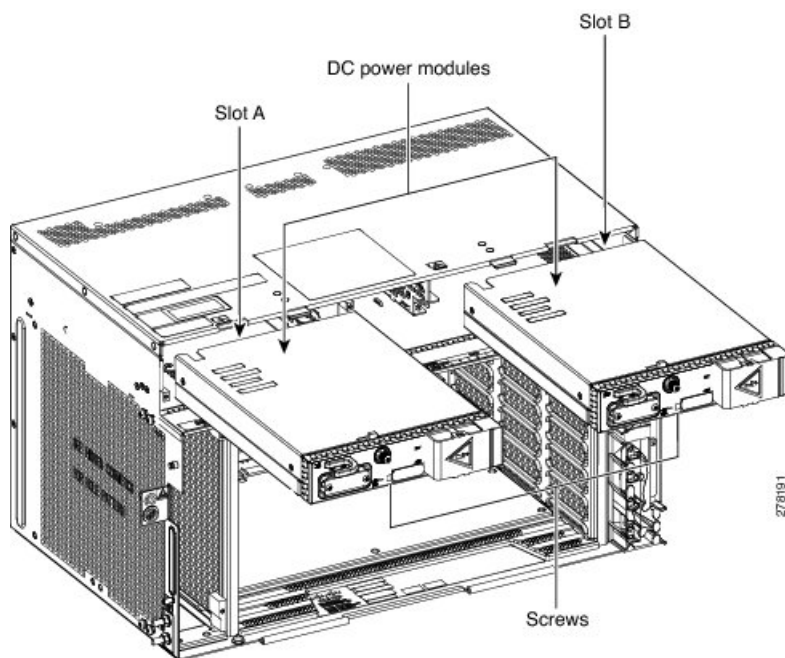

Step 2 Plug the DC power module completely into the chassis.

Step 3 Tighten the screw to a torque value of 4 in-lb (0.45 N-m) to lock the power module in the chassis (see Figure 4-30).

Figure 32: DC Power Modules Installed in the NCS 2006 Shelf

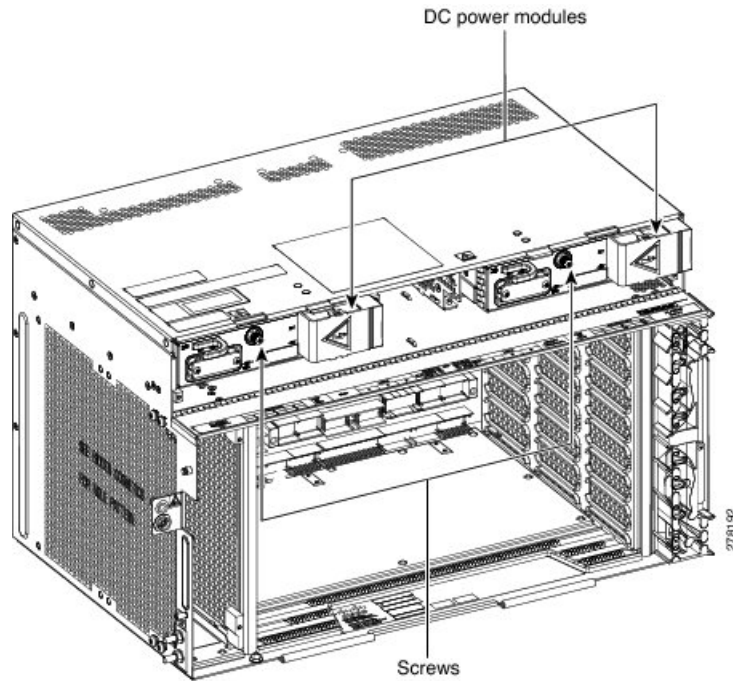

Note

For redundant power supplies, two DC power modules can be installed in Slot A and Slot B. However, only one power module can sustain the functioning of the entire NCS 2006 system. In that case, insert a power filler module in the empty slot.

The following figure shows a DC power module installed in Slot A and a power filler module installed in Slot B.

Figure 33: Installing a Power Filler Module

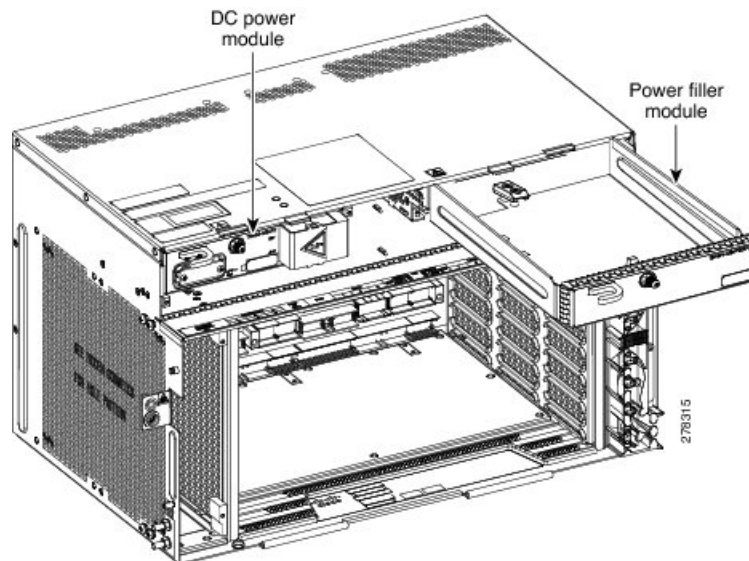

Step 4 Return to your originating procedure (NTP).

Note

When the NCS 2006 shelf is powered at –60 VDC (nominal), only the TNC, OPT-AMP-C, OPT-AMP-17-C, OPT-EDFA-17, and OPT-EDFA-24 cards, and the NCS2006-ECU-60 can be installed.

DLP-L16 Replacing NCS2006-DC With NCS2006-DC20 Power Module

Purpose	This procedure replaces the NCS2006-DC with NCS2006-DC20 power module.
Tools/Equipment	#2 Phillips Dynamometric screwdriver
Prerequisite Procedures	NTP-L5 Opening and Removing the Standard Door of the NCS 2006 Shelf , on page 7
Required/As Needed	Required
Onsite/Remote	Onsite
Security Level	None



Note The procedure to replace the NCS2006-DC power module with NCS2006-DC40 power module is the same as this procedure. The NCS2006-DC40 power module uses NCS2006-DCCBL2-L= and NCS2006-DCCBL2-R= cables.



Note Do not replace the NCS2006-DC with the NCS2006-DC20 power module if the NCS2006 shelf is consuming more than 960 W of power. Refer to table A-4 to ascertain the power consumption of the shelf.



Caution While changing the power modules from NCS2006-DC20 to NCS2006-DC and vice-versa, the NCS 2006 shelf can temporarily work with both NCS2006-DC and NCS2006-DC20 power modules installed. However, during regular operation, the shelf must either have the NCS2006-DC or NCS2006-DC20 power module, but not both.



Caution Always use the supplied ESD wristband when working with a powered NCS 2006. For detailed instructions on how to wear the ESD wristband, see the [Electrostatic Discharge and Grounding Guide for Cisco NCS 2000 Series](#) .

Procedure

- Step 1** Disconnect the power source and remove the power connections from the standby power module (installed in slot B).
- Step 2** Unscrew the holding screw that secures the NCS2006-DC power module.
- Step 3** Pull the NCS2006-DC power module clear from the NCS 2006 chassis.
- Step 4** Install the NCS2006-DC20 power module as described in the [DLP-L15 Installing the DC Power Module in the NCS 2006 Shelf, on page 33](#).
- Step 5** Install power on the NCS2006-DC20 power module as described in the [NTP-L12 Installing Power and Ground to the NCS 2006 Shelf](#).

Note

While replacing the power modules, do not provision or install any line cards when the NCS 2006 chassis is in the mixed power mode. Card provisioning and installation must be done only after both the slots have the same type of power modules.

- Step 6** Perform the Steps 1 to 5 for the active power module (installed in slot A).

Note

To ensure that the controller card is calculating the shelf power consumption correctly, reset the controller card. For details about performing card reset, see the “NTP-G106 Reset Cards Using CTC” procedure in the *Cisco NCS 2000 Series Network Configuration Guide*. If the power consumption of the shelf is exceeding 960 W, the PWR-CON-LMT alarm is raised. Either revert to the NCS2006-DC power module or remove and deprovision the existing line cards to reduce the load.

- Step 7** Return to your originating procedure (NTP).

DLP-L17 Replacing NCS2006-DC20 With NCS2006-DC Power Module

Purpose	This procedure replaces the NCS2006-DC20 with NCS2006-DC power module.
Tools/Equipment	#2 Phillips Dynamometric screwdriver
Prerequisite Procedures	NTP-L5 Opening and Removing the Standard Door of the NCS 2006 Shelf , on page 7.
Required/As Needed	Required
Onsite/Remote	Onsite
Security Level	None



- Note** The procedure to replace the NCS2006-DC20 power module with NCS2006-DC40 power module is the same as this procedure. The NCS2006-DC40 power module uses NCS2006-DCCBL2-L= and NCS2006-DCCBL2-R= cables.



Caution While changing the power modules from NCS2006-DC20 to NCS2006-DC and vice-versa, the NCS 2006 shelf can temporarily work with both NCS2006-DC and NCS2006-DC20 power modules installed. However, during regular operation, the shelf must either have the NCS2006-DC or NCS2006-DC20 power module, but not both.



Caution Always use the supplied ESD wristband when working with a powered NCS 2006. For detailed instructions on how to wear the ESD wristband, see the [Electrostatic Discharge and Grounding Guide for Cisco NCS 2000 Series](#).

Procedure

-
- Step 1** Disconnect the power source and remove the power connections from the standby power module (installed in slot B).
 - Step 2** Unscrew the holding screw that secures the NCS2006-DC20 power module.
 - Step 3** Pull the NCS2006-DC20 power module clear from the NCS2006 chassis.
 - Step 4** Install the NCS2006-DC power module as described in the [DLP-L15 Installing the DC Power Module in the NCS 2006 Shelf](#), on page 33.
 - Step 5** Install power on the NCS2006-DC power module as described in the [NTP-L12 Installing Power and Ground to the NCS 2006 Shelf](#).

Note

While replacing the power modules, do not provision or install any line cards when the NCS 2006 chassis is in the mixed power mode. Card provisioning and installation must be done only after both the slots have the same type of power modules.

- Step 6** Perform Steps 1 to 5 for the active power module (installed in slot A).
 - Step 7** Return to your originating procedure (NTP).
-

LCD Unit

The LCD unit consists of an LCD display panel, push button, and shelf-level LED indicators on the NCS 2006 system. A backup flash memory is fitted into the LCD unit to support the database (DB) and image backup in the operation of the NCS 2006.

The shelf controller card (TSC, TSCE, TNC, or TNCE) powers the 16 x 2 character LCD screen. The LCD screen displays the shelf name, shelf IP address, and software version currently used. The LCD screen also provides slot-level and port-level information of all card slots, including the number of critical, major, and minor alarms. The display contrast is automatically adjusted for a clearer view. The three accessible push buttons (SLOT, STATUS, and PORT) on the LCD unit are used to set parameters at the slot-level and port-level. There are three alarm LEDs (CRIT, MAJ, and MIN) on the LCD unit that indicate whether a critical, major, or minor alarm is present anywhere on the NCS 2006 shelf. The shelf controller card controls the conditions that result in triggering the LEDs. The LEDs can be overwritten by the shelf controller card (TNC, TNCE,

TSC, or TSCE) in all the three states (OFF/red/green). The LCD unit supports the lamp test procedure and the LEDs changes its color or state.



Note If the LCD unit is removed from the shelf, wait for at least 5 seconds before plugging it back into the shelf. In the event the LCD display appears blank, remove the unit from the shelf, wait for at least 5 seconds and reinsert the unit into the shelf.

The LCD module must be present in the NCS 2006 shelf to:

- Provision the ECU module, fan-tray assembly, or power modules.
- Retrieve alarms from the ECU module, fan-tray assembly, or power modules.

NTP-L10 Installing the LCD Module in the NCS 2006 Shelf

Purpose	This procedure installs the LCD module in the NCS 2006 system.
Tools/Equipment	Small slot-head screwdriver
Prerequisite Procedures	<ul style="list-style-type: none"> • NTP-L2 Mounting the Brackets in ANSI Configuration. • NTP-L5 Opening and Removing the Standard Door of the NCS 2006 Shelf, on page 7. • Connect the chassis to the office ground. For detailed instructions on how to ground the chassis, see the Electrostatic Discharge and Grounding Guide for Cisco NCS 2000 Series.
Required/As Needed	Required
Onsite/Remote	Onsite
Security Level	None



Note If the LCD unit is removed from the shelf, wait for at least 5 seconds before plugging it back into the shelf. In the event the LCD display appears blank, remove the unit from the shelf, wait for at least 5 seconds and reinsert the unit into the shelf.

Procedure

- Step 1** Insert the LCD module in the central slot (between the power slots) of the chassis (see the figure below).
- Step 2** Push the LCD module into the chassis such that the backplane connector is completely engaged (see the figure below).

Figure 34: Installing the LCD Module

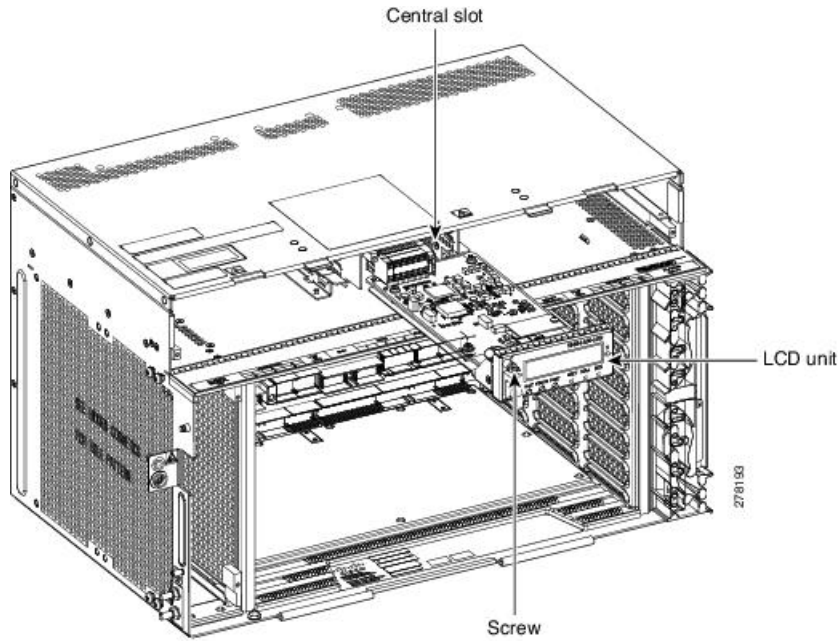

Step 3 Tighten the screw to a torque value of 4 in-lb (0.45 N-m) to lock the unit (see the figure below).

Figure 35: LCD Module Installed in the NCS 2006 Shelf

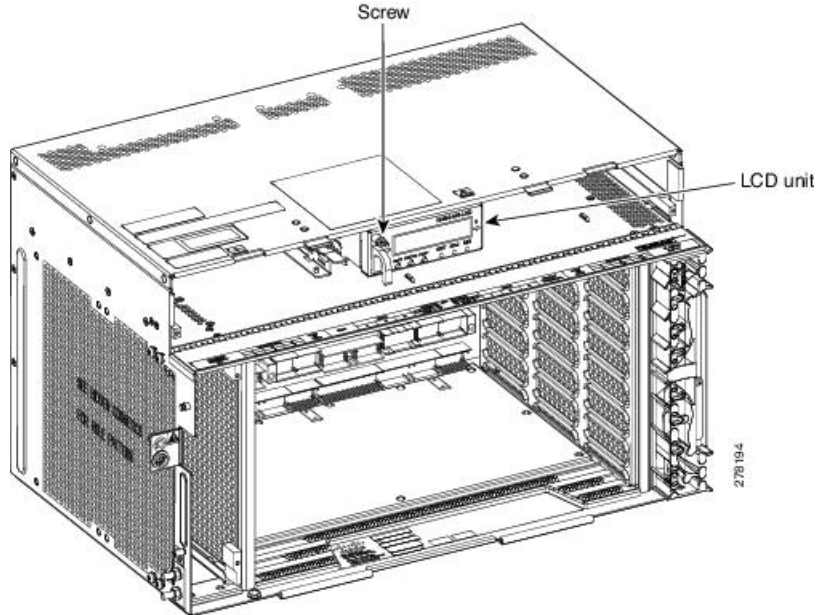

Stop. You have completed this procedure.

Fan-Tray Assembly

The fan-tray supported on the NCS 2006 shelf is NCS2006-FTA.

The fan-tray assembly is located on the left side of the NCS 2006 shelf. The fan-tray is removable and holds the fan-control circuitry and the fans for the NCS 2006 shelf. It has a single dual-color LED on the faceplate. When the fan-tray assembly is not functioning or when the power line is not connected, the LED is OFF. When the power line is connected and if there is no TNC, TNCE, TSC, or TSCE card installed in the NCS2006 shelf, then the LED is OFF. A red LED indicates an alarm in the fan-tray assembly. A green LED indicates that the fan-tray assembly is functioning, the power line is connected, and the power module is functioning properly. The shelf controller card controls the conditions that result in triggering the LEDs. The LED can be overwritten by the shelf controller card (TNC, TNCE, TSC, or TSCE) in all the three states (OFF/red/green). The fan-tray assembly supports the lamp test procedure. After you install the fan tray, you should only access it if a fan failure occurs.

Fan Speed

The fan speed is controlled by the TNC, TNCE, TSC, or TSCE card temperature sensors. The sensors measure the input air temperature at the fan-tray assembly. Fan speed options are low, medium, and high. If the TNC, TNCE, TSC, or TSCE card fails, the fans automatically shift to high speed. The temperature that the TNC, TNCE, TSC, or TSCE sensors measure appear on the LCD screen.

Fan Failure

If one or more fans fail on the fan-tray assembly, replace the entire assembly. You cannot replace individual fans. The red Fan Fail LED on the front of the fan-tray illuminates when one or more fans fail. The red Fan Fail LED clears after you install a working fan-tray.

NTP-L11 Installing the Fan-Tray Assembly in the NCS 2006 Shelf

Purpose	This procedure installs the NCS2006-FTA fan-tray assembly in the NCS 2006 system.
Tools/Equipment	Small slot-head screwdriver
Prerequisite Procedures	<ul style="list-style-type: none"> • NTP-L2 Mounting the Brackets in ANSI Configuration. • NTP-L5 Opening and Removing the Standard Door of the NCS 2006 Shelf, on page 7. • Connect the chassis to the office ground. For detailed instructions on how to ground the chassis, see the Electrostatic Discharge and Grounding Guide for Cisco NCS 2000 Series.
Required/As Needed	Required
Onsite/Remote	Onsite
Security Level	None



Caution Do not operate an NCS 2006 without an air filter.



Caution Do not force a fan-tray assembly into place. Doing so can damage either the connectors on the fan tray or the connectors on the backpanel of the shelf, or both.



Note Error messages appear on the TNC, TNCE, TSC, or TSCE card, the fan-tray LED, and in the Cisco Transport Controller (CTC) when the fan-tray assembly is removed from the shelf or when one fan is not working.



Note To install the fan-tray assembly, it is not necessary to move any of the fiber-routing facilities.

Procedure

Step 1 Insert the fan-tray assembly inside the left slot (fan tray slot) of the NCS 2006 chassis (see the figure below).

Figure 36: Installing the Fan-Tray Assembly

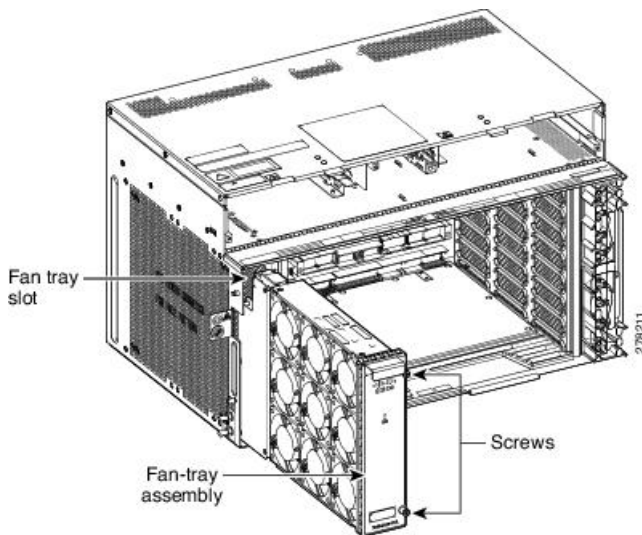

Step 2 Push the fan-tray assembly such that the backplane connector is engaged completely.

Step 3 Tighten the screws to a torque value of 4 in-lb (0.45 N-m) to lock the fan-tray assembly into the chassis (see the figure below).

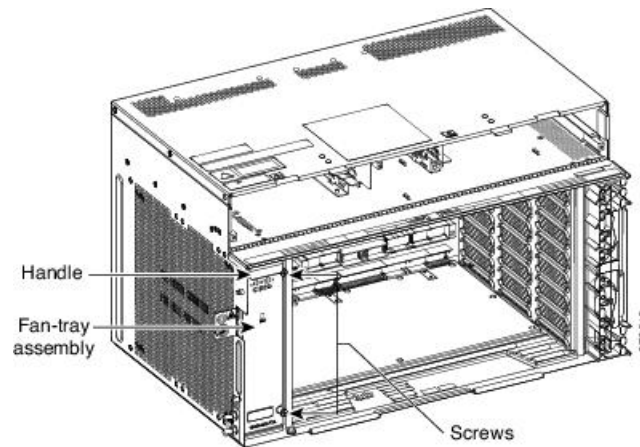
Figure 37: Fan Tray Assembly Installed

- Step 4** To verify that the tray has plugged into the assembly, check the fan tray and listen to determine if the fans are running.

Stop. You have completed this procedure.

Air Filter

The NCS 2006 contains a preinstalled disposable air filter (15454-M6-FTF=) on the right side of the shelf.

The disposable filter is made up of a gray, open-cell, polyurethane foam that is specially coated to provide fire and fungi resistance. Spare filters should be kept in stock. Inspection of the air filter must be performed as specified in your local site practices.

First inspection of the air filter should be performed six months after the system installation. Air filters must be inspected every quarter after the initial six month inspection. If they are dirty or clogged with dust, they must be replaced with a new air filter.



Caution Do not operate an NCS 2006 without the mandatory air filter.
