



Connecting and Routing the Cables

This chapter explains how to connect and route the cables for NCS 2006.

The sections are:

- [Cable Routing and Management, on page 1](#)
- [NTP-L13 Installing the Cable and Fiber Modules, on page 2](#)
- [NTP-L14 Attaching Wires to Alarm, Timing, LAN, and Craft Pin Connections, on page 8](#)

Cable Routing and Management

The NCS 2006 shelf has interchangeable fiber and cable modules. Because the NCS 2006 shelf is designed to be compliant with and ETSI 600x300 standards, all the wiring and cable connections are available on the front side.

Default Module

The NCS 2006 chassis is shipped with the fiber module installed. If you need to use CAT5 cables instead of optical fibers, you can replace the fiber module with the cable module.

Fiber Module

The minimum fiber bend radius is 1.5 inches. The fiber guide can be replaced with a cable guide to route the CAT-5 Ethernet cables. The maximum number of 2 mm diameter patch cords that can be managed is 144, or alternatively, 72 CAT5 cables. To manage extra length fiber and fan out, a dedicated fiber storage unit and patch panel unit can be installed inside the rack. The maximum capacity of the fiber channel for one side of the shelf depends on the fiber size and number of Ethernet cables running through that fiber channel. The details of the fibers are:

- 24 fiber x 6 line cards = 144 fibers (72 fibers for each exit point) or 12 CAT5 cables x 6 line cards = 72 RJ45 cables (36 CAT5 cables for each exit point)
- 4 fibers and 1 RJ45 cable x 2 TNC or TNCE = 8 fibers (4 fibers for each exit point) + 2 CAT5 cables (1 CAT5 cable for each exit point)

The fiber diameter is a maximum of 2 mm and the CAT5 cable diameter is a maximum of 5 to 6 mm. You need to determine your fiber size according to the number of cards and ports installed on each side of the shelf. For example, if your port combination requires 36 fibers, 3-mm (0.11-inch) fiber is adequate. If your port combination requires 68 fibers, you must use 2-mm (0.7-inch) or smaller fibers.



Note The minimum distance between the fiber LC connector and the bulk attenuator must be at least 50 cm. This is the minimum distance required to place the bulk attenuator outside the shelf from any port of a card.

Cable and Fiber Routing

Cable and fiber routing accommodates all the high-density cards for line card connections in NCS 2006. The exit of the fibers and cables is split into two channels. The line card from slot 1 to 4 exits from the lower right side, and the line card from 5 to 8 exit from the upper right side. (See the figure below .)

Figure 1: Cable and fiber routing

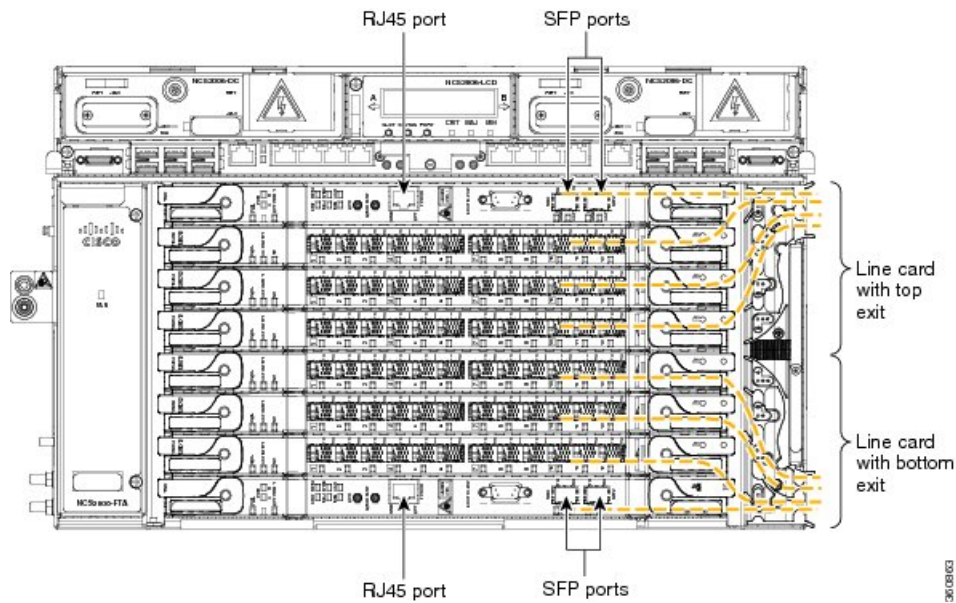

NTP-L13 Installing the Cable and Fiber Modules

Purpose	This procedure installs the cable and fiber modules in the NCS 2006 system.
Tools/Equipment	#1 Phillips cross-head PH screwdriver
Prerequisite Procedures	None
Required/As Needed	As needed
Onsite/Remote	Onsite
Security Level	None

Procedure

- Step 1** Complete [DLP-L23 Removing the Fiber Module, on page 3](#).
- Step 2** Complete [DLP-L24 Installing the Cable Module, on page 4](#).
- Step 3** Complete [DLP-L25 Routing and Locking Cables, on page 5](#).

Stop. You have completed this procedure.

DLP-L23 Removing the Fiber Module

Purpose	This procedure removes the default fiber module in the NCS 2006 system.
Tools/Equipment	#1 Phillips cross-head PH screwdriver
Prerequisite Procedures	None
Required/As Needed	As needed
Onsite/Remote	Onsite
Security Level	None

Procedure

- Step 1** Loosen the screws on the fiber module present on the right side of the NCS 2006 assembly. (See the figure below)
- Step 2** Loosen the screw present on the air filter locking feature of the NCS 2006 shelf.
- Step 3** Remove the air filter locking feature by holding the air filter and gently pulling the air filter locking feature away from the shelf.
- Step 4** Extract the fiber module by gently removing it from the NCS 2006 shelf.

Figure 2: Removing the Fiber module

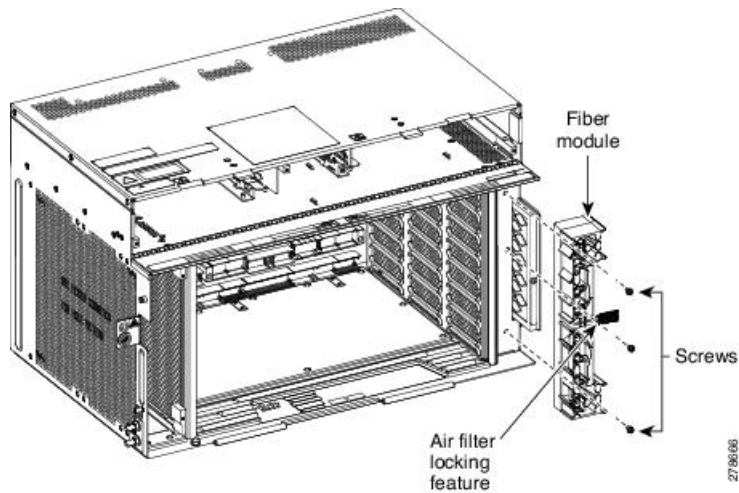

Step 5 Return to your originating procedure (NTP).

DLP-L24 Installing the Cable Module

Purpose	This procedure installs the cable module in the NCS 2006 system.
Tools/Equipment	Phillips cross-head PH screwdriver #1
Prerequisite Procedures	DLP-L23 Removing the Fiber Module, on page 3
Required/As Needed	As needed
Onsite/Remote	Onsite
Security Level	None

Procedure

- Step 1** Insert the air filter locking feature on the cable module. (See the figure below)
- Step 2** Attach the slot label identity on the cable module, with screws.
- Step 3** Mount the cable module on the chassis, and tighten the screws to a torque value of 4 in-lb (0.45 N-m) to attach the cable module to the NCS 2006 shelf.

Figure 3: Installing the Cable Module

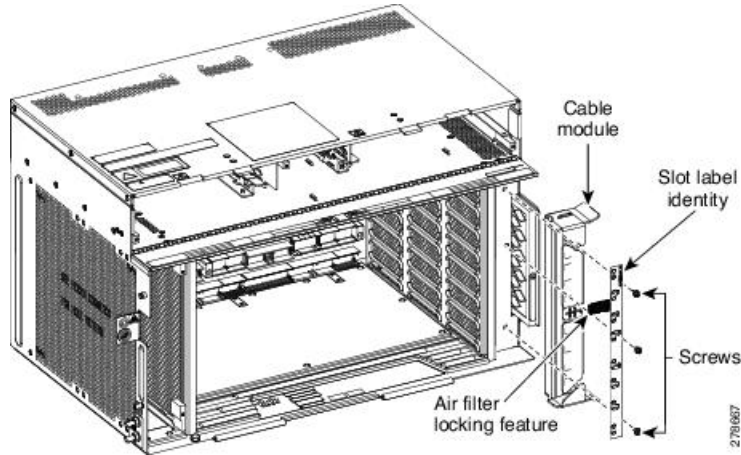

Step 4 Return to your originating procedure (NTP).

DLP-L25 Routing and Locking Cables

Purpose	This task routes and locks the cables on the NCS 2006 system.
Tools/Equipment	None
Prerequisite Procedures	None
Required/As Needed	As needed
Onsite/Remote	Onsite
Security Level	None

Procedure

Step 1 Route the ECU cables on both the ECU ejectors.

The following figure shows an example of ECU cable routing. This allows you to close the front door. Ensure an extra length of ECU cable is available to allow cable management during extraction of the power module.

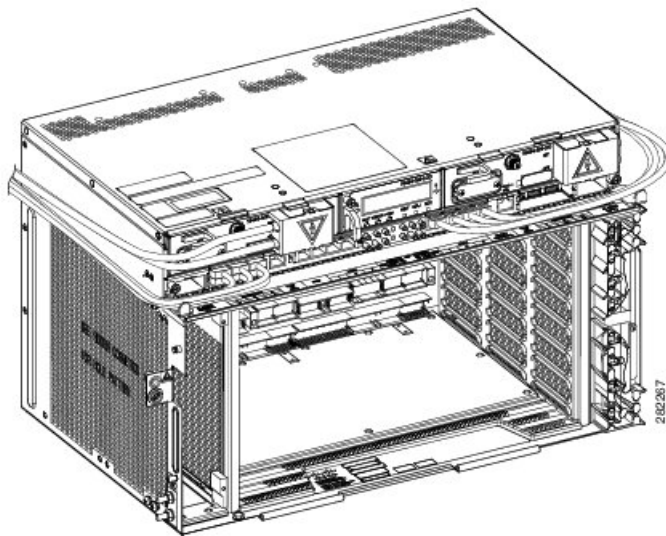
Figure 4: ECU module Cable Routing

It is also possible to manage the extraction of the power module without adding the extra length of ECU cable by reducing the number of cables in the right exit area (see Diagram 1 of the figure below). An extra length of ECU cable is required in the left exit area to manage the USB connections (see Diagram 2 of the figure below).

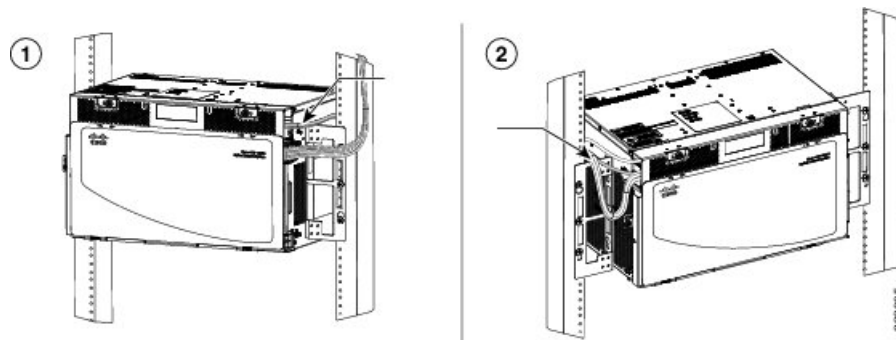
Figure 5: Cable Management

Step 2 Fix the cables using the tie-wrap provided in the accessories kit.

Step 3 To route the optical patch cords or copper cables, do the following as necessary:

- a) Route the optical patch cords from the line cards through the fiber or cable module as shown in the figure below .

Figure 6: Cable Routing

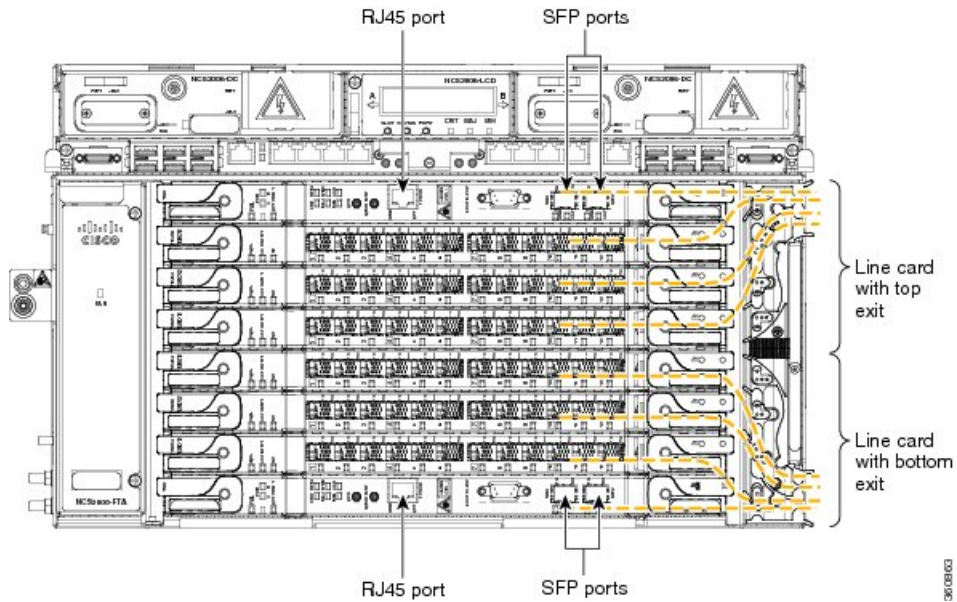

- b) Remove the front door and connect the copper cables to the SFP or RJ-45 ports of the cards. Do not route the copper cables from the SFPs or RJ-45 ports through the fiber or cable module.

Step 4

To extract the power module, do the following:

- Open the door of the chassis. See Diagram 2 of the figure below .
- Move the ECU cables away from the chassis. Ensure that the alarm cable with the plastic bend radius controller is not moved. See Diagram 3 of the figure below .
- Remove the power module. See Diagram 4 of the figure below .

Figure 7: Sequence to Remove the Power Module

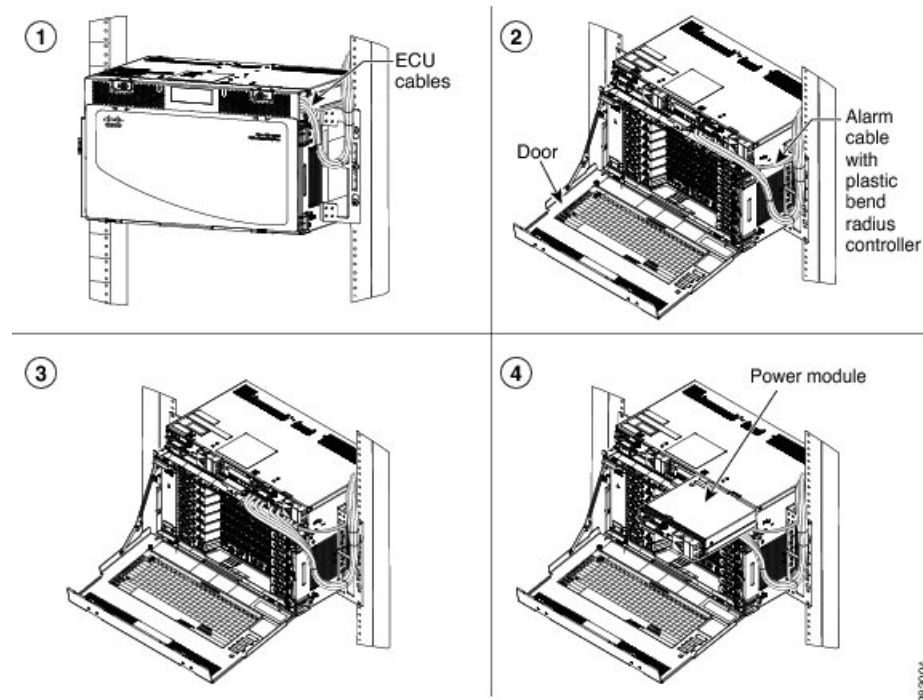

Step 5 Return to your originating procedure (NTP).

NTP-L14 Attaching Wires to Alarm, Timing, LAN, and Craft Pin Connections

Purpose	Use this procedure to attach alarm, timing, LAN, and craft wires in the NCS 2006 shelf.
Tools/Equipment	Twisted #22 or #24 AWG (0.51 mm ² or 0.64 mm ²) shielded wires for LAN or craft 75-ohm coaxial cable with DIN-1.0/2.3 miniature coaxial connector, Alarm 26 pins SCSI cable.
Prerequisite Procedures	NTP-L8 Install the NCS 2006 ECU and ECU-S Modules
Required/As Needed	As needed
Onsite/Remote	Onsite
Security Level	None



Caution Always use the supplied ESD wristband when working with a powered NCS 2006. For detailed instructions on how to wear the ESD wristband, see the [Electrostatic Discharge and Grounding Guide for Cisco NCS 2000 Series](#).

Procedure

- Step 1** Complete [DLP-L26 Installing Alarm Wires in NCS 2006](#), on page 9 if you are provisioning external alarms.
- Step 2** Complete [DLP-L27 Installing Timing Wires on NCS 2006 - ANSI](#), on page 13 if you are provisioning external timing in .
- Step 3** Complete [DLP-L28 Installing Timing Wires in NCS 2006 - ETSI](#), on page 15 if you are provisioning external timing in ETSI.
- Step 4** Complete [DLP-L29 Installing LAN Wires in NCS 2006](#), on page 17 to create an external LAN connection.

Table 1: PIDs for SCSI Cables

Cable	PID	Length	Wire Dimension
SCSI alarm cable	15454-M-ALMCBL=	20 Meter	28 AWG
SCSI alarm patch cable	15454-M-AEXPCBL=	1 Meter	28 AWG
SCSI alarm wire-wrap cable	15454-M-ALMCBL2=	20 Meter	24 AWG

Note

Some wire-wrap tools require a minimum of 24 AWG wires to prevent breakage. Ensure that the SCSI alarm wire-wrap cable is used for 24 AWG wires. When the SCSI alarm wire-wrap cable is used, the number of alarms is reduced as fewer strands of wire are supported compared to the SCSI alarm and SCSI alarm patch cables. Table 5-5 lists alarm connector pin details for SCSI alarm wire-wrap cable.

Stop. You have completed this procedure.

DLP-L26 Installing Alarm Wires in NCS 2006

Purpose	This task installs alarm cables on the ECU module of the NCS 2006 to provision external (environmental) alarms and controls.
Tools/Equipment	Alarm SCSI 26-pin cable Wire-wrap tool for BITS Screw for the alarm cable
Prerequisite Procedures	NTP-L8 Install the NCS 2006 ECU and ECU-S Modules
Required/As Needed	As needed

Onsite/Remote	Onsite
Security Level	None

Procedure

Step 1 Connect one end of the SCSI cable to the input alarms or input/output alarms, and the other end to the alarm source (See Diagram 1 of the figures below).

Note

These alarms are generic signals that the operator assigns to a definite wire (color) and name through the Craft Terminal.

Step 2 Tighten the screws of the SCSI connector to a torque value of 4 in-lb (0.45 N-m) using #2 Philips Dynamometric screwdriver. See Diagram 2 of the figures below.

Step 3 Bend the cable at an angle of 90° to exit from the left side or the right side (see the figures below).

Step 4 Snap the cable bend controller on the cable. See Diagram 4 of the figures below.

Step 5 Return to your originating procedure (NTP).

Figure 8: Installing the ECU Alarm Cable—Left Exit Option

Left exit option

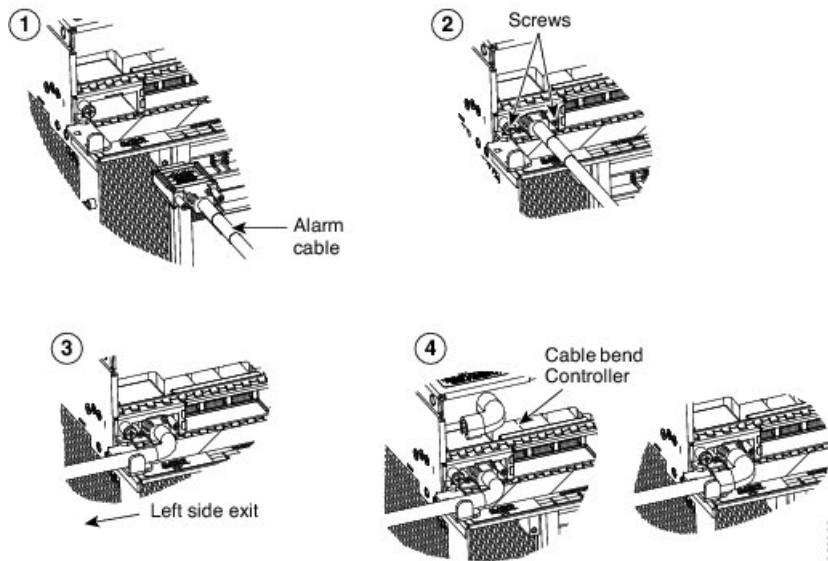

Figure 9: Installing the ECU Alarm Cable—Right Exit Option

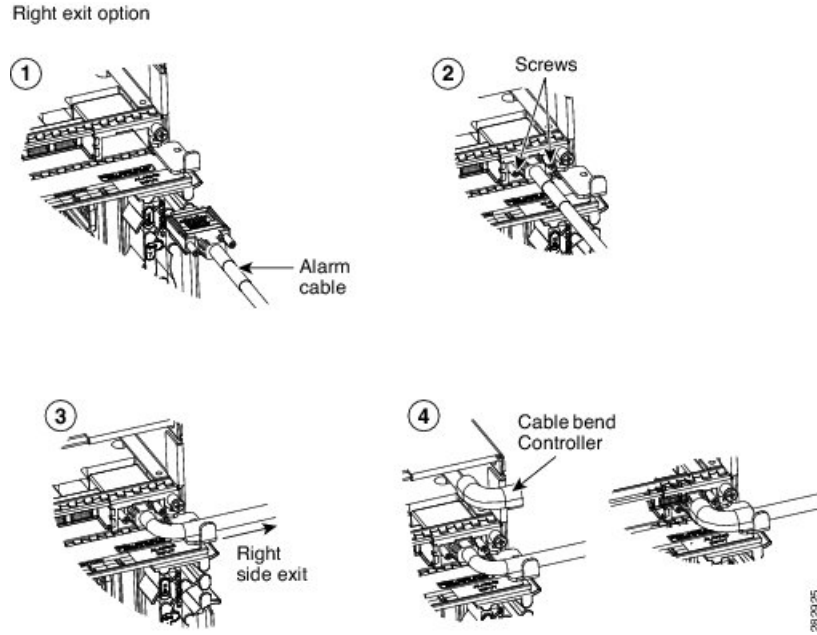

Table 2: SCSI Alarm Cable (15454-M-ALMCBL) and SCSI Alarm Patch Cable (15454-M-AEXPCBL) Connector Details

Pin Number	Color Code	Input Alarms - Right Alarm Connector	Input-Output Alarms - Left Connector
1	Black/Brown	Input Pair #1 +	Minor Audible Alarm +
2	Black/Red	Input Pair #2 +	Major Audible Alarm +
3	Black/Orange	Input Pair #3 +	Critical Audible Alarm +
4	Black/Yellow	Input Pair #4 +	Remote Audible Alarm +
5	Black/Green	Input Pair #5 +	Minor Visual Alarm +
6	Black/Blue	Input Pair #6 +	Major Visual Alarm +
7	White/Blue	Input Pair #7 +	Critical Visual Alarm +
8	White/Orange	Input Pair #8 +	Remote Visual Alarm +
9	White/Green	Input Pair #9 +	—
10	White/Brown	Input Pair #10 +	Alarm Cutoff (ACO) +
11	—	—	—
12	White/Gray	Output Pair #3 + or Input Pair #13 +	Output Pair #1 + or Input Pair #11 +
13	Black/Gray	Output Pair #4 + or Input Pair #14 +	Output Pair #2 + or Input Pair #12 +
14	Brown/Black	Input Pair #1 -	Minor Audible Alarm -

Pin Number	Color Code	Input Alarms - Right Alarm Connector	Input-Output Alarms - Left Connector
15	Red/Black	Input Pair #2 -	Major Audible Alarm -
16	Orange/Black	Input Pair #3 -	Critical Audible Alarm -
17	Yellow/Black	Input Pair #4 -	Remote Audible Alarm -
18	Green/Black	Input Pair #5 -	Minor Visual Alarm -
19	Blue/Black	Input Pair #6 -	Major Visual Alarm -
20	Blue/White	Input Pair #7 -	Critical Visual Alarm -
21	Orange/White	Input Pair #8 -	Remote Visual Alarm -
22	Green/White	Input Pair #9 -	—
23	Brown/White	Input Pair #10 -	Alarm Cutoff (ACO) -
24	—	—	—
25	Gray/White	Output Pair #3 - or Input Pair #13 -	Output Pair #1 - or Input Pair #11 -
26	Gray/Black	Output Pair #4 - or Input Pair #14 -	Output Pair #2 - or Input Pair #12 -

Table 3: SCSI Alarm Wire-Wrap Cable (15454-M-ALMCBL2) Connector Details

Pin Number	Color Code	Input Alarms - Right Alarm Connector	Input-Output Alarms - Left Connector
1	Black/Brown	Input Pair #1 +	Minor Audible Alarm +
2	Black/Red	Input Pair #2 +	Major Audible Alarm +
3	—	—	—
4	Black/Yellow	Input Pair #4 +	Remote Audible Alarm +
5	Black/Green	Input Pair #5 +	Minor Visual Alarm +
6	Black/Blue	Input Pair #6 +	Major Visual Alarm +
7	White/Blue	—	—
8	White/Orange	Input Pair #8 +	Remote Visual Alarm +
9	White/Green	Input Pair #9 +	—
10	White/Brown	Input Pair #10 +	Alarm Cutoff (ACO) +
11	—	—	—
12	—	—	—
13	—	—	—

Pin Number	Color Code	Input Alarms - Right Alarm Connector	Input-Output Alarms - Left Connector
14	Brown/Black	Input Pair #1 -	Minor Audible Alarm -
15	Red/Black	Input Pair #2 -	Major Audible Alarm -
16	—	—	—
17	Yellow/Black	Input Pair #4 -	Remote Audible Alarm -
18	Green/Black	Input Pair #5 -	Minor Visual Alarm -
19	Blue/Black	Input Pair #6 -	Major Visual Alarm -
20	—	—	—
21	Orange/White	Input Pair #8 -	Remote Visual Alarm -
22	Green/White	Input Pair #9 -	—
23	Brown/White	Input Pair #10 -	Alarm Cutoff (ACO) -
24	—	—	—
25	—	—	—
26	—	—	—

DLP-L27 Installing Timing Wires on NCS 2006 - ANSI

Purpose	This task installs the timing cables on the NCS 2006 ECU module for ANSI.
Tools/Equipment	Wire-wrap tool and 100-ohm wire-wrap cable.
Prerequisite Procedures	NTP-L8 Install the NCS 2006 ECU and ECU-S Modules
Required/As Needed	As needed
Onsite/Remote	Onsite
Security Level	None

Procedure

- Step 1** Locate the timing connector on the ECU module (BITS-1 or BITS-2 In/Out). The following figure shows ECU module wire-wrap pins.

Figure 10: ECU module Wire-wrap Pins

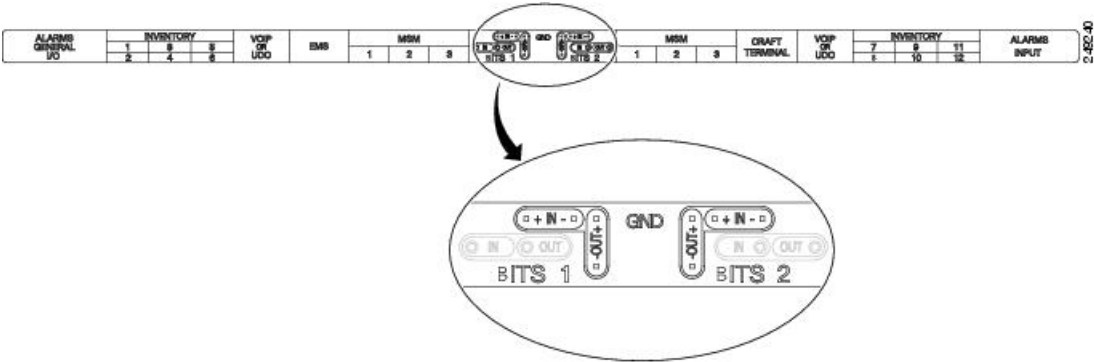

The following table lists the ECU module pin assignments for ANSI.

Table 4: ECU module Pin Assignments - ANSI

Pin	Function
IN 1	Input from external drive
OUT 1	Output to external drive
IN 2	Input from external drive
OUT 2	Output to external drive

Step 2 Connect one end of the wire-wrap clock cable to the corresponding wire-wrap connector on the ECU module, and the other end to the external source of the timing. Change the timing input to high-impedance (lesser or greater than 3 ohms) using a jumper on the ECU module. Remove the P1 jumper of the BITS-1 to change the top timing input, and the P2 Jumper of the BITS-2 to change the bottom timing input.

Note Route the wire-wrap connections as shown in the figure below to prevent interference with the MSM ports.

Figure 11: ECU module Wire-wrap Cabling— ANSI

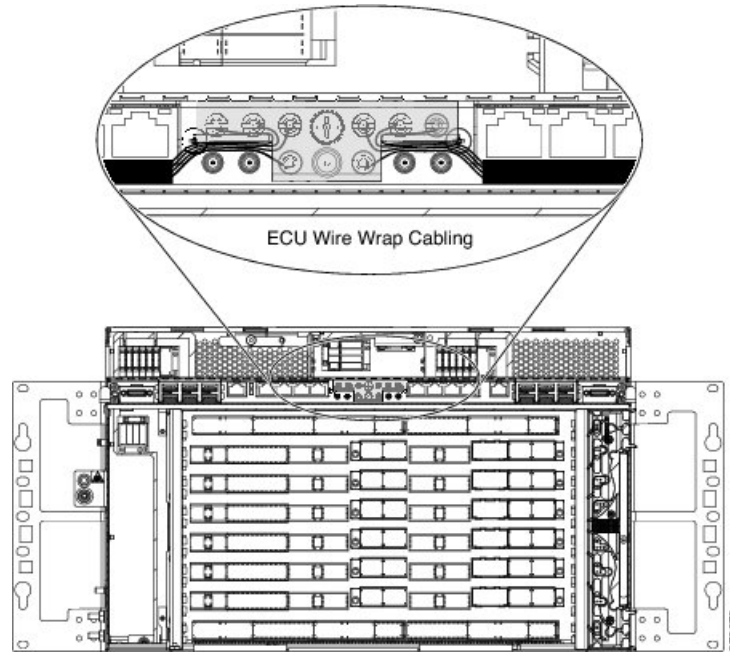

- Step 3** Repeat for each cable. Refer to ITU-T G.813 for rules about provisioning timing references.
- Step 4** Return to your originating procedure (NTP).

DLP-L28 Installing Timing Wires in NCS 2006 - ETSI

Purpose	This task installs the timing cables on the NCS 2006 ECU module for ETSI.
Tools/Equipment	75-ohm coaxial cable with a DIN-1.0/2.3 miniature coaxial connector. The PID for the BITS IN/OUT cable is 15454-M-TMGCBL=
Prerequisite Procedures	NTP-L8 Install the NCS 2006 ECU and ECU-S Modules
Required/As Needed	As needed
Onsite/Remote	Onsite
Security Level	None

Procedure

- Step 1** Connect the clock cable to the corresponding ECU module connector using a coaxial cable with DIN-1.0/2.3 miniature coaxial connectors. The following figure shows the ECU module ETSI BITS connectors.

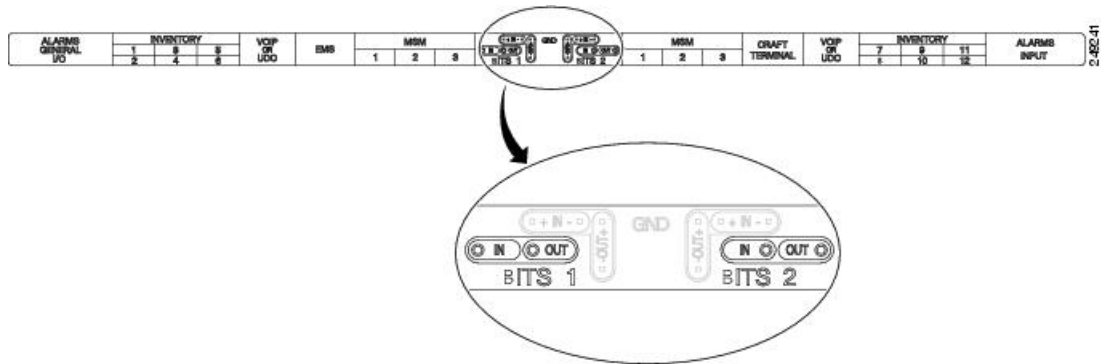

The following figure shows cable routing of ECU module ETSI BITS connectors.

Figure 12: ECU module ETSI BITS Connectors Cabling

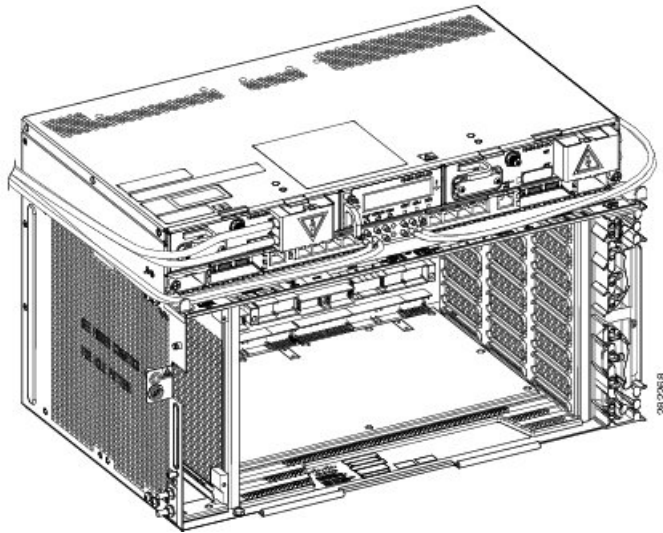

Step 2

Gently push the cable connector into the ECU module connector until you hear a click. Perform the following steps to mate the connectors:

- Slide the coupling sleeve of the coaxial cable backward. See diagram1 of the figure below.
- Connect the cable to the ECU module connector. See diagram2 of the figure below.
- Slide the coupling sleeve forward to lock the cable connector to the ECU module connector. See diagram3 of the figure below.

Note

To unlock the cable connector from the ECU module connector, hold the connector and slide the coupling sleeve backward. See diagram 4 of the figure below.

Figure 13: Sequence to Attach the Connectors

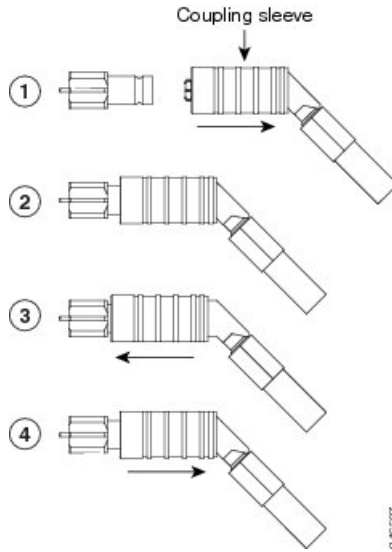

Note

The ECU module provides 1.0/2.3 miniature coaxial connectors used for timing input and output. The top connectors are for “A” (BITS-1) timing, and the bottom connectors are for “B” (BITS-2) timing. In each case, the left connector is the input and the right connector is the output. The input connectors for timing provide a 75-ohm termination.

Step 3 Connect the other end of the cable to the external source of the timing signal according to the table below . Repeat for each cable.

Table 5: ECU module Pin Assignments - ETSI

Pin	Function
IN 1	Input from external drive
OUT 1	Output to external drive
IN 2	Input from external drive
OUT 2	Output to external drive

Step 4 Change the timing input to high-impedance (lesser or greater than 3 ohms) using a jumper on the ECU module. Remove the P1 jumper of the BITS-1 to change the top timing input, and the P2 Jumper of the BITS-2 to change the bottom timing input. Refer to ITU-T G.813 for rules about provisioning timing references.

Step 5 Return to your originating procedure (NTP).

DLP-L29 Installing LAN Wires in NCS 2006

Purpose	This task installs LAN wires on the ECU module of the NCS 2006.
----------------	---

Tools/Equipment	Standard CAT-5 Ethernet cable (straight-through for data terminating equipment [DTE] or cross-over for data circuit-terminating equipment [DCE]) or RJ-45 connector Crimping tool for RJ-45 connector 0.51 mm ² or 0.64 mm ² (#22 or #24 AWG) wire, preferably CAT-5
Prerequisite Procedures	NTP-L8 Install the NCS 2006 ECU and ECU-S Modules
Required/As Needed	As needed
Onsite/Remote	Onsite
Security Level	None

We recommend the use of RJ-45 port (craft terminal port or the EMS port) on the ECU module to establish LAN connectivity. The advantages of using the RJ-45 ports on the ECU module include:

- CAT-5 Ethernet cable connections can be managed better by routing the cable through the ECU module cable exit area.
- If the TNC, TNCE, TSC, or TSCE card fails, the LAN connection is not lost during the TNC, TNCE, TSC, or TSCE card switch over.

If the ECU module is absent, you can connect a CAT-5 Ethernet cable to the LAN port on the TNC/TNCE/TSC/TSCE card to create an external LAN connection.



Note You can use the same procedure to connect Multishelf Management ports of several chassis in MSM configurations.



Note To avoid duplex mismatch between EMS or craft terminal port and external LAN switch port, auto negotiation must be enabled on the external LAN switch port.

Procedure

-
- Step 1** Using 0.51 mm² or 0.64 mm² (#22 or #24 AWG) wire or a standard CAT-5 Ethernet cable, connect the wires to the RJ-45 connector.
- Step 2** Return to your originating procedure (NTP).
-