



Plot Legend for Design Layouts

This legend is for Design layouts used in the WAE Design GUI.







Note

All traffic is displayed in Mbps. In the network plot, the traffic utilization colors represent outbound traffic. L3 means Layer 3, and L1 means Layer 1.

Legend	Descriptions
Interfaces and Circuits	Interfaces and Circuits
	Circuit Colors
	Circuit Active, Failed, and Operational States
Nodes	L3 Nodes (L3 means Layer 3)
Sites	Sites
Demands and Routings	Demands
	Demand Segment Lists
External Endpoint Members	External Endpoint Members
LSPs	LSP Paths
	LSP Named Paths
	LSP Actual Paths
	Segment-Routed LSP Paths
L1 Objects (L1 means Layer 1)	L1 Links
	L1 Circuit Paths
	L1 Circuit Path Hops
	L1 Nodes, L1 Ports, and L1 Waypoints

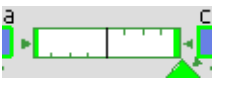
Interfaces and Circuits

Table 26-1 Interface and Circuit Visualization

Graphic	Description
	Circuits are rectangles divided in half by a vertical black line. Each half shows an interface. Tick marks show 25%, 50%, 75% utilization levels.
	Width of circuit shows capacity. Width increases a fixed amount for every 4x increase in capacity.
	Full-length interface style, which is the default.
	Shortened interface style, showing the same information as a full-length view, just in shorter representations that are repeated at each end of the circuit. In this example, all chi interfaces are shortened at both ends of the circuit.
	Collapsed interface view, showing the presence of interfaces as up/down arrows inside the site. The color of the arrows show the highest utilization of any of the collapsed interfaces (in this example, blue for sea and yellow for chi). In this example, all chi interfaces are collapsed at both ends of the circuit.

Circuit Colors

Table 26-2 Interface and Circuit Colors

Graphic	Description
The traffic utilization colors are customizable. For information, see the <i>WAE Network Visualization Guide</i> .	
	Blue indicates a selected interface or circuit.

Table 26-2 Interface and Circuit Colors (continued)





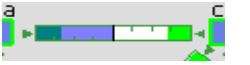

Graphic	Description
	<p>Outbound traffic utilization is depicted by colors. Default colors are light blue, light green, yellow, orange, red, and purple, and left to right, each of these colors represent increased utilization.</p> <ul style="list-style-type: none"> • Measured Traffic and Simulated Traffic views—The color shows the percent of traffic utilized for the available interface capacity. • Worst-Case Traffic view—The color represents the worst-case utilization on each interface. This is the highest utilization that a particular interface experiences over all the failure scenarios considered when running a simulation analysis. See the Simulation Analysis chapter. • Failure Impact view—The color represents the failure impact of a circuit. This is defined as the highest utilization experienced by any interface if that circuit were to fail. See the Simulation Analysis chapter. • LSP Reservation view—The color represents the total setup bandwidth that is reserved by LSPs through the interface.
	<p>If parallel circuits are grouped for visual display, each side of the circuit shows its constituent interfaces. Here, there are two circuits (two interfaces on each side) grouped by site. If the circuits are between sites, the utilization includes the utilization of nested interfaces, if applicable.</p> <ul style="list-style-type: none"> • The color fill on each side shows the average utilization of the grouped interfaces, which is weighted against the sum of the grouped capacities. For example, the average utilization for the interfaces from chi to mia is between 30 and 50% and is shown as a green color. • Each interface within a grouped circuit has a thin colored border showing the utilization of that interface. For example, one interface going from mia to chi is bordered by yellow and another by blue, each showing the traffic utilization for the bordered interface.
	<p>White indicates 0% utilization.</p>
	<p>Interfaces are light gray for the following reasons.</p> <ul style="list-style-type: none"> • Measured Traffic view <ul style="list-style-type: none"> – The interface has no traffic measurement. – This amount of interface capacity is not available due to a QoS bound. • Simulated Traffic view—This amount of interface capacity is not available due to a QoS bound. • Worst-Case Traffic view—No simulation analysis was performed. • Failure Impact view <ul style="list-style-type: none"> – No simulation analysis was performed. – Failing the circuit would not increase the traffic utilization on any other circuit. • Circuit is operationally down.
	<p>QoS policy violations are indicated by red and white bars. This is displayed when utilization exceeds the QoS bound, which is set through policy or interface queue properties. See the Quality of Service Simulation chapter.</p>
	<p>Shortest IGP path between two selected nodes or sites. See the IGP Simulation chapter.</p>

Table 26-2 Interface and Circuit Colors (continued)

Graphic	Description
	Shortest latency path between two selected nodes or sites. See the IGP Simulation chapter.
	Shortest TE path between two selected nodes or sites. See the IGP Simulation chapter.

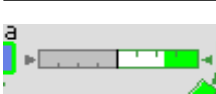
Circuit Active, Failed, and Operational States

Table 26-3 Circuit Active, Failed, and Operational States







Graphic	Description
	Failed circuit.
	<p>Circuit is not operational for one of the following reasons.</p> <ul style="list-style-type: none"> • A node connected to the circuit failed. • A site failed that contains a node connected to the circuit. • The circuit is a LAG¹ (port channel) that does not meet its operational requirements (minimum number of available ports or minimum capacity, whichever is surpassed first) due to failure of some of its ports or port circuits. • Mapped L1 circuit cannot be routed because it traverses a failed L1 port, L1 node, or L1 link. • An SRLG failed that contains the circuit or contains one of the above objects that are required for circuit operation.
	The circuit is a LAG, and one or more ports or port circuits in the LAG failed. The red strikeout line is the percent of unavailable capacity due to the failure.
	Circuit is inactive.

Table 26-3 Circuit Active, Failed, and Operational States (continued)

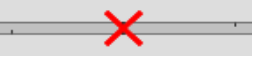
Graphic	Description
	<p>Circuit is not operational for one of the following reasons.</p> <ul style="list-style-type: none"> • A node connected to the circuit is inactive. • An inactive site contains a node connected to the circuit. • The circuit is a LAG that does not meet its operational requirements (minimum number of available ports or minimum capacity, whichever is surpassed first) due to some of its ports or port circuits being inactive. • Mapped L1 circuit cannot be routed because it traverses an inactive L1 port, L1 node, or L1 link. • An SRLG is inactive, and the SRLG contains the circuit or contains one of the above objects that is required for circuit operation.
	<p>The circuit is a LAG and one or more ports or port circuits in the LAG is inactive. The gray strikeout line is the percent of unavailable capacity due to the inactive ports or port circuits.</p>

1. A link aggregation group (LAG) is a group of physical ports that are bundled into a single logical interface. It is also known as *bundling* or *trunking*.

L3 Nodes

Table 26-4 Layer 3 Node Visualization











Graphic	Description
	<p>A node is shown as a blue rectangle with a border. Solid blue indicates the node is selected.</p>
	<p>The green border surrounds the node as follows.</p> <ul style="list-style-type: none"> • Simulated Traffic View—The node is the source or destination of simulated traffic that is greater than 0. • Measured Traffic View—The node is the source or destination of measured traffic that is greater than 0. • LSP Reservation View—The node is the source or destination of LSPs with nonzero bandwidth reservations.
	<p>A white border surrounds the node as follows.</p> <ul style="list-style-type: none"> • Simulated Traffic View—The node is not the source or destination of simulated traffic. • Measured Traffic View—The node has ingress and egress traffic of 0 (zero). • LSP Reservation View—The node is the source or destination of LSPs with 0 (zero) bandwidth reservations.
	<p>A gray border surrounds the node as follows.</p> <ul style="list-style-type: none"> • Measured Traffic View—The node has no ingress or egress traffic. • Worst-Case Traffic View—Nodes always have gray borders. • Failure Impact View—The node is not included in the failures considered, or failing the node would not increase the traffic utilization on any circuit.
	<p>In the Failure Impact view, the node border color represents the failure impact of a node. This is defined as the highest utilization experienced by any circuit if that node were to fail. See the Simulation Analysis chapter.</p>

Table 26-4 Layer 3 Node Visualization (continued)

Graphic	Description
	Up/down triangles show that some interfaces from the node have been collapsed.
	Failed node.
	Node is not operational because it is contained in a failed site or in a failed SRLG.
	Node is not active.
	Node is not operational because it is contained in a site or an SRLG that is not active.
	One or more selected VPN nodes exist on the node.

Sites

Site utilization colors and symbols are based on intrasite objects, that is, objects that are contained completely within it. Note that intrasite objects include child sites and the objects contained within them.

Table 26-5 Site Visualization



Graphic	Description
	A site is shown as a blue square with a border. Solid blue indicates the site is selected.
	<ul style="list-style-type: none"> • Layer 3 view <ul style="list-style-type: none"> – Measured Traffic and Simulated Traffic views—The border color is the maximum traffic utilization color of all intrasite interfaces within the site. – Worst-Case Traffic view—The border color is the highest utilization that the interfaces within it experience over all the failure sets selected for Simulation Analysis. – Failure Impact view—The border color is the maximum utilization level that would be caused elsewhere in the network should an L3 node or L3 circuit contained within it fail. • Layer 1 Failure Impact view—The border color is the maximum utilization level that would be caused elsewhere in the network should an L1 node or L1 link contained within it fail. • Multi-Layer Failure Impact View—The border color is the maximum utilization level that would be caused elsewhere in the network should any L1 or L3 intrasite object fail.

Table 26-5 Site Visualization











Graphic	Description
	<ul style="list-style-type: none"> Layer 3 view—A white border surrounds the site if all intrasite interfaces have zero utilization. Layer 1 view—The sites always have white borders except in Failure Impact view.
	<p>A gray border surrounds the site in the following cases.</p> <ul style="list-style-type: none"> Layer 3 view <ul style="list-style-type: none"> Measured Traffic view—There is no measured traffic on intrasite interfaces. Worst-Case and Failure Impact views—No simulation analysis was performed. Failure Impact view—Failing an intrasite L3 node or L3 circuit would not increase the traffic utilization on any L3 circuit. Layer 1 Failure Impact view—Failing an intrasite L1 node or L1 link would not increase the traffic utilization on any L3 circuit. Multi-layer Failure Impact view—Failing an L1 or L3 intrasite object would not increase the traffic utilization on any L3 circuit.
	The small box indicates that one or more intrasite objects is selected. If in a multi-layer view, this includes both L1 and L3 intrasite objects.
	<ul style="list-style-type: none"> Layer 3 view—Up/down triangles show that one or more egress interfaces from within the site have been collapsed. Layer 1 view—Not applicable
	The site failed.
	One or more intrasite objects failed. If in a multi-layer view, this includes both L1 and L3 intrasite objects.
	<ul style="list-style-type: none"> Layer 3 view <ul style="list-style-type: none"> One or more L3 nodes or L3 circuits contained within the site are not operational because they are contained in a failed SRLG. One or more L3 nodes or L3 circuits within the site are associated with a failed L1 port, L1 node, or L1 link. Layer 1 view—One or more L1 nodes or L1 links contained within the site are not operational because they are contained in a failed SRLG. Multi-layer view—One or more intrasite objects are not operational because they are contained in a failed SRLG.
	The site is inactive.
	One or more intrasite objects are inactive. If in a multi-layer view, this includes both L1 and L3 intrasite objects.

Table 26-5 Site Visualization

Graphic	Description
	<ul style="list-style-type: none"> Layer 3 view <ul style="list-style-type: none"> One or more L3 nodes or L3 circuits contained within the site are not operational because they are contained in an SRLG that is not active. One or more L3 nodes or L3 circuits within the site are associated with an inactive L1 port, L1 node, or L1 link. Layer 1 view—One or more L1 nodes, or L1 links contained within the site are not operational because they are contained in an SRLG that is not active. Multi-layer view—One or more intrasite objects are not operational because they are contained in an SRLG that is not active.
	<ul style="list-style-type: none"> Layer 3 view—One or more selected VPN L3 nodes exist on nodes within the site. Layer 1 view—Not applicable

Demands

Table 26-6 Demand Visualization











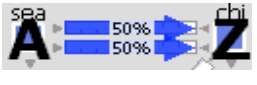

Graphic	Description
For more information, see the Traffic Demand Modeling chapter.	
	"A" and "Z" mark source and destination site/node of a demand. Blue arrows show demands routed through an interface on a circuit.
	Percentages show the proportion of a split demand (for example from ECMP) through an interface.
	Reroute of a demand under a failure.
	Demand is routed through an LSP.
	Demand is rerouted through an FRR LSP.
	Shortest IGP path of a demand.

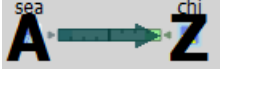
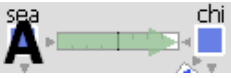
Table 26-6 Demand Visualization (continued)

Graphic	Description
	Shortest latency path of a demand.
	Multicast flow and multicast flow hops. See the Multicast Simulation chapter.





Demand Segment Lists

Table 26-7 Demand Segment List Visualization

Graphic	Description
For more information, see the Segment Routing Simulation chapter.	
	Site containing a node segment in a demand's segment list.
	Node segment in a demand's segment list.
	Interface segment in a demand's segment list.
	Site containing the source of an LSP segment in a demand's segment list.
	Source node of an LSP segment in a demand's segment list.
	Site containing one or more nodes belonging to an anycast group segment in a demand's segment list.
	Node belonging to an anycast group in a demand's segment list.

External Endpoint Members

Table 26-8 External Endpoint Visualization

Graphic	Description
	Failed external endpoint member.
	External endpoint member is not operational because it is contained in a failed SRLG.
	External endpoint member is not active.
	External endpoint member is not operational because it is contained in an SRLG that is not active.

LSPs

For more information on LSPs, see the [MPLS Simulation](#), [RSVP-TE Simulation](#), and [Segment Routing Simulation](#) chapters.

Table 26-9 LSP Visualization









Graphic	Description
	"A" and "Z" mark source and destination site/node of an LSP. Brown arrows show how LSP traffic is routed.
	Rerouting of an LSP traffic when a failure occurs in Convergence mode
	Fast Reroute (FRR) LSP path that would be taken if there were a failure that required its use.
	FRR LSP that is currently rerouting LSP traffic around a failure in FRR mode.
	Shortest IGP path of an LSP.

Table 26-9 LSP Visualization (continued)

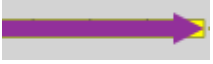
Graphic	Description
	Shortest latency path of an LSP.
	Shortest TE path of an LSP.

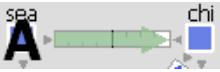
LSP Paths

Table 26-10 LSP Path Visualization

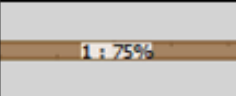
Graphic	Description
	"A" and "Z" mark source and destination site/node of an LSP path. The brown arrow indicates the LSP path is active, that is, carrying traffic. The number in the gray rectangle (here 1) is the path option.
	A lighter brown arrow indicates the LSP path is not active and is not carrying traffic. The yellow rectangle indicates a standby path. The number in a yellow rectangle (here 2) is the path option.
	The percent value is the loadshare percentage that this LSP path is carrying for the selected LSP. In this example, the LSP loadshare percentage is 75%.

LSP Named Paths

Table 26-11 LSP Named Path Visualization









Graphic	Description
	"A" marks the source of a named path. The brown diamond on an interface denotes it as a named path hop. A black dot in the center denotes a strict hop.
	A brown diamond on a site denotes that the site contains a node or interface that is a named path hop. No black dot in the center denotes a loose hop. The site is shown as containing a loose hop unless all hops within the site are set to strict or exclude.
	A brown diamond on a node denotes it as a named path hop. No black dot in center denotes a loose hop.

Table 26-11 LSP Named Path Visualization (continued)

Graphic	Description
	"A" marks the source of a named path. A red circle with a white X on an interface denotes it as a named path hop that is set to <i>exclude</i> .
	A red circle with a white X on a site denotes that the site contains a named path hop on a node or interface and that it is set to <i>exclude</i> .
	A red circle with a white X on a node denotes it as a named path hop that is set to <i>exclude</i> .

LSP Actual Paths

Table 26-12 LSP Actual Path Visualization

Graphic	Description
	A dark brown circle on an interface denotes an LSP actual path hop on the interface.
	A dark brown circle on site denotes an actual path hop on a node or interface within the site.
	A dark brown circle on a node denotes an actual path hop on the node.

Segment-Routed LSP Paths

Table 26-13 SR LSP Path Visualization





Graphic	Description
	An interface segment in a segment-routed (SR) LSP.
	A site containing a node segment or an interface segment.
	A node segment in an SR LSP.

Table 26-13 SR LSP Path Visualization (continued)

Graphic	Description
	A site containing one or more nodes belonging to an anycast group.
	Node belonging to an anycast group.

L1 Objects

For more information, see the [Layer 1 Simulation](#) chapter.

L1 Links

Table 26-14 Layer 1 Link Visualization







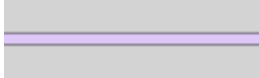
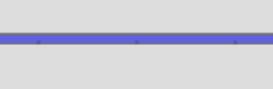

Graphic	Description
	Unselected L1 link. In the L1 Failure Impact view, indicates that failing the L1 link would not increase the traffic utilization on any L3 circuit.
	Selected L1 link.
	In the L1 Failure Impact view, the color represents the failure impact of an L1 link. This is defined as the highest utilization experienced by any L3 interface if that L1 link were to fail.
	L1 link failed.
	L1 link is not operational because of one of the following reasons. <ul style="list-style-type: none"> • L1 node failed that is connected to the L1 link. • A site failed that contains the L1 link. • An SRLG failed that contains the L1 link. • An SRLG failed that contains an L1 node connected to the L1 link.

Table 26-14 Layer 1 Link Visualization (continued)

Graphic	Description
	L1 link is inactive.
	L1 link is inactive for one of the following reasons. <ul style="list-style-type: none"> An L1 node that is connected to the L1 link is inactive. An inactive SRLG contains the L1 link.
	Multi-layer view—A blue dotted line indicates an L3-L1 link.
	Multi-layer view—A solid, thin gray line indicates a selected L3-L1 link.

L1 Circuit Paths

Table 26-15 Layer 1 Circuit Path Visualization







Graphic	Description
<p>Active Sim Path</p> 	<p>Simulated L1 circuit path from L1 node “A” to L1 node “B” highlights in green when any of the following are selected.</p> <ul style="list-style-type: none"> L1 circuit or L1 circuit path Circuit or associated interface mapped to L1 circuit Port circuit mapped to L1 circuit <p>The simulated active path appears in a darker green than simulated paths that are not active.</p>
<p>Sim Path</p> 	
<p>Standby Path</p> 	<p>Path options are numerically identified within a rectangular label. Standby paths have a yellow background, and non-standby paths have a gray background. In this example, path option 2 is a standby path, and path option 3 is a non-standby path.</p>
<p>Non-Standby Path</p> 	

Table 26-15 Layer 1 Circuit Path Visualization

Graphic	Description
	Actual L1 circuit path.
	Shortest latency of an L1 circuit path
	Rerouted L1 circuit path that is in use.
	Unrouted L1 circuit path.

L1 Circuit Path Hops

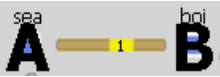
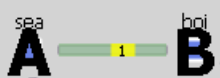
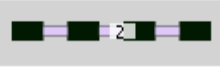
Table 26-16 L1 Circuit Path Hop Visualization









Graphic	Description
	L1 link is a strict L1 circuit path hop.
	Site contains an L1 node that is a strict L1 circuit path hop.
	L1 node is a strict L1 circuit path hop.
	Site contains an L1 node that is a loose L1 circuit path hop.
	L1 node is a loose L1 circuit path hop.
	L1 link is an excluded L1 circuit path hop.

Table 26-16 L1 Circuit Path Hop Visualization

Graphic	Description
	Site contains an L1 node that is excluded as an L1 circuit path hop.
	L1 node is excluded as an L1 circuit path hop.

L1 Nodes, L1 Ports, and L1 Waypoints

Table 26-17 Layer 1 Node, L1 Port, and L1 Waypoint Visualization













Graphic	Description
	An L1 node is shown as a blue rectangle without borders.
	A selected L1 node is a darker shade of blue.
	L1 Failure Impact view—The color represents the failure impact of an L1 node. This is defined as the highest utilization experienced by any L3 interface if that L1 node were to fail.
	InL1 Failure Impact view—Indicates that failing the L1 node would not increase the traffic utilization on any L3 circuit.
	L1 node failed.
	L1 port failed.
	L1 node is not operational because it is contained in a failed site or SRLG.
	L1 node is inactive.
	L1 port is inactive.
	L1 node is not operational because an SRLG containing it is inactive.

Table 26-17 *Layer 1 Node, L1 Port, and L1 Waypoint Visualization*

Graphic	Description
 A small graphic showing a purple cylindrical link with a purple dot in the center, representing an L1 link waypoint.	L1 link waypoint.
 A small graphic showing a purple cylindrical link with a blue dot in the center, representing a selected L1 link waypoint.	Selected L1 link waypoint.

