



Appendix

- Cisco VIM Wiring Diagrams, on page 1

Cisco VIM Wiring Diagrams

Figure 1: M4-Micropod with Cisco VIC

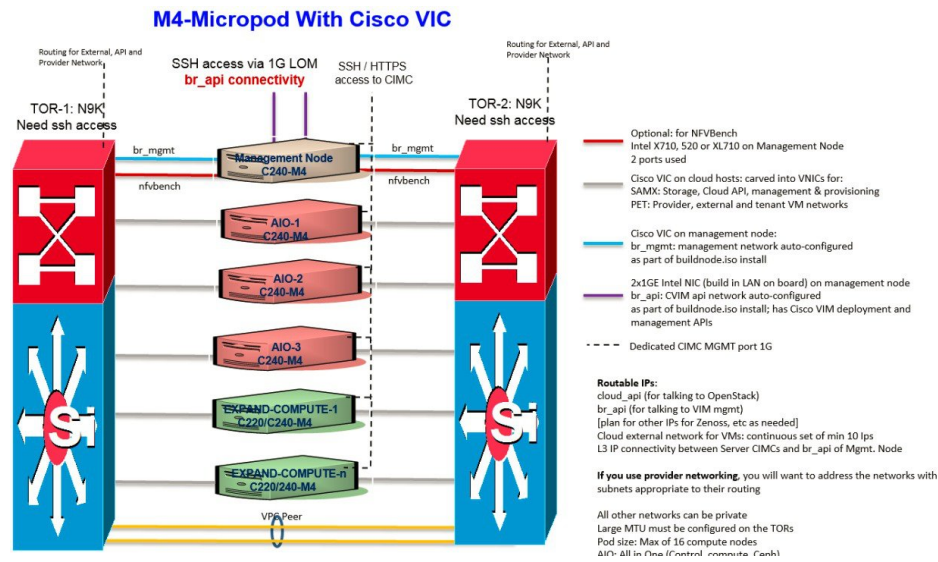

Figure 2: M4-Full-On with Cisco VIC

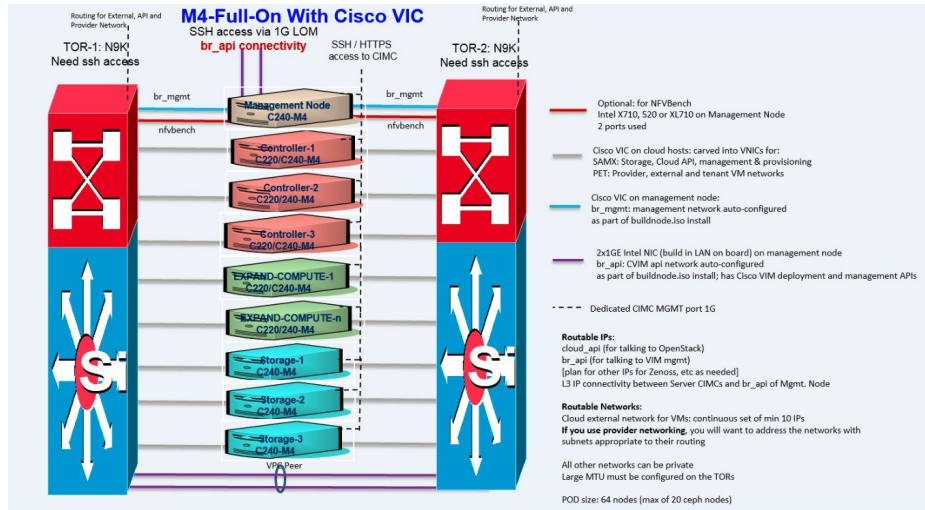

Figure 3: M4 Micropod with Intel NIC (X710) - NIC Redundancy

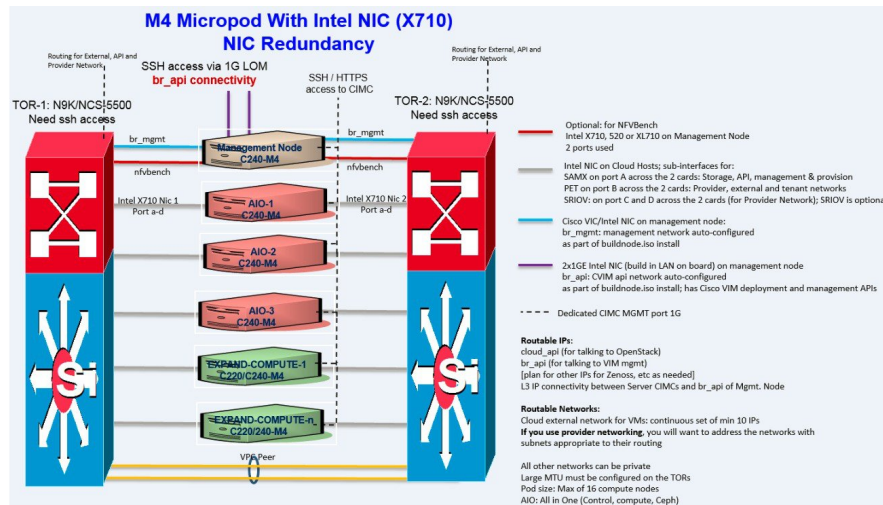

Figure 4: NGENA HC: M4-Full-On with Cisco VIC/NIC (1xX710) VPP based; no SRIOV

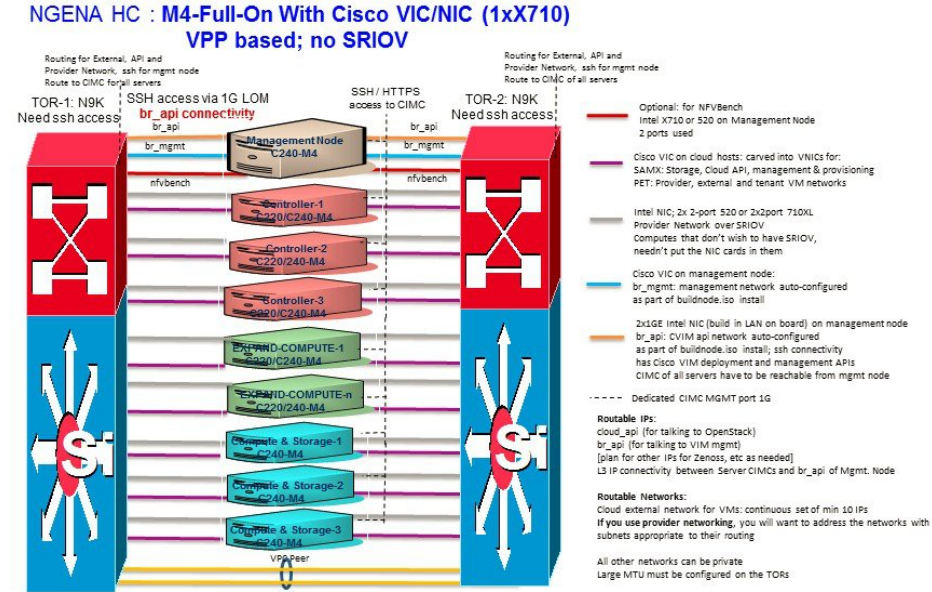

Figure 5: M5-Micropod with Intel NIC (X710) - No NIC Redundancy

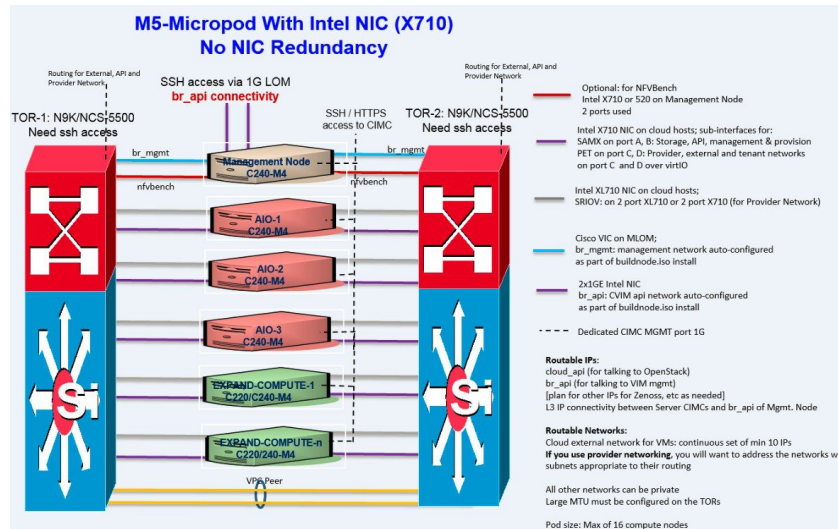

Figure 6: M4/M5 Full-On with Intel NIC (X710) and with NIC Redundancy

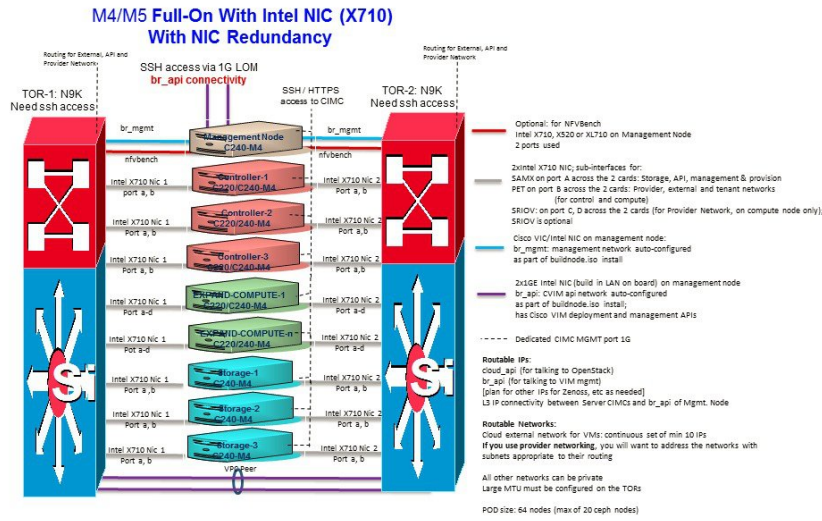

Figure 7: M4/M5 Full-On with Cisco VIC/NIC (2xXL710/2x520)

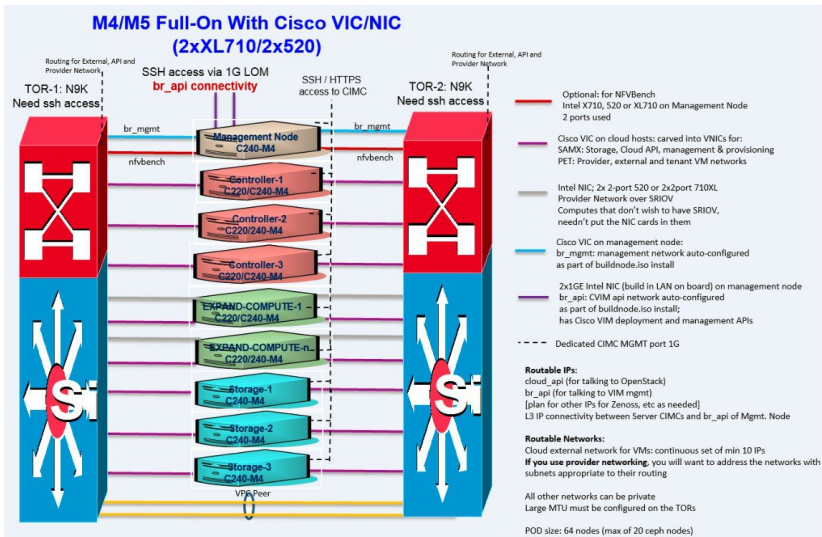

Figure 8: M4/M5 Micropod with Cisco VIC/NIC (2xXL710/2x520)

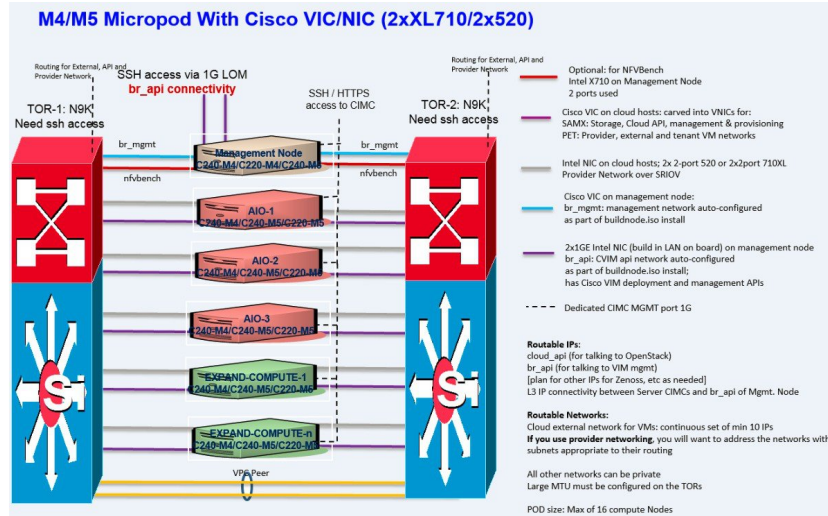

Figure 9: M4/M5-HC with Cisco VIC/NIC (2xXL710/2x520)

