



# Installing the Cisco Prime NAM 2404 Appliance

---

This chapter provides the information you need to install your Cisco Prime NAM 2404 appliance, including how to install hardware options, how to mount the NAM appliance in a rack, cabling, and how to connect it to the network.

These instructions are intended for technicians who are experienced with installing, replacing, and removing the hardware components from electronic devices and are familiar with the Cisco Prime NAM 2404 appliance. Additionally, site planners, network administrators, and facility maintenance personnel might also find this information helpful.

The installation and replacement of the hardware components of the Cisco Prime NAM 2404 appliance involve many steps, most of which must be done in the order in which they are presented here. Each section explains one associated group of tasks upon which the next section's tasks are built.

This chapter contains the following sections:

- [Requirements and Restrictions, page 2-2](#)
- [Installation Process Summary, page 2-2](#)
- [Unpack and Inspect the Appliance, page 2-4](#)
- [Install the Appliance in a Rack, page 2-5](#)
- [Install the Transceiver Modules, page 2-6](#)
- [Connect the Power, page 2-7](#)
- [Connect the Appliance Cables, page 2-8](#)
- [Power Up the Appliance, page 2-12](#)

# Requirements and Restrictions

This section contains the requirements that are necessary for the product to run successfully:

- Plan your site configuration and prepare the site before installing the appliance. Cisco Prime NAM 2404 appliance come preinstalled on a Cisco UCS C220 server, so for the recommended site planning tasks, see the [Cisco UCS Site Preparation Guide](#).
- For physical, environmental, and power requirements, including thermal (air conditioning), space, and power requirements, see [Appendix C, “Technical Specifications”](#). If available, you can use an uninterruptible power supply (UPS) to protect against power failures.



**Caution**

Avoid UPS types that use ferroresonant technology. These UPS types can become unstable with systems such as the Cisco UCS, which can have substantial current draw fluctuations from fluctuating data traffic patterns.

- Ensure that the cabinet or rack meets the requirements listed in the section, see [Install the Appliance in a Rack, page 2-5](#).

# Installation Process Summary

This section provides a summary of how to prepare and install the Cisco Prime NAM 2404 appliance .



**Warning**

**Read the installation instructions before connecting the system to the power source.** Statement 1004



**Warning**

**Installation of the equipment must comply with local and national electrical codes.** Statement 1074



**Warning**

**Only trained and qualified personnel should be allowed to install, replace, or service this equipment.** Statement 1030



**Warning**

**This unit is intended for installation in restricted access areas. A restricted access area can be accessed only through the use of a special tool, lock and key, or other means of security.** Statement 1017



**Warning**

**Power off the unit before you begin.** Statement 237

**Warning**

To prevent personal injury or damage to the chassis, never attempt to lift or tilt the chassis using the handles on modules (such as power supplies, fans, or cards); these types of handles are not designed to support the weight of the unit. Statement 1032

**Warning**

Do not touch the power supply when the power cord is connected. For systems with a power switch, line voltages are present within the power supply even when the power switch is off and the power cord is connected. For systems without a power switch, line voltages are present within the power supply when the power cord is connected. Statement 4

**Warning**

To prevent bodily injury when mounting or servicing this unit in a rack, you must take special precautions to ensure that the system remains stable. The following guidelines are provided to ensure your safety:

- This unit should be mounted at the bottom of the rack if it is the only unit in the rack.
- When mounting this unit in a partially filled rack, load the rack from the bottom to the top with the heaviest component at the bottom of the rack.
- If the rack is provided with stabilizing devices, install the stabilizers before mounting or servicing the unit in the rack. Statement 1006

- 
- Step 1** Review the following:
- [Regulatory Compliance and Safety Information for the Cisco UCS C-Series Servers](#)
  - [Appendix B, “Safety Guidelines”](#)
- Step 2** Unpack and inspect each of the components for possible damage that might have occurred during shipping. Ensure that you have all required components.  
See [Unpack and Inspect the Appliance, page 2-4](#).
- Step 3** Install the Cisco Prime NAM 2404 appliance in a rack.  
See [Install the Appliance in a Rack, page 2-5](#).
- Step 4** Install the transceiver modules.  
See [Install the Transceiver Modules, page 2-6](#).
- Step 5** Connect the appliance to a power source.  
See [Connect the Power, page 2-7](#).
- Step 6** Connect the appliance cables.  
See [Connect the Appliance Cables, page 2-8](#)
- Step 7** Turn on the power.  
See [Power Up the Appliance, page 2-12](#)
-

After completing the hardware installation, configure the appliance. See [Chapter 3, “Configuring the Cisco Prime NAM 2404 Appliance.”](#)

## Unpack and Inspect the Appliance



### Caution

When handling internal appliance components, wear an ESD strap and handle modules by the carrier edges only.



### Tip

Do not remove the appliance from its shipping container until you are ready to install it.



### Tip

Do not discard the packaging materials used in shipping your Cisco Prime NAM 2404 appliance. You will need the packaging materials in the future if you move or ship your appliance.



### Note

The chassis is thoroughly inspected before shipment. If any damage occurred during transportation or any items are missing, contact your customer service representative immediately.

To unpack and inspect the shipment:

- 
- Step 1** Remove the appliance from its cardboard container and save all packaging material.
- Step 2** Compare the shipment to the equipment list. Verify that you have all items.
- The appliance, cables, and any optional equipment you ordered might be shipped in more than one container. When you unpack the containers, check the items against the packing list (see [Table 2-1](#)) to verify that you received all the parts.
- Step 3** Check for damage and report any discrepancies or damage to your customer service representative. Have the following information ready:
- Invoice number of shipper (see the packing slip)
  - Model and serial number (see [Serial Number Locations, page A-4](#)) of the damaged unit
  - Description of damage
  - Effect of damage on the installation
-

## Cisco Prime NAM 2404 Appliance Packing List

The following table lists the items that ship with the Cisco Prime NAM 2404. A *Notes* section has been provided to record damaged or missing items.

**Table 2-1** Cisco Prime NAM 2404 Appliance Packing List

✓	Item
<input type="checkbox"/>	Cisco Prime NAM 2404 is pre-installed on a Cisco UCS C220 server
<input type="checkbox"/>	Power cable (customer chosen)
<input type="checkbox"/>	Cable assembly, Ethernet, RJ45-RJ45, Yellow, 6 ft.
<input type="checkbox"/>	CABASY, Console, RJ45/DB9
<input type="checkbox"/>	CABASY, RF, MICRO MINITURE, FOX 36P, 9P DSUB, USB, DONGLE CABLE
<input type="checkbox"/>	ASY, MECH, RAIL KIT, 1RU, SAVBU
<input type="checkbox"/>	<i>Cisco Prime NAM Documentation Roadmap</i>

## Install the Appliance in a Rack

The rack must be of the following type:

- A standard 19-in. (48.3-cm) wide, four-post EIA rack, with mounting posts that conform to English universal hole spacing, per section 1 of ANSI/EIA-310-D-1992.
- The rack post holes can be square .38-inch (9.6 mm), round .28-inch (7.1 mm), #12-24 UNC, or #10-32 UNC when you use the supplied slide rails.
- The minimum vertical rack space per appliance must be one RU, equal to 1.75 in. (44.45 mm).

The slide rails supplied by Cisco Systems for this appliance do not require tools for installation. The inner rails (mounting brackets) are pre-attached to the sides of the appliance.

Because the Cisco Prime NAM 2404 appliance come pre-installed on a Cisco UCS C220 server, see The [Installing the Server In a Rack](#) section in the Cisco UCS C220 M4 Server Installation and Service Guide for the recommended rack mounting tasks for Cisco Prime NAM 2404 Appliance.

# Install the Transceiver Modules

You can order SFP transceiver modules as hardware options or you can use modules you might already own as long as they meet the specifications described in the [data sheets](#) on Cisco.com. Because these modules are delicate devices, they are packaged separately and are not installed in the appliance prior to shipping.



**Caution** Do not add labels or markings to the modules.

[Figure 2-1](#) shows a detailed view of an SFP module installation.

**Figure 2-1** Installing an SFP Module

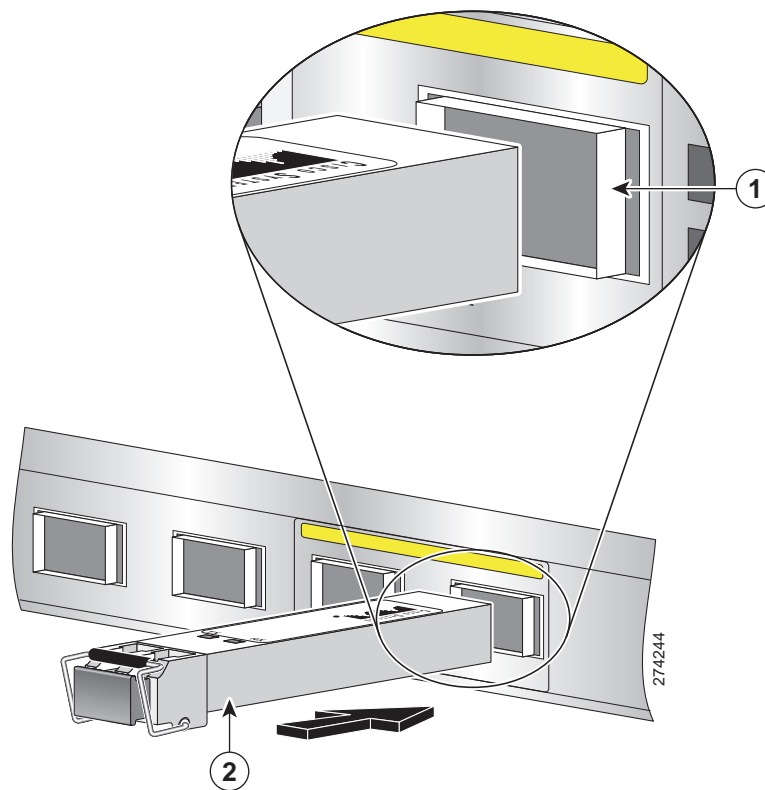

<b>1</b>	SFP slot in back panel	<b>2</b>	SFP positioned for back panel slot
----------	------------------------	----------	------------------------------------

To install an SFP module in a Cisco Prime NAM 2404 appliance:

- Step 1** Locate the transceiver module you plan to install and remove any protective packaging.
- Step 2** Determine into which of the two slots on the rear panel of the NAM appliance you will install the module.

The SFP modules use the bail clasp latching mechanism as shown unlatched in [Figure 2-2](#) and latched in [Figure 2-3](#).

- Step 3** With its latch open, slide the module into the slot until you feel resistance, then push it harder until you feel (or hear) it click into its socket.

Figure 2-2 shows an example of a transceiver module with its latch open.

*Figure 2-2 Transceiver Module (unlatched)*

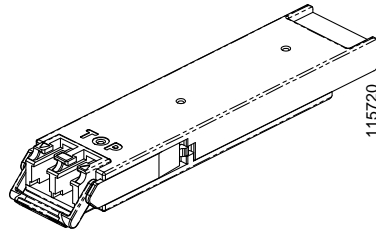

- Step 4** With your finger, pull the latch upwards to lock the module into its slot.

*Figure 2-3 Transceiver Module (latched)*

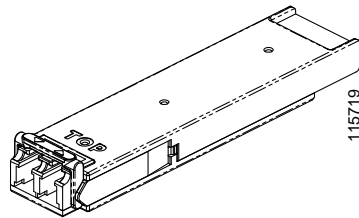

- Step 5** Plug in the fiber optical cable.
- Step 6** Observe the front-panel LEDs to verify that the connection is operating properly. (See “[Reading the LEDs](#)” section on page 5-1.)

---

To replace a transceiver module, see [Replacing Transceiver Modules, page 5-9](#).



---

**Note** If you use NIC card with RJ45 ports, do not install the transceiver modules.

---

## Connect the Power

When installing the NAM appliance, use the AC power cord that was shipped with the Cisco Prime NAM 2404 appliance.

The AC power cord is considered the primary disconnect for the appliance and must be readily accessible when installed. If the appliance power cord is not readily accessible to be disconnected, you must install an AC power disconnect for the entire rack. This disconnect must be readily accessible, and it must be properly labeled as the controlling power to the entire rack, not just to the appliance.

To connect the AC power to the Cisco Prime NAM 2404 appliance :

- Step 1** Review the [Safety with Electricity](#) information in the [Safety Guidelines](#) appendix.

**Step 2** Ground the rack.

To avoid the potential for an electrical shock, you must include a third wire safety ground conductor with the rack installation. If the appliance power cord is plugged into an AC outlet that is part of the rack, you must provide proper grounding for the rack itself. If the appliance power cord is plugged into a wall outlet, the safety ground conductor in the power cord provides proper grounding only for the appliance. You must provide additional, proper grounding for the rack.

**Step 3** Plug the AC power cord into the AC power input connector at the rear of the appliance , and the other end of the power cord to a power source at your site.

The AC power cord is considered the primary disconnect for the appliance and must be readily accessible when installed. If the appliance power cord is not readily accessible to be disconnected, you must install an AC power disconnect for the entire rack. This disconnect must be readily accessible, and it must be properly labeled as the controlling power to the entire rack, not just to the appliance.



---

**Caution** *Do not* power on the unit yet.

---

## Connect the Appliance Cables

This section describes how to connect cables to your Cisco Prime NAM 2404 appliance . It includes the following topics:

- [Connect the Management Port](#)
- [Connect the Monitoring Ports](#)
- [Connect a Console Terminal](#)
- [Connect a Monitor to the Appliance](#)

## Connect the Management Port

The Cisco Prime NAM 2404 appliance management port is the LAN 1 port, an RJ-45 10BASE-T/100BASE-TX/1000BASE-T network interface connector.

To connect the Cisco Prime NAM 2404 appliance management port:

- 
- Step 1** Connect one end of a Cat5e (or better) Ethernet cable to the LAN 1 port on the appliance.
- Step 2** Connect the other end of the cable to a hub or switch (a gateway) in your network.
- Step 3** After connecting the management port, observe the LEDs to verify that the connection is operating properly. (See [Status LEDs and Buttons Section](#) in the Cisco UCS C220 M4 Server Installation and Service Guide.)
-



## Connect the Monitoring Ports

You can connect the Cisco Prime NAM 2404 appliance directly to a device to monitor, such as a switch or router, or you can connect a NAM appliance between two devices using an optical tap device. The following topics describe these connection methods:

- [Direct Connections](#)
- [Optical Tap Connections](#)

### Direct Connections

In a typical NAM installation, the Cisco Prime NAM 2404 appliance receives switch or router traffic from the SPAN ports of the remote device.

To connect the Cisco Prime NAM 2404 appliance directly to a device you want to monitor, such as a switch or router:

- Step 4** Run a fiber optical cable from the port on the remote device to the transceiver module in the back panel of the Cisco Prime NAM 2404 appliance. After connecting the appliance, observe the LEDs on the Napatech NIC to verify that the connection is operating properly. (See [“Reading the LEDs”](#) section on page 5-1.)



---

**Note** You can only use the Ethernet cables, if you are using NIC with RJ45 / copper ports.

---

### Optical Tap Connections

Another possible NAM installation enables you to monitor traffic between two devices by locating the Cisco Prime NAM 2404 appliance between the two devices. Using traffic tapping, the network tap passes the traffic between the two devices while mirroring each direction of traffic to one of the NAM data ports.

You can connect the Cisco Prime NAM 2404 appliance between two remote devices using the NIC with optical interface - SFP. It also uses the Ethernet taps for connections. For more information, see the respective Ethernet tap user guides for connection details. The optical tap mirrors the transmit sides of the cable that connects two remote devices as shown in [Figure 2-4](#).



---

**Note** The optical tap connection requires two additional fiber optical cables.

---

Figure 2-4 Optical Tap Connection

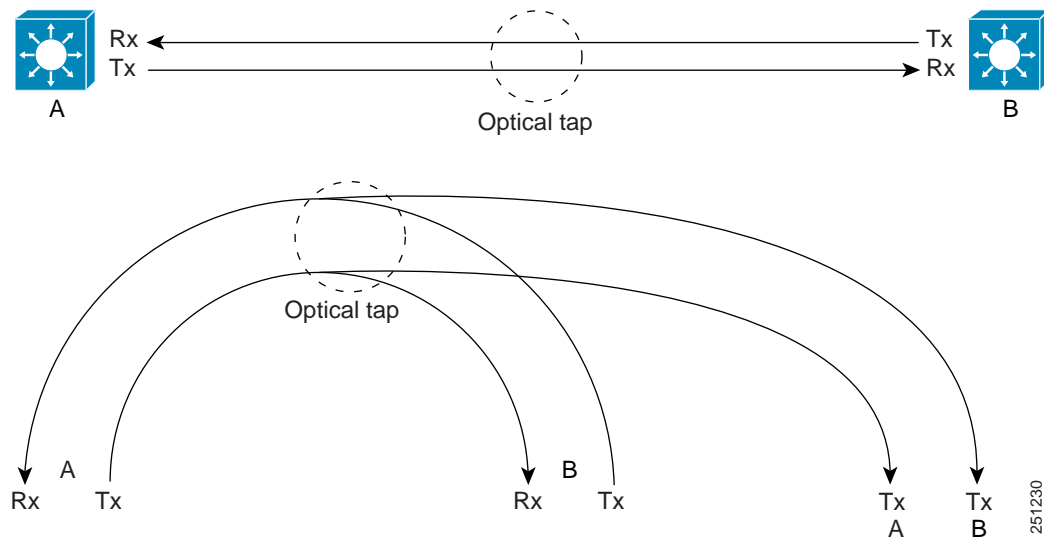

**Note** You can find optical tap and cable specifications in [Appendix C, “Technical Specifications.”](#)

To use an optical tap to connect the Tx signals of two devices to the Cisco Prime NAM 2404 appliance monitoring ports:

- Step 1** Disconnect the 1 GbE fiber optical cable that connects the two devices and plug the disconnected end of the cable into the appropriate ports on the optical tap for Device A.
- Step 2** Plug another 1 GbE fiber optical cable into the output port for Device B, then plug the other end into the appropriate ports on the optical tap for Device B.
- Step 3** Run a third 1 GbE fiber optical cable from the Tx A/Tx B ports on the optical tap device to the Cisco Prime NAM 2404 appliance .
- Step 4** At the Cisco Prime NAM 2404 appliance , separate the connectors at the end of the 1 GbE fiber optical cable.

The two connectors of the 1 GbE fiber optical cable plug into different SFPs enabling the appliance to monitor all traffic between the two devices. See [Figure 2-5](#) for an illustration of the fiber optical cable inputs to the SFPs for an optical tap configuration.

**Figure 2-5** *Fiber Optical Cable Inputs for Optical Tap Configuration*

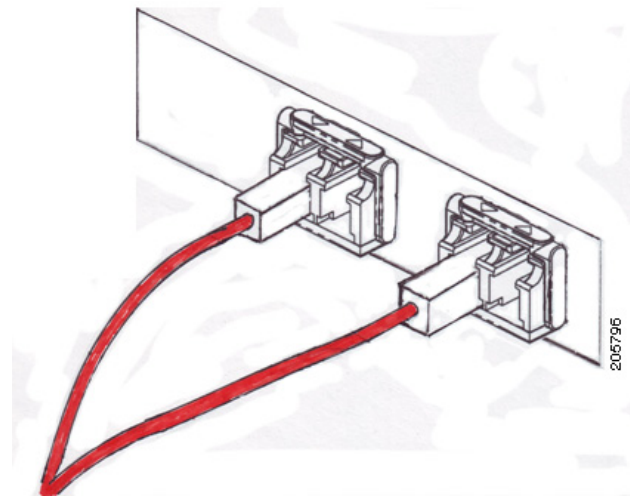

- Step 5** Plug Device A's Tx connector into the left side of the SFP on the right (logical DataPort1).
- Step 6** Plug the Device B Tx connector into the left side of the SFP on the left (logical DataPort2).

To use breakout mode configuration, use an optical tap to split the Tx and Rx signals of two connected devices so the NAM appliance receives the Tx of both devices to observe the transmitted output of each device.

There are two breakout mode configurations:

- Tx of one direction of the monitored data traffic is replicated on Tx of one breakout port and Tx of the other direction of the monitored data traffic is replicated on Tx of the other breakout port.

This case provides two output replicated ports: one for Tx in one direction and one for Tx of the other direction. Each replicated port is an input to a different monitoring port of the appliance to monitor both directions of traffic.

- Tx of one direction of the monitored data traffic is replicated in one Tx connection of the breakout port and Tx of the other direction of the monitored data traffic is replicated on the other Tx connection of the same breakout port.

This case provides only one replicated port which has Tx of both directions. This case requires you to split the connectors of one fiber optical cable and put one connector into one appliance monitoring port and put the other connector into a different appliance monitoring port.

## Connect a Console Terminal

You can connect a console terminal using a PC running terminal-emulation software to the console port on the Cisco Prime NAM 2404 appliance in either of two ways:

- Connect the terminal using a rollover cable to the appliance console port (see [Figure 1-2](#)).  
The rollover cable is provided in the cables shipped with your appliance.
- Connect a terminal server to the appliance console port.

After connecting the console terminal, observe the front-panel LEDs to verify that the connection is operating properly. (See [“Reading the LEDs” section on page 5-1.](#))

Configure your terminal or terminal-emulation software as shown in [Table 2-2.](#)

*Table 2-2 Terminal Configuration*

Baud rate	9600
Data bits	8
Parity	No
Stop bit	1
Hardware flow control	Off

## Connect a Monitor to the Appliance

You might want to connect a monitor to the Cisco Prime NAM 2404 appliance, but it is not required; you can establish a console connection to the NAM appliance in other ways. The Cisco Prime NAM 2404 appliance supports a VGA monitor.

The VGA monitor connector is located on the back panel of the appliance (see [Figure 1-2.](#))

After connecting the monitor cable, observe the front-panel LEDs to verify that the connection is operating properly. (See [“Reading the LEDs” section on page 5-1.](#))

## Power Up the Appliance

After you have completed all connections for the Cisco Prime NAM 2404 appliance, you can turn on AC power. The power switch is located on the front panel.

After the operating system boots up, observe the front-panel LEDs to verify that your system is operating properly. (See [“Reading the LEDs” section on page 5-1.](#))