



CHAPTER 3

Installing the Cisco NAM 2220 Appliance

This chapter provides the information you need to install your Cisco NAM 2220 appliance, including how to install hardware options, how to mount the appliance in a rack, cabling, and how to connect it to the network.

This chapter contains the following sections:

- [Installation Overview, page 3-2](#)
- [Installing the XFP Transceiver Module, page 3-3](#)
- [Rack-Mounting Configuration Guidelines, page 3-3](#)
- [Mounting the Cisco NAM 2220 Appliance in a 4-Post Rack, page 3-4](#)
- [Cisco NAM 2220 Appliance Power, page 3-9](#)
- [Connecting Appliance Cables, page 3-11](#)
 - [Connecting the Management Port, page 3-12](#)
 - [Connecting a Console Terminal, page 3-12](#)
 - [Connecting the Monitoring Ports, page 3-13](#)
- [Powering Up the Cisco NAM 2220 Appliance, page 3-16](#)
- [Removing or Replacing the Cisco NAM 2220 Appliance, page 3-18](#)

Before you begin the installation, read the *Regulatory Compliance and Safety Information for the Cisco NAM 2200 Series Appliance* document and the *Site Preparation and Safety Guide* that shipped with your appliance.

http://www.cisco.com/en/US/docs/net_mgmt/network_analysis_module_appliance/regulatory/compliance/nam2200rcsi.html

Warning

Read the installation instructions before you connect the system to its power source. Statement 10

Warning

Only trained and qualified personnel should be allowed to install, replace, or service this equipment. This equipment contains an energy hazard. Disconnect the system before servicing. Statement 186

Warning

This unit is intended for installation in restricted access areas. A restricted access area can be accessed only through the use of a special tool, lock and key, or other means of security. Statement 1017

**Warning**

Before working on a system that has an on/off switch, turn OFF the power and unplug the power cord. Statement 1

**Warning**

To prevent personal injury or damage to the chassis, never attempt to lift or tilt the chassis using the handles on modules (such as power supplies, fans, or cards); these types of handles are not designed to support the weight of the unit. Statement 1032

**Warning**

Do not touch the power supply when the power cord is connected. For systems with a power switch, line voltages are present within the power supply even when the power switch is off and the power cord is connected. For systems without a power switch, line voltages are present within the power supply when the power cord is connected. Statement 4

**Warning**

To prevent bodily injury when mounting or servicing this unit in a rack, you must take special precautions to ensure that the system remains stable. The following guidelines are provided to ensure your safety:

- **This unit should be mounted at the bottom of the rack if it is the only unit in the rack.**
- **When mounting this unit in a partially filled rack, load the rack from the bottom to the top with the heaviest component at the bottom of the rack.**
- **If the rack is provided with stabilizing devices, install the stabilizers before mounting or servicing the unit in the rack.** Statement 1006

Installation Overview

This section provides a step-by-step procedure to help guide you through the installation of the Cisco NAM 2220 appliance.

Step 1 Open box in which the Cisco NAM 2220 appliance was shipped, and inspect each of the components for possible damage that might have occurred during shipping. Ensure that you have all required components.

Step 2 Review all safety information.

You can find safety information in this document at the following locations:

- [Safety Warnings](#), in "About This Guide"
- [Safety Guidelines](#), in Chapter 3, "Installing the Cisco NAM 2220 Appliance"

You can also find safety information in *The Regulatory Compliance and Safety Information for the Cisco NAM 2200 Series Appliances* (78-18308-01) which shipped with your Cisco NAM 2220 appliance and is available online at the following URL:

http://www.cisco.com/en/US/docs/net_mgmt/network_analysis_module_appliance/regulatory/compliance/nam2200rcsi.html

- Step 3** Install the Cisco NAM 2220 appliance in a rack.
See [Rack-Mounting Configuration Guidelines, page 3-3](#) and [Mounting the Cisco NAM 2220 Appliance in a 4-Post Rack, page 3-4](#) for more information.
- Step 4** Install the XFP transceiver modules.
See [Installing the XFP Transceiver Module, page 3-3](#).
- Step 5** Connect the Cisco NAM 2220 appliance to a power source.
See [Cisco NAM 2220 Appliance Power, page 3-9](#).
- Step 6** Connect the Cisco NAM 2220 appliance network interface.
See [Connecting the Management Port, page 3-12](#)
- Step 7** Connect the Cisco NAM 2220 appliance console cable.
See [Connecting a Console Terminal, page 3-12](#)
- Step 8** Connect the Cisco NAM 2220 appliance to a remote device to monitor.
See [Connecting Appliance Cables, page 3-11](#)
- Step 9** Turn on power.
See [Powering Up the Cisco NAM 2220 Appliance, page 3-16](#)
-

This completes the hardware installation of the Cisco NAM 2220 appliance. After completing the hardware installation, configure the appliance. See [Chapter 5, “Configuring the Cisco NAM 2220 Appliance.”](#)

Installing the XFP Transceiver Module

The Cisco NAM 2220 appliance uses one or two 10 GB Ethernet XFP transceiver modules to connect fiber optical cables as data input sources. The XFPs can both be long range or both be short range, or you can install one of each. Depending on the type of XFP you use, you must use the correct fiber optical cables.

You can order XFPs as hardware options or you can use XFPs you might already own as long as they meet the specifications described in [XFP Modules, page B-1](#).

Because XFPs are delicate devices, they are packaged separately and are not installed in the appliance prior to shipping. See [Installing and Replacing XFP Transceiver Modules, page 4-3](#), for more information about XFPs and installation information in [Installing an XFP](#).

Rack-Mounting Configuration Guidelines

You can mid-mount the appliance in a 19-inch (48.3-cm) equipment rack that conforms to the 2- and 4-post rack specification (the inside width of the rack should be 17.5 inches [44.45 cm]). When installed in the rack, the appliance requires two EIA 3.5-inch (8.9-cm) vertical mounting spaces or 2 rack units (RU) for mounting. (See “[Mounting the Cisco NAM 2220 Appliance in a 4-Post Rack](#)” section on [page 3-4](#).)

**Caution**

Clearance in the front and rear of the Cisco NAM 2220 appliance must be allowed for cooling air to be drawn in through the front and circulated through the appliance and out the rear of the appliance.

The “[Rack Installation Safety Guidelines](#)” section on page 2-7 and the following information will help you plan your equipment rack configuration:

- When mounting the appliance to an equipment rack, ensure that the rack is bolted to the floor.
- Because you will probably be installing more than one appliance into the rack, ensure that the weight of all the appliances installed does not make the rack unstable.

**Caution**

Some equipment racks are also secured to ceiling brackets, if necessary, due to the weight of the equipment in the rack. Make sure that the rack you are using to install the appliances is secured to the building structure.

- As mentioned in the “[Airflow Guidelines](#)” section on page 2-8, maintain a 6-inch (15.2-cm) clearance at the front and rear of the appliance to ensure adequate air intake and exhaust.
- Avoid installing the appliances in an overly congested rack. Air flowing to or from other appliances in the rack might interfere with the normal flow of cooling air through the appliances, increasing the potential for overtemperature conditions within the appliances. (See the “[Overtemperature Protection \(OTP\)](#)” section on page 1-12 for more information about overtemperature conditions.)
- Allow at least 24 inches (61 cm) of clearance at the front and rear of the rack for appliance maintenance.

**Caution**

To prevent appliance overheating, never install the appliance in an enclosed rack or room that is not properly ventilated or air conditioned.

- Follow your local practices for cable management. Ensure that cables to and from the appliances do not impede access to perform equipment maintenance or upgrades.

Mounting the Cisco NAM 2220 Appliance in a 4-Post Rack

**Warning**

When the appliance is installed in a rack and is fully extended on its slide rail, it is possible for the rack to become unstable and tip over, which could cause serious injury. To eliminate the risk of rack instability from extending the rail or in the event of an earthquake, you should affix the rack to the floor.

This section contains the following topics:

- [4-Post Rack-Mount Hardware Kit, page 3-5](#)
- [Attaching the Inner Slide Rails and Rack-Mounting Ears to the Appliance, page 3-6](#)
- [Attaching the Outer Slide Rails to the Rack, page 3-7](#)
- [Installing the Appliance into the Rack, page 3-7](#)

4-Post Rack-Mount Hardware Kit

Figure 3-1 shows the rails and brackets that you need to install the Cisco NAM 2220 appliance in a 4-post rack. Figure 3-2 and Table 3-1 on page 3-5 describes the contents of the rack-mount hardware kit, Cisco part number NAM2220-RAILS.

Figure 3-1 4-Post Rails and Brackets

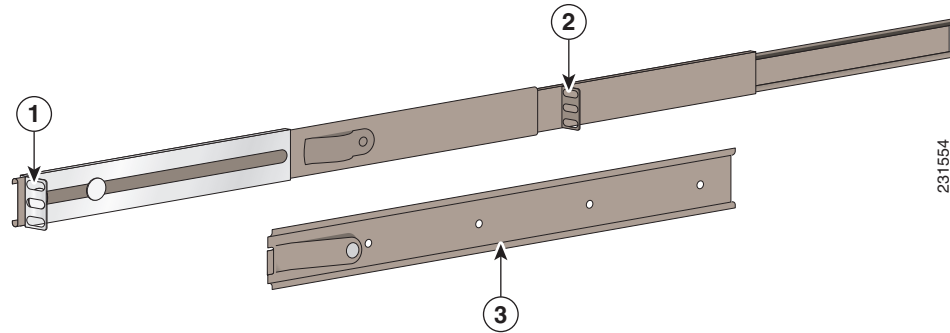

1	Rear-mounting bracket of outer slide rail	3	Inner slide rail
2	Front-mounting bracket of outer slide rail		

Figure 3-2 4-Post Rack-Mount Hardware Kit

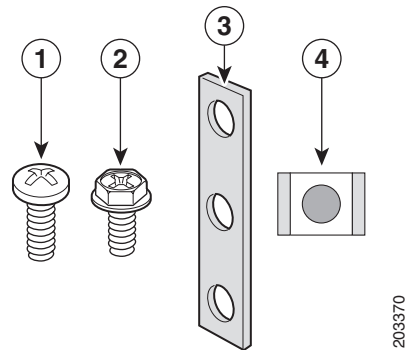

Table 3-1 4-Post Rack-Mount Hardware Kit

Item No.	Description	Quantity
1	Rack screw, 10-32 x 1/2-inch (1.27 cm)	12
2	Screw, 8-32 x 3/8-inch (.95 cm)	8
3	Nut bar ¹	4
4	Cage nut, 10-32 x 3/8-inch (.95 cm) ²	12
—	Screw, 6-32 x 1/4-inch (.63 cm) ³	8

1. Nut bar used in unthreaded round-hole racks or used over the cage nuts for square-hole racks.
2. Cage nuts are used only when mounting in square-hole racks.

3. Not shown in [Figure 3-2](#). Depending on rack type, can be used in place of 8-32 x 3/8-inch screws.

Attaching the Inner Slide Rails and Rack-Mounting Ears to the Appliance

To install the Cisco NAM 2220 appliance into the slide rails:

- Step 1** Align the inner slide rail holes with the horizontal holes on the side of the appliance beginning with the second hole. The release spring on the inner slide rail must point toward the rear of the appliance and face away from the appliance chassis. (See [Figure 3-3](#).)

Figure 3-3 *Aligning the Inner Slide Rail with the Mounting Studs*

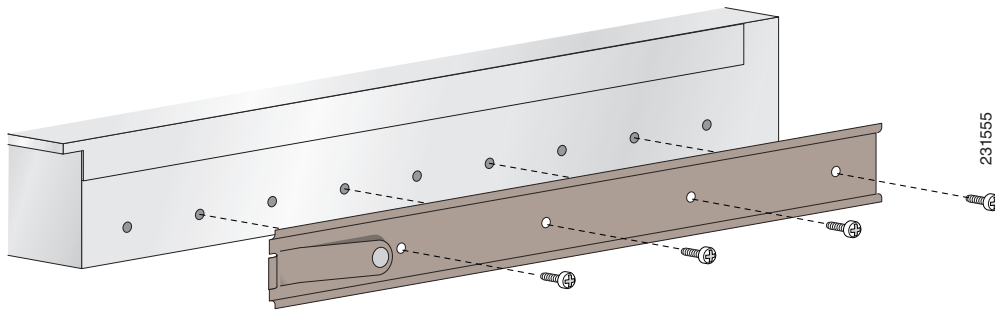

- Step 2** Attach the inner slide rail to the appliance with the 8-32 x 3/8-inch screws.
- Step 3** Attach the rack-mounting ear bracket to the two vertical holes located on the front of the appliance with 8-32 x 3/8-inch screws. (See [Figure 3-4](#).)

Figure 3-4 *Attaching the Rack-Mounting Ear Bracket to the Appliance*

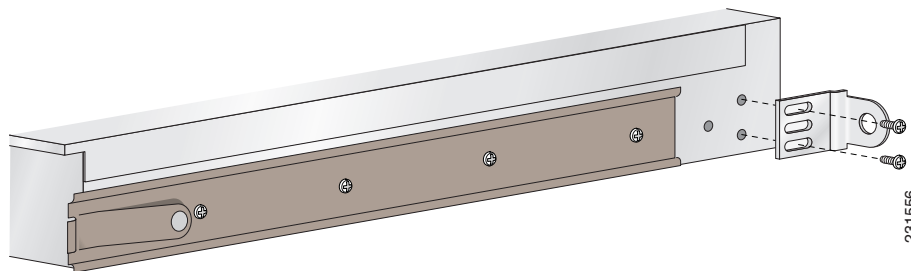

Caution

Failure to attach the mounting ear bracket to the appliance chassis could result in the appliance being pushed toward the rear of the rack during installation.

- Step 4** Repeat Steps 1 through 3 for the other inner slide rail and mounting ear bracket.
You are now ready to install the appliance into the 4-post rack.

Proceed to the next section, “[Attaching the Outer Slide Rails to the Rack](#),” to continue the installation.

Attaching the Outer Slide Rails to the Rack

**Caution**

Lifting the appliance and attaching it to the rack is a two-person job. If needed, use an appropriate lifting device. A fully loaded Cisco NAM 2220 appliance weighs approximately 51.5 lb (23.4 kg).

**Note**

This procedure describes the installation of the outer slide rails to a 4-post threaded-hole rack. If your 4-post rack uses rectangular holes, ensure that you have the proper adapters in place to secure the slide rails to the posts.

To attach the outer slide rails to the rack:

- Step 1** Determine the position on the rack where you want to mount the appliance.
- Step 2** Position the rear-mounting bracket on the outer side of the rear rack post and attach with the 10-32 x 1/2-inch rack screws.
- Step 3** Align the center end of the outer slide rail to the corresponding hole on the front rack post.
- Step 4** Attach the front-mounting bracket of the outer slide rail to the corresponding holes on the front rack post with the 10-32 x 1/2-inch rack screws.
- Step 5** Repeat Steps 2 through 4 for the other outer slide rail.

Proceed to the next section, “[Installing the Appliance into the Rack](#),” to continue the installation.

Installing the Appliance into the Rack

**Caution**

If you mount the outer slide rails in holes that are not vertically aligned from front to back, you might damage the slide rails and your mounting might not be secure.

To install the appliance into the rack:

- Step 1** Extend the inner slide rail until it locks into place.
- Step 2** Position the appliance so that the rear end of the inner slide rail aligns with the front end of the outer slide rails.
- Step 3** Slide the appliance into the rack.
You might need to press on the release spring. (See location 1 in [Figure 3-5](#).)

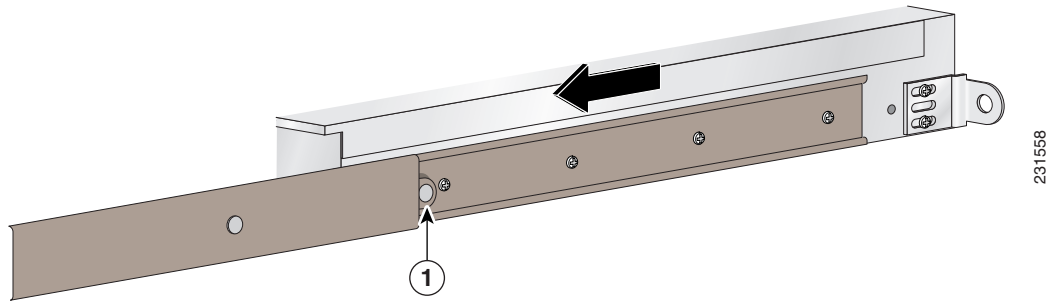
Figure 3-5 *Installing Appliance into Rack*

1	Release spring
----------	----------------

- Step 4** Slide the appliance until the release spring clicks into place, then push the appliance until the rack-mounting ear meets the front rack posts. (See location 1 in [Figure 3-6 on page 3-8](#).)

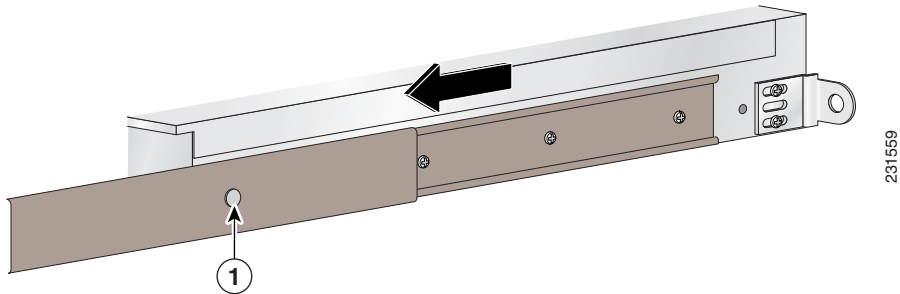
Figure 3-6 *Sliding Appliance into Rack*

- Step 5** (Optional) For extra security, you can attach a third 10-32 x 1/2-inch rack screw from the center of the rack-mounting ear into the front rack post. (See location 1 in [Figure 3-7](#).)

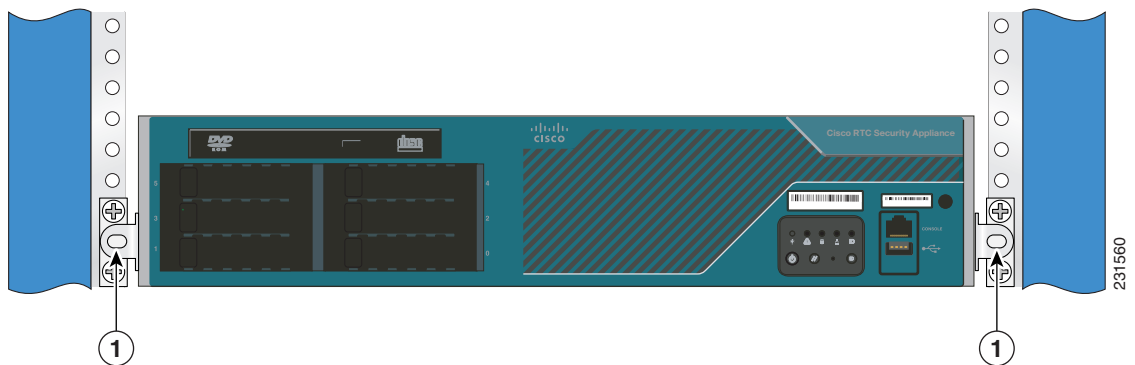
Figure 3-7 *Securing the Appliance to the Front Rack Posts*

1	Rack screw (10-32 x 1/2 inch)
---	-------------------------------

Proceed to the next section, “[Cisco NAM 2220 Appliance Power](#),” to continue the installation.

Cisco NAM 2220 Appliance Power

The Cisco NAM 2220 appliance uses an AC power supply.



Caution

To ensure proper cooling if only one power supply is installed, the power supply must be in the right-hand slot and the power supply blank filler panel must be in the left-hand slot. (See [Figure 4-22 on page 4-20](#).)



Warning

This equipment must be grounded. Never defeat the ground conductor or operate the equipment in the absence of a suitably installed ground conductor. Contact the appropriate electrical inspection authority or an electrician if you are uncertain that suitable grounding is available. Statement 1024



Warning

This product relies on the building’s installation for short-circuit (overcurrent) protection. Ensure that the protective device is rated not greater than: 10 Amps Statement 1005



Warning

Before working on a system that has an on/off switch, turn OFF the power and unplug the power cord. Statement 1



Warning

Do not touch the power supply when the power cord is connected. For systems with a power switch, line voltages are present within the power supply even when the power switch is off and the power cord is connected. For systems without a power switch, line voltages are present within the power supply when the power cord is connected. Statement 4



Warning

This unit might have more than one power supply connection. All connections must be removed to de-energize the unit. Statement 1028

Connecting the Appliance AC Power

When installing the appliance, use the AC power cord that was shipped with the Cisco NAM 2220 appliance.

The AC power cord is considered the primary disconnect for the appliance and must be readily accessible when installed. If the appliance power cord is not readily accessible to be disconnected, you must install an AC power disconnect for the entire rack. This disconnect must be readily accessible, and it must be properly labeled as the controlling power to the entire rack, not just to the appliance.

Power Connections

To connect the AC power cord to the Cisco NAM 2220 appliance:



Caution

If only one power supply is installed, it must be in the right-hand slot and a power supply blank filler panel must be installed in the left-hand slot to ensure proper cooling. (See location 10 in [Figure 3-8 on page 3-11](#).)

Step 1

Review the information in the [Safety Warnings](#) and the [Safety Guidelines](#) sections.



Warning

This equipment must be grounded. Never defeat the ground conductor or operate the equipment in the absence of a suitably installed ground conductor. Contact the appropriate electrical inspection authority or an electrician if you are uncertain that suitable grounding is available. Statement 1024

Step 2

Plug the AC power cord into the AC power input connector at the rear of the appliance. (See location 11 in [Figure 3-8](#).)

Step 3

Connect the other end of the power cord to a power source at your site.

Step 4

If you are installing a second redundant AC power supply, repeat Steps 1 and 3 for the second power supply.

Step 5

After confirming that all installation steps are complete, continue with the installation of the network and console cables. (See [“Connecting Appliance Cables” section on page 3-11](#).)



Caution

Do not power on the unit, yet.

Proceed to the next section, [“Grounding the Rack,”](#) to continue the installation.

Grounding the Rack

To avoid the potential for an electrical shock, you must include a third wire safety ground conductor with the rack installation. If the appliance power cord is plugged into an AC outlet that is part of the rack, then you must provide proper grounding for the rack itself. If the appliance power cord is plugged into a wall outlet, the safety ground conductor in the power cord provides proper grounding only for the appliance. You must provide additional, proper grounding for the rack.

Connecting Appliance Cables

This section describes how to connect cables to your Cisco NAM 2220 appliance for connections to a management port, a console terminal, and the monitoring ports. This section also provides suggestions about how to maintain the cabling for appearance and reliability.

This section includes the following topics:

- [Connecting the Management Port, page 3-12](#)
- [Connecting a Console Terminal, page 3-12](#)
- [Connecting the Monitoring Ports, page 3-13](#)
- [Cable Management, page 3-15](#)

Figure 3-8 shows the locations of the Cisco NAM 2220 appliance back panel connectors.

Figure 3-8 Cisco NAM 2220 Appliance Back Panel

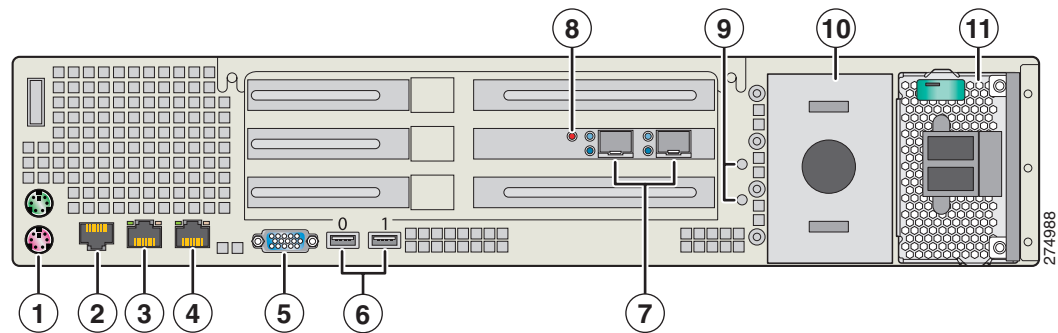

1	PS/2 connectors for keyboard and mouse (Used only for maintenance.)	7	Monitor port XFP transceiver slots <ul style="list-style-type: none"> • Slot on right provides input to logical DataPort 1 • Slot on left provides input to logical DataPort 2.
2	RJ-45 serial (console) port	8	GPS time sync signal connector
3	NAM Management port; NIC 1 (10/100/1000 Mb/s)	9	Ground studs
4	Non-functional NIC port Note This port is covered with a plastic connector.	10	Power supply 2 location (optional redundant power supply) If a second power supply is not used, a baffle covers this space (as shown).
5	Video (VGA) connector (Used only for maintenance.)	11	Power supply 1 (AC shown)
6	Unused USB ports (0 and 1)		

Connecting the Management Port



Warning

Do not work on the system or connect or disconnect cables during periods of lightning activity.

Statement 1001

The Cisco NAM 2220 appliance management port is the NIC 1 port, shown in location #3 in [Figure 3-8](#), an RJ-45 10BASE-T/100BASE-TX/1000BASE-T network interface connector.

To connect the Cisco NAM 2220 appliance management port, connect one end of a Cat5E UTP cable to the NIC 1 port on the appliance. Connect the other end of the cable to a hub or switch (a gateway) in your network.

The NIC 1 port supports standard straight-through Category 5E unshielded twisted-pair (UTP) cables. Your appliance shipped with one Category 5E UTP cable (yellow). If more UTP cables are needed, these cables are available commercially. (See [Table 1-5 on page 1-9](#) for information about Category 3, 4, 5, 5E, and 6 cables.)

Connecting a Console Terminal



Warning

Do not work on the system or connect or disconnect cables during periods of lightning activity.

Statement 1001

The Cisco NAM 2220 appliance console port is shown in location #2 on [Figure 3-8](#), an RJ-45 serial (console) connector. You can connect a console terminal using a PC running terminal-emulation software to the console port on the Cisco NAM 2220 appliance in either of two ways:

- Connect the terminal using a rollover cable to the appliance console port.
The rollover cable is provided in the cables shipped with your appliance. For cable pinouts, see the [“Serial \(Console\) Port Connector” section on page 1-10](#).
- Connect a terminal server to the appliance console port.

Configure your terminal or terminal-emulation software as shown in [Table 3-2](#).

Table 3-2 Terminal Configuration

Baud rate	9600
Data bits	8
Parity	No
Stop bit	1
Hardware flow control	Off

Connecting the Monitoring Ports

The Cisco NAM 2220 appliance monitoring ports are shown in location #7 on [Figure 3-8, Cisco NAM 2220 Appliance Back Panel](#). Each monitoring port supports a 10 GB long range (LR) or short range (SR) XFP transceiver module.

You can connect the Cisco NAM 2220 appliance directly to a device to monitor, such as a switch or router, or you can connect the appliance between two devices using an optical tap device.

Direct Connection

You connect the Cisco NAM 2220 appliance directly to a switch or router by running a fiber optical cable from a 10 GB Ethernet port on the remote device to an XFP transceiver module in the back panel of the Cisco NAM 2220 appliance.

**Note**

The Cisco NAM 2220 appliance supports both long range (LR) and short range (SR) 10 GB optical connections. Ensure that the 10 GB port on the switch or router port is the same type as its XFP transceiver module in the appliance.

The XFP slot on the right provides input to logical DataPort 1 and the slot on the left provides input to logical DataPort 2 of the Cisco NAM 2220 appliance.

Optical Tap Connection

You can connect the Cisco NAM 2220 appliance between two remote devices using an optical tap device. The optical tap mirrors the transmit sides of the cable that connects two remote devices as shown in [Figure 3-9](#).

**Note**

The optical tap connection requires two additional fiber optical cables.

Figure 3-9 Optical Tap Connection

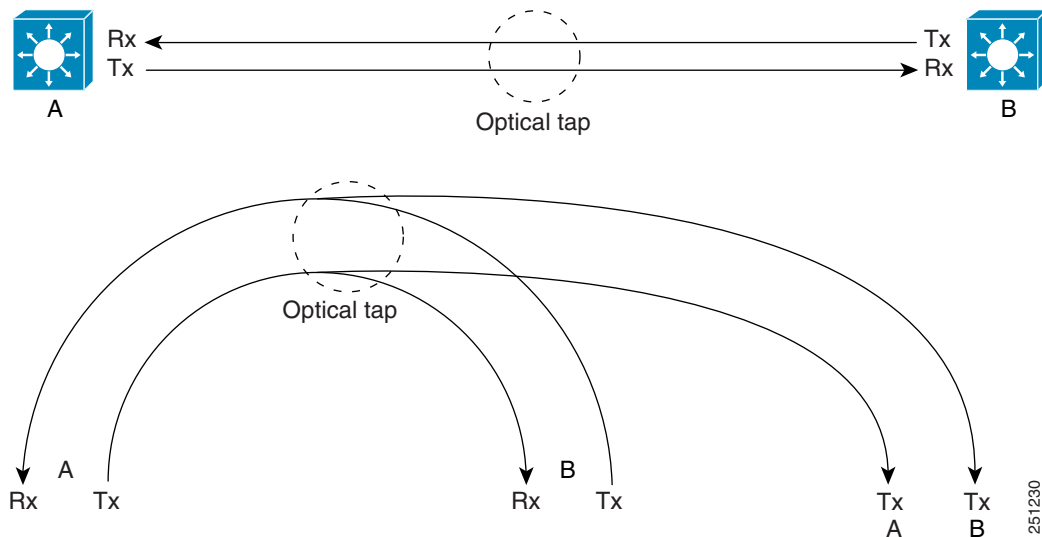
**Note**

You can find optical tap and cable specifications in [Appendix B, “Monitor Port Requirements.”](#)

To use an optical tap to connect the Tx signals of two devices to the Cisco NAM 2220 appliance monitoring ports:

- Step 1** Disconnect the 10 GE fiber optical cable that connects the two devices and plug the disconnected end of the cable into the appropriate ports on the optical tap for Device A.
- Step 2** Plug another 10 GE fiber optical cable into the output port for Device B, then plug the other end into the appropriate ports on the optical tap for Device B.
- Step 3** Run a third 10 GE fiber optical cable from the Tx A/Tx B ports on the optical tap device to the Cisco NAM 2220 appliance.
- Step 4** At the Cisco NAM 2220 appliance, separate the connectors at the end of the 10 GE fiber optical cable. The two connectors of the 10 GE fiber optical cable plug into different XFPs enabling the appliance to monitor all traffic between the two devices. See [Figure 3-9](#) for an illustration of the fiber optical cable inputs to the XFPs for an optical tap configuration.

Figure 3-10 Fiber Optical Cable Inputs for Optical Tap Configuration

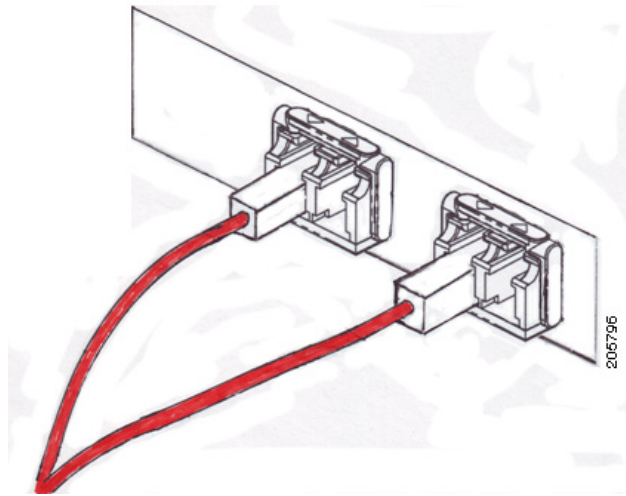

- Step 5** Plug Device A's Tx connector into the left side of the XFP on the right (logical DataPort1).
- Step 6** Plug Device B's Tx connector into the left side of the XFP on the left (logical DataPort2).

Cable Management

Cable management is the most visual aspect of your appliance setup. However, cable management is often overlooked because it can be time consuming.

Equipment racks and enclosures house more equipment today than ever before. This growth has increased the need for organized cable management both inside and outside the rack. Poor cable management not only leads to damaged cables or increased time for adding or changing out cables, but also blocks critical airflow or access. These problems can lead to inefficiencies in the performance of your equipment or even downtime.

There are many solutions to address cable management. They can range from simple cable management rings, to cable management brackets, to vertical or horizontal organizers, to troughs and ladders.

All Cisco NAM 2220 appliance cables should be properly dressed so as not to interfere with each other or other pieces of equipment. Use local practices to ensure that the cables attached to your appliance are properly dressed.

Proceed to the next section, "[Powering Up the Cisco NAM 2220 Appliance](#)," to continue the installation.

Powering Up the Cisco NAM 2220 Appliance



Warning

Do not touch the power supply when the power cord is connected. For systems with a power switch, line voltages are present within the power supply even when the power switch is off and the power cord is connected. For systems without a power switch, line voltages are present within the power supply when the power cord is connected. Statement 4



Warning

This equipment is intended to be grounded. Ensure that the host is connected to earth ground during normal use. Statement 39

See [Power-Up Procedure, page 3-16](#), for information about how to power up the appliance.

Power-Up Procedure

To power up a Cisco NAM 2220 appliance and verify its initialization and self-test, follow this procedure. When the procedure is finished, the appliance is ready to configure.

-
- Step 1** Review the information in the [“Safety Guidelines” section on page 2-2](#).
 - Step 2** Before proceeding, if the AC power cord is connected directly into the AC power outlet and because the AC power cord provides its own ground conductor, you only need to ensure that the rack has been properly grounded. (See the [“Connecting the Appliance AC Power” section on page 3-10](#) for more information.)
 - Step 3** Plug the AC power cord into the power cord receptacle at the rear of the appliance. (See location 11 in [Figure 3-8](#).)
 - Step 4** Connect the other end of the power cord to a power source at your installation site.
 - Step 5** If there is a second AC power supply, repeat Steps 3 and 4 for the second power supply.
 - Step 6** Press the power button on the front of the appliance. (See location 9 in [Figure 1-3, Cisco NAM 2220 Appliance Front Control Panel](#).)

The appliance should begin its power-up procedure.

- Step 7** After the operating system boots up, observe the front-panel LEDs to verify that your system is operating properly. (See [Figure 3-11 on page 3-17](#) and the [“Checking the LEDs” section on page 3-17](#).)
- After the operating system boots, you are ready to initialize the basic software configuration. (See the software installation guide or user guide that shipped with your appliance for proper configuration procedures.)
-

Checking the LEDs

When the Cisco NAM 2220 appliance is up and running, observe the front-panel LEDs as shown in [Figure 3-11](#).

Figure 3-11 Cisco NAM 2220 Appliance Front Control Panel

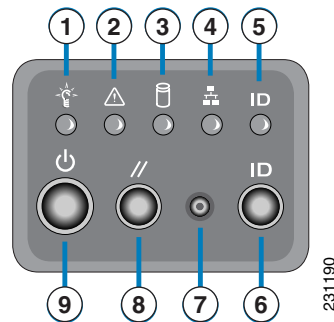

1	Appliance power LED	6	ID control switch (push button)
2	Appliance status LED	7	Unused non-maskable interrupt
3	Hard disk drive activity LED	8	Reset push button
4	NIC activity (all NICs)	9	Appliance power push button
5	Appliance system ID LED		

The following LEDs provide power, activity, and status information:

Cisco NAM 2220 Appliance Front-Panel LEDs

- Appliance power, green:
 - On when power is on.
 - Off when power is off or an error condition has been detected in the operating voltages.
- Hard disk activity, green:
 - On when appliance software has booted up, and the appliance is operational.
 - Off when appliance has not yet booted, or an error condition has been detected in the boot process.
- NIC 1 green:
 - On when packets are transferring
 - Off when no packets are transferring

For more detailed information about the LEDs, see [Appendix C, “Troubleshooting.”](#)

Removing or Replacing the Cisco NAM 2220 Appliance

Always use the NAM CLI command **shutdown** to shut down the NAM application when you turn power off.



Warning

Before working on a system that has an On/Off switch, turn OFF the power and unplug the power cord.
Statement 1



Warning

Ultimate disposal of this product should be handled according to all national laws and regulations.
Statement 1040

To remove a Cisco NAM 2220 appliance from your network, power it down, disconnect the power cords and network cables, and physically remove the appliance from the rack.

The appliance is in constant communication on your network; thus, when the network notices that the appliance is no longer responding to it, the network stops sending requests to the appliance. This change is transparent to users. If other appliances are attached to the network, the network continues sending requests to the other appliances.

To replace an appliance, remove it from the network. Then, install a new appliance and configure it using the same configuration parameters that you used for the removed appliance.