



Prepare for Installation

Before you install the Cisco NCS 540, you must prepare your site for the installation.

Preparing your site involves these tasks:

- [General Precautions, on page 1](#)
- [Site Planning Checklist, on page 2](#)
- [Environmental Requirements, on page 2](#)
- [Airflow Guidelines, on page 2](#)
- [Site Power Guidelines, on page 5](#)
- [Site Cabling Guidelines, on page 7](#)
- [Tools and Equipment, on page 7](#)
- [Prepare Your Location , on page 8](#)
- [Prepare Yourself , on page 9](#)
- [Prepare Rack for Router Installation, on page 10](#)
- [Cabinet Selection Guidelines, on page 10](#)
- [Unpack the Cisco NCS 540 Router, on page 11](#)

General Precautions

Observe the following general precautions when using and working with your chassis:

- Keep your system components away from radiators and heat sources, and do not block cooling vents.
- Do not spill food or liquids on your system components, and never operate the product in a wet environment.
- Do not push any objects into the openings of your system components. Doing so can cause fire or electric shock by shorting out interior components.
- Position system cables and power supply cable carefully. Route system cables and the power supply cable and plug so that they are not stepped on or tripped over. Ensure that nothing is resting on your system component cables or power cable.
- Do not modify power cables or plugs. Consult a licensed electrician or your power company for site modifications. Always follow your local and national wiring rules.
- If you turn off your system to avoid damage to the system components, wait at least 30 seconds before turning it on again.

Site Planning Checklist

Use the following checklist to carry out all site planning tasks:

- The site meets environmental requirements.
- The site's air conditioning system can compensate for the heat dissipation of the chassis.
- The floor space that the chassis occupies can support the weight of the system.
- Electrical service to the site complies with the safety with electricity requirements.
- The electrical circuit servicing the chassis complies with the power supply requirements.
- Console port wiring and cabling limitations have been considered in accordance to TIA/EIA-232F.
- The chassis Ethernet cabling distances are within prescribed limits.
- The equipment rack where the chassis is to be installed complies with prescribed requirements.
- The following factors have been carefully considered when selecting rack: location, safety, ease of maintenance, and proper airflow.

Environmental Requirements



Note The outside plant installation is not supported on Cisco N540-28Z4C-SYS-A/D, and N540-12Z20G-SYS-A/D routers.

For outside plant installation (cell site cabinet, hut, and so on), you must protect the router against airborne contaminants, dust, moisture, insects, pests, corrosive gases, polluted air, or other reactive elements. Sealed equipment chamber with air-conditioning or a heat exchanger is recommended for OSP deployments. The equipment chamber must comply with the temperature and clearance requirements. To achieve this level of protection, we recommend that the unit be installed in a fully sealed enclosure or cabinet. Examples of such cabinets include IP65 cabinets with heat exchanger complying with Telcordia GR487. Temperature must be maintained within -40°C to 70°C .

For more information on Environmental properties and Regulatory standards, see the [Cisco Network Convergence System 540 Router Data Sheet](#).

Airflow Guidelines

Cool air is circulated through the router by fans that are located along the back side of the router. The internal fans maintain acceptable operating temperatures for the internal components by drawing in cool air through the vents, and circulating the air through the router.

To ensure adequate airflow, it is recommended that you maintain a minimum clearance distance always, as mentioned in the following figure.

- Front clearance—5 inches (12.7 centimeters)

- Rear clearance—2 inches (5.08 centimeters)

Figure 1: Top View of Clearance

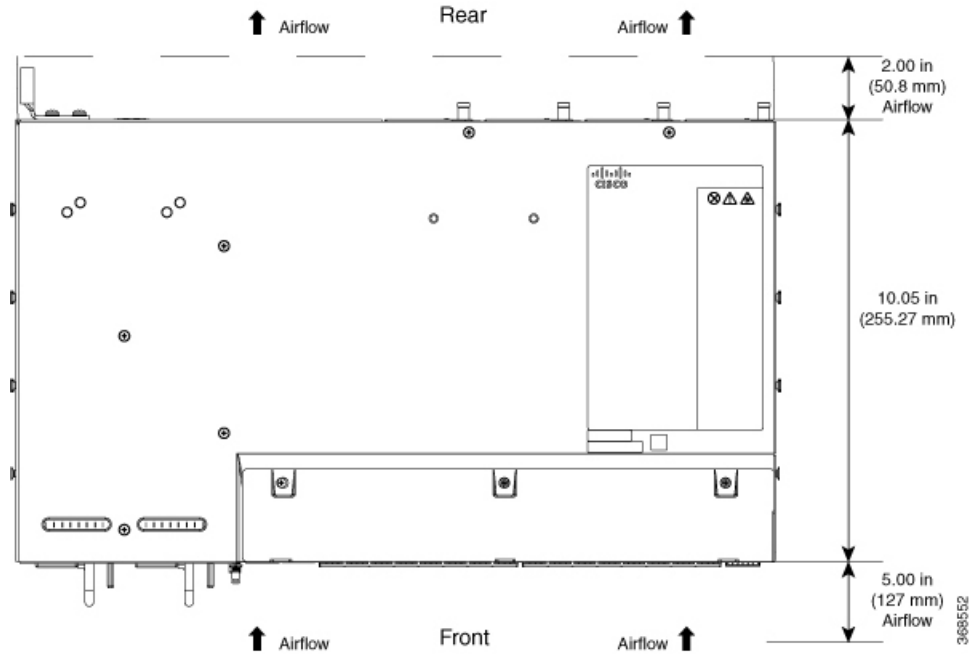

Figure 2: Side View of Clearance

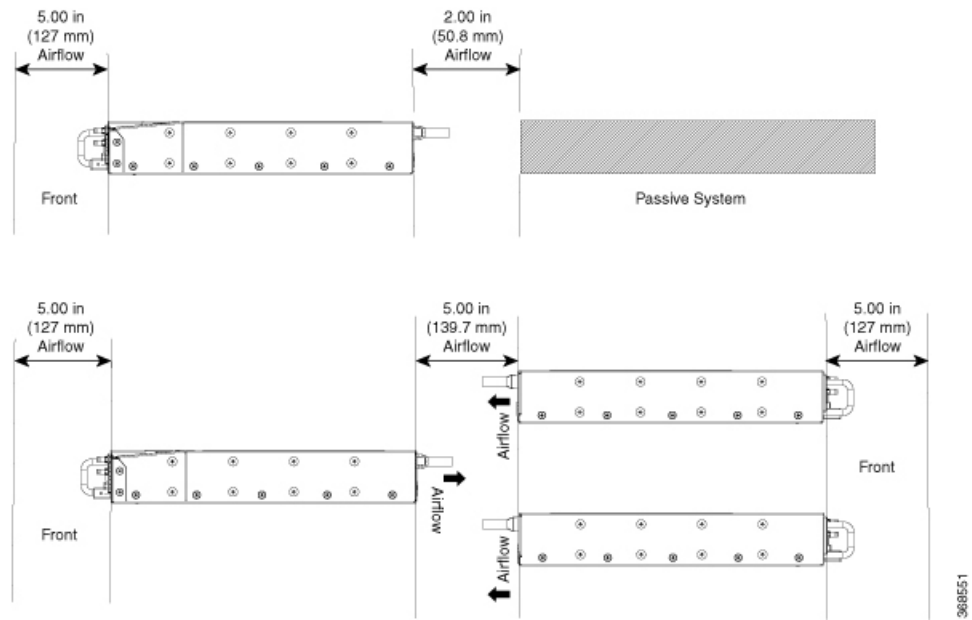

Figure 3: Airflow Side View

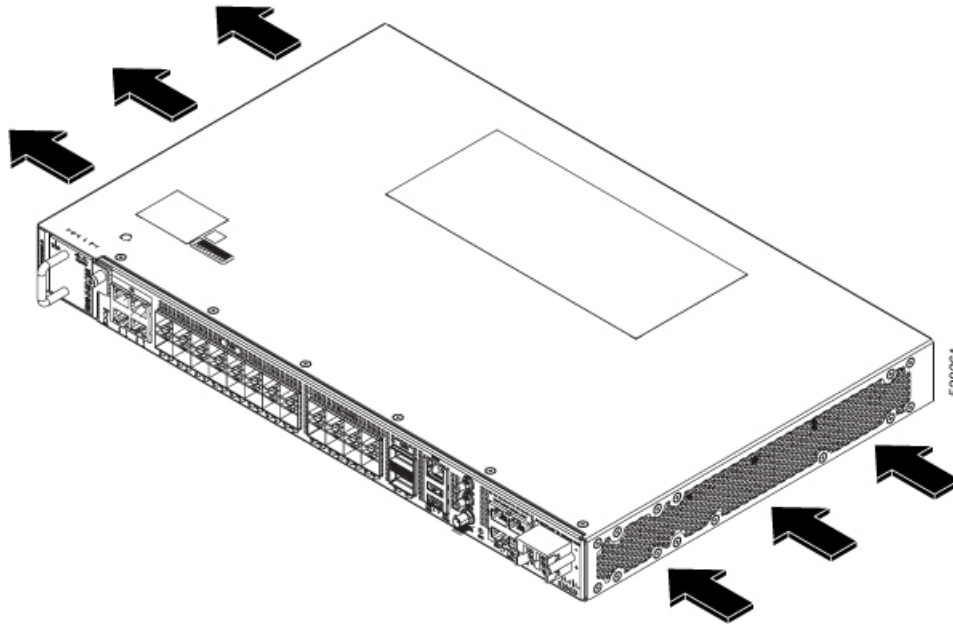

Table 1: Airflow Guidelines

Router	Flow Direction	Air Clearance
N540X-16Z4G8Q2C-A N540X-16Z4G8Q2C-D N540X-12Z16G-SYS-A N540X-12Z16G-SYS-D N540X-16Z8Q2C-D	Right to Left	At least 3 inches (7.62 centimeters) required on both inlet and exit directions.

Note the following points:

- When installing the router in a back-to-back position with another device, ensure that there is a minimum of 3.9 inches (10 centimeters) airflow clearance between the two devices.
- If airflow through the equipment rack and the routers that occupy it is blocked or restricted, or if the ambient air being drawn into the rack is too warm, an overtemperature condition may occur within the rack and the routers that occupy it.
- The site must be as dust-free as possible. Dust tends to clog the router fans, reducing the flow of cooling air through the equipment rack and the routers that occupy it, thus increasing the risk of an overtemperature condition.
- Enclosed racks must have adequate ventilation. Ensure that the rack is not congested because each router generates heat. An enclosed rack must have louvered sides and a fan to provide cooling air. The equipment generates heat near the bottom of the rack, which can be drawn upward into the intake ports of the equipment above.

- When mounting a router in an open rack, ensure that the rack frame does not block the exhaust fans.
- When rack-installed equipment fails, especially equipment in an enclosed rack, try operating the equipment by itself, if possible. Power off all the other equipment in the rack (and in adjacent racks) to give the router maximum cooling air and clean power.
- Avoid installing the router in a location in which the router air intake vents may draw in the exhaust air from adjacent equipment. Consider how the air flows through the router; the airflow direction is front to back, with ambient air drawn in from the vents located on the sides of the router.

Site Power Guidelines

The chassis has specific power and electrical wiring requirements. Adhering to these requirements ensures reliable operation of the system. Follow these precautions and recommendations when planning your site power for the chassis:

- The redundant power option provides a second, identical power supply to ensure uninterrupted power supply.
- Connect each power supply to a separate input power source. Otherwise, it results in total power failure to the system due to a fault in the external wiring or a tripped circuit breaker.
- To prevent loss of input power, ensure that the maximum load on each circuit is within the current ratings of the wiring and the breakers.
- Check the power at your site before installation, and periodically after installation, to ensure that you're receiving clean power. If necessary, install a power conditioner.
- Provide proper grounding to avoid personal injury and damage to the equipment due to power surges or lightning striking power lines. The chassis ground must be attached to a central office or other interior ground system.



Note

The chassis installation must comply with all the applicable codes, and is approved for use with only copper conductors. The ground bond-fastening hardware must be compatible and preclude loosening, deterioration, and electrochemical corrosion of hardware and joined material. Attachment of the chassis ground to a central office or other interior ground system must be made with a 6-AWG gauge wire copper ground conductor.



Caution

This product requires an external surge protection device for both AC and DC power feeds to the equipment. For a DC power feed, the surge protective device (SPD) must handle common mode and differential mode surge as per the local standards.



Caution The AC PSU requires external surge protection devices (SPD) for installations, where an electrical surge is higher than 2KV common mode and higher than 2KV differential mode. Failure to do so may result in permanent damage to the router. Following are the applicable router variants:

- N540-24Z8Q2C-SYS
- N540X-ACC-SYS
- N540-ACC-SYS
- N540X-16Z4G8Q2C-A
- N540X-12Z16G-SYS-A
- N540-28Z4C-SYS-A
- N540X-16Z8Q2C-A
- N540-12Z20G-SYS-A



Caution The DC PSU requires external surge protection devices (SPD) for installations, where an electrical surge is higher than 2KV common mode and higher than 1KV differential mode. Failure to do so may result in permanent damage to the product. Following are the applicable router variants:

- N540-24Z8Q2C-SYS
- N540X-ACC-SYS
- N540-ACC-SYS
- N540X-16Z4G8Q2C-D
- N540X-12Z16G-SYS-D
- N540X-16Z8Q2C-D

Following are the applicable router variants that require external surge protection devices (SPD), where an electrical surge is higher than 1KV common mode and higher than 1KV differential mode:

- N540-12Z20G-SYS-D
 - N540-28Z4C-SYS-D
-

Electrical Circuit Requirements

Each chassis requires a dedicated electrical circuit. If you equip the device with dual-power feeds, provide a separate circuit for each power supply to avoid compromising the power redundancy feature.

The chassis supports both DC source or an AC source. Ensure that equipment grounding is present and observe power-strip ratings. Make sure that the total ampere rating of all the products plugged into the power strip does not exceed 80% of the rating.

Site Cabling Guidelines

This section contains guidelines for wiring and cabling at your site. When preparing your site for network connections to the router, consider the type of cable required for each component, and the cable limitations. Consider the distance limitations for signaling, ElectroMagnetic Interference (EMI), and connector compatibility. Possible cable types are fiber, thick or thin coaxial, foil twisted-pair, or unshielded twisted-pair cabling.

Also consider any additional interface equipment you need, such as transceivers, hubs, switches, modems, Channel Service Units (CSU), or Data Service Units (DSU).

Before you install the router, have all the additional external equipment and cables on hand. For information about ordering, contact a Cisco customer service representative.

The extent of your network and the distances between the network interface connections depend, in part, on the following factors:

- Signal type
- Signal speed
- Transmission medium

The distance and rate limits referenced in the following sections are the IEEE-recommended maximum speeds and distances for signaling purposes. Use this information as a guideline when planning your network connections *prior to* installing the router.

If wires exceed the recommended distances, or if wires pass between buildings, give special consideration to the effect of a lightning strike in your vicinity. The electromagnetic pulse caused by lightning or other high-energy phenomena can easily couple enough energy into unshielded conductors to destroy electronic devices. If you have had problems of this sort in the past, you may want to consult experts in electrical surge suppression and shielding.

Asynchronous Terminal Connections

The router provides a console port to connect a terminal or computer for local console access. The router supports RS-232 asynchronous data with distance recommendations specified in the IEEE RS-232 standard.

Interference Considerations

When wires are run for any significant distance, there is a risk that stray signals will be induced on the wires as interference. If interference signals are strong, they may cause data errors or damage to the equipment.

The following sections describe the sources of interference and how to minimize their effects on the router system.

Tools and Equipment

You need the following tools and equipment to install and upgrade the device and its components:

- ESD-preventive cord and wrist strap

- Antistatic mat or antistatic foam
- Number 1 and Number 2 Phillips-head screwdrivers
- #12-24 pan-head screws to secure the device to the equipment rack
- Cables for connecting to network ports (based on the configuration)
- Ethernet hub, switch, or PC with a network interface card for connecting to the Ethernet ports
- Console terminal that is configured for 115200 baud, 8 data bits, no parity, no flow control, and 2 stop bits
- Console cable for connecting to the console port
- Ratcheting torque screwdriver with a Phillips head that exerts up to 30-pound force per square inch (0.02-kilograms force per square millimeter (kgf/mm²)) of pressure
- Crimping tool as specified by the ground lug manufacturer
- Wire-stripping tools for stripping both 6 and 14-AWG wires
- Tape measure and level
- Ratcheting torque screwdriver with a Phillips head that exerts up to 15 inch-pounds (1.69 newton meters) of torque for attaching the ground wire to the device

Prepare Your Location

This section illustrates how the building that houses the chassis must be properly grounded to the earth ground.

Figure 4: Building with Rack Room Connected to Earth Ground

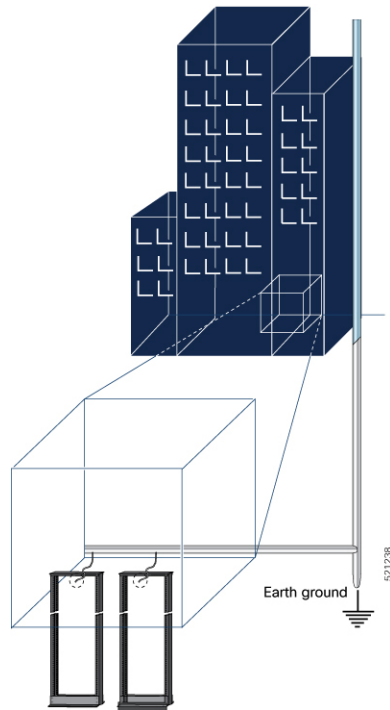

Prepare Yourself

This section illustrates how to prepare yourself before removing the chassis from the sealed antistatic bag. The figures show how to wear the ESD strap around the wrist and how to connect the other end of the strap to the ground. ESD wrist straps are the primary means of controlling static charge on personnel.

Note: These images are for only representation purposes. The chassis' actual appearance and size would vary.

Figure 5: Wearing the ESD Strap

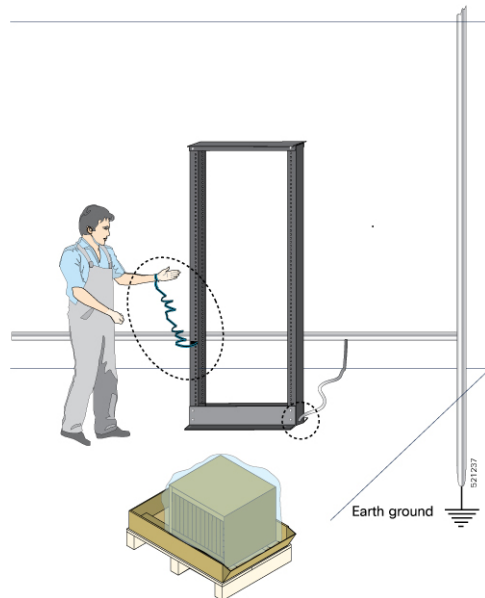

Prepare Rack for Router Installation

Install the chassis into a two-post standard rack with standard horizontal mounting rails. Before you mount the chassis into the rack, we recommend that you do the following:

Step 1 Place the rack where you plan to install the chassis. Ensure that the rack is grounded to earth.

Step 2 Secure the rack to the floor.

To bolt the rack to the floor, a floor bolt kit (also called an anchor embedment kit) is required. For information on bolting the rack to the floor, consult a company that specializes in floor mounting kits (such as Hilti; see [Hilti.com](https://www.hilti.com) for details). Make sure that floor mounting bolts are accessible, especially if an annual retorquing of bolts is required.

Cabinet Selection Guidelines

Equipment that is intended for installation in controlled environmental space has average yearly levels of contamination. Ventilated cabinets or racks can be used if pollutant levels are maintained within allowable limits.

Equipment intended for installation in outside plant (OSP) areas must have sealed cabinets with heat exchanger that meet the IP65 or IP66 protection and low average yearly levels of concentration of contaminants inside the cabinet.



Note Ventilated cabinets and racks are not recommended for OSP applications.

Table 2: Cabinet Type for Indoor and Outdoor Installation

Cabinet Type	Suitable for Indoor Installation?	Suitable for Outdoor Installation?
Open rack with no front and rear doors	Yes	No
Ventilated cabinets with normal air filter at intake and fans	Yes	No
Sealed cabinets with heat exchanger that meet NEMA -4 or IP66 protection	Yes	Yes
Sealed cabinets with air-conditioners that meet NEMA -4 or IP66/IP65 protection	Yes	Yes

Allowable limits for Environmental Pollutants

Concentration of pollutant levels in outdoor and indoor environment must be less than pollutant levels mentioned in Table 2.3 and Table 2.4 of *NEBS GR-63-CORE Issue 5 Dec 2017*, respectively. High concentrations of pollutants have a negative impact on the equipment life time.

Allowable Temperature and Humidity

Maximum allowable temperature and humidity levels must be within the values that are mentioned in the data sheets. Do not install in places where condensation may occur, or where equipment is exposed to high humidity for long time, such as near the sea, rivers, and large water bodies.

Installations in Highly-corrosive Environment

Installation in highly corrosive area is not recommended. Examples of highly corrosive areas are seashore, less than 10 meters from high traffics roadway, and areas having high industrial pollutants.

Periodic Measurement of Environmental Pollutants

We recommend that you check concentration of pollutants periodically. Necessary protection should be provided to ensure the equipment is not exposed to high concentration level of pollutants.

Unpack the Cisco NCS 540 Router

Before you begin

Ensure that there is sufficient room around the chassis pallet for unpacking.

-
- Step 1** Remove the accessory tray and the packing material.
- Step 2** Carefully set the packing material aside.

Tip Be sure to save the packaging in case you need to return any of the components products.

Note These images are for only representation purposes. The chassis' actual appearance and size would vary.

Figure 6: Unpacking the Device

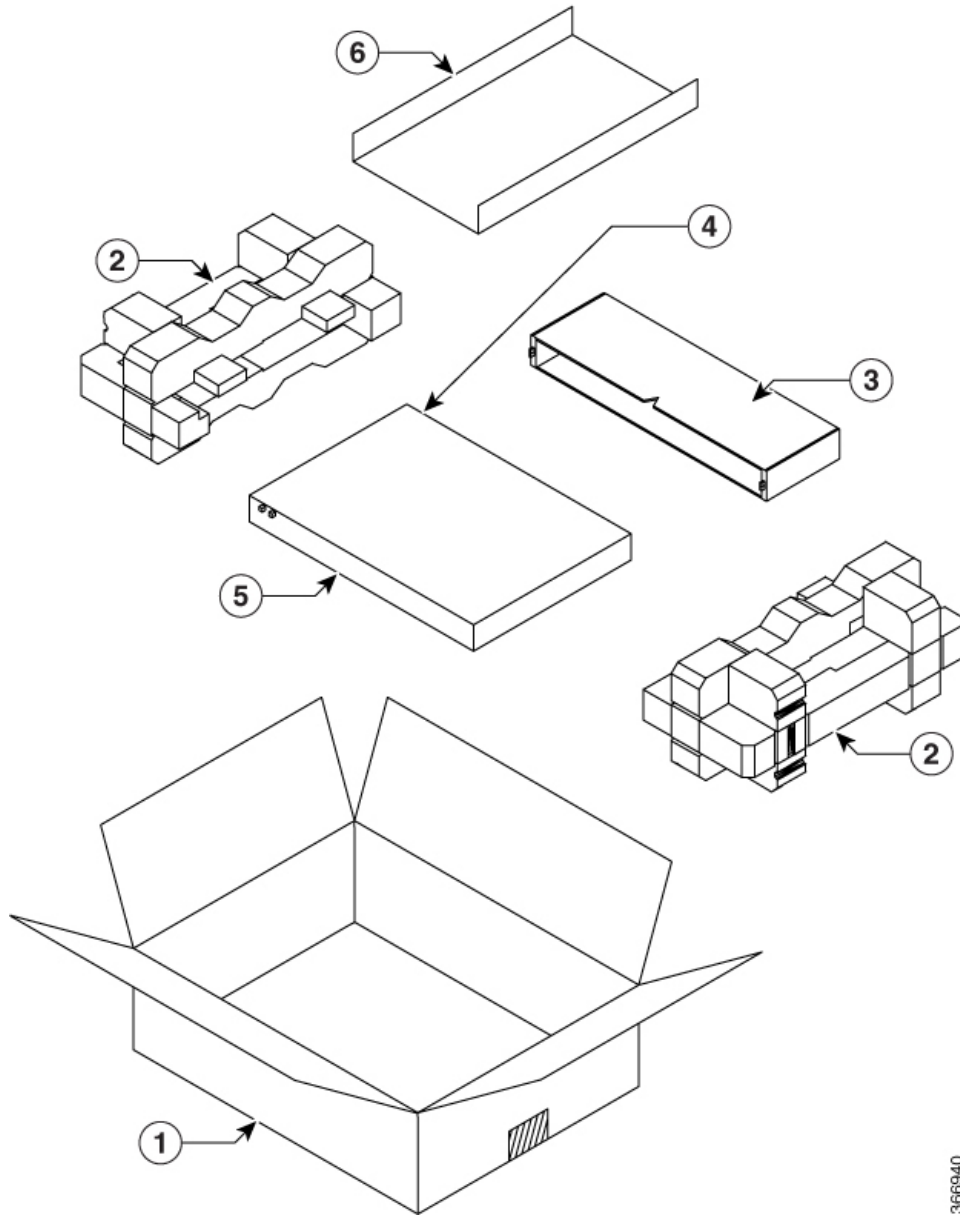

366940

1	Regular Slotted Container (shipping box)	2	Foam end caps
3	Front corrugated cap	4	Front end of the product
5	Back end of the product	6	Accessory tray

What to do next

Table 3: Accessories Kit

Category	N540-28Z4C-SYS-A/D	N540-12Z20G-SYS-A/D	N540X-16Z802C-A/D	N540X-16Z802C-D	N540X-12Z16G-SYS-A/D
19-inch rack mount brackets	N540RCKMT-19-CLA / N540RCKMT-19-CLD	N540RCKMT-19-CLA / N540RCKMT-19-CLD	N540RCKMT-19-EGA / N540RCKMT-19-EGD	N540RCKMT-19-EGA / N540RCKMT-19-EGD	N540-RCKMT-19-ACA / N540-RCKMT-19-ACD
23-inch rack mount brackets	N540RCKMT-23-CLA / N540RCKMT-23-CLD	N540RCKMT-23-CLA / N540RCKMT-23-CLD	N540RCKMT-23-EGA / N540RCKMT-23-EGD	N540RCKMT-23-EGA / N540RCKMT-23-EGD	N540-RCKMT-23-ACA / N540-RCKMT-23-ACD
ETSI rack mount brackets	N540RCKMT-EIS-CLA / N540RCKMT-EIS-CLD	N540RCKMT-EIS-CLA / N540RCKMT-EIS-CLD	N540RCKMT-EIS-EGA / N540RCKMT-EIS-EGD	N540RCKMT-EIS-EGA / N540RCKMT-EIS-EGD	N540RCKMT-EIS-ACA / N540RCKMT-EIS-ACD
Wall mount brackets	N540-WALLMT-CLA	N540-WALLMT-CLA	Not supported	Not supported	Not supported
Cable management brackets	N540-CBL-BRKT-CL	N540-CBL-BRKT-DN	N540-CBL-BRKT-EG	N540-CBL-BRKT-EG	N540-CBL-BRKT-AC



Note Most Cisco documentation is available online. The chassis Pointer Card that is shipped with your Cisco NCS 500 Series Services Routers contains links and information to other online documentation.



Note If the product is not in use, store the device in the initial packaged condition or in an ESD PE sealed bag with silica gel.

The following accessories kit is applicable to the Cisco N540-24Z8Q2C-SYS, N540X-ACC-SYS, and N540-ACC-SYS variants.

Table 4: Accessories Kit

Category	Model
Cable management brackets	N540-CBL-GD-19 N540-CBL-GD
19-inch rack mount brackets	N540-RCKMT-19
23-inch rack mount brackets	N540-RCKMT-23

Category	Model
ETSI rack mount brackets	N540-RCKMT-ETSI