



# Configure Egress Traffic Management

This chapter covers the following topics:

- [Egress Traffic Management, on page 1](#)
- [More About the Egress Traffic Management Model, on page 4](#)
- [QoS Policy Configuration Rules, on page 6](#)
- [Configure Egress Traffic Management , on page 6](#)
- [Low Rate Shaper, on page 22](#)
- [Low Rate Shaper for Enhanced Granularity, on page 25](#)

## Egress Traffic Management

*Table 1: Feature History Table*

| Feature Name   | Release Information | Feature Description  |
|--|---------------------|--|
| Egress Traffic Management on NCS-57C3 Fixed Port Routers | Release 24.1.1      | <p>Introduced in this release on: NCS 5700 fixed port routers (select variants only*)</p> <p>This model enhances the egress queueing policy by making the feature-rich ingress pipeline available to the outgoing traffic. It also enables the scaling of egress QoS policies by limiting the usage of VOQ connectors on all ingress devices to only physical ports or main interfaces.</p> <p>*This feature is supported on NCS-57C3-MOD-SYS routers.</p> |

| Feature Name              | Release Information | Feature Description   |
|---------------------------|---------------------|---|
| Egress Traffic Management | Release 7.6.1       | <p>The egress traffic management model employs a two-pass model per NPU core to get up to 50% of NPU core bandwidth as recycle bandwidth. VOQ lookup takes place in the second pass to get the outgoing interface or sub-interface VOQ. This lookup at the second pass enhances the egress queuing policy by making the feature-rich ingress pipeline available to the outgoing traffic.</p> <p>Also, this functionality is configurable at the port level and not at the global level. This approach limits the usage of VOQ connectors required on all ingress devices to only physical ports or main interfaces, thus enabling scaling of egress QoS policies.</p> <p>This functionality introduces the <b>mode etm</b> option for the <b>controller optics</b> command.</p> |

The egress traffic management model modifies the existing [Ingress Traffic Management Model](#) to ensure you can configure higher QoS scales. It does so by using a recycle model at egress NPU so that the packet buffering takes place at egress NPU. (See figure, **The Egress Traffic Management Model**.) Also, egress traffic management is configurable at the port-level and not at the global level, to maximize flexibility.

Figure 1: The Egress Traffic Management Model

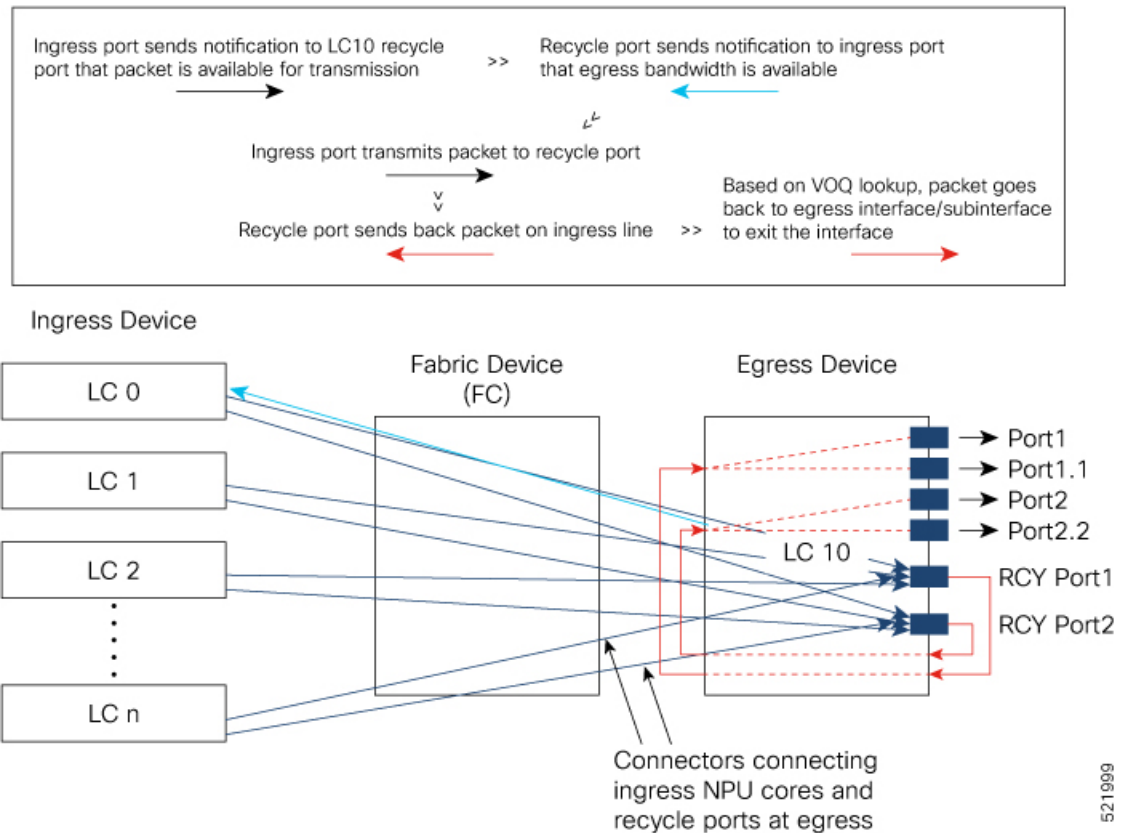

In the figure, every ingress NPU port (LC 0 through LC n) has eight VOQs for the single egress NPU LC 10.

Here’s how packet transmission takes place:

1. When a packet arrives at ingress port (say on LC 0), the forwarding lookup on ingress line card points to the egress interface that could be physical, subinterface, Link aggregation Group (LAG), or LAG subinterface. In the case of LAG, hashing takes place at the ingress line card to select the LAG member from where the packet will be sent out. Based on the egress interface (say it is on LC10), the packet is enqueued to the VOQ of LC 10. The egress interface is always mapped to a physical port.
2. However, unlike in the ingress traffic management model where the ingress NPU ports connect to the egress NPU ports (per traffic management hierarchy), the egress traffic management model connects ingress NPU ports to the recycle port that's mapped to the egress port.
3. Once egress bandwidth is available, the recycle ports (based on the packet marking and distribution model) send grants to the ingress ports via the connectors. (The figure shows a separate line for the grant for the sake of visual representation. In reality, the same connector is used for requests, grants, and transmission between an NPU core at the ingress and the corresponding recycle port.)
4. The ingress NPU responds to this permission by transmitting the packet via the fabric device (FC) to the egress NPU.
5. Once the packet reaches egress NPU, it gets recycled back to the ingress pipeline of the egress NPU. A VOQ lookup takes place at this stage that checks if there’s a policy on the subinterface. If there’s no policy on the subinterface, the main interface VOQ is taken. This behavior is the same as in the ingress traffic

management model, except that another VOQ lookup for subinterface and the main interface takes place in the second pass (recycle) on the egress NPU core.

6. Based on the lookup in the second pass, the packets go back into the egress to the specified main interface or subinterface. It's also in the second pass that any queuing action kicks in before the packets go out the egress interface.

#### Hardware Limitation:

Even though the traffic rate at the VoQ level is less than that of the VoQ shaper, the router experiences unexpected traffic drops when more than 1000 VoQs (created by egress QoS policies) are holding packets due to active traffic flows and consume all the available on-chip buffers (OCBs).

## More About the Egress Traffic Management Model

### • Which routers and line cards support the egress traffic management model?

The egress traffic management model is supported on routers that have the following Cisco NC57 line cards that are installed and that operate in the native mode:

- NC57-18DD-SE
- NC57-36H-SE

This feature is also supported on the following Cisco NCS-57B1 chassis variants:

- NCS-57B1-5D24H-SE
- NCS-57B1-5DSE-SYS

From Release 24.1.1, this feature is also supported on the Cisco NCS-57C3 fixed port routers (NCS-57C3-MOD-SYS)

### • What benefits does the egress traffic management model offer?

- Configuring the egress traffic management functionality offers you **higher scales of egress QoS policies**. And this is because of the way the egress traffic management model is designed, reducing the size of the mesh of connectors to main and subinterface ingress ports.
- Plus, because of this model (where a second lookup and queuing action takes place in the recycled pass), the **egress queuing policy is enhanced**. An egress traffic management queuing policy contains the same match criteria that ingress policies typically contain. (See the following table for details.) In addition, match on traffic-class and remarking traffic-class is also supported in egress with the **hw-module profile qos ipv6 short-etm** command. (For details, see [Configure Egress Traffic Management](#), on page 6.) This means that the egress traffic management model offers you with even more flexibility in planning your egress policies, while supporting higher scale numbers.

| Flow Type | Egress Classification Type Supported  |
|-----------|---|
| IPv4/IPv6 | <ul style="list-style-type: none"> <li>• Prec / DSCP</li> <li>• SIP / DIP / SP / DP / Protocol / TCP-CTL via ACLs</li> <li>• COS / DEI (for VLAN)</li> <li>• Fragmentation</li> </ul> |
| MPLS      | <ul style="list-style-type: none"> <li>• IPv4 ToS / IPv6 TC (for underlying for IPv4/IPv6)</li> <li>• COS / DEI (for VLAN)</li> <li>• MPLS Exp</li> </ul>                             |
| Layer 2   | <ul style="list-style-type: none"> <li>• COS / DEI (for VLAN)</li> <li>• COS Inner / DEI Inner (for VLAN)</li> <li>• IPv4 ToS</li> <li>• IPv6 TC</li> <li>• MPLS Exp</li> </ul>       |

- There's another important benefit that the egress traffic management model offers. You need higher QoS scale and features only for access- or edge-facing interfaces, and not on core-facing interfaces. The egress traffic management model provides the **flexibility to configure recycle mode only on access facing ports** while continue using core facing ports in single-pass mode.
- Configuring the egress traffic management functionality enables the low rate shaper feature. For details, see [Low Rate Shaper](#), on page 22.

- **How many VOQs are there on the recycle port per egress interface when ETM is enabled?**—There are eight VOQs on the recycle port per egress interface or sub-interface when ETM is enabled.
- **What is the priority structure of these VOQs?**—VOQs 6-7 are designated as strict (high-priority), whereas VOQs 0-5 are treated as low priority.
- **How is the rate of each recycle port VOQ determined?**—Each recycle port VOQ has a rate equal to the egress port rate. Therefore, the available bandwidth between the recycle port and the egress interface is eight times the egress port rate.
- **What is the buffer size per recycle port VOQ?**—The buffer per recycle port VOQ is 10 ms of the egress port rate.
- **How is traffic assigned to the VOQs?**—Traffic is assigned to the VOQs based on traffic class markings. It is essential to set these markings using a policy on the ingress port.
- **In the recycle pass, packets are sent back on the ingress pipeline. What's the impact?**—The impact is **reduced throughput**. Recycle traffic competes with ingress traffic on the ingress pipeline; this impacts

the traffic throughput. Thus, higher scales come at the cost of reduced throughputs. In such contention cases, device throughput drops down to 50%.

- **How do I handle Link Aggregation Group (LAG) configurations?**—All LAG members must have the same mode. This means that you must **configure the egress traffic management mode on all LAG members**.
- **Which MDB profiles are supported for the egress traffic management model?**—All SE-based MDB profiles are supported for the egress traffic management model. (SE-based MDB profiles are the scaled versions that allow for configuring more QoS policies on systems using eTCAM.)
- **Important Note on LOCP Statistics**—When you attach a policy map to a subinterface in the egress traffic management model, the Locally Originated Control Protocol (LOCP) packets exiting that subinterface are accounted for in the subinterface policy counters.

Without the egress traffic management model, egress inject LOCP packets are not accounted for in sub-interface egress policy counters.

## QoS Policy Configuration Rules

- The **set traffic-class** configuration for all traffic classes is mandatory at egress for egress traffic management ports, regardless of your ingress configuration. This **set traffic-class val** represents the VOQ offset that the matching packets select. The only exception to this rule is the class-default configuration.
- The class-default can have a **set traffic-class val** other than 0.
- Even if the ingress and egress traffic classes match, you'll still need to configure a **set traffic-class val** at egress. If the match and set values differ, then the traffic-class is remarked. For example, say a traffic-class is set to 1 in the ingress policy and the match on that traffic-class is 1 on the egress in the egress traffic management policy. Then, say, at the second pass, the **set traffic-class val** is remarked to 5. The packets that match this class in the egress traffic management policy go to VOQ offset 5.
- You can set traffic-class for multiple traffic classes to the same value. In such a situation, traffic matching those classes head to the same VOQ. Therefore, the statistics for all these classes point to the same VOQ counters. It's important to note that when multiple traffic classes have the same value in the **set traffic-class val** action, then the queuing parameters (for example, priority or bandwidth remaining, queue depth, WRED) of these classes **MUST** be the same.
- In a hierarchical policy, you can configure the **set traffic-class val** only for the child traffic classes. The parent classes can't have the **set traffic-class val** action.
- In egress packet recycle scenarios, ensure that the values configured using **set traffic-class** and **set qos-group** are identical in an egress policy-map.

## Configure Egress Traffic Management

### Before You Begin

Some critical points to note before you begin:

- Before you proceed any further, ensure that you delete your existing **hw-module profile qos hqos-enable** configuration and restart your system. Only then can you enable egress traffic management at the port level. H-QoS profiles and egress traffic management configurations can't coexist.
- The egress traffic management mode is configured on a per-port mode. This ensures that the core-facing ports continue using the current ingress-based VOQ model, while the access ports use the egress traffic management model. Such an approach reduces the consumption of the recycle bandwidth. See the following table for details.

*Table 2: Global H-QoS versus Per Port Configuration*

| Global H-QoS with hw-module profile qos hqos-enable |                         | Per Port Egress Traffic Management (ETM) without hw-module profile qos hqos-enable |                         |                         |                                |
|---|-------------------------|--|-------------------------|-------------------------|--------------------------------|
| All Ports   |                         | ETM ports with controller optics mode etm configured                               |                         | Non-ETM ports           |                                |
| Main interface                                      | Subinterface            | Main interface   | Subinterface            | Main interface          | Subinterface                   |
| H-QoS and flat policies                             | H-QoS and flat policies | H-QoS and flat policies  | H-QoS and flat policies | H-QoS and flat policies | No policies, inherit from main |

- The configuration is implemented at the controller level. This means that when you commit the egress traffic management configuration, **all existing configurations are deleted. All existing features and subinterface configurations are deleted and you must reconfigure all of them.**

### Configuration Example for Policy Map with Class Match on traffic-class

To configure an egress traffic management queuing policy and reconfigure policies in **etm** mode for traffic class:

1. Delete the existing **hw-module profile qos hqos-enable** configuration and restart your system.
2. Configure NPU native mode by using the **hw-module profile npu native-mode-enable** command.
3. In the admin mode, reload the router by using the **hw-module reload location all** command.
4. Enable egress traffic management (**etm**) on an interface using the **controller optics** command in the optics controller configuration mode. For 10 GbE interfaces, configure **etm** on the breakout port. After this configuration is enabled, it deletes all subinterfaces under the main interface.
5. Configure the subinterfaces. For policy maps with **match-all** specified for **traffic-class**, run **hw-module profile qos ipv6 short-etm** to truncate IPv6 fields. This configuration frees TCAM space for packet header marking for VOQ lookup in the second pass. Reload the line card.
6. Create the class maps.
7. Specify the match criteria, which can be: match on traffic class, DSCP, CoS, or any combination of these criteria.
8. Set the traffic classes for each class in the policy map.



**Note** The **class-default** need not have a **set-traffic class** value.

9. Specify the traffic class actions.
10. Attach the policy map to the subinterface.

```

/*Delete existing h-qos configuration*/
Router#configure terminal
Router(config)#no hw-module profile qos hqos-enable
In order to activate this new qos profile, you must manually reload the chassis/all line
cards
Router(config)#commit
Router(config)#exit
Router#reload

/* Configure NPU native mode*/
Router#(config)#hw-module profile npu native-mode-enable
In order to activate this new npu profile, you must manually reload the chassis
Router#(config)#commit
Router#(config)#exit
Router#admin
sysadmin-router#hw-module location all reload
Reloading the module will be traffic impacting if not properly drained. Continue to Reload
hardware module ? [no,yes] yes

/*Enable etm on an interface*/
Router#configure terminal
Router(config)#controller optics 0/5/0/16
Router(config-Optics)#mode etm
Router(config-Optics)#commit
Router(config-Optics)#exit

/*To enable etm for breakout ports, as for 10 GbE*/
Router#configure terminal
Router(config)#controller optics 0/5/0/27/1
Router(config-Optics)#mode etm
Router(config-Optics)#commit
Router(config-Optics)#exit

/*Match on traffic-class on ETM-enabled interfaces requires running the following hw-module
command to truncate IPv6 fields, thus freeing TCAM space for packet header marking for
VOQ lookup in the second pass.*/
Router(config)#hw-module profile qos ipv6 short-etm
In order to activate this profile, you must manually reload the chassis/all line cards
Router(config)#commit
Router(config)#exit
Router#reload

/*Configure etm policies on subinterfaces
Configure class map. Specify the match criteria*/
Router(config)#class-map match-any MAIN_OUT_CMAP_1
Router(config-cmap)#match traffic-class 1
Router(config-cmap)#end-class-map
Router(config-cmap)#exit
Router(config)#class-map match-any MAIN_OUT_CMAP_2
Router(config-cmap)#match traffic-class 2
Router(config-cmap)#end-class-map
Router(config-cmap)#exit

```

```

Router(config)#class-map match-any MAIN_OUT_CMAP_3
Router(config-cmap)#match traffic-class 3
Router(config-cmap)#end-class-map
Router(config-cmap)#exit
Router(config)#class-map match-any MAIN_OUT_CMAP_4
Router(config-cmap)#match traffic-class 4
Router(config-cmap)#end-class-map
Router(config-cmap)#exit
Router(config)#class-map match-any MAIN_OUT_CMAP_5
Router(config-cmap)#match traffic-class 5
Router(config-cmap)#end-class-map
Router(config-cmap)#exit
Router(config)#class-map match-any MAIN_OUT_CMAP_6
Router(config-cmap)# match traffic-class 6
Router(config-cmap)#end-class-map
Router(config-cmap)#exit
Router(config)#class-map match-any MAIN_OUT_CMAP_7
Router(config-cmap)#match traffic-class 7
Router(config-cmap)#end-class-map
Router(config-cmap)#exit

/*Create a policy map*/
Router(config)#policy-map MAIN_OUT_PMAP5_PHY_SUB

/*Associate the traffic class with the policy map*/
Router(config-pmap)#class MAIN_OUT_CMAP_1

/*Specify the traffic class actions ('bandwidth remaining ratio, in this example)*/
Router(config-pmap-c)#bandwidth remaining ratio 20
Router(config-pmap-c)#set traffic-class 1
Router(config-cmap-c)#commit
/*Repeat for other classes*/
Router(config-pmap-c)#class MAIN_OUT_CMAP_2
Router(config-pmap-c)#bandwidth remaining ratio 30
Router(config-pmap-c)#set traffic-class 2
Router(config-pmap-c)#exit
Router(config-pmap-c)#class MAIN_OUT_CMAP_3
Router(config-pmap-c)#bandwidth remaining ratio 40
Router(config-pmap-c)#set traffic-class 3
Router(config-pmap-c)#exit
Router(config-pmap-c)#class MAIN_OUT_CMAP_4
Router(config-pmap-c)#bandwidth remaining ratio 50
Router(config-pmap-c)#set traffic-class 4
Router(config-pmap-c)#exit
Router(config-pmap-c)#class MAIN_OUT_CMAP_5
Router(config-pmap-c)#bandwidth remaining ratio 60
Router(config-pmap-c)#set traffic-class 5
Router(config-pmap-c)#exit
Router(config-pmap-c)#class MAIN_OUT_CMAP_6
Router(config-pmap-c)#bandwidth remaining ratio 60
Router(config-pmap-c)#set traffic-class 6
Router(config-pmap-c)#exit
Router(config-pmap-c)#class MAIN_OUT_CMAP_7
Router(config-pmap-c)#set traffic-class 7
Router(config-pmap-c)#priority level 1
Router(config-pmap-c)#exit
Router(config-pmap-c)#class class-default
Router(config-pmap-c)#bandwidth remaining ratio 10
Router(config-pmap-c)#exit
Router(config-pmap-c)#end-policy-map
Router(config)#exit
Router(config)#policy-map PARENT_MAIN_OUT_PHY_SUB

```

```

Router(config-pmap)#class class-default
Router(config-pmap-c)#service-policy MAIN_OUT_PMAP5_PHY_SUB
Router(config-pmap-c)#shape average 55 mbps
Router(config-pmap-c)#exit
Router(config-pmap-c)#end-policy-map
Router(config)#commit

/*Attach the policy map to the subinterface.*/
Router#configure
Router(config)#interface HundredGigE 0/5/0/16.1
Router(config-subif)#service-policy output PARENT_MAIN_OUT_PHY_SUB
Router(config-subif)#commit

```

You have enabled **etm** mode and configured policies in this mode. You are now ready to experience existing QoS features with enhanced egress classification for queuing policy and scale egress queuing policies.

### Running Configuration

```

controller Optics 0/5/0/16
  mode etm
!
class-map match-any MAIN_OUT_CMAP_1
  match traffic-class 1
end-class-map
!
class-map match-any MAIN_OUT_CMAP_2
  match traffic-class 2
end-class-map
!
class-map match-any MAIN_OUT_CMAP_3
  match traffic-class 3
end-class-map
!
class-map match-any MAIN_OUT_CMAP_4
  match traffic-class 4
end-class-map
!
class-map match-any MAIN_OUT_CMAP_5
  match traffic-class 5
end-class-map
!
class-map match-any MAIN_OUT_CMAP_6
  match traffic-class 6
end-class-map
!
class-map match-any MAIN_OUT_CMAP_7
  match traffic-class 7
end-class-map
!
policy-map MAIN_OUT_PMAP5_PHY_SUB
  class MAIN_OUT_CMAP_1
    bandwidth remaining ratio 20
    set traffic-class 1
  !
  class MAIN_OUT_CMAP_2
    bandwidth remaining ratio 30
    set traffic-class 2
  !
  class MAIN_OUT_CMAP_3
    bandwidth remaining ratio 40
    set traffic-class 3
  !
  class MAIN_OUT_CMAP_4

```

```

    bandwidth remaining ratio 50
    set traffic-class 4
!
class MAIN_OUT_CMAP_5
    bandwidth remaining ratio 60
    set traffic-class 5
!
class MAIN_OUT_CMAP_6
    bandwidth remaining ratio 60
    set traffic-class 6
!
class MAIN_OUT_CMAP_7
    set traffic-class 7
    priority level 1
!
class class-default
    bandwidth remaining ratio 10
!
end-policy-map
!
policy-map PARENT_MAIN_OUT_PHY_SUB
class class-default
    service-policy MAIN_OUT_PMAP5_PHY_SUB
    shape average 55 mbps
!
end-policy-map

```

## Verification

To check if interface is in **etm** mode:

```
Router#show controllers npu voq-usage interface all instance all 1$
```

```

-----
Node ID: 0/0/CPU0
Intf Intf NPU NPU PP Sys VOQ Flow VOQ Port
name handle # core Port Port base base port speed
(hex) type
-----
Hu0/0/0/0 8 0 0 1 24577 38400 6912 local 100G
Hu0/0/0/0 8 0 0 154 1 1536 22272 local 100G ----->2nd Entry points to Recycle Port Mapping

```

To verify the output for policy map with class match on traffic class:

```

Router#show qos interface HundredGigE 0/5/0/16.1 output
NOTE:- Configured values are displayed within parentheses
Interface HundredGigE0/5/0/16.1 ifh 0xa008002 -- output policy
NPU Id: 1
Total number of classes: 9
Interface Bandwidth: 100000000 kbps
Policy Name: PARENT_MAIN_OUT_PHY_SUB
SPI Id: 0x0
VOQ Base: 13328
Accounting Type: Layer1 (Include Layer 1 encapsulation and above)
-----
Level1 Class = class-default
Queue Max. BW. = 70311 kbps (55 mbits/sec)
Queue Min. BW. = 58593 kbps (default)
Inverse Weight / Weight = 1 / (BWR not configured)

Level2 Class = MAIN_OUT_CMAP_1
New traffic class = 1
Egressq Queue ID = 13329 (LP queue)
Queue Max. BW. = no max (default)
Queue Min. BW. = 0 kbps (default)

```

```

Inverse Weight / Weight           = 32 / (20)
Peak burst                         = 36864 bytes (default)
TailDrop Threshold                 = 1280 bytes / 19 ms (default)
WRED not configured for this class

Level2 Class                       = MAIN_OUT_CMAP_2
New traffic class                  = 2
Egressq Queue ID                   = 13330 (LP queue)
Queue Max. BW.                     = no max (default)
Queue Min. BW.                     = 0 kbps (default)
Inverse Weight / Weight           = 21 / (30)
Peak burst                         = 36864 bytes (default)
TailDrop Threshold                 = 1280 bytes / 19 ms (default)
WRED not configured for this class

Level2 Class                       = MAIN_OUT_CMAP_3
New traffic class                  = 3
Egressq Queue ID                   = 13331 (LP queue)
Queue Max. BW.                     = no max (default)
Queue Min. BW.                     = 0 kbps (default)
Inverse Weight / Weight           = 16 / (40)
Peak burst                         = 36864 bytes (default)
TailDrop Threshold                 = 1280 bytes / 19 ms (default)
WRED not configured for this class

Level2 Class                       = MAIN_OUT_CMAP_4
New traffic class                  = 4
Egressq Queue ID                   = 13332 (LP queue)
Queue Max. BW.                     = no max (default)
Queue Min. BW.                     = 0 kbps (default)
Inverse Weight / Weight           = 12 / (50)
Peak burst                         = 36864 bytes (default)
TailDrop Threshold                 = 1280 bytes / 19 ms (default)
WRED not configured for this class

Level2 Class                       = MAIN_OUT_CMAP_5
New traffic class                  = 5
Egressq Queue ID                   = 13333 (LP queue)
Queue Max. BW.                     = no max (default)
Queue Min. BW.                     = 0 kbps (default)
Inverse Weight / Weight           = 10 / (60)
Peak burst                         = 36864 bytes (default)
TailDrop Threshold                 = 1280 bytes / 19 ms (default)
WRED not configured for this class

Level2 Class                       = MAIN_OUT_CMAP_6
New traffic class                  = 6
Egressq Queue ID                   = 13334 (LP queue)
Queue Max. BW.                     = no max (default)
Queue Min. BW.                     = 0 kbps (default)
Inverse Weight / Weight           = 10 / (60)
Peak burst                         = 36864 bytes (default)
TailDrop Threshold                 = 1280 bytes / 19 ms (default)
WRED not configured for this class

Level2 Class (HP1)                 = MAIN_OUT_CMAP_7
New traffic class                  = 7
Egressq Queue ID                   = 13335 (HP1 queue)
Queue Max. BW.                     = no max (default)
Peak burst                         = 36864 bytes (default)
TailDrop Threshold                 = 68608 bytes / 10 ms (default)
WRED not configured for this class

Level2 Class                       = class-default

```

```

Egressq Queue ID           = 13328 (Default LP queue)
Queue Max. BW.             = no max (default)
Queue Min. BW.             = 0 kbps (default)
Inverse Weight / Weight    = 64 / (10)
Peak burst                  = 36864 bytes (default)
TailDrop Threshold         = 1280 bytes / 19 ms (default)

```

### Configuration Example for Policy Map with Class Match on DSCP

```

Router(config)#class-map match-any MATCH_DSCP_CONTROL
Router(config-cmap)#description "Customer Control Traffic"
Router(config-cmap)#match dscp 48-58
Router(config-cmap)#end-class-map
Router(config)#class-map match-any MATCH_DSCP_COS1_RT
Router(config-cmap)#description "Real Time Traffic"
Router(config-cmap)#match dscp 40 46
Router(config-cmap)#end-class-map
Router(config)#class-map match-any MATCH_DSCP_COS2_IC
Router(config-cmap)#description "Bursty High In Contract Traffic"
Router(config-cmap)#match dscp 24 26
Router(config-cmap)#end-class-map
Router(config)#class-map match-any MATCH_DSCP_COS2_OC
Router(config-cmap)#description "Bursty High Out of Contract Traffic"
Router(config-cmap)#match dscp 25 27 28 29 30 31
Router(config-cmap)#end-class-map
Router(config)#class-map match-any MATCH_DSCP_COS3_IC
Router(config-cmap)#description "Bursty Low In Contract Traffic"
Router(config-cmap)#match dscp 16 18
Router(config-cmap)#end-class-map
Router(config)#class-map match-any MATCH_DSCP_COS3_OC
Router(config-cmap)#description "Bursty Low Out of Contract Traffic"
Router(config-cmap)#match dscp 17 19 20 21 22 23
Router(config-cmap)#end-class-map
Router(config)#commit

Router(config)#policy-map M4_Ex_1G_Child_80:40:30:30_out_ss
Router(config-pmap)#class MATCH_DSCP_CONTROL
Router(config-pmap-c)#shape average percent 5
Router(config-pmap-c)#set traffic-class 7
Router(config-pmap-c)#priority level 2

Router(config-pmap-c)#class MATCH_DSCP_COS1_RT
Router(config-pmap-c)#shape average percent 80
Router(config-pmap-c)#set traffic-class 5
Router(config-pmap-c)#priority level 1
Router(config-pmap-c)#class MATCH_DSCP_COS2_IC
Router(config-pmap-c)#set traffic-class 2
Router(config-pmap-c)#bandwidth remaining percent 40
Router(config-pmap-c)#queue-limit 4096 packets
Router(config-pmap-c)#class MATCH_DSCP_COS3_IC
Router(config-pmap-c)#bandwidth remaining percent 30
Router(config-pmap-c)#set traffic-class 3
Router(config-pmap-c)#queue-limit 3072 packets
Router(config-pmap-c)#class class-default
Router(config-pmap-c)#bandwidth remaining percent 30
Router(config-pmap-c)#set traffic-class 0
Router(config-pmap-c)#queue-limit 3072 packets
Router(config-pmap-c)#end-policy-map
Router(config)#policy-map M4_Ex_1G_80:40:30:30_out_ss
Router(config-pmap)#class class-default
Router(config-pmap-c)#service-policy M4_Ex_1G_Child_80:40:30:30_out_ss
Router(config-pmap-c)#shape average 100 mbps

```

```

Router(config-pmap-c) #commit
Router(config-pmap-c) #exit
Router(config-pmap) #exit
Router(config) #interface HundredGigE 0/5/0/16.1
Router(config-subif) #service-policy output M4_Ex_1G_80:40:30:30_$
Router(config-subif) #commit

```

### Running Configuration

```

class-map match-any MATCH_DSCP_CONTROL
description "Customer Control Traffic"
match dscp 48-58
end-class-map
!
class-map match-any MATCH_DSCP_COS1_RT
description "Real Time Traffic"
match dscp 40 46
end-class-map
!
class-map match-any MATCH_DSCP_COS2_IC
description "Bursty High In Contract Traffic"
match dscp 24 26
end-class-map
!
class-map match-any MATCH_DSCP_COS3_IC
description "Bursty Low In Contract Traffic"
match dscp 16 18
end-class-map
!
policy-map M4_Ex_1G_Child_80:40:30:30_out_ss
class MATCH_DSCP_CONTROL
shape average percent 5
set traffic-class 7
priority level 2
!
class MATCH_DSCP_COS1_RT
shape average percent 80
set traffic-class 5
priority level 1
!
class MATCH_DSCP_COS2_IC
set traffic-class 2
bandwidth remaining percent 40
queue-limit 4096 packets
!
class MATCH_DSCP_COS3_IC
bandwidth remaining percent 30
set traffic-class 3
queue-limit 3072 packets
!
class class-default
bandwidth remaining percent 30
set traffic-class 0
queue-limit 3072 packets
!
end-policy-map
!
policy-map M4_Ex_1G_80:40:30:30_out_ss
class class-default
service-policy M4_Ex_1G_Child_80:40:30:30_out_ss
shape average 100 mbps
!
end-policy-map

```

## Verify the Output for Policy Map with Class Match on DSCP

```

Router#show qos interface HundredGigE 0/5/0/16.1 output
NOTE:- Configured values are displayed within parentheses
Interface HundredGigE0/5/0/16.1 ifh 0xa008002 -- output policy
NPU Id: 1
Total number of classes: 6
Interface Bandwidth: 100000000 kbps
Policy Name: M4_Ex_1G_80:40:30:30_out_ss
SPI Id: 0x0
VOQ Base: 13328
Accounting Type: Layer1 (Include Layer 1 encapsulation and above)
-----
Level1 Class = class-default
Queue Max. BW. = 113282 kbps (100 mbits/sec)
Queue Min. BW. = 101564 kbps (default)
Inverse Weight / Weight = 1 / (BWR not configured)

Level2 Class (HP2) = MATCH_DSCP_CONTROL
New traffic class = 7
Egressq Queue ID = 13335 (HP2 queue)
Queue Max. BW. = 7812 kbps (5 %)
Guaranteed service rate = 5000 kbps
Peak burst = 36864 bytes (default)
TailDrop Threshold = 6144 bytes / 10 ms (default)
WRED not configured for this class

Level2 Class (HP1) = MATCH_DSCP_COS1_RT
New traffic class = 5
Egressq Queue ID = 13333 (HP1 queue)
Queue Max. BW. = 82031 kbps (80 %)
Guaranteed service rate = 80000 kbps
Peak burst = 36864 bytes (default)
TailDrop Threshold = 99840 bytes / 10 ms (default)
WRED not configured for this class

Level2 Class = MATCH_DSCP_COS2_IC
New traffic class = 2
Egressq Queue ID = 13330 (LP queue)
Queue Max. BW. = no max (default)
Queue Min. BW. = 0 kbps (default)
Inverse Weight / Weight = 2 / (40%)
Guaranteed service rate = 6000 kbps
Peak burst = 36864 bytes (default)
TailDrop Threshold = 1048576 bytes / 1398 ms (4096 packets)
WRED not configured for this class

Level2 Class = MATCH_DSCP_COS3_IC
New traffic class = 3
Egressq Queue ID = 13331 (LP queue)
Queue Max. BW. = no max (default)
Queue Min. BW. = 0 kbps (default)
Inverse Weight / Weight = 2 / (30%)
Guaranteed service rate = 4500 kbps
Peak burst = 36864 bytes (default)
TailDrop Threshold = 786432 bytes / 1398 ms (3072 packets)
WRED not configured for this class

Level2 Class = class-default
New traffic class = 0
Egressq Queue ID = 13328 (Default LP queue)
Queue Max. BW. = no max (default)
Queue Min. BW. = 0 kbps (default)
Inverse Weight / Weight = 2 / (30%)

```

```

Guaranteed service rate           = 4500 kbps
Peak burst                         = 36864 bytes (default)
TailDrop Threshold                 = 786432 bytes / 1398 ms (3072 packets)
WRED not configured for this class

```

### Configuration Example for Policy Map with Class Match on COS

```

Router(config)#class-map match-any cos2
  Router(config-cmap)#match cos 2
Router(config-cmap)#end-class-map
Router(config)#class-map match-all cos3
Router(config-cmap)#match cos 3
Router(config-cmap)#end-class-map
Router(config)#class-map match-all cos4
Router(config-cmap)#match cos 4
Router(config-cmap)#end-class-map
Router(config)#class-map match-all cos5
Router(config-cmap)#match cos 5
Router(config-cmap)#end-class-map
Router(config)#class-map match-all cos6
Router(config-cmap)#match cos 6
Router(config-cmap)#end-class-map
Router(config)#class-map match-all cos7
Router(config-cmap)#match cos 7
Router(config-cmap)#end-class-map
Router(config)#class-map match-all cos1
Router(config-cmap)#match cos 1
Router(config-cmap)#end-class-map
Router(config)#policy-map L2VPN-OUT
Router(config-pmap)#class cos2
Router(config-pmap-c)#set traffic-class 2
Router(config-pmap-c)#shape average 45 mbps
Router(config-pmap-c)#class cos3
Router(config-pmap-c)#set traffic-class 3
Router(config-pmap-c)#shape average 50 mbps
Router(config-pmap-c)#class cos4
Router(config-pmap-c)#set traffic-class 4
Router(config-pmap-c)#shape average 50 mbps
Router(config-pmap-c)#class cos5
Router(config-pmap-c)#set traffic-class 5
Router(config-pmap-c)#shape average 50 mbps
Router(config-pmap-c)#class cos6
Router(config-pmap-c)#set traffic-class 6
Router(config-pmap-c)#shape average 50 mbps
Router(config-pmap-c)#class cos7
Router(config-pmap-c)#set traffic-class 7
Router(config-pmap-c)#shape average 50 mbps
Router(config-pmap-c)#class cos1
Router(config-pmap-c)#set traffic-class 1
Router(config-pmap-c)#shape average 50 mbps
Router(config-pmap-c)#class class-default
Router(config-pmap-c)#shape average 50 mbps
Router(config-pmap-c)#end-policy-map
Router(config)#commit
Router(config)#exit

Router(config)#interface HundredGigE 0/5/0/16.1
Router(config-subif)#no service-policy output
Router(config-subif)#commit

Router(config-subif)#service-policy output L2VPN-OUT

```

```
Router(config-subif)#commit
Router(config-subif)#end
```

### Running Configuration

```
class-map match-any cos2
  match cos 2
end-class-map
!
class-map match-all cos3
  match cos 3
end-class-map
!
class-map match-all cos4
  match cos 4
end-class-map
!
class-map match-all cos5
  match cos 5
end-class-map
!
class-map match-all cos6
  match cos 6
end-class-map
!
class-map match-all cos7
  match cos 7
end-class-map
!
class-map match-all cos1
  match cos 1
end-class-map
!
class-map match-any class-default
end-class-map
!
policy-map L2VPN-OUT
  class cos2
    set traffic-class 2
    shape average 45 mbps
  !
  class cos3
    set traffic-class 3
    shape average 50 mbps
  !
  class cos4
    set traffic-class 4
    shape average 50 mbps
  !
  class cos5
    set traffic-class 5
    shape average 50 mbps
  !
  class cos6
    set traffic-class 6
    shape average 50 mbps
  !
  class cos7
    set traffic-class 7
    shape average 50 mbps
  !
  class cos1
    set traffic-class 1
    shape average 50 mbps
  !
```

```

class class-default
  shape average 50 mbps
!
end-policy-map

```

### Verify the Output for Policy Map with Class Match on COS

```

Router#show qos interface HundredGigE 0/5/0/16.1 output
NOTE:- Configured values are displayed within parentheses
Interface HundredGigE0/5/0/16.1 ifh 0xa008002 -- output policy
NPU Id: 1
Total number of classes: 8
Interface Bandwidth: 100000000 kbps
Policy Name: L2VPN-OUT
SPI Id: 0x0
VOQ Base: 13328
Accounting Type: Layer1 (Include Layer 1 encapsulation and above)
-----
Level1 Class = cos2
New traffic class = 2
Egressq Queue ID = 13330 (LP queue)
Queue Max. BW. = 46875 kbps (45 mbits/sec)
Queue Min. BW. = 0 kbps (default)
Inverse Weight / Weight = 1 / (BWR not configured)
Guaranteed service rate = 45000 kbps
Peak burst = 36864 bytes (default)
TailDrop Threshold = 56064 bytes / 10 ms (default)
WRED not configured for this class

Level1 Class = cos3
New traffic class = 3
Egressq Queue ID = 13331 (LP queue)
Queue Max. BW. = 50781 kbps (50 mbits/sec)
Queue Min. BW. = 0 kbps (default)
Inverse Weight / Weight = 1 / (BWR not configured)
Guaranteed service rate = 50000 kbps
Peak burst = 36864 bytes (default)
TailDrop Threshold = 62464 bytes / 10 ms (default)
WRED not configured for this class

Level1 Class = cos4
New traffic class = 4
Egressq Queue ID = 13332 (LP queue)
Queue Max. BW. = 50781 kbps (50 mbits/sec)
Queue Min. BW. = 0 kbps (default)
Inverse Weight / Weight = 1 / (BWR not configured)
Guaranteed service rate = 50000 kbps
Peak burst = 36864 bytes (default)
TailDrop Threshold = 62464 bytes / 10 ms (default)
WRED not configured for this class

Level1 Class = cos5
New traffic class = 5
Egressq Queue ID = 13333 (LP queue)
Queue Max. BW. = 50781 kbps (50 mbits/sec)
Queue Min. BW. = 0 kbps (default)
Inverse Weight / Weight = 1 / (BWR not configured)
Guaranteed service rate = 50000 kbps
Peak burst = 36864 bytes (default)
TailDrop Threshold = 62464 bytes / 10 ms (default)
WRED not configured for this class

Level1 Class = cos6
New traffic class = 6
Egressq Queue ID = 13334 (LP queue)

```

```

Queue Max. BW. = 50781 kbps (50 mbits/sec)
Queue Min. BW. = 0 kbps (default)
Inverse Weight / Weight = 1 / (BWR not configured)
Guaranteed service rate = 50000 kbps
Peak burst = 36864 bytes (default)
TailDrop Threshold = 62464 bytes / 10 ms (default)
WRED not configured for this class

Levell Class = cos7
New traffic class = 7
Egressq Queue ID = 13335 (LP queue)
Queue Max. BW. = 50781 kbps (50 mbits/sec)
Queue Min. BW. = 0 kbps (default)
Inverse Weight / Weight = 1 / (BWR not configured)
Guaranteed service rate = 50000 kbps
Peak burst = 36864 bytes (default)
TailDrop Threshold = 62464 bytes / 10 ms (default)
WRED not configured for this class

Levell Class = cos1
New traffic class = 1
Egressq Queue ID = 13329 (LP queue)
Queue Max. BW. = 50781 kbps (50 mbits/sec)
Queue Min. BW. = 0 kbps (default)
Inverse Weight / Weight = 1 / (BWR not configured)
Guaranteed service rate = 50000 kbps
Peak burst = 36864 bytes (default)
TailDrop Threshold = 62464 bytes / 10 ms (default)
WRED not configured for this class

Levell Class = class-default
Egressq Queue ID = 13328 (Default LP queue)
Queue Max. BW. = 50781 kbps (50 mbits/sec)
Queue Min. BW. = 0 kbps (default)
Inverse Weight / Weight = 1 / (BWR not configured)
Guaranteed service rate = 50000 kbps
Peak burst = 36864 bytes (default)
TailDrop Threshold = 62464 bytes / 10 ms (default)
WRED not configured for this class

```

### Configuration Example for Policy Map with Class Match on Traffic Class and DSCP

```

Router(config)#class-map match-any cm-dscp-cs1
Router(config-cmap)#match dscp cs1
Router(config-cmap)#class-map match-any cm-dscp-cs2
Router(config-cmap)#match dscp cs2
Router(config-cmap)#class-map match-any cm-dscp-af11
Router(config-cmap)#match dscp af11
Router(config-cmap)#class-map match-any cm-tc-5
Router(config-cmap)#match traffic-class 5
Router(config-cmap)#class-map match-all cm-tc-6-and-dscp-cs3
Router(config-cmap)#match traffic-class 6
Router(config-cmap)#match dscp cs3
Router(config-cmap)#policy-map pm-out-etm-queueing
Router(config-pmap)#class cm-dscp-cs1
Router(config-pmap-c)#set traffic-class 1
Router(config-pmap-c)#shape average percent 45
Router(config-pmap-c)#class cm-dscp-cs2
Router(config-pmap-c)#set traffic-class 1
Router(config-pmap-c)#shape average percent 45
Router(config-pmap-c)#class cm-dscp-af11
Router(config-pmap-c)#set traffic-class 2

```

```

Router(config-pmap-c)#shape average percent 10
Router(config-pmap-c)#class cm-tc-5
Router(config-pmap-c)#shape average percent 5
Router(config-pmap-c)#set traffic-class 3
Router(config-pmap-c)#class cm-tc-6-and-dscp-cs3
Router(config-pmap-c)#set traffic-class 7
Router(config-pmap-c)#priority
Router(config-pmap-c)#commit
Router(config-pmap-c)#exit
Router(config-pmap)#exit
Router(config)#interface HundredGigE 0/5/0/16.1
Router(config-subif)#service-policy output pm-out-etm-queueing
Router(config-subif)#commit
Router(config-subif)#end

```

### Running Configuration

```

class-map match-any cm-dscp-cs1
match dscp cs1
end-class-map
!
class-map match-any cm-dscp-cs2
match dscp cs2
end-class-map
!
class-map match-any cm-dscp-af11
match dscp af11
end-class-map
!
class-map match-any cm-tc-5
match traffic-class 5
end-class-map
!
class-map match-all cm-tc-6-and-dscp-cs3
match traffic-class 6
match dscp af22 cs3
end-class-map
!
policy-map pm-out-etm-queueing
class cm-dscp-cs1
set traffic-class 1
shape average percent 45
!
class cm-dscp-cs2
set traffic-class 1
shape average percent 45
!
class cm-dscp-af11
set traffic-class 2
shape average percent 10
!
class cm-tc-5
shape average percent 5
set traffic-class 3
!
class cm-tc-6-and-dscp-cs3
set traffic-class 7
priority level 1
!
class class-default
!
end-policy-map

```

### Notes on the Configuration Example

- Both the traffic classes **cm-dscp-cs1** and **cm-dscp-cs2** have the same action for set traffic-class in the EM mode, which is **set traffic-class 1**. This means that both these classes have matching traffic going to the same VOQ, and hence their statistics refer to the statistics for VOQ=1.
- The traffic class **cm-dscp-af11** has the action set traffic-class 2 at the recycle pass in the ETM mode. Hence, its matching traffic and statistics are from VOQ=2.
- The traffic class **cm-tc-6-and-dscp-cs3** is an example of remarking traffic-class. This class has traffic-class=6 configured at the ingress, and matches all traffic that has incoming traffic-class=6 AND incoming DSCP=CS3. However, at egress, the traffic-class is remarked to 7. Hence, matching traffic goes to VOQ=7, and the statistics for this class are taken from VOQ=7.

### Verify the Output for Policy Map with Class Match on Traffic Class and DSCP

```

Router#show qos interface HundredGigE 0/5/0/16.1 output
NOTE:- Configured values are displayed within parentheses
Interface HundredGigE0/5/0/16.1 ifh 0xa008002 -- output policy
NPU Id: 1
Total number of classes: 6
Interface Bandwidth: 100000000 kbps
Policy Name: pm-out-etm-queueing
SPI Id: 0x0
VOQ Base: 13328
Accounting Type: Layer1 (Include Layer 1 encapsulation and above)
-----
Level1 Class = cm-dscp-cs1
New traffic class = 1
Egressq Queue ID = 13329 (LP queue)
Queue Max. BW. = 45003261 kbps (45 %)
Queue Min. BW. = 0 kbps (default)
Inverse Weight / Weight = 1 / (BWR not configured)
Peak burst = 36864 bytes (default)
TailDrop Threshold = 1249792 bytes / 10 ms (default)
WRED not configured for this class

Level1 Class = cm-dscp-cs2
New traffic class = 1
Egressq Queue ID = 13329 (LP queue)
Queue Max. BW. = 45003261 kbps (45 %)
Queue Min. BW. = 0 kbps (default)
Inverse Weight / Weight = 1 / (BWR not configured)
Peak burst = 36864 bytes (default)
TailDrop Threshold = 1249792 bytes / 10 ms (default)
WRED not configured for this class

Level1 Class = cm-dscp-af11
New traffic class = 2
Egressq Queue ID = 13330 (LP queue)
Queue Max. BW. = 10000152 kbps (10 %)
Queue Min. BW. = 0 kbps (default)
Inverse Weight / Weight = 1 / (BWR not configured)
Peak burst = 36864 bytes (default)
TailDrop Threshold = 1249792 bytes / 10 ms (default)
WRED not configured for this class

Level1 Class = cm-tc-5
New traffic class = 3
Egressq Queue ID = 13331 (LP queue)
Queue Max. BW. = 5000076 kbps (5 %)
Queue Min. BW. = 0 kbps (default)
Inverse Weight / Weight = 1 / (BWR not configured)
Peak burst = 36864 bytes (default)

```

```

TailDrop Threshold = 1249792 bytes / 10 ms (default)
WRED not configured for this class

Level1 Class (HP1) = cm-tc-6-and-dscp-cs3
New traffic class = 7
Egressq Queue ID = 13335 (HP1 queue)
Queue Max. BW. = no max (default)
Peak burst = 36864 bytes (default)
TailDrop Threshold = 124999936 bytes / 10 ms (default)
WRED not configured for this class

Level1 Class = class-default
Egressq Queue ID = 13328 (Default LP queue)
Queue Max. BW. = no max (default)
Queue Min. BW. = 0 kbps (default)
Inverse Weight / Weight = 1 / (BWR not configured)
Peak burst = 36864 bytes (default)
TailDrop Threshold = 1249792 bytes / 10 ms (default)
WRED not configured for this class

```

### Associated Commands

**controller optics**

## Low Rate Shaper

*Table 3: Feature History Table*

| Feature Name    | Release Information | Feature Description  |
|-----------------|---------------------|--|
| Low Rate Shaper | Release 7.6.1       | <p>This functionality allows your hardware to program low shaper bandwidth with accuracy. Earlier, if one of your customers wanted, say, a bandwidth of 500 kbps, the Cisco NC 57 line card ASIC could only program a minimum bandwidth of 3.9 Mbps for a particular traffic class, resulting in unnecessary wastage of bandwidth. With low shaper rates now made possible, you can limit bandwidth for specific subscribers whose requirements don't call for excessive bandwidth. This functionality thus allows you to save on your bandwidth costs.</p> <p>This functionality is only available for and automatically enabled in the egress traffic management mode.</p> |

- **What is the low rate shaper functionality all about?**—As the name suggests, the functionality is about providing accurate low shaper rate (less than 5 Mbps). But the powerful aspect of this feature is that the low shaper rates that it enables are far lesser what your existing Cisco NC 57 line card ASICs allow.

This functionality is available only when you configure your egress interface in the Egress Traffic Management (Egress TM) mode. It's automatically enabled in this mode.

- **What are the benefits of this functionality?**—This functionality is supported on Cisco NC 57 line cards. The forwarding ASIC in this line card is capable of supporting only 3.9 Mbps as the lowest rate for a particular traffic class, even if you configure a shaping bandwidth less than 3.9 Mbps. When you have a typical network set up that has hundreds of edge-facing routers and thousands of interfaces, this restriction meant that excess bandwidth was distributed even to those subscribers who didn't require it, and hence didn't pay for it.

With this functionality, you can save on your bandwidth costs by limiting the bandwidth for specific subscribers who require a lower spectrum of capacities. Hence, the low-rate shaper also provides you with more accuracy in shaping your hardware's bandwidth. The result is optimal bandwidth distribution and savings for your operations.

- **How does this functionality work? Any important points?**

- When you configure a shaper rate of any value below 5 MBps for the virtual output queue (VOQ) of an ETM-enabled egress interface, the system automatically shifts into low-rate shaper mode.
- Once in low-rate shaper mode, your system supports traffic shaping rates to a particular VOQ in a specific range. This range is from 122 kbps through 80 Gbps.
- To support low-shaping capability, you need to reserve low-rate connectors. The system has 64 connector regions and each region contains 1024 connectors.
- Low connectors get allocated statically during system initialization, and the allocation can't be changed dynamically. You can't use connectors that are reserved and configured as low connectors, as normal connectors, and the converse holds good as well.
- You have the flexibility to reserve the required connectors for low and normal regions before applying all QoS policies at egress.
- A connector switches from low to normal or the other way around if:
  - a low shaper rate (less than 5 Mbps) is detected on any of the traffic classes (VOQ) of an interface, where egress QoS policy map is applied. In this case, all the eight normal connectors are replaced by low connectors.
  - post-policy update or removal, no low shaper rate (less than 5 Mbps) is detected on an egress QoS Policy Map that is applied on VOQs attached with low connectors. In this case, low connectors are replaced by normal connectors.

- **How many egress policy maps can I configure with low rate shaper?**

By default, 2 connector regions per core are reserved for low connectors.

Therefore, per core, the number of low rate connectors are: number of low rate connectors per region x number of connector regions per core = 1024 x 2 = **2048**

Each interface VOQ set requires **8** connectors (or 8 traffic classes).

Therefore, the number of interface VOQ sets (or policy maps) that you can configure per core = number of low rate connectors/number of connectors per interface VOQ set = 2048/8 = **256**

- **Any limitations or restrictions?**

- A low connector can't support more than 80 Gbps traffic shaping rate. Which means that a VOQ attached to a low connector can't forward more than 80 Gbps of traffic.
- Attaching and detaching low connector sets to and from egress interfaces impacts traffic flows in unrelated VOQs. This could affect traffic flows when connectors are switched.
- This functionality is applicable only for local switching on an ETM-enabled egress interface. This is why low-rate shaper benefits do not accrue to ingress traffic from a remote line card.

- **How do I verify the low shaper rate action?**—Run the **show qos interface** command to see the low shaper statistics. For example:

```
router#show qos interface GigabitEthernet 0/2/0/0 output
Level2 Class = exp1
New traffic class = 1
Egressq Queue ID = 1793 (LP queue)
Queue Max. BW. = 3051 kbps (3 mbits/sec)
Queue Min. BW. = 0 kbps (default)
Inverse Weight / Weight = 1 / (BWR not configured)
Guaranteed service rate = 625 kbps
Peak burst = 32832 bytes (default)
TailDrop Threshold = 1280 bytes / 16 ms (default)

LOW SHAPER = Enabled

WRED not configured for this class

Level2 Class = exp2
New traffic class = 2
Egressq Queue ID = 1794 (LP queue)
Queue Max. BW. = 5004 kbps (5 mbits/sec)
Queue Min. BW. = 0 kbps (default)
Inverse Weight / Weight = 1 / (BWR not configured)
Guaranteed service rate = 625 kbps
Peak burst = 32832 bytes (default)
TailDrop Threshold = 1280 bytes / 16 ms (default)

LOW SHAPER = Enabled

WRED not configured for this class
```

# Low Rate Shaper for Enhanced Granularity

Table 4: Feature History Table

| Feature Name                             | Release Information | Feature Description  |
|--|---------------------|--|
| Low Rate Shaper for Enhanced Granularity | Release 24.3.1      | <p>Introduced in this release on: NCS 5700 line cards [Mode: Native]</p> <p>In local Virtual Output Queue (VOQ) switching, you can now achieve precise parent shaper granularity on ETM-enabled interfaces by configuring shared shaper elements in a quad shaper to 0 kbps.</p> <p>This is made possible by enabling a virtual flow using a low-rate connector to the highest-priority queue in the egress pipeline, maintaining the granularity for the four levels of priority and preventing traffic congestion.</p> <p>The feature introduces these changes:</p> <p><b>CLI:</b></p> <ul style="list-style-type: none"> <li><b>hw-module profile qos etm-low-rate-connector npu-id npu-id reserve-conn-range range</b></li> <li><b>hw-module profile qos etm-low-rate-connector npu-id npu-id reserve-conn-range range location node-location</b></li> </ul> <p><b>YANG Data Models:</b></p> <ul style="list-style-type: none"> <li>New Xpaths for <code>Cisco-IOB-XR-hw-module-profile-cfg.yang</code></li> </ul> <p>(see <a href="#">GitHub</a>, <a href="#">YANG Data Models Navigator</a>)</p> |

## Priority Scheduling and Shaping Accuracy on ETM-enabled Interfaces

The enhanced low rate shaper granularity for ETM-enabled interfaces feature significantly improves egress traffic management by ensuring precise parent shaper granularity. This feature also enables

- configuration of 0 kbps shaping rate for shared shaper elements in a quad shaper using virtual flows, and
- four-level priority support preventing unnecessary congestion or slow traffic.

In the Egress Traffic Management (ETM) model, the local VOQ switching hierarchy uses a shared shaper to manage traffic. This shared shaper aggregates four scheduling elements (FQ1, FQ2, FQ3, and CL) into a single shaping unit to achieve four-level priority support. The priority flow of these elements is FQ1 > FQ2 > FQ3 > CL, supporting four levels of bandwidth priority configuration.

Prior to Cisco IOS XR release 24.3.1, the forwarding ASIC in the NCS 5700 line cards was capable of supporting only 3.9 Mbps as the lowest configurable bandwidth for a particular traffic class on all four shaper elements (FQ1, FQ2, FQ3, and CL). This limitation resulted in an additional 11.7 Mbps (3 x 3.9 Mbps) of unexpected bandwidth from the shared shaper elements causing inaccuracies in the parent shaper's traffic management. However, the enhanced low-rate shaper feature enables

By eliminating the additional 11.7 Mbps of unexpected bandwidth, the feature ensures that the parent shaper granularity is more accurate. This enhancement allows for better management of the four levels of priority, ensuring that each level operates as intended without interference from the shared shaper elements.

### How Virtual Flows Enhance Shaper Granularity?

This feature achieves such low-rate shaping accuracy by introducing support for a configurable virtual flow, which is a low-rate connector to the highest-priority queue (FQ1) in the egress pipeline. This virtual flow is connected to the relevant high-priority queue and keeps it active to receive bandwidth credits even though there is no subscriber traffic. The credit tokens are priority propagated to other elements with 0 Kbps shapers.

### Usage Guidelines for Low-rate Shaper Granularity Enhancements

- Supported Cisco NCS 5700 line cards must operate in the native mode only.
- By default, 2048 low-rate connectors are available. However, you can configure to reserve the low-rate connectors per NPU core based on specific QoS scale requirements.
- A virtual flow is configured using the low-rate connector allocated to a shared quad shaper if the shaper value of the parent policy applied on an ETM-enabled interface is less than 500 Mbps.
- Router must have an external TCAM.
- Hierarchical QoS (H-QoS) mode must be disabled.

## Configure a Virtual Flow using Low-rate Connectors

To enable virtual flows, configure to reserve system allocated low-rate connectors for achieving precise shaper granularity at 0 kbps for shared shaper elements on the ETM-enabled interfaces.



---

**Note** To enable this feature, you must configure the shaper value of the parent policy to be less than 500 Mbps.

---

### Before you begin

Before you configure virtual flows, verify

- the NCS 5700 line card is operating in the native mode, and

- the interface is configured in the ETM mode.

## Procedure

**Step 1** Configure a low-rate shaping QoS policy.

### Example:

```
Router(config)#policy-map egr
Router(config-pmap)#class qos-1
Router(config-pmap-c)#shape average 450 mbps
Router(config-pmap-c)#exit
Router(config-pmap)#end-policy-map
Router(config)#commit
```

**Step 2** Attach the QoS policy to an interface.

### Example:

```
Router(config)#interface HundredGigE 0/6/0/18
Router(config-int)#service-policy output egr
Router(config-int)#commit
```

**Step 3** Configure to reserve low-rate connectors:

- For all line cards in a modular router, use the **hw-module profile qos etm-low-rate-connector npu-id *npu-id* reserve-conn-range** command.

### Example:

```
Router(config)#hw-module profile qos etm-low-rate-connector npu-id 0 reserve-conn-range 4
Router(config)#commit
```

- For a specific line card or node in a modular router, use the **hw-module profile qos etm-low-rate-connector npu-id *npu-id* reserve-conn-rangelocationnode-location** command.

### Example:

```
Router(config)#hw-module profile qos etm-low-rate-connector npu-id 0 reserve-conn-range 1 location
0/1/CPU0
Router(config)#commit
```

**Step 4** Verify the virtual flow is configured and active.

### Example:

```
Router#show qos int hu0/0/0/25 output
Fri May 31 16:03:46.130 UTC
NOTE:- Configured values are displayed within parentheses
Interface HundredGigE0/0/0/25 ifh 0x228 -- output policy
NPU Id: 0
Total number of classes: 6
Interface Bandwidth: 100000000 kbps
Policy Name: egr
SPI Id: 0x0
VOQ Base: 2048
PFC enabled: 0
Accounting Type: Layer1 (Include Layer 1 encapsulation and above)
-----
Level1 Class = qos-1
Queue Max. BW. = 453125 kbps (450 mbits/sec)
```

```
Queue Min. BW.                = 453125 kbps (default)
Inverse Weight / Weight       = 1 / (BWR not configured)
Virtual Flow ID              = 98304

Level2 Class (HP2)           = ETC2
New traffic class             = 2
Egressq Queue ID             = 2050 (HP2 queue)
Queue Max. BW.               = no max (default)
Peak burst                   = 36864 bytes (default)
TailDrop Threshold           = 562432 bytes / 10 ms (default)
```

The virtual flow ID is system-generated and specifies that a virtual flow is configured and active for an NPU core using a low-rate connector.

---