



Modular QoS Configuration Guide for Cisco NCS 5500 Series Routers, IOS XR Release 25.1.x, 25.2.x, 25.3.x, 25.4.x

First Published: 2025-03-28

Last Modified: 2025-12-17

Americas Headquarters

Cisco Systems, Inc.
170 West Tasman Drive
San Jose, CA 95134-1706
USA
<http://www.cisco.com>
Tel: 408 526-4000
800 553-NETS (6387)
Fax: 408 527-0883

THE SPECIFICATIONS AND INFORMATION REGARDING THE PRODUCTS IN THIS MANUAL ARE SUBJECT TO CHANGE WITHOUT NOTICE. ALL STATEMENTS, INFORMATION, AND RECOMMENDATIONS IN THIS MANUAL ARE BELIEVED TO BE ACCURATE BUT ARE PRESENTED WITHOUT WARRANTY OF ANY KIND, EXPRESS OR IMPLIED. USERS MUST TAKE FULL RESPONSIBILITY FOR THEIR APPLICATION OF ANY PRODUCTS.

THE SOFTWARE LICENSE AND LIMITED WARRANTY FOR THE ACCOMPANYING PRODUCT ARE SET FORTH IN THE INFORMATION PACKET THAT SHIPPED WITH THE PRODUCT AND ARE INCORPORATED HEREIN BY THIS REFERENCE. IF YOU ARE UNABLE TO LOCATE THE SOFTWARE LICENSE OR LIMITED WARRANTY, CONTACT YOUR CISCO REPRESENTATIVE FOR A COPY.

The Cisco implementation of TCP header compression is an adaptation of a program developed by the University of California, Berkeley (UCB) as part of UCB's public domain version of the UNIX operating system. All rights reserved. Copyright © 1981, Regents of the University of California.

NOTWITHSTANDING ANY OTHER WARRANTY HEREIN, ALL DOCUMENT FILES AND SOFTWARE OF THESE SUPPLIERS ARE PROVIDED "AS IS" WITH ALL FAULTS. CISCO AND THE ABOVE-NAMED SUPPLIERS DISCLAIM ALL WARRANTIES, EXPRESSED OR IMPLIED, INCLUDING, WITHOUT LIMITATION, THOSE OF MERCHANTABILITY, FITNESS FOR A PARTICULAR PURPOSE AND NON-INFRINGEMENT OR ARISING FROM A COURSE OF DEALING, USAGE, OR TRADE PRACTICE.

IN NO EVENT SHALL CISCO OR ITS SUPPLIERS BE LIABLE FOR ANY INDIRECT, SPECIAL, CONSEQUENTIAL, OR INCIDENTAL DAMAGES, INCLUDING, WITHOUT LIMITATION, LOST PROFITS OR LOSS OR DAMAGE TO DATA ARISING OUT OF THE USE OR INABILITY TO USE THIS MANUAL, EVEN IF CISCO OR ITS SUPPLIERS HAVE BEEN ADVISED OF THE POSSIBILITY OF SUCH DAMAGES.

Any Internet Protocol (IP) addresses and phone numbers used in this document are not intended to be actual addresses and phone numbers. Any examples, command display output, network topology diagrams, and other figures included in the document are shown for illustrative purposes only. Any use of actual IP addresses or phone numbers in illustrative content is unintentional and coincidental.

All printed copies and duplicate soft copies of this document are considered uncontrolled. See the current online version for the latest version.

Cisco has more than 200 offices worldwide. Addresses and phone numbers are listed on the Cisco website at www.cisco.com/go/offices.

Cisco and the Cisco logo are trademarks or registered trademarks of Cisco and/or its affiliates in the U.S. and other countries. To view a list of Cisco trademarks, go to this URL: <https://www.cisco.com/c/en/us/about/legal/trademarks.html>. Third-party trademarks mentioned are the property of their respective owners. The use of the word partner does not imply a partnership relationship between Cisco and any other company. (1721R)

© 2025 Cisco Systems, Inc. All rights reserved.



CONTENTS

PREFACE	Preface ix
	Changes to this Document ix
	Communications, Services, and Additional Information ix

CHAPTER 1	New and Changed QoS Features 1
	New and Changed QoS Features 1

CHAPTER 2	YANG Data Models for QoS Features 3
	Using YANG Data Models 3

CHAPTER 3	Key Hardware Resources for QoS 5
	View Packet Processing and Traffic Management Resources 7

CHAPTER 4	Configuring Modular QoS Service Packet Classification 13
	Packet Classification Overview 14
	Traffic Class Elements 16
	Default Traffic Class 18
	Create a Traffic Class 18
	QoS Classification Based on Packet Length 20
	Increase in QoS Policer Allocation on Cisco NCS 5700 Series Line Cards and Routers 23
	Traffic Policy Elements 24
	Create a Traffic Policy 25
	Enhanced Running Configuration Display for Policy Maps and Class Maps 27
	Scaling of Unique Ingress Policy Maps 28
	Limitations and Restrictions 29
	Attach a Traffic Policy to an Interface 29

Configure Maximum Number of Class-Maps per Ingress QoS Traffic Policy	31
Packet Marking	32
Handling QoS for Locally Originated Packets	38
Protecting Locally Originated BFD Packets	41
Prioritization of IS-IS and ARP Packets to Manage Transit Traffic	43
QoS Re-marking of IP Packets in Egress Direction	45
QoS Re-marking of Ethernet Packets in Egress Direction	45
QoS L2 Re-marking of Ethernet Packets in Egress Direction	45
QoS L2 Re-Marking of Ethernet Packets on L3 Flows in Egress Direction	46
QoS L2 Re-Marking of Ethernet Packets on L3 Flows in Egress Direction on L3 sub-interfaces	49
Layer 2 Ingress QoS Matching for IPv4 and IPv6 Destination Addresses	55
Overview	55
Guidelines and Limitations	55
Configure Layer 2 Ingress QoS Matching for IPv4 and IPv6 Destination Addresses	56
Bundle Traffic Policies	58
Shared Policy Instance	59
Restrictions and Guidelines	60
Attaching a Shared Policy Instance to Multiple Subinterfaces	61
Ingress Short-Pipe	62
Restrictions and Other Important Points	63
Configure Ingress Short-Pipe	64
Selective Egress Policy-Based Queue Mapping	66
Restrictions and Other Important Points	67
Configure Selective Egress Policy-Based Queue Mapping	68
Configuring QoS Groups with an ACL	70
Configuring an ACL with Fragment Match	74
Restrictions and Guidelines	75
Configuring an ACL with Fragment Match	75
Restrictions	79
In-Place Policy Modification	82
References for Modular QoS Service Packet Classification	83
Specification of the CoS for a Packet with IP Precedence	83
IP Precedence Bits Used to Classify Packets	83
IP Precedence Value Settings	83

IP Precedence Compared to IP DSCP Marking	84
Conditional Marking of MPLS Experimental bits for L3VPN Traffic	84
QoS DSCP Preservation	85
QoS IP DSCP Preservation for SR-TE	86
QoS DSCP Preservation for mLDP	92
Policy-map for conditional marking of incoming IPv4 and IPv6 traffic	94
Policy-map for conditional marking of outgoing MPLS traffic	95
Conditional Marking of MPLS Experimental bits for L2VPN Traffic	95
Policy-map for conditional marking of incoming traffic	96
Policy-map for conditional marking of outgoing MPLS traffic	97
Conditional Marking of MPLS Experimental Bits for EVPN-VPWS Single-Homing Services	97
Classifying Packets Based On MPLS Experimental Bits in MPLS Over GRE	100
Behavioral Specifications	102
Restrictions	102
Set Up and Configuration for QoS Classification on MPLS Header	102
Terms Used for Classifying Packets Based On MPLS Experimental Bits in MPLS Over GRE	106
QPPB	106
QPPB: Guidelines and Limitations	108
Configuration Workflow	109
Configuring QPPB on an Interface	111
Egress Interface Configuration	111
CHAPTER 5	
Configuring Modular QoS Congestion Avoidance	113
Modular QoS Congestion Avoidance	113
Tail Drop and the FIFO Queue	114
Tail Drop and the FIFO Queue: Tip to Optimize Hardware Resources	114
Configure Tail Drop	115
Fair Adaptive Drop Thresholds	116
How fair adaptive drop thresholds work	117
Fair adaptive drop threshold settings	119
Fair adaptive drop threshold settings and trade-offs	119
Configure fair adaptive drop threshold values	119
Random Early Detection and TCP	120
Configure Random Early Detection	120

Weighted Random Early Detection	122
Average Queue Size for WRED	123
Configure Weighted Random Early Detection	123
Configure WRED Counters by Class	126
Explicit Congestion Notification (ECN)	130
Statistics for ECN-Marked Packets	134
Statistics for ECN-Marked Packets: Guidelines and Limitations	134
Configure to Enable Statistics for ECN-Marked Packets	135
Configure ECN Maximum Marking Probability	136

CHAPTER 6	Link Level Flow Control	141
	Guidelines and limitations for link level flow control	141
	Configure LLFC egress	142
	Mismatched LLFC configurations	143

CHAPTER 7	Priority Flow Control Overview	145
	Restrictions	145
	Configuring Priority Flow Control Thresholds	147
	View Statistics for Priority Flow Control Buffers	153
	View Statistics for Priority Flow Control Buffers: Guidelines	156
	Priority Flow Control Watchdog Overview	156
	Configure a Priority Flow Control Watchdog Interval	156
	Monitoring and Logging Packet Drops on Lossless PFC-Enabled Queues	160
	A Brief Background	160
	Highlights of Logging and Monitoring Packet Drops	160
	Restrictions for Monitoring and Logging Packet Drops	161

CHAPTER 8	Configuring Modular QoS Congestion Management	163
	Congestion Management Overview	163
	Ingress Traffic Management Model	165
	Tell me why this doesn't work as expected	166
	Class-based Weighted Fair Queueing	166
	Bandwidth Remaining	167
	Configure Minimum Bandwidth and Bandwidth Remaining	167

Low-Latency Queuing with Strict Priority Queuing	169
Configuring Low Latency Queuing with Strict Priority queuing	169
Overhead Accounting	172
Traffic Shaping	174
Configure VOQ-Level Traffic Shaping	175
Port Shaping	176
Key Differences Between VOQ-Level and Port-Level Shapers	177
Burst Size for VOQ-Level Shaper	177
Burst Size for Port-Level Shaper	178
Burst Size for Port-Level Shaper: Why	179
Burst Size for Port-Level Shaper: Guidelines and Limitations	179
Configure Burst Size for Port-Level Shaper	180
4K Pseudowire on Bundle with QoS Enhancement	184
Restrictions and Guidelines	185
Configure Two-Level Shaper Policy on Main Interface	185
Traffic Policing	187
Committed Bursts and Excess Bursts	188
Single-Rate Policer	188
Configure Traffic Policing (Single-Rate Two-Color)	189
Configure Traffic Policing (Single-Rate Three-Color)	191
Two-Rate Policer	192
Configure Traffic Policing (Two-Rate Three-Color)	193
Packets-Per-Second-Based Policer	195
Per-thousand and Per-million Units	198
Shared Policer	198
Policer Bucket Shared	199
Policer Bucket Referred	199
Shared Policer Statistics	199
Restrictions and Guidelines	200
Configuring Shared Policer	200
Ingress QoS policer scale enhancement using statistics resource reassignment	202
Guidelines for configuring ingress QoS policer scale enhancement	203
Limitations for configuring ingress QoS policer scale enhancement	204
Configure ingress QoS policer scale enhancement using statistics resource reassignment	204

References for Modular QoS Congestion Management 207

- Committed Bursts 207
- Excess Bursts 207
- Two-Rate Policer Details 208

CHAPTER 9 **Configuring Modular QoS on Link Bundles 209**

- QoS on Link Bundles 209
 - Load Balancing 210
 - Configure QoS on Link Bundles 210
- LAG-level Scheduling in Egress Queuing 215
 - Configure LAG-level Scheduling 217

CHAPTER 10 **Configuring Hierarchical Modular QoS 219**

- Overview of Hierarchical Modular QoS 219
- Restrictions, Limitations, and Requirements for Configuring H-QoS 220
- Configuring Hierarchical Queuing 222
- Conform Aware Hierarchical Policy Overview 227
 - Conform Aware Hierarchical Policy Restrictions 228
 - Configuring Conform Aware Hierarchy Policy 228

CHAPTER 11 **Configure Egress Traffic Management 231**

- Egress Traffic Management 231
- More About the Egress Traffic Management Model 234
- QoS Policy Configuration Rules 236
- Configure Egress Traffic Management 236
- Low Rate Shaper 252
- Low Rate Shaper for Enhanced Granularity 255
 - Configure a Virtual Flow using Low-rate Connectors 256



Preface

This preface contains these sections:

- [Changes to this Document, on page ix](#)
- [Communications, Services, and Additional Information, on page ix](#)

Changes to this Document

This table lists the changes made to this document since it was first published.

Date	Summary
September 2025	Republished for Release 25.3.1.
June 2025	Republished for Release 25.2.1.
March 2025	Initial release of this document

Communications, Services, and Additional Information

- To receive timely, relevant information from Cisco, sign up at [Cisco Profile Manager](#).
- To get the business results you're looking for with the technologies that matter, visit [Cisco Services](#).
- To submit a service request, visit [Cisco Support](#).
- To discover and browse secure, validated enterprise-class apps, products, solutions and services, visit [Cisco DevNet](#).
- To obtain general networking, training, and certification titles, visit [Cisco Press](#).
- To find warranty information for a specific product or product family, access [Cisco Warranty Finder](#).

Cisco Bug Search Tool

[Cisco Bug Search Tool](#) (BST) is a web-based tool that acts as a gateway to the Cisco bug tracking system that maintains a comprehensive list of defects and vulnerabilities in Cisco products and software. BST provides you with detailed defect information about your products and software.



CHAPTER 1

New and Changed QoS Features

- [New and Changed QoS Features, on page 1](#)

New and Changed QoS Features

Table 1: QoS Features Added or Modified

Feature	Description	Changed in Release	Where Documented
Ingress QoS policer scale enhancement using statistics resource reassignment	This feature was introduced.	Release 25.4.1	Ingress QoS policer scale enhancement using statistics resource reassignment, on page 202
Configurable fair adaptive drop thresholds	This feature was introduced.	Release 25.3.1	Fair Adaptive Drop Thresholds , on page 116



CHAPTER 2

YANG Data Models for QoS Features

This chapter provides information about the YANG data models for QoS features.

- [Using YANG Data Models, on page 3](#)

Using YANG Data Models

Cisco IOS XR supports a programmatic way of configuring and collecting operational data of a network device using YANG data models. Although configurations using CLIs are easier and human-readable, automating the configuration using model-driven programmability results in scalability.

The data models are available in the release image, and are also published in the [Github](#) repository. Navigate to the release folder of interest to view the list of supported data models and their definitions. Each data model defines a complete and cohesive model, or augments an existing data model with additional XPath. To view a comprehensive list of the data models supported in a release, navigate to the **Available-Content.md** file in the repository.

You can also view the data model definitions using the [YANG Data Models Navigator](#) tool. This GUI-based and easy-to-use tool helps you explore the nuances of the data model and view the dependencies between various containers in the model. You can view the list of models supported across Cisco IOS XR releases and platforms, locate a specific model, view the containers and their respective lists, leaves, and leaf lists presented visually in a tree structure. This visual tree form helps you get insights into nodes that can help you automate your network.

To get started with using the data models, see the *Programmability Configuration Guide*.



CHAPTER 3

Key Hardware Resources for QoS

QoS implementations rely on various hardware resources to support efficient packet processing and traffic management.

See the table to know more about the key hardware resources that QoS utilizes.

Table 2: Key Hardware Resources that QoS Uses

Resource	Details
Switches and Routers	Switches and routers are fundamental networking devices that play a crucial role in QoS. They are responsible for forwarding traffic based on QoS policies and handling tasks such as packet classification, queuing, and scheduling.
Network Processors	Specialized hardware components designed to handle the processing and forwarding of network traffic. They typically offer high-speed packet processing capabilities, including packet classification, traffic shaping, and queuing tasks.
Traffic Shaper Devices	Hardware devices that regulate the outgoing traffic rate to meet specified bandwidth limits. They typically incorporate algorithms and buffers to shape the traffic flow and smooth out bursts or peaks in network utilization.
Application-Specific Integrated Circuits (ASICs)	ASICs are custom-designed integrated circuits tailored for specific networking tasks. They offer hardware acceleration for essential QoS functions such as packet classification, marking, queuing, and shaping, enabling high-performance and low-latency processing.
Line Cards	Components in networking devices such as switches and routers. They contain the necessary hardware resources, including ASICs, memory, and interfaces, to handle the packet processing and traffic management functions for specific ports or interfaces.

Resource	Details
Memory	Memory resources, including volatile (for example, RAM) and non-volatile (for example, flash memory), are essential for storing and managing QoS-related data, such as traffic classification rules, queuing parameters, and packet buffers.
Interfaces	Network interfaces, such as Ethernet ports or WAN interfaces, are hardware components that connect networking devices to the network. These interfaces often have QoS-related features, such as traffic shaping capabilities or support for differentiated services code points (DSCPs), enabling efficient packet processing and traffic management.

Regardless of whether you're setting up your network and plan to implement QoS or already managing your network and using QoS, it's essential to plan for these resources so you don't run out of them while, for example, deploying topologies for high-scale requirements. An essential part of this implementation is monitoring the availability of QoS resources.

- [View Packet Processing and Traffic Management Resources, on page 7](#)

View Packet Processing and Traffic Management Resources

Table 3: Feature History Table

Feature Name	Release Information	Feature Description
View Packet Processing and Traffic Management Resources	Release 7.11.1	<p>Introduced in this release on: NCS 5500 fixed port routers; NCS 5700 fixed port routers; NCS 5500 modular routers (NCS 5500 line cards; NCS 5700 line cards [Mode: Compatibility; Native])</p> <p>You can now view the utilization of some packet processing and traffic management resources, such as policer banks and connectors. Insights into their consumption and availability help you prevent or mitigate an Out of Resource (OOR) situation, thus ensuring optimal QoS operations with minimal impact on network performance.</p> <p>The feature introduces the following changes:</p> <p>CLI:</p> <p>show controllers npu resources qos</p> <p>YANG:</p> <ul style="list-style-type: none"> • Cisco-IOS-XR-feta-ctrl-npu-qos-resources-qr • Cisco-IOS-XR-5500-qos-oper • Cisco-IOS-XR-feta-ctrl-npu-qos-profile-resources-qr • Cisco-IOS-XR-feta-ctrl-npu-qos-egp-resources-qr <p>(see GitHub, YANG Data Models Navigator)</p>

QoS utilizes hardware resources to classify, mark, and shape traffic. Given that these resources are limited, you require immediate access to information such as their consumption and availability, especially if you plan to implement high-scale setups. Without such information, you may run out of resources, and tracking down the impacted hardware resources could prove challenging.

From Release 7.11.1 onwards, you can view the utilization of some packet processing and traffic management resources by running the [show controllers npu resources qos](#) command. Packet processing and traffic management resources are crucial components of QoS implementations, helping ensure that network traffic is prioritized, managed, and controlled effectively. You can use this data to troubleshoot Out of Resource

(OOR) situations by quickly identifying the exhausted resources or prevent OOR conditions by appropriately modifying their allocation.

Run the `show controllers npu resources qos` command to view the information listed in the table. To best use this information and plan the grouping of multiple resources for specific QoS tasks, you could initially add one policy and check how much of these resources QoS utilizes.

Table 4: Packet Processing and Traffic Management Resources and their Details

Resource	Type	More About This Resource	Important Because
Policer	Packet Processing	The number of policers that are allocated and that you can create. The total number of policer banks is inversely proportional to the class map size.	Helps you determine the ingress policy map scale based on available policer bank resources.
Egress QoS Map Information	Packet Processing	The resources used in creating traffic class and drop precedence (or discard class) maps for egress traffic.	Displays counters for L2 and L3 pools, helping you tune your policy map configurations at the ingress or egress based on the existing policy parameters and optimize the available pool usage.

Resource	Type	More About This Resource	Important Because
Connectors	Traffic Management	The number of NPU connectors or Fabric Access Processors (FAPs) used.	<p>The connector resource dictates the number of VOQs you can create. The egress policy map scale is bound to VOQ availability and, in turn, connector availability.</p> <p>It also tells you, among others:</p> <ul style="list-style-type: none"> • the Reserved number of normal and low rate connector sets for internal VOQ creation; internal VOQs are used for punting and recycling operations. • the Per Interface counter which indicates the number of connectors used per interface or VOQ. <p>Note By default, two connector regions per core are reserved for low connectors, which support lower traffic shaping rates. These low connectors are specific to NCS 5700 line cards [Mode: Native] in the egress traffic management model-mode. (See Egress Traffic Management, on page 231 to know more about this mode.</p>

Resource	Type	More About This Resource	Important Because
Rate Profile	Traffic Management	The rate profile pool used. Interfaces with different line rates and policies with significantly differing shaper and queue lengths use rate profiles.	Helps you tune your egress policy parameters, such as shaper value and queue length, to optimize the available rate profile hardware resources.
Egress Queue (EGQ) Profile	Traffic Management	The number of egress queue maps used. They are consumed when you create egress policies with priority marking.	Helps you tune your egress policy parameters such as egress queue map to optimize the available hardware resources .
VOQ	Traffic Management	The number of Virtual Output Queues (VOQs) used at a global level from a common pool.	Tells you the number of VOQs consumed (Used), the number of VOQs remaining (Free), and the Total number of VOQs available.

Verification

```
Router#show controllers npu resources qos all instance all location 0/0/CPU0
```

```
=====
QoS TM Connectors Information For Location: 0/0/CPU0
```

```
System information for NPU 0:
```

```
Core 0:
```

	Used(%)	Free	Total	Reserved	Per
Interface Consumption					
Normal Connector Set:	384 (0%)	59008	59392	6144	
16					
Lowrate connector Set:	0 (0%)	0	0		

```
Core 1:
```

	Used(%)	Free	Total	Reserved	Per
Interface Consumption					
Normal Connector Set:	384 (0%)	59008	59392	6144	
16					
Lowrate connector Set:	0 (0%)	0	0		

```
=====
QoS TM Rate Profile Information:
```

```
Note: - This is a global resource and shared across all LCs
```

	Used(%)	Free	Total	Reserved	Highest
Used					
3	3 (5%)	56	59	5	

```
=====
QoS TM EGQ Profile Information For Location: 0/0/CPU0
```

```
System information for NPU 0:
```

```
Core 0:
                Used(  %)    Free    Total
                8(100%)     0      8
```

```
Core 1:
                Used(  %)    Free    Total
                8(100%)     0      8
```

```
=====
QoS PP Policer Banks Information For Location: 0/0/CPU0
```

```
System information for NPU 0:
```

```
Core 0:
                Used(  %)    Free    Total    Class-map size
Policer Banks info:  0( 0%)    218    218        32
```

```
Core 1:
                Used(  %)    Free    Total    Class-map size
Policer Banks info:  0( 0%)    218    218        32
```

```
=====
QoS PP Egress QoS Map Information For Location: 0/0/CPU0
```

```
System information for NPU 0:    Used(  %)    Free    Total
L2 Profile Pool:                0( 0%)    14     14
L3 Profile Pool:                0( 0%)    3      3
```

```
=====
QoS VOQ Information For Location: 0/0/CPU0
```

```
Note:- This is a global resources shared by all NPUs
```

```
                Used(  %)    Free    Total
VOQ info:        175( 1%)    11984  12159
```



CHAPTER 4

Configuring Modular QoS Service Packet Classification

This chapter covers these topics:

- [Packet Classification Overview, on page 14](#)
- [Traffic Class Elements, on page 16](#)
- [Traffic Policy Elements, on page 24](#)
- [Ingress Short-Pipe, on page 62](#)
- [Selective Egress Policy-Based Queue Mapping, on page 66](#)
- [Configuring QoS Groups with an ACL, on page 70](#)
- [Configuring an ACL with Fragment Match, on page 74](#)
- [Restrictions , on page 79](#)
- [In-Place Policy Modification, on page 82](#)
- [References for Modular QoS Service Packet Classification, on page 83](#)
- [QPPB, on page 106](#)

Packet Classification Overview

Table 5: Feature History Table

Feature Name	Release Information	Feature Description
Cisco NC57 Compatibility Mode: QoS Enablement on Layer 2 MPLS/BGP	Release 7.3.1	<p>This feature is now supported on routers that have the Cisco NC57 line cards installed and operate in the compatibility mode.</p> <p>The following Layer 2 services are supported:</p> <ul style="list-style-type: none"> • Local switching [xconnect or bridging] • Layer 2 VPN – Virtual Private Wire Service (VPWS) <p>Apart from packet classification, this feature is available for the following QoS operations:</p> <ul style="list-style-type: none"> • Modular QoS Congestion Avoidance , on page 113 • Configuring Modular QoS Congestion Management, on page 163 • QoS on Link Bundles, on page 209 • Configuring Hierarchical Modular QoS, on page 219

Feature Name	Release Information	Feature Description
Cisco NC57 Native Mode: QoS Enablement on Layer 2 Services	Release 7.4.1	<p>This feature is now supported on routers that have the Cisco NC57 line cards installed and operate in the native mode.</p> <p>The following Layer 2 services are supported:</p> <ul style="list-style-type: none"> • Local switching [xconnect or bridging] • Layer 2 VPN – Virtual Private Wire Service (VPWS) <p>Apart from packet classification, this feature is available for the following QoS operations:</p> <ul style="list-style-type: none"> • Modular QoS Congestion Avoidance , on page 113 • Configuring Modular QoS Congestion Management, on page 163 • QoS on Link Bundles, on page 209 • Configuring Hierarchical Modular QoS, on page 219

Packet classification involves categorizing a packet within a specific group (or class) and assigning it a traffic descriptor to make it accessible for QoS handling on the network. The traffic descriptor contains information about the forwarding treatment (quality of service) that the packet should receive. Using packet classification, you can partition network traffic into multiple priority levels or classes of service. The source agrees to adhere to the contracted terms and the network promises a quality of service. Traffic policers and traffic shapers use the traffic descriptor of a packet to ensure adherence to the contract.

Traffic policers and traffic shapers rely on packet classification features, such as IP precedence, to select packets (or traffic flows) traversing a router or interface for different types of QoS service. After you classify packets, you can use other QoS features to assign the appropriate traffic handling policies including congestion management, bandwidth allocation, and delay bounds for each traffic class.

The Modular Quality of Service (QoS) CLI (MQC) defines the traffic flows that must be classified, where each traffic flow is called a class of service, or class. Later, a traffic policy is created and applied to a class. All traffic not identified by defined classes fall into the category of a default class.

You can classify packets at the ingress on L3 subinterfaces for (CoS, DEI) for IPv4, IPv6, and MPLS flows. IPv6 packets are forwarded by paths that are different from those for IPv4. To enable classification of IPv6 packets based on (CoS, DEI) on L3 subinterfaces, run the `hw-module profile qos ipv6 short-l2qos-enable` command and reboot the line card for the command to take effect.

Starting with Cisco IOS XR Release 7.4.1 systems with Cisco NC57 line cards running in native mode support QoS over Layer 2 services for:

- Local switching [xconnect or bridging]
- L2 VPN – VPWS

Guidelines and Limitations

- Ingress CoS marking is not supported on Cisco NCS 5500 Series routers; however, it is supported on Cisco NCS 5700 Series routers.



Note Ingress CoS marking is not supported on L3 interfaces because it can overwrite the Port Control Protocol (PCP) for traffic passing through the core network. To implement CoS marking, always configure it on egress L2 interfaces.

Traffic Class Elements

The purpose of a traffic class is to classify traffic on your router. Use the **class-map** command to define a traffic class.

A traffic class contains three major elements:

- A name
- A series of **match** commands - to specify various criteria for classifying packets.
- An instruction on how to evaluate these **match** commands (if more than one **match** command exists in the traffic class)

Packets are checked to determine whether they match the criteria that are specified in the **match** commands. If a packet matches the specified criteria, that packet is considered a member of the class and is forwarded according to the QoS specifications set in the traffic policy. Packets that fail to meet any of the matching criteria are classified as members of the default traffic class.

This table shows the details of match types that are supported on the router.

Match Type Supported	Min, Max	Max Entries	Support for Match NOT	Support for Ranges	Direction Supported on Interfaces
IPv4 DSCP IPv6 DSCP DSCP	(0,63)	64	Yes	Yes	Ingress
IP encapsulation	(0,63)	64	Yes	Yes	Ingress
IPv4 Precedence IPv6 Precedence Precedence	(0,7)	8	Yes	No	Ingress

Match Type Supported	Min, Max	Max Entries	Support for Match NOT	Support for Ranges	Direction Supported on Interfaces
MPLS Experimental Topmost	(0,7)	8	Yes	No	Ingress
Access-group	Not applicable	8	No	Not applicable	Ingress
QoS-group	(1,7) (1,511) for peering profile	7	No	No	<ul style="list-style-type: none"> • Egress • Ingress for QoS Policy Propagation Using Border Gateway Protocol (QPPB) • Ingress for peering profile
Traffic-class	(1,7)	7	No	No	<ul style="list-style-type: none"> • Egress
Protocol	(0,255)	1	Yes	Not applicable	Ingress



Note Egress queue statistics are displayed only for those classes which have a corresponding match criteria in the egress. Therefore, if you have a **set traffic-class x** configured in the ingress, you must have a corresponding **match traffic-class x** in the egress, in order to see the statistics in the egress side.



Note A maximum value of up to 64 unique queues is supported. Each unique queue-limit consumes one rate profile in the Traffic manager. Out of 64 unique queues, few are reserved for default configs and the remaining are usable.

Depending on the interface speeds, default configurations consume some of the rate profiles. The remaining rate profiles can be exhausted in the following scenarios:

- Different shape rates without configuring queue limits could exhaust the rate profiles as 10ms of guaranteed service rate converts to a different value in bytes based on the shape rate.
- Configuring queue limits in units of time could exhaust the rate profiles. For example, 20 ms of 50 Mbps and 20 ms of 100 Mbps are two different values in bytes.



Tip You can avoid exhausting rate profiles by configuring queue limits in absolute units (such as bytes, kilobytes, or megabytes) for class maps and sharing these limits with the policy maps.

Default Traffic Class

Unclassified traffic (traffic that does not meet the match criteria specified in the traffic classes) is treated as belonging to the default traffic class.

If the user does not configure a default class, packets are still treated as members of the default class. However, by default, the default class has no enabled features. Therefore, packets belonging to a default class with no configured features have no QoS functionality. These packets are then placed into a first in, first out (FIFO) queue and forwarded at a rate determined by the available underlying link bandwidth. This FIFO queue is managed by a congestion avoidance technique called tail drop.

For egress classification, match on **traffic-class** (1-7) is supported. Match **traffic-class 0** cannot be configured. The class-default in the egress policy maps to **traffic-class 0**.

This example shows how to configure a traffic policy for the default class:

```
configure
policy-map ingress_policy1
class class-default
  police rate percent 30
!
```

Create a Traffic Class

To create a traffic class containing match criteria, use the **class-map** command to specify the traffic class name, and then use the **match** commands in class-map configuration mode, as needed.

Guidelines

- Match criteria evaluation order: You can provide multiple values for a match type in a single line of configuration; that is, if the first value does not meet the match criteria, then the next value indicated in the match statement is considered for classification.
- Excluding values with **not** keyword: Use the **not** keyword with the **match** command to perform a match based on the values of a field that are not specified.
- Match commands are optional, but one required: All **match** commands specified in this configuration task are optional, but you must configure at least one match criterion for a class.
- **match-any** versus **match-all** behavior: If you specify **match-any**, one of the match criteria must be met for traffic entering the traffic class to be classified as part of the traffic class. This is the default. If you specify **match-all**, the traffic must match all the match criteria.
- Packet length match support: From Release 7.11.1 onwards, for the **match access-group** command, QoS classification based on the packet length field in the IPv4 and IPv6 headers is supported. Prior to this, support was not available for packet length and TTL (time to live) fields.
- Configuration rejected if invalid ACL used: Deny action in the ACL or an empty ACL (contains no rules, only remarks) is not supported for the **match access-group command** when an ACL list is used within a **class-map**.

The configuration is rejected when you attach such a **policy-map** to an interface.

- Egress matching restrictions: The **traffic-class** and **discard-class** are supported only in egress direction, and these are the only match criteria supported in egress direction.

- Default class matching behavior: The egress default class implicitly matches **qos-group 0** for marking policy and **traffic-class 0** for queuing policy.
- Multicast and unicast egress ratio: Multicast takes a system path that is different than unicast on router, and they meet later on the egress in a multicast-to-unicast ratio of 20:80 on a per interface basis. This ratio is maintained on the same priority level as that of the traffic.
- Multicast QoS prioritization for egress: Egress QoS for multicast traffic treats traffic classes 0-5 as low-priority and traffic classes 6-7 as high priority. Currently, this is not user-configurable.
- Egress shaping not applied to high-priority multicast: Egress shaping does not take effect for multicast traffic in the high priority (HP) traffic classes. It only applies to unicast traffic.
- No egress mapping for ingress classes: If you set a traffic class at the ingress policy and do not have a matching class at egress for the corresponding traffic class value, then the traffic at ingress with this class will not be accounted for in the default class at the egress policy map.
- Only Class 0 maps to default class: Only traffic class 0 falls in the default class. A non-zero traffic class assigned on ingress but with no assigned egress queue, falls neither in the default class nor any other class.
- EDM timeout during line card reload: EDM timeouts for **show policy-map** CLI commands are expected during line card reload with scale configuration.
- Egress rate calculation variation on routers with Cisco NC57 line cards:
 - On Cisco NCS 5700 modular routers (in both compatibility and native modes), the **show policy-map interface** command may display noticeable variations for the egress rates. The ingress rates are displayed accurately.
 - This behavior is specific to routers with external TCAM and more than one NPU.
 - This behavior might not be noticeable when viewing the statistics for the first time but can become evident in subsequent checks. No action is required.

Configuration Example

You have to accomplish the following to complete the traffic class configuration:

1. Creating a class map
2. Specifying the match criteria for classifying the packet as a member of that particular class

(For a list of supported match types, see [Traffic Class Elements, on page 16](#).)

```
Router# configure
Router(config)# class-map match-any qos-1
Router(config-cmap)# match qos-group 1
Router(config-cmap)# end-class-map
Router(config-cmap)# commit
```

Use this command to verify the class-map configuration:

```
Router#show class-map qos-1
1) ClassMap: qos-1    Type: qos
```

Referenced by 2 Policymaps

Also see, [Running Configuration](#), on page 30.

Also see, [Verification](#), on page 30.

Related Topics

- [Traffic Class Elements](#), on page 16
- [Traffic Policy Elements](#), on page 24

Associated Commands

- [class-map](#)
- [match access-group](#)
- [match dscp](#)
- [match mpls experimental topmost](#)
- [match precedence](#)
- [match qos-group](#)

QoS Classification Based on Packet Length

Table 6: Feature History Table

Feature Name	Release Information	Feature Description
QoS Classification Based on Packet Length	Release 7.7.1	<p>You can add an ingress QoS policy on an ACL that filters IPv6 and IPv4 packets based on the packet length. The ACL specifies packet length criteria such as equal to, lesser than, greater than, and so on, to filter packets and prevent distributed-denial-of-service (DDoS) attacks. The QoS policy specifies the forwarding decision.</p> <p>The ACL provides an additional QoS match criteria for IP traffic, thereby providing the combined benefit of network security and traffic classification.</p> <p>This feature is supported on the NCS 5500 Series routers and NCS 5700 Series routers on NC57-18DD-SE and NC57-24DD PIDs.</p>

An ACL consists of one or more access control entries that collectively define the network traffic profile and describe the access rights related to a particular security identifier or user. This profile can then be referenced by Cisco IOS XR software features such as traffic filtering, route filtering, QoS classification, and access control. For more information on packet classification, see [Packet Classification Overview](#). For more information on creating IP ACLs, see the [Understanding Access Lists](#) section in the [IP Addresses and Services Configuration Guide](#).

Guidelines and Limitations for QoS Classification Based on Packet Length

- Packet-length configurations for IPv6 packets with optional extension headers will be classified under **class-default**.
- Now, the **match access-group** command can define the QoS classification based on the packet length field in the IPv6 and IPv4 headers. The **show policy-map interface** command displays the corresponding configuration information.
- To enable IPv6 traffic classification based on the packet length, configure the **hw-module profile qos ipv6 short-l2qos-enable** command in configuration mode.
- You must reload the router for the **hw-module profile qos ipv6 short-l2qos-enable** command to be functional.
- When the packet-length of the IPv6 and IPv4 traffic is considered, the L2 header length is included.

Configure QoS Classification Based on Packet Length

Follow these steps to classify ingress traffic based on the packet length:

- Create an ACL that allows IPv4 traffic with the specified packet length.
- Create QoS class-map and policy-map for ingress IPv4 traffic classification based on its packet length.
- Apply the policy-map on the designated interface.

Configuration Example for QoS Classification Based on Packet Length



Note This example enables traffic filtering for a specific packet length value by using the **packet-length eq** command. Instead of **eq**, you can also use one of these options:

- **gt** to filter packets with a greater value.
- **lt** to filter packets with a lesser value.
- **neq** to filter packets that do not contain the specified value.
- **range** to filter packets in the specified range of values.

```
/* Create an ACL that allows IPv4 traffic with the specified packet length */
```

```
Router# configure
Router(config)# ipv4 access-list aclv4_pktlen
Router(config-ipv4-acl)# 10 permit ipv4 any any packet-length eq 100
Router(config-ipv4-acl)# commit
```

Based on ACL **aclv4_pktlen**, create a QoS policy and apply it on the ingress IPv4 traffic.

```
/* Create QoS class-map and policy-map for ingress IPv4 traffic classification based on its
packet length */
```

```
Router# configure
Router(config)# class-map match-any c_pktlen
Router(config-cmap)# match access-group ipv4 aclv4_pktlen
Router(config-cmap)# end-class-map
```

```

Router(config)# policy-map p_pktlen
Router(config-pmap)# class c_pktlen
Router(config-pmap-c)# set traffic-class 2
Router(config-pmap-c)# exit
Router(config-pmap)# class class-default
Router(config-pmap-c)# end-policy-map
Router(config-pmap-c)# commit
Router(config-pmap-c)# root

```

The policy-map **p_pktlen** is associated with interface HundredGigabitEthernet 0/0/0/0.

```
/* Apply the policy-map on the designated Ethernet interface */
```

```

Router(config)# interface hundredGigE 0/0/0/0
Router(config-if)# service-policy input p_pktlen
Router(config-if)# commit

```

Running Configuration

```
/* Running configuration for QoS Match Packet Length */
```

```

Router# show running-configuration

..
..

ipv4 access-list aclv4_pktlen
 10 permit ipv4 any packet-length eq 100

class-map match-any c_pktlen
 match access-group ipv4 aclv4_pktlen
end-class-map
!
policy-map p_pktlen
 class c_pktlen
   set traffic-class 2
!
class class-default
!
end-policy-map
!
interface HundredGigE0/0/0/0
 service-policy input p_pktlen
!

```

Verification

```
/* This displays the policy information applied in the input direction: */
```

```

Router# show policy-map interface hundredGigE 0/0/0/0 input

HundredGigE0/0/0/0 input: p_pktlen

Class c_pktlen
  Classification statistics          (packets/bytes)      (rate - kbps)
  Matched                          :          53186/54090162      3769
  Transmitted                       :          53186/54090162      3769
  Total Dropped                     :                   0/0                0

Class class-default
  Classification statistics          (packets/bytes)      (rate - kbps)
  Matched                           :                   0/0                0
  Transmitted                       :                   0/0                0

```

Total Dropped : 0/0 0

Policy Bag Stats time: 1657119549887 [Local Time: 07/06/22 14:59:09.887]

Increase in QoS Policer Allocation on Cisco NCS 5700 Series Line Cards and Routers

Table 7: Feature History Table

Feature Name	Release Information	Feature Description
Increase in QoS Policer Scale on Cisco NCS 5700 Series Line Cards and Routers	Release 7.10.1	<p>Introduced in this release on NCS 5700 fixed port routers (select variants only*); NCS 5500 modular routers (NCS 5700 line cards [Mode: Native]) (select variants only*)</p> <p>You can now regulate the incoming traffic bursts and manage traffic spikes with the enhanced scale limit of QoS policers for the following fixed port routers and line cards:</p> <ul style="list-style-type: none"> The Cisco NCS 5700 series fixed port router, NCS-57C3-MOD-SYS, now has an increased scale of 32000 QoS policers, by default The Cisco NCS 5700 series fixed port router, NCS-57B1-6D24-SYS and the Cisco NC57 line card, NC57-24DD installed and operating in native mode, now have an increased scale of 16000 QoS policers, by default
Increase in QoS Policer Allocation on Cisco NCS 5700 Series Line Cards	Release 7.8.1	<p>NCS 5700 Series routers can now handle a maximum of 64000 QoS policers by reallocating unused BGP Flowspec policer resources to QoS.</p> <p>Before this release, the QoS policer count was limited to 32000. With more QoS policers, you can apply policies on more sub-interfaces.</p> <p>This feature is supported on NC57-18DD-SE and NC57-36H-SE line cards.</p> <p>This feature introduces the following command:</p> <ul style="list-style-type: none"> <code>hw-module profile qos policer-scale</code>

Traffic policing involves checking the packet rate for a specific classification of flows to determine if it conforms to specified rate settings. The policer is like a gate that allows a certain number of packets (or bytes) through a network, through physical and logical interfaces. Policers are allocated from the SE line card's Forwarding ASIC for different technologies. 32000 policers are allocated for QoS and BGP Flowspec, each.

To accommodate QoS policing on more sub-interfaces, you can increase the QoS policer count to 64000. However, when you allocate more QoS policers, the BGP Flowspec policer count is reduced. For example, when you allocate 48000 policers for QoS, the default BGP Flowspec pool of 32000 is reduced to 16000. If you do not need or have limited use of Flowspec policers, you can enable this feature to increase QoS policers.

Some examples of increase in QoS policer allocation:

- If you allocate 48000 policers with 16 class-maps, 2999 policer blocks are allocated per core, and 5998 policer blocks are allocated per NPU.
- If you allocate 64000 policers with 16 class maps, 3999 policer blocks are allocated per core, and 7998 policer blocks are allocated per NPU.

Guidelines and Limitations

- This feature is supported only on Cisco NCS 5700 series SE line cards.
- Enhanced QoS mode does not support more than 32000 policers. So, you cannot use this feature with Enhanced QoS mode configuration, which is enabled using the **hw-module profile stats qos-enhanced** command.
- The QoS policer scale numbers are only applicable when the **hw-module profile mdb l3max-se** or **hw-module profile mdb l2max-se** command is enabled. For more information on hardware MDB profiles, see [NCS5700 MDB Profile](#) in the *NCS 5500 System Setup and Software Installation Guide*.

Configure QoS Policer Pool Size

The following example shows how to allocate 48000 QoS policers:

```
RP/0/RP0/CPU0:router# config
RP/0/RP0/CPU0:router(config)# hw-module profile qos policer-scale 48000
RP/0/RP0/CPU0:router(config)# commit
```



Note After you configure, reload the router to apply the profile. Use the **admin hw-module reload location all** command to reload the router.

Traffic Policy Elements

A traffic policy contains three elements:

- Name
- Traffic class
- QoS policies

After choosing the traffic class that is used to classify traffic to the traffic policy, the user can enter the QoS features to be applied to the classified traffic.

The MQC does not necessarily require that the users associate only one traffic class to one traffic policy.

The order in which classes are configured in a policy map is important. The match rules of the classes are programmed into the TCAM in the order in which the classes are specified in a policy map. Therefore, if a packet can possibly match multiple classes, only the first matching class is returned and the corresponding policy is applied.

The router supports 32 classes per policy-map in the ingress direction and 8 classes per policy-map in the egress direction.

This table shows the supported class-actions on the router.

Supported Action Types	Direction supported on Interfaces
minimum-bandwidth	egress
bandwidth-remaining*	egress
mark	(See Packet Marking, on page 32)
police	ingress
priority	egress (level 1 to level 7)
queue-limit	egress
shape	egress
wred	egress

*Bandwidth and Bandwidth remaining configurations are not supported simultaneously within the same policy-map in H-QoS mode.

WRED supports **default** and **discard-class** options; the only values to be passed to the discard-class being 0 and 1.

Create a Traffic Policy

The purpose of a traffic policy is to configure the QoS features that should be associated with the traffic that has been classified in a user-specified traffic class or classes.



Note Starting from Cisco IOS XR Release 7.6.1, the ingress QoS policy you configure, also applies to all the transit Ethernet Connectivity Fault Management (CFM) packets. With QoS features such as marking and policing now applied on the transit CFM packets, you ensure that these packets don't consume excess bandwidth and other QoS resources in the network.

To configure a traffic class, see [Create a Traffic Class, on page 18](#).

After you define a traffic policy with the **policy-map** command, you can attach it to one, or more interfaces to specify the traffic policy for those interfaces by using the **service-policy** command in interface configuration mode. With dual policy support, you can have two traffic policies, one marking and one queuing attached at the output. See, [Attach a Traffic Policy to an Interface, on page 29](#).

Configuration Example

You have to accomplish the following to complete the traffic policy configuration:

1. Creating a policy map that can be attached to one or more interfaces to specify a service policy
2. Associating the traffic class with the traffic policy

3. Specifying the class-action(s) (see [Traffic Policy Elements, on page 24](#))

```
Router# configure
Router(config)# policy-map test-shape-1
Router(config-pmap)# class qos-1

/* Configure class-action ('shape' in this example).
Repeat as required, to specify other class-actions */
Router(config-pmap-c)# shape average percent 40
Router(config-pmap-c)# exit

/* Repeat class configuration as required, to specify other classes */

Router(config-pmap)# end-policy-map
Router(config)# commit
```

See, [Running Configuration, on page 30](#).

See, [Verification, on page 30](#).

Related Topics

- [Traffic Policy Elements, on page 24](#)
- [Traffic Class Elements, on page 16](#)

Associated Commands

- [bandwidth](#)
- [bandwidth remaining](#)
- [class](#)
- [police](#)
- [policy-map](#)
- [priority](#)
- [queue-limit](#)
- [service-policy](#)
- [set discard-class](#)
- [set dscp](#)
- [set mpls experimental](#)
- [set precedence](#)
- [set qos-group](#)
- [shape](#)

Enhanced Running Configuration Display for Policy Maps and Class Maps

Table 8: Feature History Table

Feature Name	Release Information	Feature Description
Enhanced Running Configuration Display for Policy Maps and Class Maps	Release 24.2.1	<p><i>Introduced in this release on: NCS 5500 fixed port routers; NCS 5500 modular routers (NCS 5500 line cards)</i></p> <p>Now, you can view each class map or policy map running configuration instance on a separate line.</p> <p>The feature modifies the output display of this command:</p> <p>CLI: show run formal</p>

Configuration Example

In this example, class maps DSCP and MPLS are associated with the policy map p1, and its **show run formal** output is displayed:

```
/* class map DSCP */

Router# config
Router(config)# class-map match-any DSCP
Router(config-cmap)# match dscp 1
Router(config-cmap)# end-class-map

/* class map MPLS */

Router(config)# class-map match-any MPLS
Router(config-cmap)# match mpls experimental topmost 2
Router(config-cmap)# end-class-map

/* DSCP-to-pl association */

Router(config)# policy-map p1
Router(config-pmap)# class DSCP
Router(config-pmap-c)# bandwidth remaining ratio 80
Router(config-pmap-c)# root

/* MPLS-to-pl association */

Router(config)# policy-map p1
Router(config-pmap)# class MPLS
Router(config-pmap-c)# bandwidth remaining ratio 60
Router(config-pmap-c)# exit
Router(config-pmap)# end-policy-map
Router(config)# commit
```

The following running configuration displays each class map and policy map running configuration instance on a separate line:

```
Router# show run formal
..
class-map match-any DSCP match dscp 1
```

```
class-map match-any MPLS match mpls experimental topmost 2
policy-map p1 class DSCP bandwidth remaining ratio 80
policy-map p1 class MPLS bandwidth remaining ratio 60
..
```

show run and **show run formal** running configuration comparison:

show run displays indented configuration	show run formal displays separate line
<pre>class-map match-any DSCP match dscp 1 end-class-map ! class-map match-any MPLS match mpls experimental topmost 2 end-class-map ! policy-map p1 class DSCP bandwidth remaining ratio 80 ! class MPLS bandwidth remaining ratio 60 ! class class-default ! end-policy-map</pre>	<pre>class-map match-any DSCP ma class-map match-any MPLS ma policy-map p1 class DSCP ba policy-map p1 class MPLS ba</pre>

Scaling of Unique Ingress Policy Maps

Table 9: Feature History Table

Feature Name	Release Information	Feature Description
Scaling of Unique Ingress Policy Maps	Release 7.4.1	This feature is now supported on routers that have Cisco NC57 line cards installed and operate in native mode.
Scaling of Unique Ingress Policy Maps	Release 7.3.1	With this feature, unique policy maps associated to the same template are shared in TCAM, thus enabling scaling of — or creating more number of — policy maps.

Traditionally, when unique policy maps were associated to the same template — that is, having the same match criteria and actions in the *same* order — each map was assigned a different TCAM entry. This resulted in inefficient TCAM entry management and also restricted the number of policy maps that could be created.

With this functionality, unique policy maps associated to the same template are shared in TCAM, thus enabling scaling of—in other words, creating more number of—policy maps. The other way to understand this functionality is that two policy maps with the same combination of criteria and actions use one template. This way, up to 250 templates are supported for association to policy map combinations.

As an example, consider the following policy maps (**policy-map ncs_input1** and **policy-map ncs_input2**) having the same class maps (**class COS7_DEI0** and **class COS7_DEI1**):

```
class-map match-all COS7_DEI0
  match cos 0
end-class-map
class-map match-all COS7_DEI1
  match cos 1
end-class-map

policy-map ncs_input1
  class COS7_DEI0
    set traffic class 1
    police rate 10 mbps
  !
  class COS7_DEI1
    set traffic class 2
    policer rate 20 mbps
  !

policy-map ncs_input2
  class COS7_DEI0
    set traffic class 1
    police rate 30 mbps
  !
  class COS7_DEI1
    set traffic class 2
    policer rate 40 mbps
  !
```

Earlier, when the policy maps were attached to interface, they used different TCAM entries, although the match criteria and actions were the same, except for the policer action.

With this functionality, both policy maps share the TCAM entry instead of selecting different entries, thus freeing up TCAM entries for more policy maps.

Limitations and Restrictions

- Policy Maps share TCAM entries only for the same match criteria and actions or template. However, the policer action can be different for the same template.
- For all unique policy maps the maximum number of templates supported is 250.

Attach a Traffic Policy to an Interface

After the traffic class and the traffic policy are created, you must attach the traffic policy to interface, and specify the direction in which the policy should be applied.



Note When a policy-map is applied to an interface, the transmission rate counter of each class is not accurate. This is because the transmission rate counter is calculated based on the exponential decay filter.

Configuration Example

You have to accomplish the following to attach a traffic policy to an interface:

1. Creating a traffic class and the associated rules that match packets to the class (see [#unique_32](#))
2. Creating a traffic policy that can be attached to one or more interfaces to specify a service policy (see [Create a Traffic Policy, on page 25](#))
3. Associating the traffic class with the traffic policy
4. Attaching the traffic policy to an interface, in the ingress or egress direction

```
Router# configure
Router(config)# interface HundredGigE 0/6/0/18
Router(config-int)# service-policy output test-shape-1
Router(config-int)# commit
```

Running Configuration

```
/* Class-map configuration */

class-map match-any traffic-class-1
  match traffic-class 1
end-class-map
!
- - -
- - -

/* Traffic policy configuration */
policy-map test-shape-1
  class traffic-class-1
    shape average percent 40
  !
  class class-default
  !
end-policy-map
!
- - -
- - -

/* Attaching traffic policy to an interface in egress direction */
interface HundredGigE0/6/0/18
  service-policy output test-shape-1
!
```

Verification

```
Router# show qos interface hundredGigE 0/6/0/18 output
```

NOTE:- Configured values are displayed within parentheses Interface HundredGigE0/6/0/18 ifh

```

0x30001f8 -- output policy
NPU Id: 3
Total number of classes: 2
Interface Bandwidth: 100000000 kbps
VOQ Base: 11112
VOQ Stats Handle: 0x88430698
Accounting Type: Layer1 (Include Layer 1 encapsulation and above)
-----
Level1 Class = qos-1
Egressq Queue ID = 11113 (LP queue)
Queue Max. BW. = 40329846 kbps (40 %)
Queue Min. BW. = 0 kbps (default)
Inverse Weight / Weight = 1 / (BWR not configured)
Guaranteed service rate = 40000000 kbps
TailDrop Threshold = 50069504 bytes / 10 ms (default)
WRED not configured for this class

Level1 Class = class-default
Egressq Queue ID = 11112 (Default LP queue)
Queue Max. BW. = 101803495 kbps (default)
Queue Min. BW. = 0 kbps (default)
Inverse Weight / Weight = 1 / (BWR not configured)
Guaranteed service rate = 50000000 kbps
TailDrop Threshold = 62652416 bytes / 10 ms (default)
WRED not configured for this class
    
```

Related Topics

- [Traffic Policy Elements, on page 24](#)
- [Traffic Class Elements, on page 16](#)

Associated Commands

- [service-policy](#)

Configure Maximum Number of Class-Maps per Ingress QoS Traffic Policy

Table 10: Feature History Table

Feature Name	Release Information	Feature Description
Flexibility to Set a Maximum of One Class Map per Ingress QoS Traffic Policy	Release 7.10.1	<p>Introduced in this release on NCS 5700 fixed port routers; NCS 5500 modular routers (NCS 5700 line cards [Mode: Compatibility; Native])</p> <p>You can now set a maximum of one class map per ingress QoS traffic policy. In earlier releases, the allowed values for maximum number of class maps per ingress traffic policy were 2, 4, 8, 16, and 32.</p> <p>With fewer class maps per traffic policy, the NPU resources required for packet matching are lower. And so this allows you to configure ingress traffic policies on more interfaces of the router.</p> <p>This feature modifies the hw-module profile qos max-classmap-size command to accept the value of 1 for max-classmap-size.</p>

Flexibility to Set a Maximum of Two Class Maps per Ingress QoS Traffic Policy	Release 7.9.1	<p>Introduced in this release on NCS 5700 fixed port routers; NCS 5500 modular routers(NCS 5700 line cards [Mode: Compatibility; Native])</p> <p>You can now set a maximum of two class maps per ingress QoS traffic policy. In earlier releases, the allowed values for maximum number of class maps per ingress traffic policy were 4, 8, 16, and 32.</p> <p>With fewer class maps per traffic policy, the NPU resources required for packet matching are lower. And so this allows you to configure ingress traffic policies on more interfaces of the router.</p> <p>This feature modifies the hw-module profile qos max-classmap-size command to accept the value of 2 for max-classmap-size.</p>
---	---------------	---

When you apply a traffic policy to an interface, NPU resources get allocated. This resource allocation is dependent on the maximum number of class-maps per traffic policy. By default, the maximum number of class-maps per ingress traffic policy is 32. Configure the maximum number of class-maps per ingress traffic policy to a lower value to apply ingress traffic policies on more interfaces of the router.

To set the maximum number of class maps per ingress QoS traffic policy, use the **hw-module profile qos max-classmap-size** *maximum-class-maps-per-policy* command.

Configure Maximum Number of Class Maps per Ingress QoS Traffic Policy

The following example shows how to change the maximum permitted number of class-maps per ingress traffic policy to 16.

```
Router#config
Router(config)#hw-module profile qos max-classmap-size 16
Router(config)#commit
Router(config)#exit
Router# reload
```



Note After the configuration, reload the router for the command to take effect.

Running Configuration

```
Router#show running-configuration | include hw-module
hw-module profile qos max-classmap-size 16
```

Packet Marking

Table 11: Feature History Table

Feature Name	Release Information	Feature Description
Set VXLAN Outer IP Header DSCP Value to 0 on NCS 5700 fixed port routers	Release 24.2.11	<i>Support for this feature is extended to: NCS 5700 fixed port routers;NCS 5700 line cards [Mode: Native]).</i>

Feature Name	Release Information	Feature Description
Set VXLAN Outer IP Header DSCP Value to 0	Release 24.2.1	<p><i>Introduced in this release on: NCS 5500 fixed port routers; NCS 5500 modular routers.</i></p> <p>When a PE device transports IP traffic over a VXLAN tunnel that originates on the device, it automatically sets the DSCP value in the VXLAN outer IP header to 0 (CS0).</p>
Set IP Marking for SRv6 Encapsulation	Release 24.2.1	<p><i>Introduced in this release on: NCS 5500 fixed port routers; NCS 5500 modular routers.</i></p> <p>With this feature support for IP marking for SRv6 packets that are encapsulated, there are some important updates to the QoS behavior.</p> <p>This is an explicit packet marking feature that applies only to ingress QoS policies.</p> <p>As part of this feature, you can set the IPv6 traffic class [0-63] values to use the full range of DSCP (6 bits) using the policy-map-extend command.</p> <p>CLI: This feature introduces these changes:</p> <ul style="list-style-type: none"> • set ip encapsulation • The policy-map-extend keyword is introduced in the srv6 mode microsegment f3216 encapsulation traffic-class command.



Note L2 packet marking is not supported on NC57-24DD and NC57-18DD-SE line cards for Cisco IOS XR Release 7.0.2.

The packet marking feature provides users with a means to differentiate packets based on the designated markings.

Egress packet marking

- The router supports egress packet marking. Match on **discard-class** on egress, if configured, can be used for a marking policy only.
- An egress policy is mandatory to create a user-defined header by stripping the initial 3 bits and copying the DSCP marking to the QoS group.

L2 ingress marking

- **Ingress marking limitations:** For the ingress pop operation, re-marking the customer VLAN tag (CoS, DEI) is not supported.

- **Egress traffic behavior:** The ingress ‘pop VLAN’ is translated to a ‘push VLAN’ for the egress traffic, and (CoS, DEI) marking is supported for newly pushed VLAN tags. If two VLAN tags are pushed to the packet header at the egress side, both inner and outer VLAN tags are marked. For example:

```
rewrite ingress tag pop 1 symmetric
rewrite ingress tag pop 2 symmetric
rewrite ingress tag translate 2-to-1 dot1q/dot1ad <> symmetric
```

VLAN tag details

- **Single tag operations:** When symmetrical pop 1 action is performed, the outer tag (CoS, DEI) is retained as the original frame.
- **Double tag operations:** When symmetrical pop 2 action is performed, the outer tag (CoS, DEI) is retained as the original frame and inner tag (CoS, DEI) is set to 0/0.
- **NC57 line card specifics:** In case of pop action, the outer VLAN tag (CoS, DEI) is retained on NC57 line cards.

IP traffic class imposition for SRv6 encapsulation

Starting Cisco IOS XR Software Release 24.2.1, you can set the IP traffic class imposition for SRv6 encapsulation using the new [set ip encapsulation class-of-service](#) CLI.

This feature allows you to set the DSCP traffic-class marking to 6 bits using the [hw-module profile segment-routing srv6 mode microsegment f3216 encapsulation traffic-class policy-map-extend](#) command. This configuration replaces the 3-bit DSCP marking set by the [hw-module profile segment-routing srv6 mode microsegment f3216 encapsulation traffic-class policy-map](#) command to 6 bits.

Packet Marking Guidelines and Limitations

Avoid conflicting packet marking configurations: While marking a packet, ensure you don’t set the IP DSCP (using the [set dscp](#) command) and the MPLS experimental imposition values (using the [set mpls experimental imposition](#) command) for the same class map. Else, neither the DSCP remarking nor the MPLS EXP values may take effect at the ingress. This will cause, per default QoS behavior, the IP precedence values to be copied to the EXP bits on the imposed packets. Such an action could lead to unintended packets marked as high-priority by your customer being forwarded as high-priority MPLS packets in the network.

Viewing statistics and counters for egress policies: The statistics and counters for the egress marking policy cannot be viewed on the router.

QoS EXP matching for Layer 2 and Layer 3 VPN traffic:

QoS EXP matching for egress doesn’t work for Layer 2 VPN and Layer 3 VPN traffic flowing from:

- Cisco NCS 5700 series line cards at ingress to Cisco NCS 5500 series line cards at the egress and
- Cisco NCS 5500 series line cards at ingress to Cisco NCS 5700 series line cards at egress.

Policy map limits for egress marking:

- For QOS EXP-Egress marking applied on a Layer 3 interface on Cisco NCS550x and NCS55Ax routers, there is a limit of two unique policy maps per NPU. This limit is three unique policy maps per NPU for routers that have the Cisco NC57 line cards installed.

You can apply these policies to as many interfaces as your system resources allow. However, if you apply more than the permitted limit of unique policies, you may encounter unexpected failure.

- For QoS egress marking (CoS, DEI) applied on a Layer 2 interface, there is a limit of 13 unique policy-maps per NPU. If you exceed this number, you may encounter unexpected failure.

Usage guidelines for SRv6 encapsulation marking:

- The **set ip encapsulation class-of-service** command is not allowed in egress QoS policies.
- The IP encapsulation marking (**set ip encapsulation class-of-service**) and the MPLS experimental imposition marking (**set mpls experimental**) features are mutually exclusive. Both the configurations are not allowed at the same time.
- On Cisco NCS 5500 series routers, the **set ip encapsulation class-of-service** command is allowed only when the **policy-map-extend** option is enabled. On Cisco NCS 5700 series routers, the command is supported in native mode without enabling the **policy-map-extend** option.
- The **policy-map-extend** option enables 6-bit DSCP marking for both L2 and L3 modes at the same time. It is not feasible to enable the **policy-map-extend** option exclusively for L2 and L3 modes due to the shared hardware resources for L2 and L3 SRv6 traffic-class.
- To support DSCP marking in NCS 5700, the **propagate** option must be enabled in the SRv6 configurations.
- Before Cisco IOS XR Release 25.1.1: Using the **set ip encapsulation class-of-service** command marked the DSCP value in pure IPv6 and SRv6 inner headers, altering their original DSCP values.

From Cisco IOS XR Release 25.1.1:

- The DSCP values in pure IPv6 and SRv6 inner headers are preserved.
- Only the DSCP value in the SRv6 header is updated or remarked based on the QoS policy.

Header type	Refers to...	Applies to...
Pure IPv6 header	the standard IPv6 packet header, which includes basic fields such as the source address, destination address, traffic class (DSCP), and other protocol-specific information. It doesn't include any additional encapsulation or extension headers.	packets that are not using SRv6 for routing.

Header type	Refers to...	Applies to...
SRv6 header	<p>an IPv6 header with SR extensions.</p> <p>In SRv6, additional information is added to the IPv6 packet through an SR Header (SRH), which contains a list of segments (or routing instructions) to guide the packet through the network.</p> <p>Usually, the SRv6 header DSCP refers to the traffic class field in the outer IPv6 header of a packet with SRv6 encapsulation.</p>	packets with SR encapsulation, where the outer IPv6 header is modified to include routing information, while the inner IPv6 header may also exist within the encapsulated payload.

Supported Packet Marking Operations

This table shows the supported packet marking operations.

Table 12: Supported Ingress Marking Types

Supported Mark Types	Range	Layer	Supports Unconditional Marking	Supports Conditional Marking	Description
DSCP	0-63	L3	Ingress	No	Supported flows: IP to IP, IP to MPLS, MPLS to IP.
precedence	0-7	L3	Ingress	No	Supported flows: IP to IP, IP to MPLS, MPLS to IP.
mpls experimental topmost	0-7	L3	Ingress	No	Supported flows: MPLS to MPLS.
mpls experimental imposition	0-7	L2 L3	Ingress	No	Supported flows: L2 to MPLS, IP to MPLS.
ip encapsulation	0-63	L2 L3	Ingress	No	Used for marking encapsulated SRv6 packets.
DEI	0-1	L2	Ingress	No	Supported flows: L2 to L2, L2 to MPLS.
CoS	0-7	L2	Ingress	No	Supported flows: L2 to L2, L2 to MPLS.

Supported Mark Types	Range	Layer	Supports Unconditional Marking	Supports Conditional Marking	Description
discard-class	0-2	L2 L3	Ingress	No	Used in conjunction with random-detect for discard behavior identification.
qos-group	0-7	L2 L3	Ingress	No	Marks traffic for QoS management.
traffic-class	0-7	L2 L3	Ingress	No	Used for queuing purposes.

Class-based Unconditional Packet Marking

Table 13: Feature History Table

Feature Name	Release Information	Feature Description
Class-based Unconditional Packet Marking	Release 7.4.1	This feature is now supported on routers that have Cisco NC57 line cards installed and operate in native and compatibility modes.

The packet marking feature allows you to partition your network into multiple priority levels or classes of service, as follows:

- Use QoS unconditional packet marking to set the IP precedence or IP DSCP values for packets entering the network. Routers within your network can then use the newly marked IP precedence values to determine how the traffic should be treated.

On ingress direction, after matching the traffic based on either the IP Precedence or DSCP value, you can set it to a particular discard-class. Weighted random early detection (WRED), a congestion avoidance technique, thereby uses discard-class values to determine the probability that a packet is dropped.

If however, you set a discard-class of 3, the packet is dropped at ingress itself.

- Use QoS unconditional packet marking to assign MPLS packets to a QoS group. The router uses the QoS group to determine how to prioritize packets for transmission. To set the traffic class identifier on MPLS packets, use the **set traffic-class** command in policy map class configuration mode.



Note Setting the traffic class identifier does not automatically prioritize the packets for transmission. You must first configure an egress policy that uses the traffic class.



Note • Unless otherwise indicated, the class-based unconditional packet marking for Layer 3 physical interfaces applies to bundle interfaces.

- From IOS XR Release 7.2.1 onwards with NC57 line cards, propagation of PREC->COS marking happens by default on egress Layer 3 subinterfaces. This applies to single and double-tag L3 subinterfaces, and to NC57 line cards in Native mode.

Handling QoS for Locally Originated Packets

What are Locally Originated Packets?

Locally Originated Packets (LOPs) are packets generated and transmitted by the router itself. These differ from transit packets that pass through the router. LOPs include routing protocols, management protocols, and other locally initiated control messages.

Default QoS markings for protocols

The router assigns default precedence or Differentiated Services Code Point (DSCP) values to various locally originated protocols

Protocol or application	Precedence and DSCP value	L2 PCP value
BGP, OSPF, CCM (CSM), BFD, RSVP	<ul style="list-style-type: none"> • Precedence: 6 • DSCP: 48 	<ul style="list-style-type: none"> • BGP: 6 (with or without MPLS encap) • BFD: 7 (with or without MPLS encap)
Telnet, SSH	<ul style="list-style-type: none"> • Precedence: 2 • DSCP: 16 	Not applicable
SNMP	Precedence: 0	6 (with or without MPLS encap)
SSH, SFTP	Not applicable	7 (with or without MPLS encap)

Some protocols such as BGP, RSVP, CFM, and LDP and the management protocols allow setting explicit precedence or DSCP values.

Traffic class assignment by Cisco IOS XR release

Cisco IOS XR release	Traffic class value
Before Release 7.6.1	<ul style="list-style-type: none"> • Locally generated control plane packets, such as IS-IS and BGP, are generated using traffic-class 6. • Locally generated BFD over Bundle (IETF) packets, which are generated on the Network Processing Unit (NPU), are generated using traffic-class 6.

Cisco IOS XR release	Traffic class value
From Release 7.6.1 onwards	<ul style="list-style-type: none"> Locally generated control plane packets, such as IS-IS and BGP, are generated using traffic-class 7. Locally generated BFD over Bundle (IETF) packets, which are generated on the Network Processing Unit (NPU), are generated using traffic-class 7.



Note Bidirectional Forwarding Detection (BFD) uses a DSCP value of 48 (CS6) for single- and multi-hops sessions on NCS55xx.



Note Bidirectional Forwarding Detection (BFD) uses a DSCP value of 63 (IP-ToS 255) for single-hop sessions and IP-ToS 0 for multi-hop sessions on the NCS540 router. Due to an SDK limitation, a DSCP value of 48 is not supported.



Note Bidirectional Forwarding Detection (BFD) uses a DSCP value of 63 (IP-ToS 255) for single-hop sessions and IP-ToS 0 for multi-hop sessions on the NCS560 router. Due to an SDK limitation, a DSCP value of 48 is not supported.

QoS group and traffic-class mapping for LOPs

The QoS group is determined from the three most significant bits (MSBs) of the DSCP, so all LOPs using Class Selector 6 (CS6) will be automatically assigned to QoS group 6. Also, specific protocols use the traffic-class field value 7 for QoS determination. The qos-group is derived from the traffic-class value for these packets, resulting in a match on qos-group 7.

We recommend specific PCP marking for LOPs based on their respective DSCP values.

If LOP packet is injected with...	Then ingress policy map on the subinterface must match on ...	And you set the QoS per...
DSCP marking cs6	qos-group 6	your traffic requirements
DSCP marking cs7	qos-group 7	your traffic requirements

The egress policy is applicable to all LOPs and data traffic exiting the interface to which the policy is attached.

Managing datapath and locally originated packets

On the router, datapath packets and injected packets aren't differentiated if both their traffic classes share the same Virtual Output Queues (VOQs). Therefore, in the case of a congested VOQ, the LOCP packets are dropped. To avoid the LOCP packets drop, Cisco recommends that you have a different traffic class for data path traffic. Alternatively, you can also specify a higher bandwidth for traffic-class 7 (if ingress traffic rate is predictable).

Optimizing traffic handling by early classification and marking

Classifying traffic helps the router to recognize traffic as a certain type and mark that traffic. By marking traffic early on its travel, you can prevent excessive reclassification later. You can mark traffic at the protocol level as shown in the following examples:

Ethernet

The following configuration shows that the outbound Control Hub packets are marked with a precedence value of 2 and EXP of 2, instead of a precedence and EXP value of 6. The SSH packets have a precedence value of 3 instead of 2.

```

ethernet cfm
  mep domain FOO service FOOBAR mep-id 1
    cos 2
ssh server dscp 24

```

BGP

```
neighbor x.x.x.x dscp
```

MPLS LDP

```
mpls ldp signalling dscp
```

Telnet

```
telnet ipv4 dscp
```

SNMP

```
snmp-server ipv4 precedence/dscp
```

Syslog

```

logging ipv4 precedence/dscp
netflow
flow exporter-map TEST dscp

```

NTP

```

ntp ipv4 precedence/dscp
ssh client dscp 56
ssh server dscp 56

```



Note By default, the router marks the Precision Time Protocol (PTP) traffic as high priority. Therefore, the need to prioritize PTP traffic in the QoS configuration is not required.

LOCPs and QoS policies

LOCPs are packets generated by the router itself, such as IS-IS, ARP, and other non-IP-based control packets. These packets are critical for network operations and are treated with high priority to ensure they are not dropped under normal circumstances.



Note By default, all LOCPs are assigned to traffic-class 7. Considering that LOCPs and LOMP are generated by the RP, an Ingress QoS policy cannot be applied. Therefore, you must ensure that the egress QoS policy includes a class-map which matches traffic-class 7. By definition, the egress QoS policy matches all implicitly marked packets.

Key features of LOCPs

Discard priority

- LOCPs originating from the RP or LC CPU have a discard priority set in the appended Buffer Header (BHDR).
- This ensures LOCPs are not dropped internally under normal conditions.
- LOMPs do not have this discard priority and are treated as normal traffic.

Queue management

- LOCPs with discard priority are placed in an implicitly allocated high-priority queue for each physical egress interface.
- During congestion, LOCPs are not subject to Weighted Random Early Detection (WRED) or Tail-drop queue-limit operations.
- The tail-drop queue-limit must be hit before LOCP packets are dropped.

QoS policy configuration

- QoS policies can be attached to physical interfaces or sub-interfaces.
- If attached to sub-interfaces, the operator cannot attach a QoS policy to the physical interface.
- LOCPs are always sent out on the default high-priority queue of the physical interface.

Bandwidth reservation

- A minimum bandwidth of MIN (1% of interface bandwidth, 10 Mbps) is reserved for the default high-priority queue on physical interfaces without a QoS policy.
- If a QoS policy is applied, the minimum bandwidth for the high-priority queue is controlled by the configured policy.

Classification and re-marking

- LOCPs are not subject to traffic policing or re-marking.
- Non-IP LOCPs, such as IS-IS and ARP, are always sent to the high-priority queue, irrespective of the QoS policy.

Session termination prevention

- During over-subscription, LOCP drops may occur, leading to session termination.
- Proper bandwidth allocation and QoS configuration are essential to prevent such scenarios.

Protecting Locally Originated BFD Packets

For releases before Release 7.6.1, BFD packets are injected into traffic-class 6, with drop priority 0 (equivalent of discard-class 0). If transit traffic is also classified into traffic-class 7 and the associated egress queue is congested, BFD packets may be dropped.

From Release 7.6.1, BFD packets are injected into traffic-class 7, with drop priority 0 (equivalent of discard-class 0). If transit traffic is also classified into traffic-class 7 and the associated egress queue is congested, BFD packets may be dropped.

The recommendation is to configure transit traffic-class 7 in the ingress QoS policy with discard-class 1 or 2. You must then configure WRED in the egress QoS policy that drops these packets before dropping discard-class 0.



Note The default queue length is 16 ms.

Example

```
class-map match-any NC
  match traffic-class 6 (for releases before Release 7.6.1)
  match traffic-class 7 (from Release 7.6.1)
!
policy-map CORE-OUT
  class NC
    random-detect discard-class 1 7 ms 8 ms
```

Hardware Programming

```
RP/0/RP0/CPU0:R26-Spine2-5508#sh qos interface hu0/0/0/35 output
NOTE:- Configured values are displayed within parentheses
Interface HundredGigE0/0/0/35 ifh 0x1408 -- output policy
NPU Id: 5
Total number of classes: 2
Interface Bandwidth: 100000000 kbps
Policy Name: 7 wred-out
SPI Id: 0x0
VOQ Base: 1592
Accounting Type: Layer1 (Include Layer 1 encapsulation and above)
-----
Level1 Class = NC
Egressq Queue ID = 1598 (LP queue)
Queue Max. BW. = 20480000 kbps (20 %)
Queue Min. BW. = 0 kbps (default)
Inverse Weight / Weight = 1 / (BWR not configured)
Guaranteed service rate = 20000000 kbps
Peak burst = 33600 bytes (default)
TailDrop Threshold = 40108032 bytes / 16 ms (default)

WRED profile for Discard_Class 1
WRED Min. Threshold = 17563648 bytes (7 ms)
WRED Max. Threshold = 20054016 bytes (8 ms)

Default RED profile
WRED Min. Threshold = 0 bytes (0 ms)
WRED Max. Threshold = 0 bytes (0 ms)

WRED ECN = Disabled
```

Prioritization of IS-IS and ARP Packets to Manage Transit Traffic

Table 14: Feature History Table

Feature Name	Release Information	Feature Description
Prioritization of IS-IS and ARP Packets to Manage Transit Traffic	Release 7.5.1	<p>This feature gives you the option to assign the highest priority to IS-IS and Address Resolution Protocol (ARP) packets in transit. This feature is disabled by default.</p> <p>The feature provides more flexibility in transit traffic management on a per-hop basis and also fine-tunes the traffic profile management for transit traffic.</p> <p>This feature introduces the hw-module profile qos arp-isis-priority-enable command.</p>

Overview of IS-IS and ARP Traffic Prioritization

Transit traffic refers to all traffic that enters an ingress interface, is compared against the forwarding table entries, and forwarded out an egress interface toward its destination. While the exact path of the transit path may not be of interest to the sender or receiver, you may still want some of the Integrated Intermediate System-to-Intermediate System (IS-IS) and Address Resolution Protocol (ARP) transit traffic to be managed and routed efficiently between specific source and destination addresses. You can now achieve higher levels of flexibility and fine-tune the traffic profile management for transit traffic by enabling the ability to assign the highest priority level to IS-IS and ARP traffic on Layer 2 networks.

This feature is useful if you manage environments such as data centers where you have complete end-to-end control over your network, and you want to avoid any drops in IS-IS and ARP traffic during congestion.

Cisco IOS XR Release 7.5.1 introduces the **hw-module profile qos arp-isis-priority-enable** command to enable prioritization of IS-IS and ARP traffic in transit on Layer 2 networks. Configuring this command assigns a priority level of TC 7 to transit traffic.



Note Assigning highest priority levels to IS-IS and ARP traffic lead to higher volumes of ARP traffic and flood high-priority queues, which may cause other traffic to drop. It's best to assign priority levels based on your network configuration and traffic volume.

Guidelines

- This feature is disabled by default. Configure the **hw-module profile qos arp-isis-priority-enable** command to enable prioritization of IS-IS and ARP traffic in transit on Layer 2 networks.
- This feature is supported on routers that have the Cisco NC57 line cards installed and operate in the native and compatibility mode.
- Configuring **hw-module profile qos arp-isis-priority-enable** assigns a priority level of TC 7 for IS-IS and ARP traffic. When this feature is in its default state of disabled, the default priority level is TC 0.

- This feature doesn't allow you to assign TC values.
- Reload the line card for the **hw-module** command to be functional.

Enabling IS-IS and ARP Traffic Prioritization

To enable IS-IS and ARP traffic prioritization, configure the **hw-module profile qos arp-isis-priority-enable** command.

```
Router#config
Router(config)#hw-module profile qos arp-isis-priority-enable
Router(config)#commit
Router(config)#exit
Router# reload location <lc location>
```

Prioritization is based on IS-IS destination MAC address (01:80:c2:00:00:14 and 01:80:c2:00:00:15) and ARP ether type 0x080. When you configure the **hw-module profile qos arp-isis-priority-enable** command, priority level for IS-IS and ARP and traffic is set as TC 7.

Verification

The following example shows the verification command for NC 57 line cards. The assigned priority level is **TC 07**.

```
RP/0/RP0/CPU0:ios#show controllers fia diag 0 "pp vis pkttm" location 0/0/CPU0
```

```
Node ID: 0/0/CPU0
```

```
R/S/I: 0/0/0
```

```
=====
| Packet TM Information Core=0 Results |
=====
| Name | Value | Size |
| | | (bits) |
=====
| Fwd_Action_Destination | 0c353e | 21 |
| type | PORT_ID | 6 |
| value | 353e | 15 |
| Tc | 07 | 3 |
| Dp | 00 | 2 |
| Int_Stat_Meter_Dp_Cmd | 00 | 4 |
| Lag_Lb_Key | 1772 | 16 |
| St_Vsq_Ptr | 00 | 8 |
| Visibility | 01 | 1 |
| System-Headers_Size | 28 | 7 |
| NWK_Header_Truncate_Size | 00 | 8 |
| NWK_Header_Append_Size_Ptr | 02 | 8 |
| Counter_ID_0 | N/A | 0 |
| Counter_ID_1 | N/A | 0 |
| Counter_ID_2 | N/A | 0 |
| Counter_ID_3 | N/A | 0 |
| Counter_ID_4 | N/A | 0 |
| Counter_ID_5 | N/A | 0 |
| Counter_ID_6 | N/A | 0 |
| Counter_ID_7 | 00a000 | 20 |
| Counter_ID_8 | N/A | 0 |
| Counter_ID_9 | N/A | 0 |
| Meter_ID_0 | N/A | 0 |
| Meter_ID_1 | N/A | 0 |
| Meter_ID_2 | N/A | 0 |
| Ethernet_Meter_ID | 02 | 3 |
| sniff0_cmd | 00 | 5 |
```

```

| sniff0_code           | 0009 | 9 |
| sniff0_qualifier     | 00   | 8 |
| sniff1_cmd           | 00   | 5 |
| sniff1_code          | 01e0 | 9 |
| sniff1_qualifier     | 00   | 8 |
| sniff2_cmd           | 00   | 5 |
| sniff2_code          | 0000 | 9 |
| sniff2_qualifier     | 00   | 8 |
=====

```

QoS Re-marking of IP Packets in Egress Direction

The router support the marking of IP DSCP bits of all IP packets to zero, in the egress direction. This feature helps to re-mark the priority of IP packets, which is mostly used in scenarios like IP over Ethernet over MPLS over GRE. This functionality is achieved using the ingress policy-map with **set dscp 0** option configured in class-default.

Configuration Example

```

Router# configure
Router(config)# policy-map ingress-set-dscp-zero-policy
Router(config-pmap)# class class-default
Router(config-pmap-c)# set dscp 0
Router(config-pmap-c)# end-policy-map
Router(config-pmap)# commit

```

Running Configuration

```

policy-map ingress-set-dscp-zero-policy
class class-default
    set dscp 0
!
end-policy-map
!

```

QoS Re-marking of Ethernet Packets in Egress Direction

The router supports Layer 2 marking of Ethernet packets in the egress direction.

QoS L2 Re-marking of Ethernet Packets in Egress Direction

The router supports Layer 2 marking of Ethernet packets in the egress direction.

To enable this feature, you must:

- Configure the policy maps for queuing and marking at the egress interface.
- Set traffic-class in the ingress and use **match traffic-class** in the egress for queuing.
- Ensure that the **set qos-group** command is configured in ingress policy and the corresponding **match qos-group** command is configured in the egress marking policy. If there is no corresponding QoS group, you will experience traffic failure.

The ingress ‘push VLAN’ is translated to ‘pop VLAN’ for the egress traffic. In this case, (CoS, DEI) re-marking is not supported for the VLAN tag. For example:

1. rewrite ingress tag push dot1q/dot1ad \diamond symmetric
2. rewrite ingress tag push dot1q/dot1ad \diamond second-dot1q \diamond symmetric
3. rewrite ingress tag translate 1-to-2 dot1q/dot1ad \diamond second-dot1q \diamond symmetric

Running Configuration

```
policy-map egress-marking
class qos1
set cos 1
!
class qos2
set cos 2
set dei 1
!
class qos3
set cos 3
!
class class-default
set cos 7
!
end-policy-map
!
```

QoS L2 Re-Marking of Ethernet Packets on L3 Flows in Egress Direction

The router supports Layer 2 marking of Ethernet packets on Layer 3 flows in the egress direction.

To enable this feature, you must:

- Configure the policy maps for marking at the egress interface.
- Ensure that the **set qos-group** command is configured in ingress policy and the corresponding **match qos-group** command is configured in the egress marking policy. If there is no corresponding QoS group, you will experience traffic failure.

Restrictions

The following restrictions apply while configuring the Layer 2 marking of Ethernet packets on Layer 3 flows in the egress direction.

- **set discard-class** is not supported in ingress policy with peering mode.
- Egress marking statistics are not available.
- Layer 2 (802.1p) Egress marking is supported on Layer 3 flows for these types of traffic: IP-to-IP, IP-to-MPLS, and MPLS-to-IP traffic.
- Layer 2 marking of Ethernet packets on Layer 3 flows in the egress direction is supported only in the peering mode.

Running Configuration

Ingress Policy:

You must first set up the qos-group at ingress.

```
class-map match-any Class0
  match mpls experimental topmost 0
  match precedence routine
  match dscp 0-7
end-class-map
class-map match-any Class1
  match mpls experimental topmost 1
  match precedence priority
  match dscp 8-15
end-class-map
class-map match-any Class2
  match mpls experimental topmost 2
  match precedence immediate
  match dscp 16-23
end-class-map
class-map match-any Class3
  match mpls experimental topmost 3
  match precedence flash
  match dscp 24-31
end-class-map
class-map match-any Class4
  match mpls experimental topmost 4
  match precedence flash-override
  match dscp 32-39
end-class-map
class-map match-any Class5
  match mpls experimental topmost 5
  match precedence critical
  match dscp 40-47
end-class-map
class-map match-any Class6
  match mpls experimental topmost 6
  match precedence internet
  match dscp 48-55
end-class-map
class-map match-any Class7
  match mpls experimental topmost 7
  match precedence network
  match dscp 56-63
end-class-map
!

policy-map ncs_input
  class Class7
    set traffic-class 7
    set qos-group 7
  !
  class Class6
    set traffic-class 6
    set qos-group 6
  !
  class Class5
    set traffic-class 5
    set qos-group 5
  !
  class Class4
    set traffic-class 4
    set qos-group 4
  !
  class Class3
    set traffic-class 4
    set qos-group 3
```

```

!
class Class2
  set traffic-class 2
  set qos-group 2
!
class Class1
  set traffic-class 2
  set qos-group 1
!
class Class0
  set traffic-class 0
  set qos-group 0
!
end-policy-map
!

```

Egress Policy:

At the egress, run these commands to mark the packets.

```

class-map match-any qos7
match qos-group 7
end-class-map
!
class-map match-any qos6
match qos-group 6
end-class-map
!
class-map match-any qos5
match qos-group 5
end-class-map
!
class-map match-any qos4
match qos-group 4
end-class-map
!
class-map match-any qos3
match qos-group 3
end-class-map
!
class-map match-any qos2
match qos-group 2
end-class-map
!
class-map match-any qos1
match qos-group 1
end-class-map
!

policy-map ncs_output
class qos7
  set cos 7
  set dei 1
!
class qos6
  set cos 6
  set dei 1
!
class qos5
  set cos 5
  set dei 1
!
class qos4
  set cos 4
  set dei 1

```

```

!
class qos3
  set cos 3
  set dei 1
!
class qos2
  set cos 2
  set dei 1
!
class qos1
  set cos 1
  set dei 1
!
end-policy-map
!

```

QoS L2 Re-Marking of Ethernet Packets on L3 Flows in Egress Direction on L3 sub-interfaces

Table 15: Feature History Table

Feature Name	Release Information	Feature Description
Cisco NC57 Native Mode: 802.1p marking	Release 7.4.1	This feature is now supported on routers that have the Cisco NC57 line cards installed and operate in the native mode.

The router supports Layer 2 marking of Ethernet packets on Layer 3 flows in the egress direction on L3 subinterfaces.

To enable this feature, you must:

- Configure the policy maps for marking at the egress interface.
- Ensure that the **set qos-group** command is configured in ingress policy and the corresponding **match qos-group** command is configured in the egress marking policy. If there is no corresponding QoS group, you experience traffic failure.

Restrictions

The following restrictions apply while configuring the Layer 2 marking of Ethernet packets on Layer 3 flows in the egress direction.

- **set discard-class** is not supported in ingress policy with peering mode.
- Egress marking statistics are not available.
- Layer 2 (CoS, DEI) Egress marking is supported on Layer 3 flows on L3 subinterfaces for these types of traffic: IP-to-IP, IP-to-MPLS, and MPLS-to-IP traffic.

Running Configuration

Ingress Policy:

You must first set up the qos-group at ingress. This is applicable only when you want to mark packets at the egress.

```
class-map match-all COS0_DEI0
  match cos 0
  match dei 0
end-class-map
class-map match-all COS0_DEI1
  match cos 0
  match dei 1
end-class-map
class-map match-all COS1_DEI0
  match cos 1
  match dei 0
end-class-map
class-map match-all COS1_DEI1
  match cos 1
  match dei 1
end-class-map
class-map match-all COS2_DEI0
  match cos 2
  match dei 0
end-class-map
class-map match-all COS2_DEI1
  match cos 2
  match dei 1
end-class-map
class-map match-all COS3_DEI0
  match cos 3
  match dei 0
end-class-map
class-map match-all COS3_DEI1
  match cos 3
  match dei 1
end-class-map
class-map match-all COS4_DEI0
  match cos 4
  match dei 0
end-class-map
class-map match-all COS4_DEI1
  match cos 4
  match dei 1
end-class-map
class-map match-all COS5_DEI0
  match cos 5
  match dei 0
end-class-map
class-map match-all COS5_DEI1
  match cos 5
  match dei 1
end-class-map
class-map match-all COS6_DEI0
  match cos 6
  match dei 0
end-class-map
class-map match-all COS6_DEI1
  match cos 6
  match dei 1
end-class-map
class-map match-all COS7_DEI0
  match cos 7
  match dei 0
end-class-map
class-map match-all COS7_DEI1
  match cos 7
  match dei 1
end-class-map
```

```
policy-map ncs_input
  class COS7_DEI0
    set qos-group 7
    set discard-class 0
  !
  class COS7_DEI1
    set qos-group 7
    set discard-class 1
  !
  class COS6_DEI0
    set qos-group 6
    set discard-class 0
  !
  class COS6_DEI1
    set qos-group 6
    set discard-class 1
  !
  class COS5_DEI0
    set qos-group 5
    set discard-class 0
  !
  class COS5_DEI1
    set qos-group 5
    set discard-class 1
  !
  class COS4_DEI0
    set qos-group 4
    set discard-class 0
  !
  class COS4_DEI1
    set qos-group 4
    set discard-class 1
  !
  class COS3_DEI0
    set qos-group 3
    set discard-class 0
  !
  class COS3_DEI1
    set qos-group 3
    set discard-class 1
  !
  class COS2_DEI0
    set qos-group 2
    set discard-class 0
  !
  class COS2_DEI1
    set qos-group 2
    set discard-class 1
  !
  class COS1_DEI0
    set qos-group 1
    set discard-class 0
  !
  class COS1_DEI1
    set qos-group 1
    set discard-class 1
  !
  class COS0_DEI0
    set qos-group 0
    set discard-class 0
  !
  class COS0_DEI1
    set qos-group 0
```

```

    set discard-class 1
  !

```

Egress Policy:

At the egress, run these commands to mark the packets.

```

class-map match-all qos7_dc0
match qos-group 7
match discard-class 0
end-class-map
!
class-map match-all qos7_dc1
match qos-group 7
match discard-class 1
end-class-map
!

class-map match-all qos6_dc0
match qos-group 6
match discard-class 0
end-class-map
!
class-map match-all qos6_dc1
match qos-group 6
match discard-class 1
end-class-map
!

class-map match-all qos5_dc0
match qos-group 5
match discard-class 0
end-class-map
!
class-map match-all qos5_dc1
match qos-group 5
match discard-class 1
end-class-map
!

class-map match-all qos4_dc0
match qos-group 4
match discard-class 0
end-class-map
!
class-map match-all qos4_dc1
match qos-group 4
match discard-class 1
end-class-map
!

class-map match-all qos3_dc0
match qos-group 3
match discard-class 0
end-class-map
!
class-map match-all qos3_dc1
match qos-group 3
match discard-class 1
end-class-map
!

class-map match-all qos2_dc0
match qos-group 2
match discard-class 0
end-class-map
!
class-map match-all qos2_dc1
match qos-group 2

```

```
match discard-class 1
  end-class-map
!
class-map match-all qos1_dc0
match qos-group 1
match discard-class 0
  end-class-map
!
class-map match-all qos1_dc1
match qos-group 1
match discard-class 1
  end-class-map
!
class-map match-all qos0_dc0
match qos-group 0
match discard-class 0
  end-class-map
!
class-map match-all qos0_dc1
match qos-group 0
match discard-class 1
  end-class-map
!

policy-map ncs_output
class qos7_dc0
  set cos 7
  set dei 0
  set mpls experimental imposition 7
!
class qos7_dc1
  set cos 7
  set dei 1
  set mpls experimental imposition 7
!
class qos6_dc0
  set cos 6
  set dei 0
  set mpls experimental imposition 6
!
class qos6_dc1
  set cos 6
  set dei 1
  set mpls experimental imposition 6
!
class qos5_dc0
  set cos 5
  set dei 0
  set mpls experimental imposition 5
!
class qos5_dc1
  set cos 5
  set dei 1
  set mpls experimental imposition 5
!
class qos4_dc0
  set cos 4
  set dei 0
  set mpls experimental imposition 4
!
class qos4_dc1
  set cos 4
  set dei 1
```

```
    set mpls experimental imposition 4
!
class qos3_dc0
  set cos 3
  set dei 0
  set mpls experimental imposition 3
!
class qos3_dc1
  set cos 3
  set dei 1
  set mpls experimental imposition 3
!
class qos2_dc0
  set cos 2
  set dei 0
  set mpls experimental imposition 2
!
class qos2_dc1
  set cos 2
  set dei 1
  set mpls experimental imposition 2
!
class qos1_dc0
  set cos 1
  set dei 0
  set mpls experimental imposition 1
!
class qos1_dc1
  set cos 1
  set dei 1
  set mpls experimental imposition 1
!
class qos0_dc0
  set cos 0
  set dei 0
  set mpls experimental imposition 0
!
class qos0_dc1
  set cos 0
  set dei 1
  set mpls experimental imposition 0
!
end-policy-map
!
```

Layer 2 Ingress QoS Matching for IPv4 and IPv6 Destination Addresses

Table 16: Feature History Table

Feature Name	Release Information	Feature Description
Layer 2 Ingress QoS Matching for IPv4 and IPv6 Destination Addresses	Release 7.5.1	<p>Using this feature, you can match class maps to IPv4 and IPv6 destination addresses on Layer 2 networks. The Layer 2 interface service policy has the relevant class maps, actioning them for ingress QoS operations.</p> <p>This feature provides you with an additional level of classification for aggregated customer traffic at your ingress, thus giving you granular control on traffic flows.</p> <p>This feature introduces the following commands:</p> <ul style="list-style-type: none"> • match destination-address • hw-module profile qos l2-match-dest-addr-v4v6

Overview

As a service provider, you provide Layer 2 connectivity for different classes of customer traffic across your network. With aggregated customer traffic arriving at your ingress, you need to provide differential treatment depending on specific destination addresses for the traffic. Such ability gives you granular control over traffic, allowing you to classify specific traffic flows depending on the type of services for which your customers have signed up.

You can match class maps to IPv4 and IPv6 destination addresses on Layer 2 networks to ensure such granular control. The interface service policy has the relevant class maps, actioning them for ingress QoS marking.

Guidelines and Limitations

- You can match up to 4 IPv4 and IPv6 addresses each in a class.
- For match on IPv6, only up to 64-bit prefix match is supported.
- The L2VPN traffic can be Virtual Private Wire Service (VPWS) or Virtual Private LAN Service (VPLS).
- Redundant and non-redundant pseudowires are supported.
- This feature isn't supported with egress ACL enabled.
- This feature isn't supported on NC57 line cards.
- Traffic classification for VLAN tags is supported as shown in the following table.

VLAN Tag Condition	IPv4 Addresses	IPv6 Addresses	Combination of IPv4 and IPv6 Addresses
With no VLAN tags	<input checked="" type="checkbox"/>	<input checked="" type="checkbox"/>	<input checked="" type="checkbox"/>
With a single VLAN tag	<input checked="" type="checkbox"/>	<input checked="" type="checkbox"/>	<input checked="" type="checkbox"/>
With a double VLAN tag	<input checked="" type="checkbox"/>	<input checked="" type="checkbox"/>	<input checked="" type="checkbox"/>

Configure Layer 2 Ingress QoS Matching for IPv4 and IPv6 Destination Addresses

Perform the following steps to configure Layer 2 ingress QoS matching for IPv4 and IPv6 destination addresses. This example covers:

- **match-all** criteria for an IPv4 address and a Layer 2 classification (**match dscp**) in the same class map.



Note You can use the **match-all** criteria only when you want to match one specific destination address with other Layer 2 classification options such (CoS, DEI) or DSCP.

- **match-any** criteria for IPv4 and IPv6 addresses in the same class map.

1. Enable the ability to match class maps to IPv4 and IPv6 destination addresses on Layer 2 networks. Reload the router for the **hw-module** command to be functional.
2. Create a class map and specify **match-all** criteria for an IPv4 address and DSCP.
3. Create a class map and specify **match-any** criteria for IPv4 and IPv6 addresses.
4. Create a policy map and associate the class maps you created with the traffic policy and specify **class-action**.
5. Attach the policy map to the interface.

Configuration

```
/*Enable the ability to match class maps to IPv4 and IPv6 destination addresses on Layer 2
networks*/
Router(config)#hw-module profile qos l2-match-dest-addr-v4v6
Router(config)#commit
Router#reload

/*Create a class map and specify match-all criteria for an IPv4 address and DSCP*/
Router(config)#class-map match-all ipv4_dst_cs1
Router(config-cmap)#match destination-address ipv4 192.168.1.4 255.255.255.255
Router(config-cmap)#match dscp cs1

/*Create a class map and specify match-any criteria for IPv4 and IPv6 addresses*/
Router(config-cmap)#class-map match-any V4_V6_MATCH
Router(config-cmap)#match destination-address ipv4 10.0.0.0 255.0.0.0
Router(config-cmap)#match destination-address ipv4 20.1.0.0 255.255.0.0
Router(config-cmap)#match destination-address ipv4 20.1.1.1 255.255.255.255
Router(config-cmap)#match destination-address ipv4 30.1.0.1 255.255.255.0
Router(config-cmap)#match destination-address ipv6 101:1:12::1/64
```

```

Router(config-cmap)#match destination-address ipv6 201:1:1::1/32
Router(config-cmap)#match destination-address ipv6 201:1:3::2/64
Router(config-cmap)#match destination-address ipv6 301:1:3::2/64
Router(config-cmap)#commit

/*Create a policy map, associate the class maps with the traffic policy; specify class-action:
 police rate, in this example*/
Router(config-cmap)#policy-map PMAP_L2_V4_V6_MATCH
Router(config-pmap)#class ipv4_dst_cs1
Router(config-pmap-c)#police rate 10 mbps
Router(config-pmap-c-police)#class V4_V6_MATCH
Router(config-pmap-c)#police rate 10 mbps
Router(config-pmap-c-police)#commit

/*Attach the policy map with class-actions that you set in the class maps*/
Router(config-pmap-c-police)#int Bundle-Ether100.2
Router(config-if)#service-policy input PMAP_L2_V4_V6_MATCH
Router(config-if)#commit

```

You have successfully configured Layer 2 ingress QoS matching for IPv4 and IPv6 destination addresses.

Running Configuration

```

qos l2-match-dest-addr-v4v6
!

class-map match-all ipv4_dst_cs1
 match destination-address ipv4 192.168.1.4 255.255.255.255
 match dscp cs1

!

class-map match-any V4_V6_MATCH
 match destination-address ipv4 10.0.0.0 255.0.0.0
 match destination-address ipv4 20.1.0.0 255.255.0.0
 match destination-address ipv4 20.1.1.1 255.255.255.255
 match destination-address ipv4 30.1.0.1 255.255.255.0
 match destination-address ipv6 101:1:12::1/64
 match destination-address ipv6 201:1:1::1/32
 match destination-address ipv6 201:1:3::2/64
 match destination-address ipv6 301:1:3::2/64

!

!

policy-map PMAP_L2_V4_V6_MATCH
 class ipv4_dst_cs1
  police rate 10 mbps
  class V4_V6_MATCH
  police rate 10 mbps

!

!

```

Verification

To verify that the configuration was successful, run the **sh policy-map pmap-name** command for the policy map you created with all class maps associated. The output displays all the **match-any** and **match-all** configurations for IPv4 and IPv6 addresses.

```

Router#sh policy-map pmap-name PMAP_L2_V4_V6_MATCH detail
class-map match-all ipv4_dst_cs1
 match destination-address ipv4 192.168.1.4 255.255.255.255

```

```

match dscp cs1
end-class-map

!
class-map match-any V4_V6_MATCH
match destination-address ipv4 10.0.0.0 255.0.0.0
match destination-address ipv4 20.1.0.0 255.255.0.0
match destination-address ipv4 20.1.1.1 255.255.255.255
match destination-address ipv4 30.1.0.1 255.255.255.0
match destination-address ipv6 101:1:12::1/64
match destination-address ipv6 201:1:1::1/32
match destination-address ipv6 201:1:3::2/64
match destination-address ipv6 301:1:3::2/64
end-class-map
!
policy-map PMAP_L2_V4_V6_MATCH
class ipv4_dst_cs1
  police rate 10 mbps
!

!
class V4_V6_MATCH
  police rate 10 mbps
!
!
class class-default
!
end-policy-map
!
!

Router#sh run interface bundle-ether 100
interface Bundle-Ether100
service-policy input ipv4_dst_cs1
  ipv4 address 192.168.1.4 255.255.255.255
  dscp cs1
service-policy input PMAP_L2_V4_V6_MATCH
  ipv4 address 10.1.0.1 255.255.255.0
  ipv6 address 10:1::1/96
!

```

Bundle Traffic Policies

A policy can be bound to bundles. When a policy is bound to a bundle, the same policy is programmed on every bundle member (port). For example, if there is a policer or shaper rate, the same rate is configured on every port. Traffic is scheduled to bundle members based on the load balancing algorithm.

Both ingress and egress traffic is supported. Percentage-based policies, absolute rate-based policies, and time-based policies are supported.



Note Egress marking is not supported on BVI interfaces.



Note In BVI 2 pass mode COS/DEI based classification using ingress policy-map is not supported on BVI interface.

For details, see [Configure QoS on Link Bundles, on page 210](#).

Shared Policy Instance

Table 17: Feature History Table

Feature Name	Release Information	Feature Description
Shared Policy Instance	Release 7.3.1	This feature allows you to share a single instance of QoS policy across multiple subinterfaces, allowing for aggregate shaping of the subinterfaces to one rate. The ability to facilitate queue consumption in this manner offers the advantage of saving on QoS and hardware resources, while ensuring that the specified rate is not exceeded.
Shared Policy Instance	Release 7.4.1	This feature is now supported on routers that have Cisco NC57 line cards installed and operate in native and compatibility modes.

Traditionally, when services required by your end-customers mapped one-on-one to an interface, attaching the QoS policy-map directly to the interface was the way to meet customer SLAs. However, with increasing demand for triple play configurations—requiring the management of voice and video queues in addition to data queues—you may have several forwarding constructs. This scenario calls for the need to apply an aggregate QoS policy across interfaces to provide the necessary traffic.

After you create the traffic class and traffic policy, you can optionally use a shared policy instance to allocate a single set of QoS resources and share them across a group of subinterfaces.

With shared policy instance, you can share a single instance of a QoS policy across multiple subinterfaces, allowing for aggregate shaping, policing, and marking of the subinterfaces to one rate. All the subinterfaces that share the instance of a QoS policy must belong to the same main interface. The number of subinterfaces that share the QoS policy instance can range from 2 to the maximum number of subinterfaces on the main interface.

When a shared policy instance of a policy map is shared by several subinterfaces, QoS operations such as aggregate shaping, policing, and marking are applied for traffic on all the interfaces that use the same shared policy instance.

Traditionally, policies were bound to interfaces. However, different types of interfaces, such as Layer 2 and Layer 3, can use a single shared-policy-instance, which allows flexibility in the "attachment point" that binds the policy map.

As an example, consider the following policy configuration:

```
policy-map hqos_gold
  class class-default
    service-policy child_hqos_gold
    shape average 20 mbps
  !
```

```

end-policy-map
!
policy-map child_hqos_gold
class voice
  priority level 1
  shape average 64 kbps
!
class video
  priority level 1
  shape average 4 mbps
!
class data
  bandwidth 5 mbps
!
class class-default
!
end-policy-map
!

interface TenGigE 0/1/0/10.300 l2transport
  service-policy output hqos_gold shared-policy-instance hqos_gold_customer1
!
interface TenGigE 0/1/0/10.400 l2transport
  service-policy output hqos_gold shared-policy-instance hqos_gold_customer1
!

```

The keyword **shared-policy-instance** and the instance name **hqos_gold_customer1** identify the subinterfaces that share an aggregate SLA. These are shared on a physical main interface or a bundle member. In other words, in a mix of Layer 2 and Layer 3 subinterfaces in the same shared policy instance, both layers support classification criteria and action.

In the case of bundles, sharing is applicable within a bundle member and not the entire bundle. Depending on the traffic hashing, shared policy instance may or may not take effect across the subinterface under the bundle main interface.

All subinterfaces that share the same shared policy instance share resources as well. Hence, the **show policy-map** statistics values and **show qos** values for all the subinterfaces are the same.

Restrictions and Guidelines

The following restrictions and guidelines apply while configuring shared policy instance for a policy map.

- Subinterfaces that are part of the same shared policy must belong to the same main interface. In other words, subinterfaces of different main interfaces cannot be part of the same shared policy.
- There is no restriction on the number of unique shared policies across a system. However, the limit of maximum number of subinterfaces with QoS policies applies.
- There is no restriction on the number of unique shared policies per main interface, port, core, NPU, or line card.
- You cannot use the same shared policy name on the ingress and egress of the same subinterface.
- Shared policy instance is not supported with multi-policies. For example, on the egress, you cannot apply a marking policy and a queueing policy under a shared policy.
- A shared policy can include a combination of Layer 2 and Layer 3 subinterfaces.

Attaching a Shared Policy Instance to Multiple Subinterfaces

To attach a shared policy instance to multiple subinterfaces:

1. Enter interface configuration mode and configure a subinterface.
2. Attach a policy map to an input or output subinterface for it to be the service policy for that subinterface.

```
RP/0/RP0/CPU0:router(config)#interface HundredGigE0/3/0/0.1
RP/0/RP0/CPU0:router(config-subif)#service-policy output pm-out shared-policy-instance spil
```

Running Configuration

```
interface HundredGigE0/3/0/0.1
service-policy output pm-out shared-policy-instance spil
ipv4 address 20.0.0.1 255.255.255.0
encapsulation dot1q 1
!
```

Verification

The show policy-map shared-policy-instance command includes an option to display counters for the shared policy instance.



-
- Note**
- For bundle subinterfaces, use RP as the location keyword.
 - For physical subinterfaces, use LC as the location keyword.
-

For example, for a physical interface:

```
RP/0/RP0/CPU0:ios#show policy-map shared-policy-instance spil output location 0/3/CPU0
```

```
Shared Policy Instance spil output: pm-out
```

```
Class cm-tc-1
  Classification statistics          (packets/bytes)          (rate - kbps)
  Matched                          :          772637560/1143503679080      9622860
  Transmitted                       :          731260312/1082265352040      5052880
  Total Dropped                     :          41377248/61238327040        4569980
  Queueing statistics
  Queue ID                          :          1433
  Taildropped(packets/bytes)        :          41377248/61238327040
Class class-default
  Classification statistics          (packets/bytes)          (rate - kbps)
  Matched                          :                   0/0                   0
  Transmitted                       :                   0/0                   0
  Total Dropped                     :                   0/0                   0
  Queueing statistics
  Queue ID                          :          1432
  Taildropped(packets/bytes)        :                   0/0
Policy Bag Stats time: 1604675533816 [Local Time: 11/06/20 15:12:13.816]
```

Use the **clear qos counters shared-policy-instance** command to clear counters for the shared policy instance.



-
- Note**
- For bundle subinterfaces, use RP as the location keyword.
 - For physical subinterfaces, use LC as the location keyword.
-

For example, for a physical interface:

```
RP/0/RP0/CPU0:ios#clear qos counters shared-policy-instance spil output location 0/3/CPU0
```

The **show qos shared-policy-instance** command allows you to display the QoS hardware programming values.



-
- Note**
- For bundle subinterfaces, use RP as the location keyword.
 - For physical subinterfaces, use LC as the location keyword.
-

For example, for a physical interface:

```
RP/0/RP0/CPU0:ios#show qos shared-policy-instance spil output location 0/3/CPU0
```

```
Fri Nov 6 15:21:44.200 UTC
```

```
NOTE:- Configured values are displayed within parentheses
```

```
Interface HundredGigE0/3/0/0.1 ifh 0x60040c8 -- output policy
```

```
NPU Id: 0
Total number of classes: 2
Interface Bandwidth: 100000000 kbps
Policy Name: pm-out
SPI Id: 0x3000001
VOQ Base: 1432
Accounting Type: Layer1 (Include Layer 1 encapsulation and above)
```

```
-----
Level1 Class = cm-tc-1
Egressq Queue ID = 1433 (LP queue)
Queue Max. BW. = 5118857 kbps (5 %)
Queue Min. BW. = 0 kbps (default)
Inverse Weight / Weight = 1 / (BWR not configured)
Guaranteed service rate = 5000000 kbps
Peak burst = 33600 bytes (default)
TailDrop Threshold = 6258688 bytes / 10 ms (default)
WRED not configured for this class
```

```
Level1 Class = class-default
Egressq Queue ID = 1432 (Default LP queue)
Queue Max. BW. = no max (default)
Queue Min. BW. = 0 kbps (default)
Inverse Weight / Weight = 1 / (BWR not configured)
Guaranteed service rate = 50000000 kbps
Peak burst = 33600 bytes (default)
TailDrop Threshold = 62652416 bytes / 10 ms (default)
WRED not configured for this class
```

Ingress Short-Pipe

When QoS traffic leaves an MPLS network, the MPLS label stack is removed on the penultimate ingress Label Switch Router (LSR), leaving an IPv4 or IPv6 packet to be forwarded. MPLS experimental bits (or

EXP or pipe mode) carries out this disposition process and the packet is marked with a Differentiated Services Code Point (DSCP) or precedence value (also called DSCP or Precedence-based classification).

Usually, QoS traffic supports DSCP and precedence-based classifications only when there is no MPLS label in the packet. Using the ingress short-pipe feature, however, you can classify a packet that contains one MPLS label using the type-of-service (ToS) field of the IPv4 or IPv6 header. This classification method is called ingress short-pipe. To classify an IP packet this way, you must:

1. Create a child class map.
2. Specify a ToS value in the child class map.
3. Attach the child class map to a parent class map.
4. Create a policy map containing the parent class map.
5. Set any ingress action such as traffic class or QoS group. From Release 7.1.1 onwards, you can also set ingress action DSCP (or precedence value).

With the ingress short-pipe feature, you get an increased visibility into traffic packets. Plus, the feature also removes the limitation of classifying MPLS packets that come into IPv4 or IPv6 networks.

Restrictions and Other Important Points

Ensure that you read these points before you configure the ingress short-pipe feature.

- This feature isn't supported on:
 - NC57-24DD
 - NC57-18DD-SE
 - NC57-36H-SE
 - NC57-36H6D-S
 - NC57-MOD-S
 - NCS-57B1-6D24-SYS
 - NCS-57B1-5DSE-SYS
 - NCS-57C3-MOD-SYS
 - NCS-57D2-18DD-SYS
- This feature works only when there is one MPLS header in the traffic packet. If there are two or more MPLS headers, the ingress-short pipe feature fails. For example, in case of Explicit Null where there are two labels at the disposition, this feature will not work.
- You can carry out ingress classification using either the MPLS experimental bits (or EXP or pipe mode) classification OR the DSCP/precedence (or short-pipe) classification. Ensure that you do not mix the classification methods, else it may result in an unknown behavior, and the classification may not work at all.
- This feature is supported only on L3VPN, and not supported on L2VPN.

- This feature works for regular IPv4/IPv6 traffic, but will not work for IPv6 VPN Provider Edge over MPLS (6VPE).
- You can add only one child class map to a parent class map.
- This feature supports the invocation of short-pipe and legacy DSCP classification for the same parent class map.
- The child class map can contain only match precedence and match dscp commands.
- This feature is not supported in peering mode.

Configure Ingress Short-Pipe

This section details a sample configuration for the ingress short-pipe feature and another sample to configure classification for labeled and non-labeled packets under the same parent class.

Sample configuration to classify a packet that contains one MPLS label using the type-of-service (ToS) field of the IPv4 or IPv6 header (or the ingress short-pipe method):

```
class-map match-any in_pipe
  match mpls disposition class-map child_pipe
end-class-map
!
class-map match-any child_pipe
  match precedence 1
  match dscp ipv4 af11
  end-class-map
!
class-map match-any ingress-business-high
  match dscp af21 af22
end-class-map

class-map match-any ingress-business-low
  match dscp af11 af12
end-class-map

policy-map ingress-classifier
  class in_pipe
  set traffic-class 5
  set dscp af31
  class ingress-business-high
  set traffic-class 4
  class ingress-business-low
  set traffic-class 2
  class class-default
  set traffic-class 0
!
```



Note The **set dscp** option is available from Release 7.1.1 onwards.

You can configure classification for both labeled and non-labeled packets under the same parent class as in the following sample configuration. In this example, for MPLS labeled packets, DSCP configured under the child class is classified, while for non-labeled packets, DSCP/ToS configured in the **match dscp <value>** statement is classified.

DSCP value range is from 0 through 63. The range option is not supported. Up to 8 items per class are supported. Up to 64 **match dscp** values in total.

```
class-map match-any in_pipe
match mpls disposition class-map child_pipe (labeled case)
match dscp af11 (non-labeled case)
end-class-map
!
class-map match-any child_pipe
match precedence 1
match dscp ipv4 af11
end-class-map
!
class-map match-any ingress-business-high
match dscp af21 af22
end-class-map

class-map match-any ingress-business-low
match dscp af11 af12
end-class-map

policy-map ingress-classifier
class in_pipe
set traffic-class 5

class ingress-business-high
set traffic-class 4
class ingress-business-low
set traffic-class 2
class class-default
set traffic-class 0
!
```

Associated Commands

- **match mpls disposition class-map**

Selective Egress Policy-Based Queue Mapping

Table 18: Feature History Table

Feature Name	Release Information	Feature Description
Selective Egress Policy-Based Queue Mapping on NCS-57C3-MOD-SYS Routers and NC57-18DD-SE Line Cards	Release 24.1.1	<p>Introduced in this release on: NCS 5700 fixed port routers (select variants only*), NCS 5700 line cards [Mode: Compatibility; Native] (select variants only*)</p> <p>Based on specific customer service level agreements (SLAs), you can prioritize network traffic types by grouping egress traffic classes into priority queues.</p> <p>*This feature is supported on:</p> <ul style="list-style-type: none"> • NCS-57C3-MOD-SYS routers • NC57-18DD-SE line cards

With selective egress policy-based queue mapping, you can combine traffic class (TC) maps in various permutations at the egress.



Note Modular chassis do not support this feature.

The primary aim of introducing the egress TC (traffic class) mapping is to classify the traffic in the ingress using a single policy and place the classified traffic into queues, by assigning the traffic classes. At the egress, you can support different groupings of TCs.

Based on different Service Level Agreements (SLAs) that each customer has signed up for, you can group some TCs into priority queues for real time (RT) traffic, other TCs into guaranteed bandwidth (BW) traffic, and the rest into best effort (BE) traffic delivery.

Let us consider an example where three customers have purchased these services, based on their requirements:

- Customer A - Requires RT traffic, reserved BW traffic and BE traffic delivery.
- Customer B – Requires reserved BW traffic and BE traffic delivery.
- Customer C – Needs only BE traffic delivery.

Using the selective egress policy-based queue mapping, you can create three profiles this way:

- Customer A – Priority queue RT traffic (TC1), Guaranteed BW traffic (TC3), Best effort traffic (TC0, TC5)
- Customer B – Guaranteed BW traffic (TC1), Best effort traffic (TC0, TC3, TC5)
- Customer C - Best effort traffic (TC0, TC1, TC3, TC5)

Using the egress TC-mapping, you can create three different profiles that you can use for each customer based on their SLAs with the provider.

Figure 1: Selective Egress Policy-Based Queue Mapping Helps Create Customer Profiles Based on Their SLAs

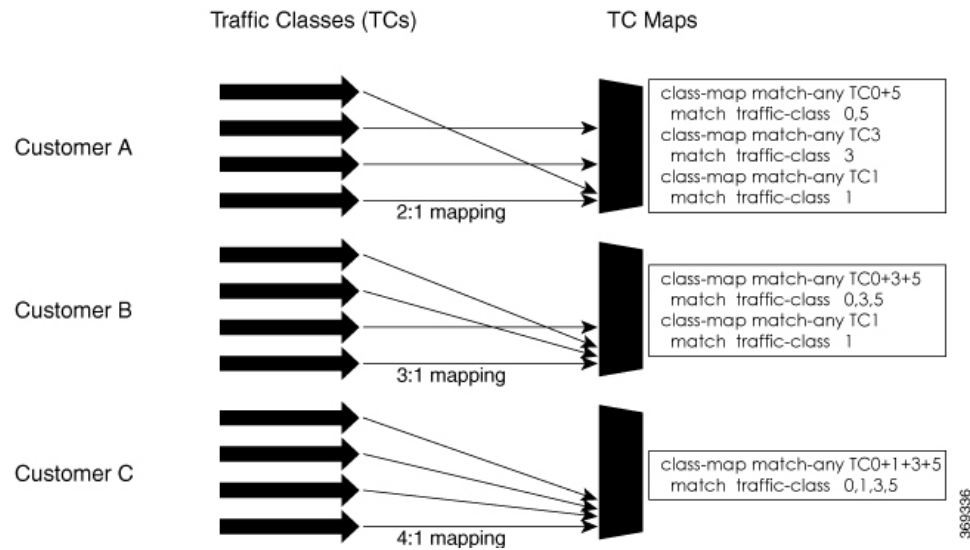

Restrictions and Other Important Points

- Ensure that you read these points before you configure the selective egress policy-based queue-mapping feature.
 - There can be only one TC (Traffic Class) mapped class to a PM (Policy Map).
 - You cannot use a TC that you used in a mapped class, in a non-mapped class under the same PM.
 - You can have a maximum of three unique TC mapped PMs or profiles per platform.
 - Every TC mapped class must include **traffic-class 0** in the range values.
 - The TC-mapping range is from 0 through 5.
 - When a TC-mapped class is present in a PM, the class default becomes a dummy class. This means that the class default statistics and QoS values are not applicable.
 - All the class default limitations apply to the TC-mapped class; for example, you cannot configure **priority** command under the TC mapped class.



Note A TC-mapped PM or profile is a PM that contains a TC-mapped class.

Example of a TC-mapped class:

```
match traffic-class 0 1 2 3
```

Example of a TC non-mapped class:

```
match traffic-class 1
```

- Support information
 - From Release 24.1.1, this feature is also supported on NCS-57C3-MOD-SYS routers and NC57-18DD-SE line cards.

Configure Selective Egress Policy-Based Queue Mapping

This section details a sample configuration for the selective egress policy-based queue-mapping feature and a use case to show how this feature works.

Sample configuration

```
class-map match-any <name>
  match traffic-class <value>
commit

policy-map tc_pmap
  class tc035
    shape average percent 1
  !
  class class-default
  !
end-policy-map
!
class-map match-any tc035
match traffic-class 0 3 5
end-class-map
!
```

Verification

Run the **show qos interface** and **show policy-map interface** commands.

When TC mapping class is present in a policy map, the class default does not have any values calculated.

show qos interface bundle-Ether 44 output sample

```
NOTE:- Configured values are displayed within parentheses
NPU Id:                                0
Total number of classes:                3
Interface Bandwidth:                    100000000 kbps
Policy Name:                             tc_pmap
Accounting Type:                         Layer1 (Include Layer 1 encapsulation and above)
-----
Level1 Class                            = tc1

Level1 Class                             = tc035

Level1 Class                             = class-default

Interface HundredGigE0/0/0/30 Ifh 0xf000208 (Member) -- output policy
NPU Id:                                0
Total number of classes:                3
Interface Bandwidth:                    100000000 kbps
Policy Name:                             tc_pmap
VOQ Base:                               1264
Accounting Type:                         Layer1 (Include Layer 1 encapsulation and above)
-----
Level1 Class                            = tc1
Egressq Queue ID                        = 1265 (LP queue)
```

```

Queue Max. BW.                = 10063882 kbps (10 %)
Queue Min. BW.                = 0 kbps (default)
Inverse Weight / Weight       = 1 / (BWR not configured)
Guaranteed service rate       = 10000000 kbps
TailDrop Threshold            = 12517376 bytes / 10 ms (default)
WRED not configured for this class

Level1 Class                   = tc035
Egressq Queue ID               = 1264 (LP queue)
Queue Max. BW.                 = 1011732 kbps (1 %)
Queue Min. BW.                 = 0 kbps (default)
Inverse Weight / Weight       = 1 / (BWR not configured)
Guaranteed service rate       = 1000000 kbps
TailDrop Threshold            = 1253376 bytes / 10 ms (default)
WRED not configured for this class

Level1 Class                   = class-default
Queue Max. BW.                 = no max (default)
Queue Min. BW.                 = 0 kbps (default)
Inverse Weight / Weight       = 0 / (BWR not configured)

```

show policy-map interface bundle-Ether 44 output sample

Bundle-Ether44 output: tc_pmap

```

Class tc1
  Classification statistics      (packets/bytes)      (rate - kbps)
  Matched                      : 429444/53823648      0
  Transmitted                   : 429444/53823648      0
  Total Dropped                 : 0/0                    0
  Queueing statistics
  Queue ID                     : None (Bundle)
  Taildropped(packets/bytes)    : 0/0
Class tc035
  Classification statistics      (packets/bytes)      (rate - kbps)
  Matched                      : 1288331/161470820    0
  Transmitted                   : 1288331/161470820    0
  Total Dropped                 : 0/0                    0
  Queueing statistics
  Queue ID                     : None (Bundle)
  Taildropped(packets/bytes)    : 0/0
Class class-default
  Classification statistics      (packets/bytes)      (rate - kbps)
  Matched                      : 0/0                    0
  Transmitted                   : 0/0                    0
  Total Dropped                 : 0/0                    0
  Queueing statistics
  Queue ID                     : None (Bundle)
  Taildropped(packets/bytes)    : 0/0
Policy Bag Stats time: 1557216940000 [Local Time: 05/07/19 08:15:40.000]
RP/0/RP0/CPU0:BB1#

```

Use Case

With the ingress traffic matching the same match criteria, you can group the egress traffic up to three unique TC mapped profiles. Using this feature, you can provide differentiated services to customers based on the SLAs they have signed up for.

In the example that follows, the ingress policy-map sets the ingress match criteria for the traffic class from 0 through 5. Based on the SLAs, you can group the TC values at the egress PM to deliver differentiated services.

After you group the TC values, you can apply specific egress actions under that class.

Ingress match:

```

class EXP1
  set traffic-class 1
!
class EXP2
  set traffic-class 2
!
class EXP3
  set traffic-class 3
!
class EXP4
  set traffic-class 4
!
class EXP5
  set traffic-class 5
!
class class-default
!
end-policy-map
!

```

Egress match:**Sample TC mapped class for policy-map PM1**

```

class-map match-any TC2:1
match traffic-class 0 1
end-class-map

```

Sample TC mapped class for policy-map PM2

```

class-map match-any TC3:1
match traffic-class 0 1 2
end-class-map

```

Sample TC mapped class for policy-map PM3

```

class-map match-any TC6:1
match traffic-class 0 1 2 3 4 5
end-class-map

```

Configuring QoS Groups with an ACL

You can create QoS groups and configure ACLs to classify traffic into the groups based on a specified match condition. In this example, we match by the QoS group value (0-511).

Supported ACL Types

Your router supports the following ACL types.



Note If you configure QoS group with an unsupported ACL type, the system doesn't display any error message.

ACL Type	Example
IPv4 DSCP	permit ipv4 any any dscp af43
UDP DSCP	permit udp any any dscp af43

ACL Type	Example
UDP Fragments IPv4	udp any any fragments - IPv4
UDP Fragments IPv6	udp any any fragments - IPv6
TCP Fragments IPv4	tcp any any fragments - IPv4
TCP Fragments IPv6	tcp any any fragments - IPv6
IPV4 DSCP Fragments	permit ipv4 any any dscp af43 fragments
UDP DSCP Fragments	permit udp any any dscp af43 fragments
UDP Host Fragments	permit udp host <sip> host <dip> fragments
TCP Host Fragments	permit tcp host <sip> host <dip> dscp af43 fragments
TCP DSCP	permit tcp <source network > <destination network> dscp af43
TCP Port based	permit tcp any any eq <port>
UDP Port based	permit udp any any eq <port>
TCP Flags	permit tcp host <sip> host <dip> established fin psh syn urg

Restrictions

- ACLs with fragment match are supported on systems with only NC57 line cards, also referred to as native mode.
- IPv6 ACLs with fragment match are supported only in **short** and **short-l2-qos** mode.

Prerequisites

Before you can configure QoS groups with an ACL, the QoS peering profile must be enabled on the router or the line card. After enabling QoS peering, the router or line card must be reloaded, as shown in the following configuration.



Note If you enable QoS peering, the Source-based RTBH (S-RTBH) feature will not be supported due to hardware limitations related to copy engine availability.

Enabling QoS Peering Profile on the Router

Enter the global configuration mode and enable the QoS peering profile for the router as shown:

```
RP/0/RP0/CPU0:router(config)# hw-module profile qos ingress-model peering
RP/0/RP0/CPU0:router(config)# exit
RP/0/RP0/CPU0:router# reload
```

Enabling QoS Peering Profile on the Line Card

Enter the global configuration mode and enable the QoS peering profile for the line card as shown:

```
RP/0/RP0/CPU0:router(config)# hw-module profile qos ingress-model peering location 0/0/CPU0
RP/0/RP0/CPU0:router(config)# exit
RP/0/RP0/CPU0:router# reload location 0/0/CPU0
```

Configuration

Use the following set of configuration statements to configure an ACL with QoS groups.

```
/*
  Enter the global configuration mode, and configure an ACL with the required QoS groups.
*/
RP/0/RP0/CPU0:router# configure
RP/0/RP0/CPU0:router(config)# ipv4 access-list qos-acl
RP/0/RP0/CPU0:router(config-ipv4-acl)# 10 permit ipv4 host 5.0.0.1 any set qos-group 1
RP/0/RP0/CPU0:router(config-ipv4-acl)# 11 permit ipv4 host 6.0.0.1 any set qos-group 2
RP/0/RP0/CPU0:router(config-ipv4-acl)# 12 permit ipv4 host 7.0.0.1 any set qos-group 3
RP/0/RP0/CPU0:router(config-ipv4-acl)# 13 deny ipv4 any any

/* Create a policy map with the required classes.
In this example, we also create a default class for traffic that does not belong to any of
the specified
classes. */
RP/0/RP0/CPU0:router(config)# policy-map qos-acl-map
RP/0/RP0/CPU0:router(config-pmap)# class qos1
RP/0/RP0/CPU0:router(config-pmap-c)# set dscp af43
RP/0/RP0/CPU0:router(config-pmap-c)# set traffic-class 2
RP/0/RP0/CPU0:router(config-pmap-c)# exit

RP/0/RP0/CPU0:router(config-pmap)# class qos2
RP/0/RP0/CPU0:router(config-pmap-c)# set precedence critical
RP/0/RP0/CPU0:router(config-pmap-c)# set traffic-class 7
RP/0/RP0/CPU0:router(config-pmap-c)# exit

RP/0/RP0/CPU0:router(config-pmap)# class qos3
RP/0/RP0/CPU0:router(config-pmap-c)# set precedence 2
RP/0/RP0/CPU0:router(config-pmap-c)# set traffic-class 2
RP/0/RP0/CPU0:router(config-pmap-c)# exit

RP/0/RP0/CPU0:router(config-pmap)# class qos4
RP/0/RP0/CPU0:router(config-pmap-c)# set traffic-class 4
RP/0/RP0/CPU0:router(config-pmap-c)# set dscp cs4
RP/0/RP0/CPU0:router(config-pmap-c)# exit

RP/0/RP0/CPU0:router(config-pmap)# class class-default
RP/0/RP0/CPU0:router(config-pmap-c)# police rate percent 20
RP/0/RP0/CPU0:router(config-pmap-c-police)# exit

/* Create the class maps for specifying the match conditions. */
RP/0/RP0/CPU0:router(config)# class-map match-any qos1
RP/0/RP0/CPU0:router(config-cmap)# match qos-group 1
RP/0/RP0/CPU0:router(config-cmap)# end-class-map

RP/0/RP0/CPU0:router(config)# class-map match-any qos2
RP/0/RP0/CPU0:router(config-cmap)# match qos-group 2
RP/0/RP0/CPU0:router(config-cmap)# end-class-map

RP/0/RP0/CPU0:router(config)# class-map match-any qos3
RP/0/RP0/CPU0:router(config-cmap)# match qos-group 3
```

```

RP/0/RP0/CPU0:router(config-cmap)# end-class-map

RP/0/RP0/CPU0:router(config)# class-map match-any qos4
RP/0/RP0/CPU0:router(config-cmap)# match qos-group 4
RP/0/RP0/CPU0:router(config-cmap)# end-class-map

/* Apply the access list and the QoS map to the Gigabit interface, and commit your
configuration. */
RP/0/RP0/CPU0:router(config)# interface TenGigE0/0/0/1
RP/0/RP0/CPU0:router(config-if)# ipv4 address 12.0.0.1/24
RP/0/RP0/CPU0:router(config-if)# no shut
RP/0/RP0/CPU0:router(config-if)# service-policy input qos-acl-map
RP/0/RP0/CPU0:router(config-if)# ipv4 access-group qos-acl ingress compress level 3

RP/0/RP0/CPU0:router(config-if)# commit
Tue Mar 28 10:23:34.106 IST

RP/0/0/CPU0:Mar 28 10:37:48.570 : ifmgr[397]: %PKT_INFRA-LINK-3-UPDOWN : Interface
TenGigE0/0/0/1, changed state to Down
RP/0/0/CPU0:Mar 28 10:37:48.608 : ifmgr[397]: %PKT_INFRA-LINK-3-UPDOWN : Interface
TenGigE0/0/0/1, changed state to Up

RP/0/RP0/CPU0:router(config-if)# exit

```

Running Configuration

Confirm your configuration.

```

RP/0/RP0/CPU0:router(config)# show run
Tue Mar 28 10:37:55.737 IST

Building configuration...
!! IOS XR Configuration 0.0.0

ipv4 access-list qos-acl
10 permit ipv4 host 5.0.1.1 any set qos-group 1
11 permit ipv4 host 6.0.1.1 any set qos-group 2
12 permit ipv4 host 7.0.1.1 any set qos-group 3
13 deny ipv4 any any

class-map match-any qos1
match qos-group 1
end-class-map
!
class-map match-any qos2
match qos-group 2
end-class-map
!
class-map match-any qos3
match qos-group 3
end-class-map
!
class-map match-any qos4
match qos-group 4
end-class-map
!

policy-map qos-acl-map
class qos1
set dscp af43
set traffic-class 2

```

```

!
class qos2
  set precedence critical
  set traffic-class 7
!
class qos3
  set precedence 2
  set traffic-class 2
!
class qos4
  set traffic-class 4
  set dscp cs4
!
class class-default
  police rate percent 20
!
!
end-policy-map
!

interface TenGigE0/0/0/1
  service-policy input qos-acl-map
  ipv4 address 12.0.0.1 255.255.255.0
  ipv4 access-group qos-acl ingress compress level 3
!

```

You have successfully configured an ACL with QoS groups.

Configuring an ACL with Fragment Match

Table 19: Feature History Table

Feature Name	Release Information	Feature Description
Additional Routers Supported for ACL with Fragment Match	Release 7.9.1	<p>Introduced in this release on NCS 5500 fixed port routers, NCS 5700 fixed port routers, and NCS 5500 modular routers.</p> <p>You can prevent malicious users from staging denial of service (DoS) attacks for non-initial IP by configuring an ACL with fragment match and specifying QoS match actions to rate-limit non-initial fragments for IPv4 traffic.</p>

Usually, IP ACLs process non-fragmented packets and the first fragments of a packet using permit and deny actions. These packets may have Layer 3 and 4 information that the ACLs match for a permit or deny action. By default, however, ACLs permit noninitial fragments. This could lead to potential security issues with users with malicious intent using the noninitial fragments to launch denial of service (DoS) attacks.

With this feature, you can now to set QoS policies for noninitial fragment packets, thus having more granular control over noninitial IP fragments of a packet. Noninitial IP fragments have the fragment offset value

non-zero. To know more about fragments, see the *IP Addresses and Services Configuration Guide for Cisco NCS 5500 Series Routers*.

Restrictions and Guidelines

The following restrictions and guidelines apply while configuring an ACL with fragment match.

- Until Cisco IOS XR Release 7.8.1, this feature is supported on systems with NC57 line cards running in native mode. You can configure IPv4 and IPv6 ACLs with fragment match on these systems. (See [Configuring an ACL with Fragment Match, on page 75](#).)
- From Cisco IOS XR Release 7.9.1 onwards, this feature is supported on all Cisco NCS 5700 Series Routers and on NCS 5500 Series Routers. You can configure only IPv4 ACLs with fragment match on these systems. (See [Configuring an ACL with Fragment Match, on page 75](#).)
- To enable IPv6 fragment classification support, configure **hw-module profile qos ipv6 short-l2qos-enable** or **hw-module profile qos ipv6 short**.
- IPv6 fragmentation is supported with only one Extension Header (EH).

Configuring an ACL with Fragment Match

For IPv4 and IPv6 ACLs

To configure an ACL with fragment match, you must:

1. Create IPv4 and IPv6 ACLs with fragment match.



Note To enable IPv6 fragment classification support, configure **hw-module profile qos ipv6 short-l2qos-enable** or **hw-module profile qos ipv6 short**.

2. Create two class maps, one for IPv4 and IPv6, and attach the respective ACLs to the class maps.
3. Create a policy map with these two class maps and set action.



Note You can configure IPv4 and IPv6 ACLs with fragment match only on systems with NC57 line cards running in native mode.

```
Router(config)#ipv4 access-list v4_ace
Router(config-ipv4-acl)#permit ipv4 any any fragments
Router(config-ipv4-acl)#exit
Router(config)#
Router(config)#ipv6 access-list v6_ace
Router(config-ipv6-acl)#permit ipv6 any any fragments
Router(config-ipv6-acl)#exit
Router(config)#
Router(config)#class-map match-any v4_class
Router(config-cmap)#match access-group ipv4 v4_ace
Router(config-cmap)#exit
Router(config)#
```

```

Router(config)#class-map match-any v6_class
Router(config-cmap)#match access-group ipv6 v6_ace
Router(config-cmap)#exit
Router(config)#policy-map frag_policy
Router(config-pmap)#class v4_class
Router(config-pmap-c)#set traffic-class 3
Router(config-pmap-c)#police rate 100 mbps
Router(config-pmap-c-police)#exit
Router(config-pmap-c)#
Router(config-pmap-c)#class v6_class
Router(config-pmap-c)#police rate 150 mbps peak-rate 200 mbps
Router(config-pmap-c-police)#exit
Router(config-pmap-c)#exit
Router(config-pmap)#exit

```

Running Configuration

```

ipv4 access-list v4_ace
 permit ipv4 any any fragments
 exit
!
ipv6 access-list v6_ace
 permit ipv6 any any fragments
 exit
!
class-map match-any v4_class
 match access-group ipv4 v4_ace
 exit
!
class-map match-any v6_class
 match access-group ipv6 v6_ace
 exit

policy-map frag_policy
 class v4_class
  set traffic-class 3
  police rate 100 mbps
  exit
!
 class v6_class
  police rate 150 mbps peak-rate 200 mbps

```

Verification

Run the **show policy-map pmap-name frag_policy detail** command to confirm the ACL fragment matches and the **show qos int hundredGigE 0/5/0/2 input** command to confirm the policer details.

```

Router#show policy-map pmap-name frag_policy detail
ipv4 access-list v4_ace
10 permit ipv4 any any fragments

ipv6 access-list v6_ace
10 permit ipv6 any any fragments

class-map match-any v4_class
match access-group ipv4 v4_ace
end-class-map
!
class-map match-any v6_class
match access-group ipv6 v6_ace
end-class-map
!
policy-map frag_policy

```

```

class v4_class
  set traffic-class 3
  police rate 100 mbps
  !
!
class v6_class
  police rate 150 mbps peak-rate 200 mbps
  !
!
class class-default
!
end-policy-map
!

Router#show qos int hundredGigE 0/5/0/2 input
NOTE:- Configured values are displayed within parentheses
Interface HundredGigE0/5/0/2 ifh 0xa000088 -- input policy
NPU Id:                                0
Total number of classes:                3
Interface Bandwidth:                    100000000 kbps
Policy Name:                            frag_policy
SPI Id:                                 0x0
Accounting Type:                         Layer2 (Include Layer 2 encapsulation and above)
-----
Level1 Class                            = v4_class
New traffic class                        = 3

Policer Bucket ID                       = 0x12
Policer Stats Handle                    = 0x0
Policer committed rate                 = 99609 kbps (100 mbits/sec)
Policer conform burst                   = 124672 bytes (default)

Level1 Class                            = v6_class

Policer Bucket ID                       = 0x11
Policer Stats Handle                    = 0x0
Policer committed rate                 = 150390 kbps (150 mbits/sec)
Policer peak rate                     = 200195 kbps (200 mbits/sec)
Policer conform burst                   = 186624 bytes (default)
Policer exceed burst                    = 436096 bytes (default)

Level1 Class                            = class-default

Default Policer Bucket ID               = 0x10
Default Policer Stats Handle            = 0x0
Policer not configured for this class

```

For IPv4 ACLs

To configure an ACL with fragment match, you must:

1. Create an IPv4 ACL with fragment match.
2. Create a class map for IPv4 and attach the ACL to the class map.
3. Create a policy map with the class map and set action.



Note You can configure IPv4 ACLs with fragment match on Cisco NCS 5700 Series Routers and on NCS 5500 Series Routers with line cards other than NC57 line cards.

```

Router(config)#ipv4 access-list v4_ace
Router(config-ipv4-acl)#permit ipv4 any any fragments
Router(config-ipv4-acl)#exit
Router(config)#
Router(config)#class-map match-any v4_class
Router(config-cmap)#match access-group ipv4 v4_ace
Router(config-cmap)#exit
Router(config)#
Router(config)#policy-map frag_policy
Router(config-pmap)#class v4_class
Router(config-pmap-c)#set traffic-class 3
Router(config-pmap-c)#police rate 100 mbps
Router(config-pmap-c-police)#exit
Router(config-pmap-c)#exit
Router(config-pmap)#exit

```

Running Configuration

```

ipv4 access-list v4_ace
  permit ipv4 any any fragments
  exit

!
class-map match-any v4_class
  match access-group ipv4 v4_ace
  exit
!

policy-map frag_policy
  class v4_class
    set traffic-class 3
    police rate 100 mbps
  exit
!

```

Verification

Run the **show policy-map pmap-name frag_policy detail** command to confirm the ACL fragment matches and the **show qos int hundredGigE 0/5/0/2 input** command to confirm the policer details.

```

Router#show policy-map pmap-name frag_policy detail
ipv4 access-list v4_ace
10 permit ipv4 any any fragments

class-map match-any v4_class
match access-group ipv4 v4_ace
end-class-map
!
!
policy-map frag_policy
class v4_class
  set traffic-class 3
  police rate 100 mbps
  !
!
class class-default
!
end-policy-map
!

Router#show qos int hundredGigE 0/5/0/2 input

```

```

NOTE:- Configured values are displayed within parentheses
Interface HundredGigE0/5/0/2 ifh 0xa000088 -- input policy
NPU Id:                                0
Total number of classes:                3
Interface Bandwidth:                    100000000 kbps
Policy Name:                            frag_policy
SPI Id:                                 0x0
Accounting Type:                         Layer2 (Include Layer 2 encapsulation and above)
-----
Levell Class                            = v4_class
New traffic class                        = 3

Policer Bucket ID                       = 0x12
Policer Stats Handle                    = 0x0
Policer committed rate                 = 99609 kbps (100 mbits/sec)
Policer conform burst                   = 124672 bytes (default)

Levell Class                            = class-default

Default Policer Bucket ID                = 0x10
Default Policer Stats Handle             = 0x0
Policer not configured for this class

```

Restrictions

Refer to the following table for Ingress QoS Scale limitation.

Table 20: Ingress QoS Scale Limitation

QoS Mode	Class-Map Size	Maximum number of Interfaces with Ingress QoS Applied	
		Per Core	Per NPU
Normal	4	1023	2046
Normal	8	511	1022
Normal	16	255	510
Normal	32	127	254
Enhanced	4	871	1742
Enhanced	8	435	870
Enhanced	16	217	434
Enhanced	32	108	216

This is a tabular classification of NCS 540 series platform and related models, detailing their maximum supported policers and class-map entries. When enhanced mode is enabled, the number of supported policers is reduced by half compared to the standard mode.



Note If you apply an ingress policy map to a bundle that has bundle members only from a single core of an NPU, the QoS resources are consumed on both cores of that NPU.

Example: For Default Configuration, which is Normal (2 counter mode) QoS Mode & 32 Class Map-Size, you can configure 191 interfaces with Ingress Policy per core.

Other restrictions to follow:

- In Egress QoS marking, you cannot change the traffic class or remark the performance measurement packets on Layer 3 with hardware timestamping.
- If you have a **set traffic class** statement explicitly configured in the ingress service policy, it's mandatory to have a corresponding **match traffic class** on egress for the traffic to be correctly matched and the stats to be accounted in **show policy-map interface <> output** command. To match the ingress traffic to the egress class-default, traffic class should be set to 0 on ingress.
- If you have a **set traffic class that is configured** in ingress service policy, and no corresponding **match traffic class** on egress, the traffic won't go to class default and the stats for this traffic flow won't be seen in **show policy-map interface <> output** command.
- If you don't have any **set traffic class** statement in ingress, then traffic will hit the default-class on egress.
- If you have a **set discard-class** statement configured in the ingress service policy, it's mandatory to have a corresponding **match discard-class** on egress for the traffic to be correctly matched and the stats to be accounted in **show policy-map interface <> output** command.
- If you have a **set discard-class** statement configured in the ingress service policy and don't have a corresponding **match discard-class** on egress, the traffic won't hit the class-default and the stats for this flow won't be accounted in **show policy-map interface <> output** command.
- The system doesn't support class-map size on peering mode.
- Even if you have an egress policy that has the drop action configured, the transmitted counter stats still shows an increment.
- Depending on the packet size, the traffic shaped value for low shaper rates, such as 10mbps, have greater deviation than 5% of tolerance from the shaper value. For higher shaper rates, the deviation is within the limit of 5% of tolerance from the shaper value for all packet sizes.
- If the shaper rate is less than 7 Mbps, the calculation of queue-limit is based on 10 ms of guaranteed service rate, and which leads to different queue-limit for each shaper value. This consumes the rate-profile for each queue-limit, and can also lead to a queue-limit of less than 1 MTU causing larger packets to drop.

Restrictions for Peering QoS Profile

- After enabling the QoS peering feature using the **hw-module profile qos ingress-model peering** command, you can set the Layer 2 class of service (CoS) or drop eligible indicator (DEI) values at the egress using the **set cos** or **set dei** commands, respectively. However, at the egress, ensure that you don't set the MPLS experimental imposition (EXP) values (using the **set mpls experimental imposition** command). Otherwise, when committing the policy map with these configurations at the egress, you will encounter an error. This error occurs because the internal fields required for egress EXP marking are not available with peering enabled.

- **explicit set discard-class** statement isn't supported.
- This feature is supported only on L3 interfaces and is limited to 1000 L3 interfaces per system.
- **set mpls exp topmost** statement isn't supported within QoS in peering mode.
- **access group** statement isn't supported.
- (Only in Release 6.2.x and Release 6.3.x) **set mpls exp imposition** statement isn't supported on ingress interface.
- 2-Level ingress policers isn't supported.
- (From Release 6.5.x) Egress H-QOS with peering profile support is enabled, but ingress H-QOS with peering profile isn't supported.
- Depending on the packet size, the traffic shaped value for low shaper rates, such as 10mbps, have greater deviation than 5% of tolerance from the shaper value. For higher shaper rates, the deviation is within the limit of 5% of tolerance from the shaper value for all packet sizes.
- (From Release 7.2.1) On NC57 line cards, QoS ingress peering profile isn't supported. This restriction is applicable for systems operating in compatibility mode and native mode.

Restrictions for QoS on BVI

- The system doesn't support the egress policy on Bridge-Group Virtual Interface (BVI), but BVI (CoS, DEI) marking is supported by applying the policy to its corresponding Layer 2 interface, which is part of the same bridge domain.
- If you apply L3 ingress QoS policy on L2 interface, which is a part of the same bridge-domain as BVI, the classification might not work if packets are destined to the BVI MAC address.
- If a QoS policy is attached to BVI, the policy is inherited by the L2 interfaces, which are part of the same bridge-domain. Hence, any other policy can't be applied on the L2 interfaces. Similarly, if a QoS policy is attached to any of the L2 interfaces, any QoS policy can't be applied on the BVI, which is part of the same bridge-domain.
- In the two-pass forwarding model for packets from Layer 2 to Layer 3 over BVI, where Layer 2 and Layer 3 forwarding are split across two paths and packet processing happens in two cycles, you can apply separate QoS policies for Layer 2 and BVI interfaces.

Restrictions for Egress Drop Action

- A maximum of 8 interfaces can have the drop action configured and a maximum of 8 classes in any single policy can have the drop action.
- A drop action in any particular class can't be combined with other actions.
- Drop action in a policy applied on the main interface isn't inherited onto sub-interfaces.
- Match condition for drop action PM can only be based on qos-group, discard class based match isn't supported.

Restrictions for egress QoS policy scale per line card NPU

Before applying egress QoS service policies, verify that the maximum supported number of egress policies per line card NPU core is not exceeded on the system. If the configured number of egress policies exceeds the supported limit for the platform, the configuration fails at commit time, and the router reports a VOQ resource exhaustion error.

Table 21: Supported egress QoS policy scale (per NPU core)

Platform	Maximum supported egress QoS policies (per NPU core)
NCS 5516	38
NCS 5508	77
NCS 5504	154

In-Place Policy Modification

The In-Place policy modification feature allows you to modify a QoS policy even when the QoS policy is attached to one or more interfaces. A modified policy is subjected to the same checks that a new policy is subject to when it is bound to an interface. If the policy-modification is successful, the modified policy takes effect on all the interfaces to which the policy is attached. However, if the policy modification fails on any one of the interfaces, an automatic rollback is initiated to ensure that the pre-modification policy is in effect on all the interfaces.

You can also modify any class map used in the policy map. The changes made to the class map take effect on all the interfaces to which the policy is attached.



Note

- The QoS statistics for the policy that is attached to an interface are lost (reset to 0) when the policy is modified.
- When a QoS policy attached to an interface is modified, there might not be any policy in effect on the interfaces in which the modified policy is used for a short period of time.
- The system does not support the show policy-map statistics for marking policies.
- An in-place modification of an ACL does not reset the policy-map statistics counter.



Note

- For QOS EXP-Egress marking applied on a Layer 3 interface on Cisco NCS550x and NCS55Ax routers, there is a limit of two unique policy-maps per NPU. This limit is three unique policy maps per NPU for routers that have the Cisco NC57 line cards installed. When the maximum limit for policy-maps is reached and you try to modify a policy-map which is shared between different interfaces, you may get an error.
- For QOS egress marking (CoS, DEI) applied on a Layer 2 interface, there is a limit of 13 unique policy-maps per NPU. When the maximum limit for policy-maps is reached and you try to modify a policy-map which is shared between different interfaces, you may get an error.

Verification

If unrecoverable errors occur during in-place policy modification, the policy is put into an inconsistent state on target interfaces. No new configuration is possible until the configuration session is unblocked. It is recommended to remove the policy from the interface, check the modified policy and then re-apply accordingly.

References for Modular QoS Service Packet Classification

Specification of the CoS for a Packet with IP Precedence

Use of IP precedence allows you to specify the CoS for a packet. You can create differentiated service by setting precedence levels on incoming traffic and using them in combination with the QoS queuing features. So that, each subsequent network element can provide service based on the determined policy. IP precedence is usually deployed as close to the edge of the network or administrative domain as possible. This allows the rest of the core or backbone to implement QoS based on precedence.

Figure 2: IPv4 Packet Type of Service Field

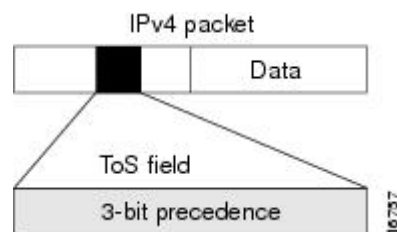

You can use the three precedence bits in the type-of-service (ToS) field of the IPv4 header for this purpose. Using the ToS bits, you can define up to eight classes of service. Other features configured throughout the network can then use these bits to determine how to treat the packet in regard to the ToS to grant it. These other QoS features can assign appropriate traffic-handling policies, including congestion management strategy and bandwidth allocation. For example, queuing features such as LLQ can use the IP precedence setting of the packet to prioritize traffic.

IP Precedence Bits Used to Classify Packets

Use the three IP precedence bits in the ToS field of the IP header to specify the CoS assignment for each packet. You can partition traffic into a maximum of eight classes and then use policy maps to define network policies in terms of congestion handling and bandwidth allocation for each class.

Each precedence corresponds to a name. IP precedence bit settings 6 and 7 are reserved for network control information, such as routing updates. These names are defined in RFC 791.

IP Precedence Value Settings

By default, the routers leave the IP precedence value untouched. This preserves the precedence value set in the header and allows all internal network devices to provide service based on the IP precedence setting. This policy follows the standard approach stipulating that network traffic should be sorted into various types of service at the edge of the network and that those types of service should be implemented in the core of the network. Routers in the core of the network can then use the precedence bits to determine the order of transmission, the likelihood of packet drop, and so on.

Because traffic coming into your network can have the precedence set by outside devices, we recommend that you reset the precedence for all traffic entering your network. By controlling IP precedence settings, you prohibit users that have already set the IP precedence from acquiring better service for their traffic simply by setting a high precedence for all of their packets.

The class-based unconditional packet marking and LLQ features can use the IP precedence bits.

IP Precedence Compared to IP DSCP Marking

If you need to mark packets in your network and all your devices support IP DSCP marking, use the IP DSCP marking to mark your packets because the IP DSCP markings provide more unconditional packet marking options. If marking by IP DSCP is undesirable, however, or if you are unsure if the devices in your network support IP DSCP values, use the IP precedence value to mark your packets. The IP precedence value is likely to be supported by all devices in the network.

You can set up to 8 different IP precedence markings and 64 different IP DSCP markings.

Conditional Marking of MPLS Experimental bits for L3VPN Traffic

The conditional marking of MPLS experimental bits is achieved for Layer 3 Virtual Private Network (L3VPN) traffic by applying a combination of ingress and egress policy-maps on the Provider Edge (PE) router. In the ingress policy-map, the qos-group or discard-class is set either based on the result of the policing action or implicitly. The egress policy-map matches on qos-group or discard-class and sets the mpls experiment bits to the corresponding value.

This feature is supported on both IPv4 and IPv6 traffic in the L3VPN network. Conditional marking can be used to mark the MPLS experimental bits differently for in-contract and out-of-contract packets. In-contract packets are the confirmed packets with the color green and discard-class set to 0. Out-of-contract packets are the packets which have exceeded the limit and have the color yellow and discard-class set to 1.

Conditional marking of MPLS experimental bits for L3VPN traffic is supported on both physical and bundle main interfaces as well as sub-interfaces.

Restrictions for Conditional Marking of MPLS Experimental bits on L3VPN

1. In the case of two PE routers connected back-to-back and the only label that the traffic between the routers have is the BGP label, then the explicit null label should be configured.
2. A maximum of three policy-maps which perform conditional marking of MPLS experimental bits can be configured per Network Processor Unit (NPU) of the Cisco NCS 5500 Series Routers.
3. In the ingress policy-map if qos-group is being set for the incoming traffic packets, then setting of dscp and mpls experimental bits will not work.
4. Both the ingress and egress policy-maps must be applied in order to attain the expected behaviour. If either one of them is not applied then it may lead to undefined behaviour.
5. If the egress policy-map does not match on qos-group or discard-class and set the mpls experiment bits to the required value, then the mpls experimental bits will be set to a value of zero, by default.

QoS DSCP Preservation

Table 22: Feature History Table

Feature Name	Release Information	Feature Description
QoS DSCP Preservation	Release 7.2.1	This feature is now also supported on routers that have the Cisco NC57 line cards installed and operate in the native mode.
QoS DSCP Preservation	Release 7.2.2	This feature is now also supported on routers that have the Cisco NC57 line cards installed and operate in the compatibility mode.

The DSCP value of the packet is preserved only for L3VPN networks when the packets are destined to the directly connected routes on the PE routers. To preserve the DSCP value for packets to destinations beyond the egress PE routers for L3VPN, you should use the **label mode per-vrf** command under the VRF at the PE routers. Similarly for MPLS networks, the default behaviour is uniform mode where the penultimate hop copies the MPLS EXP bit to IP DSCP and IP DSCP value is not preserved beyond the egress PE router. To preserve the IP DSCP value, you should use the **mpls ip-ttl-propagate disable** command at the penultimate hop.

DSCP value preservation is not supported on NC57-24DD and NC57-18DD-SE line cards for Cisco IOS XR Release 7.0.2.

QoS IP DSCP Preservation for SR-TE

Table 23: Feature History Table

Feature Name	Release Information	Feature Description
QoS IP DSCP Preservation for IPv6 SR-TE	Release 7.10.1	

Feature Name	Release Information	Feature Description
		<p>Introduced in this release on: NCS 5500 fixed port routers; NCS 5700 fixed port routers; NCS 5500 modular routers (NCS 5500 line cards; NCS 5700 line cards [Mode: Compatibility; Native])</p> <p>This release introduces the functionality to preserve IP DSCP markings for IPv6 SR-TE traffic and covers the following scenarios:</p> <ul style="list-style-type: none"> • For two or less than two topmost or imposition labels: when you set the MPLS experimental bits (EXP) values (also called Traffic Class values), the IP DSCP markings are now preserved by default in the ingress policies when the MPLS labels are pushed into the packet. • For more than three imposition labels: you must enable this functionality to preserve IP DSCP markings. <p>With preservation, traffic with IPv6 packets with DSCP marking for priority, flows as intended and there's no drop in traffic because of incorrect or missing labels.</p> <p>In previous releases, irrespective of the number of MPLS labels, when the EXP values were copied into the packet header during imposition, even the IP DSCP markings for IPv6 traffic were modified. This modification resulted in traffic drops at the next-hop routers in SR-TE tunnels.</p> <p>This feature introduces a new keyword, v6uc-enable, in the hw-module profile mpls-ext-dscp-preserve command.</p>

Feature Name	Release Information	Feature Description
QoS IP DSCP Preservation for SR-TE	Release 7.7.1	<p>In terms of preserving IP DSCP markings, this release covers two scenarios for SR-TE traffic:</p> <ul style="list-style-type: none"> • For two or less than two topmost or imposition labels: when you set the MPLS experimental bits (EXP) values (also called Traffic Class values), the IP DSCP markings are now preserved by default in the ingress policies when the MPLS labels are pushed into the packet. • For more than three imposition labels: you must enable this functionality to preserve IP DSCP markings. <p>With preservation, traffic with IP packets with DSCP marking for priority, flows as intended and there's no drop in traffic because of incorrect or missing labels.</p> <p>In previous releases, irrespective of the number of MPLS labels, when the EXP values were copied into the packet header during imposition, even the IP DSCP markings were modified. This modification resulted in traffic drops at the next-hop routers in SR-TE tunnels.</p> <p>This feature introduces the hw-module profile mpls-ext-dscp-preserve command.</p>

A typical ingress scenario for SR-TE traffic involves:

1. Specifying DSCP values as match criteria for a class map.
2. Identifying specific three-bit experimental bits (EXP) field values (also called Traffic Class or TC values, as per [RFC 5462](#)) in the topmost MPLS label as match criteria for the same class map.

When the MPLS labels are pushed (also called imposition) into the packet, the EXP values are copied into the EXP field in the packet header. At this stage, for SR-TE traffic, even the DSCP values that you set initially are modified, which could cause traffic drops at the next-hop router.

It is this behavior that the QoS DSCP preservation for SR-TE functionality mitigates. To enable this functionality, configure the **hw-module profile mpls-ext-dscp-preserve** command. This configuration ensures that the IP DSCP values are preserved for SR-TE traffic.



Note Ensure that you restart the router for the configuration to take effect.

Here's a quick look at what the QoS DSCP preservation for SR-TE functionality achieves.

Table 24: QoS DSCP Preservation for SR-TE and TI-LFA Scenarios

Scenario	What was happening in previous releases?	What's happening now?
SR-TE cases	Irrespective of the number of MPLS labels (1, 2, ... 12) for imposition, the push action modified IP DSCP values.	<ul style="list-style-type: none"> IP DSCP values are preserved by default for two or less than two MPLS labels. IP DSCP values are preserved for three or more labels only when you configure the hw-module profile mpls-ext-dscp-preserve command.
SR Topology-Independent Loop-Free Alternate (TI-LFA) cases	For three MPLS labels for imposition, the push action modified IP DSCP values.	Irrespective of the number of MPLS labels, IP DSCP values are preserved when you configure the hw-module profile mpls-ext-dscp-preserve command.

Guidelines and Limitations for QoS IP DSCP Preservation for SR-TE

- Disabling the propagation of IP Time-To-Live (TTL) to and from the MPLS header (using the **mpls ip-ttl-propagate** command) doesn't help preserve IP DSCP values for SR-TE traffic. This is because the IP TTL acts on the egress, while the DSCP preservation for SR-TE is for the ingress traffic.
- When you use the **on-demand steering** command to disable labeled services for SR-TE policies, your router supports 12 MPLS transport labels by default. With the QoS DSCP preservation for SR-TE functionality enabled, this default value changes to ten MPLS transport labels.
- By default, SR-TE (with steering services enabled) supports 2 service labels and 9 transport labels. This support changes to 2 service labels and 8 transport labels when you configure **hw-module profile mpls-ext-dscp-preserve**.
- This functionality doesn't work for SR-TE traffic associated with Binding Single-ID (BSID) policy paths. This is because packets with BSID labels get terminated, and new SR-TE labels get pushed, modifying the IP DSCP values. Thus, for BSID traffic (labeled traffic), disabling the propagation of IP TTL (using **mpls ip-ttl-propagate**) or configuring the **hw-module profile mpls-ext-dscp-preserve** command to enable QoS DSCP preservation for SR-TE doesn't help in IP DSCP preservation.

- This functionality isn't applicable for routers that have Cisco NC57 line cards installed and operating in native and compatibility modes. For these routers, DSCP preservation is by default, irrespective of the number of labels for both SR TI-LFA and SR-TE cases.
- The `hw-module profile sr-policy v6-null-label-autopush` and `hw-module profile mpls-ext-dscp-preserve` commands are mutually exclusive.

Configuration for QoS IP DSCP Preservation for SR-TE

Configuration Example

To configure QoS IP DSCP preservation for SR-TE:

1. Match the DSCP value for a class map. (See [match dscp](#) for command details.)

```
Router(config)#class-map
Router(config)#class-map match-any exp_policy
Router(config-cmap)#match dscp cs2
Router(config-cmap)#end-class-map
Router(config)#
```

2. Set the MPLS EXP value for the same map. (See [set mpls experimental](#) for command details.)

```
Router(config)#policy-map exp_policy
Router(config-pmap)#class exp_policy
Router(config-pmap-c)#set mpls experimental imposition 7
Router(config-pmap-c)#set traffic-class 7
Router(config-pmap-c)#commit
```

3. Apply the policy on the ingress interface.

```
Router(config)#interface TenGigE0/0/0/0
Router(config-if)#service-policy input exp_policy
Router(config-if)#ipv4 address 192.0.2.1 255.255.255.0
Router(config-if)#commit
```

4. Nexthop reachability for ingress traffic is through SR-TE Tunnels. To configure SR-TE policies, see *Configure SR-TE Policies* in the *Segment Routing Configuration Guide for Cisco NCS 5500 Series Routers*.
5. Configure the DSCP preservation for IPv4 or IPv6 SR-TE traffic and reload the chassis for the configuration to take effect.

```
Router#config
Router(config)#hw profile mpls-ext-dscp-preserve v4uc-enable
or
Router(config)#hw profile mpls-ext-dscp-preserve v6uc-enable
Router(config)#commit
Router(config)#exit
Router#reload location all
```

Running Configuration for IPv4 SR-TE Traffic

The following is the running configuration for DSCP preservation for IPv4 SR-TE traffic.

```
class-map
class-map match-any exp_policy
  match dscp cs2
end-class-map
!
```

```

policy-map
policy-map exp_policy
  class exp_policy
    set mpls experimental imposition 7
    set traffic-class 7
!

interface TenGigE0/0/0/0
service-policy input exp_policy
ipv4 address 192.0.2.1 255.255.255.0
!

hw profile mpls-ext-dscp-preserve v4uc-enable
!

```

Running Configuration for IPv6 SR-TE Traffic

The following is the running configuration for DSCP preservation for IPv6 SR-TE traffic.

```

Class-map
Router#show run class-map
Tue Apr 18 20:30:51.077 UTC
class-map match-any dscp-preserve-cm
match dscp ipv6 0
  end-class-map
!

Policy-map
Router#show run policy-map
Tue Apr 18 20:31:08.077 UTC
policy-map dscp-preserve-pm
class dscp-preserve-cm
  set dscp 3
  set mpls experimental imposition 4
!
class class-default
!
end-policy-map
!

Policy-map attached to ingress interface:

interface HundredGigE0/0/0/10
service-policy input dscp-preserve-pm
ipv4 address 103.1.1.1 255.255.255.248
ipv6 address 2002::6701:101/125
!

```

Verification for IPv4 SR-TE Traffic

Verify that you have successfully configured DSCP preservation for IPv4 SR-TE traffic

Run the command **show controller fia diagshell 0 "config" location 0/0/cpu0 | i dscp** and in the output, verify that **custom_feature_dscp_preserve_with_extend_label** equals 1. The value is 1 only when the **hw profile mpls-ext-dscp-preserve v4uc-enable** command takes effect after router reload.

```

Router#show controller fia diagshell 0 "config" location 0/0/cpu0 | inc dscp_preserve
  custom_feature_dscp_preserve_with_extend_label_v6=1

```

Verification for IPv6 SR-TE Traffic

Verify that you have successfully configured DSCP preservation for IPv6 SR-TE traffic

Run the command **show controller fia diagshell 0 "config" location 0/0/cpu0 | inc dscp_preserve** and in the output, verify that **custom_feature_dscp_preserve_with_extend_label_v6** equals 1. The value is 1 only when the **hw profile mpls-ext-dscp-preserve v6uc-enable** command takes effect after router reload.

```
show controllers fia diagshell 0 "config show" location 0/1/CPU0 | include "dscp_preserve"
Sat Jun 24 01:25:13.883 UTC
  custom_feature_dscp_preserve_with_extend_label_v6=1
  custom_feature_dscp_preserve_outlif_bits_mask=3
  custom_feature_dscp_preserve_with_extend_label=1
```

QoS DSCP Preservation for mLDP

Table 25: Feature History Table

Feature Name	Release Information	Feature Description
QoS DSCP Preservation for mLDP	Release 7.7.1	<p>In terms of preserving IP DSCP markings, when you set the MPLS experimental bits (EXP) values (also called Traffic Class values), the IP DSCP markings are now preserved by default in the ingress policies when the MPLS labels are pushed into the packet.</p> <p>Traffic with IP packets with DSCP marking for priority, flows as intended and there's no drop in traffic because of incorrect or missing labels.</p> <p>In previous releases, irrespective of the MPLS label, when the EXP values were copied into the packet header during disposition, even the IP DSCP markings were modified. This modification resulted in traffic drops at the last-hop routers.</p>

A typical ingress scenario for mLDP traffic involves:

1. Specifying DSCP values as match criteria for a class map.
2. Identifying specific three-bit experimental bits (EXP) field values (also called Traffic Class or TC values, as per [RFC 5462](#)) in the MPLS label as match criteria for the same class map.

For MPLS networks, the default behaviour is uniform mode, where the MPLS labels are popped (disposition) at the end of the mLDP tunnel, the EXP values in the popped label is copied to the IP DSCP field, which causes the DSCP values that you set initially get modified. This modification causes traffic drops at the last-hop router.

It is this behavior that the QoS DSCP preservation for mLDP functionality mitigates.

From Cisco IOS XR Release 7.7.1 onwards, the QoS DSCP preservation for mLDP functionality is enabled by default when you bring up an edge router with mLDP profile configuration. Earlier, to help preserve IP DSCP values for mLDP traffic, you could disable the propagation of IP Time-To-Live (TTL) to and from the MPLS header by using the [mpls ip-ttl-propagate disable](#) command.

For more information on mLDP configuration, see the *Multicast MLDP Profile 14 support on an Edge Router* section in *Multicast Configuration Guide for Cisco NCS 5500 Series Routers*.

Configuration for QoS IP DSCP Preservation for mLDP

Configuration Example

To configure QoS IP DSCP preservation for mLDP:

1. Match the DSCP value for a class map. (See [match dscp](#) for command details.)

```
Router(config)#class-map
Router(config)#class-map match-any exp_policy
Router(config-cmap)#match dscp cs2
Router(config-cmap)#end-class-map
Router(config)#
```

2. Set the MPLS EXP value for the same map. (See [set mpls experimental](#) for command details.)

```
Router(config)#policy-map exp_policy
Router(config-pmap)#class exp_policy
Router(config-pmap-c)#set mpls experimental imposition 7
Router(config-pmap-c)#class class-default
Router(config-pmap-c)#commit
```

3. Apply the policy on the ingress interface.

```
Router(config)#interface TenGigE0/0/0/0
Router(config-if)#service-policy input exp_policy
Router(config-if)#ipv4 address 192.0.2.1 255.255.255.0
Router(config-if)#commit
```

4. Next-hop reachability for ingress traffic is through mLDP Tunnels. To configure mLDP, see the *Multicast MLDP Profile 14 support on an Edge Router* section in *Multicast Configuration Guide for Cisco NCS 5500 Series Routers*.

Running Configuration

```
class-map
class-map match-any exp_policy
  match dscp cs2
end-class-map
!

policy-map
policy-map exp_policy
  class exp_policy
    set mpls experimental imposition 7
  class class-default
!

interface TenGigE0/0/0/0
service-policy input exp_policy
ipv4 address 192.0.2.1 255.255.255.0
```

```
!
```

Verification

Run the command **show policy-map interface** and in the output, verify that in the ingress interface the traffic arrive with EXP value as **exp 4** and DSCP value as **cs6**. At egress, the DSCP value remains same as **cs6**.

```
RP/0/RP0/CPU0:ios#sh policy-map interface te0/0/0/0 input
Thu Jan  6 23:42:36.039 UTC

TenGigE0/0/0/0 input: exp_policy

Class exp_policy
  Classification statistics          (packets/bytes)      (rate - kbps)
  Matched                          :          86601328/1108496984      821764
  Transmitted                       :          86601328/1108496984      821764
  Total Dropped                     :                   0/0              0
Class class-default
  Classification statistics          (packets/bytes)      (rate - kbps)
  Matched                          :           2347/300416              0
  Transmitted                       :           2347/300416              0
  Total Dropped                     :                   0/0              0
Policy Bag Stats time: 1641512538846 [Local Time: 01/06/22 23:42:18.846]
RP/0/RP0/CPU0:ios#
```

Verify the DSCP value of cs6 (represented as 6C) in the IPv6 traffic:

```
IPv6 traffic
68 2C 7B 84 58 4B 00 8A 96 0D 40 44 88 47 05 DC C9 3E 6C 00 00 00 00 46 3B 3F
00 77 00 00 00 00 00 00 00 00 00 00 00 00 09 FF 33 00 00 00 00 00 00 00 00 00 00
00 08 06 10 71 CF 38 A2 D3 70 49 78 69 61 60 00 00 00 10 11 12 13 E0 EC 18 77 00 2A 1A 1B
1C 1D 1E 1F 20 21 22 23 24 25 26 27 28 29 2A 2B 2C 2D 2E 2F 30 31 32 33 34 35 36 37 38 39
3A 3B 3C 3D 3E 3F 40 41 42 43 FB 2A
```

Policy-map for conditional marking of incoming IPv4 and IPv6 traffic

The incoming packets are classified based on the ingress policy-map and the following actions are done.

- Set qos-group
- Discard class or drop precedence is set implicitly or as a result of a policing action.
- Packets that violate the configured policer are dropped in the ingress processing itself.

Running Configuration:

```
policy-map ingress
class af11
  police rate percent 10 peak-rate percent 20
  !
  set qos-group 1
  !
class af22
  police rate percent 30 peak-rate percent 50
  !
  set qos-group 2
  !
class af32
  set qos-group 3
  police rate percent 30 peak-rate percent 60
  !
```

```

!
class class-default
!
end-policy-map
!

```

Policy-map for conditional marking of outgoing MPLS traffic

The IPv4 or IPv6 ingress packet undergoes MPLS encapsulation during the egress processing in the PE router which performs the label imposition. The MPLS experimental bits are marked on the basis of egress policy-map which performs the following actions:

- Match on qos-group or discard class or both
- Set the MPLS experimental bits based on the match criteria

Running Configuration:

```

policy-map egress
class qos1_disc0 # This class matches on qos-group 1 and discard-class 0
  set mpls experimental imposition 1
!
class qos1_disc1 # This class matches on qos-group 1 and discard-class 1
  set mpls experimental imposition 5
!
class qos2_disc0 # This class matches on qos-group 2 and discard-class 0
  set mpls experimental imposition 2
!
class qos2_disc1 # This class matches on qos-group 2 and discard-class 1
  set mpls experimental imposition 6
!
class qos3_disc0 # This class matches on qos-group 3 and discard-class 0
  set mpls experimental imposition 3
!
class qos3_disc1 # This class matches on qos-group 3 and discard-class 1
  set mpls experimental imposition 7
!
class class-default
!
end-policy-map
!

```

Conditional Marking of MPLS Experimental bits for L2VPN Traffic



Note This feature is not available on NC57-24DD and NC57-18DD-SE line cards for Cisco IOS XR Release 7.0.2.

Conditional marking of MPLS EXP bits is supported on Virtual Private Wire Service (VPWS), Virtual Private LAN Service (VPLS) and Ethernet Virtual Private Network (EVPN) traffic in the L2VPN network.

The conditional marking of MPLS experimental bits is achieved for Layer 2 Virtual Private Network (L2VPN) traffic by applying a combination of ingress and egress policy-maps on the Provider Edge (PE) router. In the ingress policy-map, the qos-group or discard-class is set either based on the result of the policing action or implicitly. The egress policy-map matches on qos-group or on a combination of qos-group and discard-class and sets the mpls experiment bits to the corresponding value.

Conditional marking can be used to mark the MPLS experimental bits differently for in-contract and out-of-contract packets. In-contract packets are the confirmed packets with the color green and discard-class set to 0. Out-of-contract packets are the packets which have exceeded the limit and have the color yellow and discard-class set to 1.

Conditional marking of MPLS experimental bits for L2VPN traffic is supported on both physical and bundle main interfaces as well as sub-interfaces.

Restrictions for Conditional Marking of MPLS Experimental bits on L2VPN

1. Conditional marking of MPLS EXP bits is not supported for broadcast, unknown unicast and multicast (BUM) traffic.
2. In the case of two PE routers connected back-to-back and the only label that the traffic between the routers have is the BGP label, then the explicit null label should be configured.
3. A maximum of two policy-maps which perform conditional marking of MPLS experimental bits can be configured per Network Processor Unit (NPU) of the Cisco NCS 5500 Series Routers. However, the same policy can be applied on multiple interfaces on the same NPU.
4. In the ingress policy-map if qos-group is being set for the incoming traffic packets, then setting of dscp and mpls experimental bits will not work.
5. Both the ingress and egress policy-maps must be applied in order to attain the expected behaviour. If either one of them is not applied then it may lead to undefined behaviour.
6. If the egress policy-map does not match on qos-group or discard-class and set the mpls experiment bits to the required value, then the mpls experimental bits will be set to a value of zero, by default.

Policy-map for conditional marking of incoming traffic

The incoming packets on the Power Edge router are classified based on the ingress policy-map and these actions are taken.

- Set qos-group
- Discard class or drop precedence is set implicitly or as a result of a policing action.
- Set traffic class
- Packets that violate the configured policer are dropped in the ingress processing itself.

Running Configuration:

```
class-map af11
  match cos 1
!

policy-map ingress
  class af11
    police rate percent 10 peak-rate percent 20
    !
    set qos-group 1
    set Traffic-class 3
  !
  class class-default
  !
```

```
end-policy-map
!
```

Policy-map for conditional marking of outgoing MPLS traffic

The ingress packet undergoes MPLS encapsulation during the egress processing in the PE router which performs the label imposition. The MPLS experimental bits are marked on the basis of egress policy-map which performs the following actions:

- Match on qos-group or discard class or both
- Set the MPLS experimental bits based on the match criteria

Running Configuration:

```
class-map match-all qos-group2_0
  match qos-group 2
  match discard-class 0

policy-map egress-marking
  class qos-group2_0 # This class matches on qos-group 2 and discard-class 0
    set mpls experimental imposition 1
  !
  class class-default
  !
end-policy-map
!
policy-map Egress-Queuing
  class Traffic-class3
    shape average 500 mbps
  !
  class class-default
  !
end-policy-map
!
```

Conditional Marking of MPLS Experimental Bits for EVPN-VPWS Single-Homing Services

Table 26: Feature History Table

Feature Name	Release Information	Feature Description
Conditional Marking of MPLS Experimental Bits for EVPN-VPWS Single-Homing Services	Release 7.3.1	<p>This feature enables you to differentiate traffic in the MPLS forwarding domain and manage traffic from ingress PE to egress PE based on the MPLS EXP bit of the MPLS header.</p> <p>This feature is supported only for EVPN-VPWS single-homing services, and not supported for EVPN-VPWS multi-homing services.</p>

The conditional marking of MPLS experimental bits is achieved for EVPN-VPWS single-homing services by applying a combination of ingress and egress policy-maps on the provider edge (PE) router. In the ingress

policy-map, the qos-group or discard-class is set either based on the result of the policing action or implicitly. The egress policy-map matches on qos-group or on a combination of qos-group and discard-class and sets the MPLS experiment bits to the corresponding value.

Conditional marking can be used to mark the MPLS experimental bits differently for in-contract and out-of-contract packets. In-contract packets are the confirmed packets with the color green and discard-class set to 0. Out-of-contract packets are the packets that have exceeded the limit and have the color yellow and discard-class set to 1.

Conditional marking of MPLS experimental bits for EVPN-VPWS single-homing services are supported on both physical and bundle main interfaces as well as sub-interfaces.

MPLS EXP Marking for EVPN Multi-Homed Services

Table 27: Feature History Table

Feature Name	Release Information	Feature Description
MPLS EXP Marking for EVPN Multi-Homed Services	Release 7.6.1	You can now differentiate traffic in the MPLS forwarding domain and manage traffic from ingress PE to egress PE based on the MPLS EXP bit of the MPLS header for EVPN multi-home scenarios.



Note This feature is not supported on routers that have the Cisco NC57 line cards installed and operate in the native mode or compatibility mode.

Configuration

- The ingress policing is applied on the UNI interface. It is with set qos-group and set traffic class.
- The marking policy is applied at the core facing NNI interface.
- MPLS EXP imposition is marked while packets egress from NNI Interface.

Running Configuration

```
interface TenGigE0/0/0/2.203 l2transport => This is UNI
encapsulation dot1q 203
service-policy input pol50-100

interface TenGigE0/0/0/10 =====> This is the core NNI
description *** CORE IF ***
cdp
service-policy input in_mpls
service-policy output eg_mark
ipv4 address 192.18.44.18 255.255.255.0
ipv6 address 2005:18:44::18/48
lldp
  enable
!
monitor-session test ethernet direction tx-only port-level
!
```

```

load-interval 30
!
l2vpn
xconnect group 203
  p2p 203
    interface TenGigE0/0/0/2.203
      neighbor evpn evi 1 service 203

policy-map pol150-100
class class-default
  set traffic-class 2
  set qos-group 4
  police rate 50 mbps peak-rate 100 mbps
!
!
end-policy-map
!

policy-map eg_mark
class qg4dc0
  set mpls experimental imposition 2
!
class qg4dc1
  set mpls experimental imposition 3
!
class class-default
!
end-policy-map
!
class-map match-all qg4dc0
match qos-group 4
match discard-class 0
end-class-map
!

class-map match-all qg4dc1
match qos-group 4
match discard-class 1
end-class-map

```

Verification

Verify that you have configured conditional marking of MPLS experimental bits for EVPN-VPWS single-homing services successfully.

```

Router#show qos int tenGigE 0/0/0/2.101 input
NOTE:- Configured values are displayed within parentheses
Interface TenGigE0/0/0/2.101 ifh 0x41da -- input policy
NPU Id: 0
Total number of classes: 1
Interface Bandwidth: 10000000 kbps
Policy Name: pol150-100
Accounting Type: Layer1 (Include Layer 1 encapsulation and above)
-----
Levell1 Class = class-default
New traffic class = 2
New qos group = 4

Policer Bucket ID = 0x18
Policer Stats Handle = 0x0
Policer committed rate = 49219 kbps (50 mbits/sec)
Policer peak rate = 98438 kbps (100 mbits/sec)
Policer conform burst = 62336 bytes (default)

```

```

Policer exceed burst                               = 187008 bytes (default)
-----

Router#show qos int tenGigE 0/0/0/10 output
Tue Sep 1 04:18:27.508 UTC
NOTE:- Configured values are displayed within parentheses
Interface TenGigE0/0/0/10 ifh 0xe0 -- output policy
NPU Id:                                           0
Total number of classes:                         3
Interface Bandwidth:                             10000000 kbps
Policy Name:                                     eg_mark
VOQ Base:                                        0
Accounting Type:                                 Layer1 (Include Layer 1 encapsulation and above)
-----

Level1 Class                                     = qg4dc0
New imposition exp                               = 2
Queue Max. BW.                                  = no max (default)
Queue Min. BW.                                  = 0 kbps (default)
Inverse Weight / Weight                         = 0 / (BWR not configured)

Level1 Class                                     = qg4dc1
New imposition exp                               = 3
Queue Max. BW.                                  = no max (default)
Queue Min. BW.                                  = 0 kbps (default)
Inverse Weight / Weight                         = 0 / (BWR not configured)

Level1 Class                                     = class-default
Queue Max. BW.                                  = no max (default)
Queue Min. BW.                                  = 0 kbps (default)
Inverse Weight / Weight                         = 0 / (BWR not configured)
-----

```

Classifying Packets Based On MPLS Experimental Bits in MPLS Over GRE

Table 28: Feature History Table

Feature Name	Release Information	Feature Description
Classifying Packets Based On MPLS Experimental Bits in MPLS Over GRE	Release 7.5.2 Release 7.3.4	<p>For MPLS over GRE scenarios that tunnel MPLS traffic over non-MPLS networks, you can now perform QoS classification for specific traffic or applications based on MPLS EXP bit field values in the MPLS header.</p> <p>In earlier releases, you could perform QoS classification only in the outer GRE IP header using DiffServ Code Point (DSCP) or IP precedence bits that helped you achieve the required line rate minus the granularity.</p> <p>This feature introduces the hw-module profile qos gre-exp-classification-enable command.</p>

You can now perform QoS classification based on the MPLS header that the GRE IP header encapsulates in a single-pass GRE scenario. This classification takes place on the MPLS labels (specifically the experimental bits or EXP) in the MPLS header after the GRE is decapsulated using Policy-Based Routing (PBR). Because the MPLS labels identify specific customer traffic and applications, the classification is more granular. As the traffic moves along the single-pass GRE, the POP tag removes the MPLS header, and the outgoing traffic with QoS classification has the inner IP header. (Also, see [Terms Used for Classifying Packets Based On MPLS Experimental Bits in MPLS Over GRE](#).)

To enable QoS classification on the inner MPLS header, run the command `hw-module profile qos gre-exp-classification-enable`.



Note Ensure that you reload the line card for this command to take effect. If you don't reload the line card, QoS classification will continue on the outer GRE IP header with DSCP or IP precedence marking.

To understand how this functionality works, see the figure **QoS Classification on Inner MPLS Header for MPLS over GRE**.

Figure 3: QoS Classification on Inner MPLS Header for MPLS over GRE

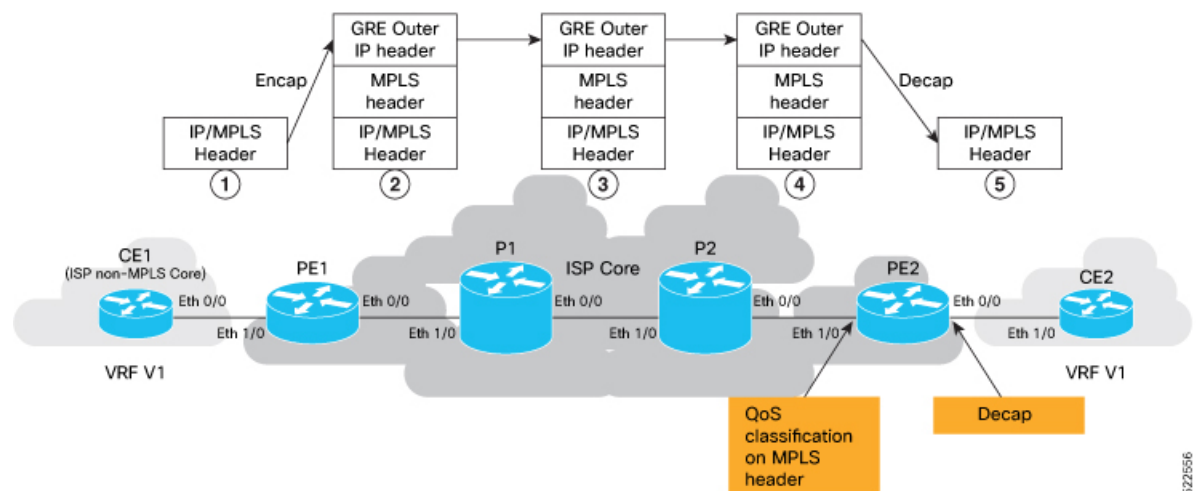

1. The MPLS packet approaches the beginning of the GRE tunnel. The GRE tunnel is configured across a non-MPLS network on the provider edge (PE) devices, PE1 and PE2, which are at either end of the tunnel.
2. GRE encapsulation is added at tunnel entry point.
3. The MPLS packet traverses the non-MPLS network, where only the outer IP header is parsed by routers.
4. When the packet reaches the ingress interface (Eth 1/0) on router PE2, QoS classification is performed based on MPLS EXP bits. Before the packet reaches the egress interface (Eth 0/0) of PE2, the outer GRE header is removed.
5. The packet with the MPLS header now travels toward its ultimate destination to CE2.

Behavioral Specifications

- This feature is supported only in scenarios where you enable GRE single-pass. (You configure the **tunnel mode gre ipv4 encap** command in GRE single-pass. See [Set Up and Configuration for QoS Classification on MPLS Header](#), on page 102.)
- To preserve the inner DSCP markings and IP Time-to-Live (TTL) values, you must disable the propagation of IP Time-to-Live (TTL) to and from the MPLS header for forwarded and local packets. See [mpls ip-ttl-propagate](#).

Restrictions

This feature isn't supported on routers that have Cisco NC57 line cards installed and operate in the native and compatibility mode.

Set Up and Configuration for QoS Classification on MPLS Header

This section describes the configuration details for QoS classification on the MPLS header in a single pass GRE tunnel per the Figure [QoS Classification on Inner MPLS Header for MPLS over GRE](#).

Configuration for PE1 (encap node) where you:

- enable GRE single-pass.
- assign the GRE tunnel source and destination addresses.
- assign IPv4 addresses for PE1 and PE2.

```
Router(config)#interface tunnel-ip_intf1
Router(config-if)#ipv4 address 203.0.113.1 255.255.255.252
Router(config-if)#tunnel mode gre ipv4 encap
Router(config-if)#tunnel source 13.1.1.1
Router(config-if)#tunnel destination 11.1.1.1
Router(config-if)#root
Router(config)#interface Eth 1/0
Router(config-if)#ipv4 address 209.165.201.1 255.255.255.224
Router(config-if)#exit
Router(config-if)#interface Eth 0/0
Router(config-if)#ipv4 address 198.51.100.1 255.255.255.0
Router(config-if)#commit
```

Configuration for intermediate hop router (P1) where you configure the forwarding addresses for packets.

```
Router(config)#interface Eth1/0
Router(config-if)#ipv4 address 198.51.100.2 255.255.255.0
Router(config-if)#root
Router(config)#
Router(config)#interface Eth0/0
Router(config-if)#ipv4 address 203.0.113.1 255.255.255.0
Router(config-if)#root
Router(config)#commit
```

Configuration for intermediate hop router (P2) where you configure the forwarding addresses for packets.

```
Router(config)#interface Eth1/0
Router(config-if)#ipv4 address 203.0.113.2 255.255.255.0
Router(config-if)#root
Router(config)#
Router(config)#interface Eth0/0
Router(config-if)#ipv4 address 192.0.2.1 255.255.255.0
```

```
Router(config-if)#root
Router(config)#commit
```

Configuration for PE2 (decap node) where you:

- disable TTL to preserve the IP header DSCP and TTL.
- configure **hw-module profile qos gre-exp-classification-enable**.



Note Ensure that you reload the line card for this command to take effect. If you don't reload the line card, QoS classification will continue on the outer GRE IP header with DSCP or IP precedence marking. We recommend that you use the **hw-module location all reload** command in Sysadmin VM.

- configure MPLS EXP bits, class-map, and the policy-map before decapsulation.

```
Router(config)#mpls ip-ttl-propagate disable
Router(config)# hw-module profile qos gre-exp-classification-enable
NOTE:To activate this profile, you must manually reload the chassis/all line cards
Router(config)#
#reload the device to get effect of qos gre-exp-classification
/*We recommend that you use the hw-module location all reload command in Sysadmin
VM*/
Router#admin
root connected from 192.0.108.4 using ssh on sysadmin-vm:0_RP0
sysadmin-vm:Router#hw-module location all reload
!

/*After reloading, configure MPLS exp bits, class-map, and the policy-map*/
Router(config)#class-map match-any exp1
Router(config-cmap)#match mpls experimental topmost 1
Router(config-cmap)#end-class-map
Router(config)#class-map match-any exp2
Router(config-cmap)#match mpls experimental topmost 2
Router(config-cmap)#end-class-map
Router(config)#class-map match-any cs1
Router(config-cmap)#match dscp cs1
Router(config-cmap)#end-class-map
Router(config)#policy-map gre-ip_in
Router(config-pmap)#class exp1
Router(config-pmap-c)#set traffic-class 1
Router(config-pmap-c)#exit
Router(config-pmap)#class exp2
Router(config-pmap-c)#set traffic-class 2
Router(config-pmap-c)#exit
Router(config-pmap)#class class-default
Router(config-pmap-c)#exit
Router(config-pmap)#end-policy-map
Router(config)#
Router(config)#interface Eth0/0
Router(config-if)#service-policy input gre-ip_in
Router(config-if)#ipv4 address 192.0.2.2 255.255.255.0
Router(config-if)#load-interval 30
Router(config)#
Router(config)#interface Eth1/0
Router(config-if)#ipv4 address 209.165.202.129 255.255.255.224
Router(config-if)#load-interval 30
Router(config-if)#root
Router(config-if)#commit
```

Running Configuration

```

interface tunnel-ip_intf1
  ipv4 address 203.0.113.1 255.255.255.252
  tunnel mode gre ipv4 encap
  tunnel source 13.1.1.1
  tunnel destination 11.1.1.1
!
interface Eth 1/0
  ipv4 address 209.165.201.1 255.255.255.224
!

interface Eth 0/0
  ipv4 address 198.51.100.1 255.255.255.0
!
!

/*Configuration for intermediate hop router (P1)*/
interface Eth1/0
  ipv4 address 198.51.100.2 255.255.255.0
!

interface Eth0/0
  ipv4 address 203.0.113.1 255.255.255.0
!
!
/*Configuration for intermediate hop router (P2)*/
interface Eth1/0
  ipv4 address 203.0.113.2 255.255.255.0
!
interface Eth0/0
  ipv4 address 192.0.2.1 255.255.255.0
!
!
mpls ip-ttl-propagate disable
hw-module profile qos gre-exp-classification-enable
reload loc all
class-map match-any exp1
  match mpls experimental topmost 1
  end-class-map
!
class-map match-any exp2
  match mpls experimental topmost 2
  end-class-map
!
class-map match-any cs1
  match dscp cs1
  end-class-map
!
policy-map gre-ip_in
  class exp1
    set traffic-class 1
!
class exp2
  set traffic-class 2
!

```

```

class class-default

!
end-policy-map
!
interface Eth0/0
 service-policy input gre-ip_in
 ipv4 address 192.0.2.2 255.255.255.0
 load-interval 30

!
interface Eth1/0
 ipv4 address 209.165.202.129 255.255.255.224
 load-interval 30
!

```

Verification

Run the **show policy-map** command on PE2 (decapsulation node) to view the classification statistics that confirm QoS classification is on the MPLS header.

```

Router#show policy-map int Eth1/0
Eth1/0 input: gre-ip_in

Class exp1
  Classification statistics      (packets/bytes)  (rate - kbps)
  Matched                      : 55436316/8426320032  504105
  Transmitted                   : 55436316/8426320032  504105
  Total Dropped                 : 0/0                0
Class exp2
  Classification statistics      (packets/bytes)  (rate - kbps)
  Matched                      : 55436286/8426315472  504105
  Transmitted                   : 55436286/8426315472  504105
  Total Dropped                 : 0/0                0
Class class-default
  Classification statistics      (packets/bytes)  (rate - kbps)
  Matched                      : 0/0                0
  Transmitted                   : 0/0                0
  Total Dropped                 : 0/0                0
Policy Bag Stats time: 1648011883484

```

When you don't enable QoS classification on the MPLS header, the **show policy-map** command on PE2 (decapsulation node) confirms that the classification is IP precedence (under **class-default**).

```

Router#show policy-map int Eth1/0
Eth1/0 input: gre-ip_in

Class exp1
  Classification statistics      (packets/bytes)  (rate - kbps)
  Matched                      : 0/0                0
  Transmitted                   : 0/0                0
  Total Dropped                 : 0/0                0
Class exp2
  Classification statistics      (packets/bytes)  (rate - kbps)
  Matched                      : 0/0                0
  Transmitted                   : 0/0                0
  Total Dropped                 : 0/0                0
Class class-default
  Classification statistics      (packets/bytes)  (rate - kbps)
  Matched                      : 108028694/16420361488  1008187
  Transmitted                   : 108028694/16420361488  1008187
  Total Dropped                 : 0/0                0
Policy Bag Stats time: 1648013053478

```

Terms Used for Classifying Packets Based On MPLS Experimental Bits in MPLS Over GRE

Generic Routing Encapsulation (GRE)

A protocol used to encapsulate packets, GRE is useful when you need to transport packets across an unsupported network protocol, say IPv6 packets across an IPv4 network. In this case, IPv6 packets are encapsulated or wrapped around by packets that support the protocol (IPv4) and transported across the network. This is akin to cars being transported across oceans (unsupported protocol for cars) on cargo ships (the ocean being the supported protocol for the ships).

GRE Tunneling

The encapsulation of packets within other packets is called GRE tunneling. Here, if packets are to be transported from one router to another without any additional processing by intermediate routers and devices, you can configure a GRE tunnel between the two routers. As the packets flow across the network, the intermediate routers read the forwarding information on the packet headers and send them to their next hop. This is similar to the cars now being transported on a cargo truck on land, passing through a tunnel to reach the other end of the road faster, with no other action taking place on the cars as they are carried on the truck inside the tunnel. Without the tunnel, transport across this route would be impossible, akin to an unsupported network between the two ends of the GRE tunnel.

GRE Headers

Each packet consists of the payload—the actual packet content—and an IP header that contains information critical for the packet transportation: the source address, the destination address, packet number, packet length, and so on.

As with other network protocols, GRE adds its own headers to the packets: the GRE header that shows the protocol used by the encapsulated packet (the cars, in our preceding example) and an outer IP header that wraps the encapsulated packet's payload and IP header. A GRE header thus has two IP headers.

MPLS over GRE

A mechanism for tunneling MPLS packets over non-MPLS networks by creating a GRE tunnel across a non-MPLS network. The MPLS packets are encapsulated within the GRE tunnel packets, and the encapsulated packets traverse the non-MPLS network through the GRE tunnel. When GRE tunnel packets reach the other side of the non-MPLS network, the GRE tunnel packet header is removed and the inner MPLS packet is forwarded to its final destination.

QPPB

QoS Policy Propagation via BGP (QPPB) is a mechanism that allows propagation of quality of service (QoS) policy and classification by the sending party that is based on the following:

- Access lists
- Community lists
- Autonomous system paths in the Border Gateway Protocol (BGP)

Thus, helps in classification that is based on the destination address instead of the source address.

QoS policies that differentiate between different types of traffic are defined for a single enterprise network. For instance, one enterprise may want to treat important web traffic, not-important web traffic, and all other data traffic as three different classes. And thereafter, use the different classes for the voice and video traffic.

Hence, QPPB is introduced to overcome the following problems:

- The administrative challenges of classifying that is based on ACLs.
- The administrative problems of just listing the networks that need premium services.

QPPB allows marking of packets that are based on QoS group value associated with a Border Gateway Protocol (BGP) route.

Benefits of QPPB

- QPPB provides an IP prefix-based QoS capability.
- Traffic to IP addresses that have specific IP prefixes can be prioritized above other IP addresses.
- IP prefixes of interest are tagged through the control plane that uses common BGP route-map techniques, including the community attribute.
- Traffic to the tagged BGP prefixes is then classified and prioritized via the data forwarding plane by using the IOS-XR MQC (Modular QoS CLI) mechanisms, such as re-marking.
- QPPB provides the glue between the BGP control plane and the IP data forwarding plane in support of IP prefix-based QoS.
- BGP configuration within QPPB uses a table map to match specific prefixes learned through BGP neighbors, and then sets the router's local QoS Group variable maintained within the Forwarding Information Base (FIB) for those specific prefixes.
- The router supports a subset of full QPPB options - only IP destination prefix mode on input policy is supported.

Figure 4: Sample Scenario

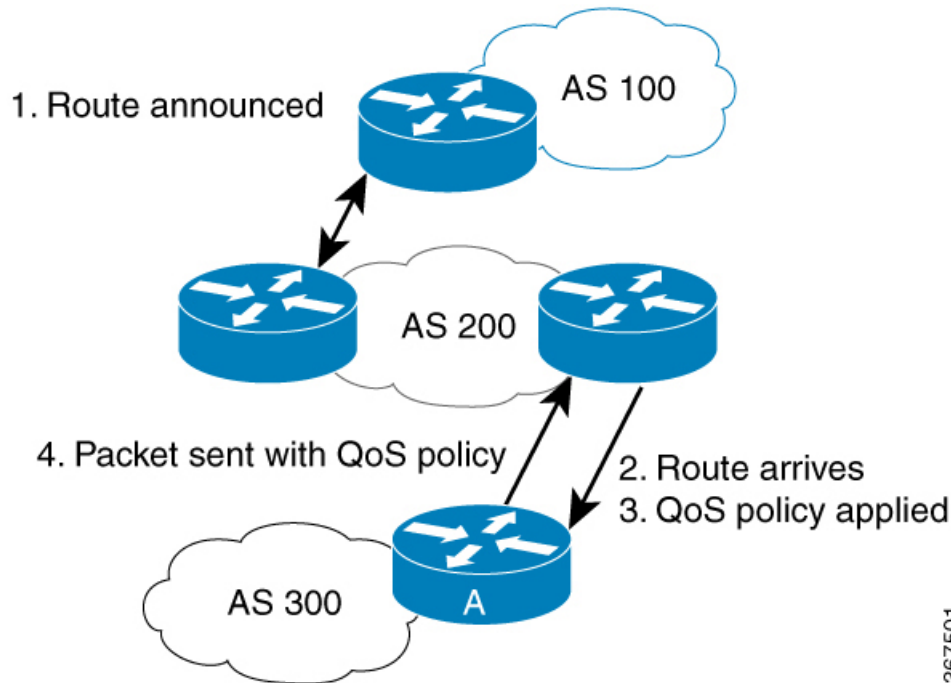

Router A learns routes from AS 200 and AS 100. QoS policy is applied to any ingress interface of Router A to match the defined route maps with destination prefixes of incoming packets. Matching packets on Router A to AS 200 or AS 100 are sent with the appropriate QoS policy from Router A.

BGP maintains a scalable database of destination prefixes, QPPB, by using BGP table maps. BGP adds the ability to map a qos-group value to desired IP destinations. These qos-group values are used in QoS policies applied locally on ingress interfaces. Whenever a packet bound for such destinations is encountered, the qos-group value matching that destination route looks up with work inside the policy classmap, and marks that packet for any configured policy actions.

QPPB: Guidelines and Limitations

- QPPB is supported only on the -SE variants of NCS 5700-line card-based routers and the following -SE variants of NCS 5500-line card-based routers:
 - NCS-55A1-36H-SE-S
 - NCS-55A2-MOD-SE-H-S
 - NCS-55A2-MOD-SE-S
 - NC55-36x100G-A-SE
 - NC55-MOD-A-SE-S
- QPPB doesn't work for /32 IPv4 prefixes on NCS 5500 line card-based routers when you enable the `hw-module fib mpls label lsr-optimized` profile.
- You must configure the `hw-module profile qos ipv6 short` command for QPPB to work with IPv6 address families and packets.

- When you enable the peering mode (using the `hw-module profile qos ingress-model peering` command), the QPPB feature doesn't work.

Configuration Workflow

Use the following configuration workflow for QPPB:

- Define route policy.
- Put Route policy at table-policy attach point under BGP.
- Define classmaps and ingress policy to use the qos-groups that are used in table-policy.
- Enable ipv4/ipv6 QPPB configuration under the desired interfaces.
- Configure the QPPB hardware profile, `hw-module profile qos ipv6 short`.
- If you use ipv6 QPPB, you must reload that linecard. If you use only ipv4 QPPB, linecard reload is not mandatory.

Define route policy

A routing policy instructs the router to inspect routes, filter them, and potentially modify their attributes as they are accepted from a peer, advertised to a peer, or redistributed from one routing protocol to another.

The routing policy language (RPL) provides a language to express routing policy. You must set up destination prefixes either to match inline values or one of a set of values in a prefix set.

Example:

```
prefix-set prefix-list-v4
  70.1.1.1,
  70.2.1.0/24,
  70.2.2.0/24 ge 28,
  70.2.3.0/24 le 28
end-set
prefix-set prefix-list-v6
  2001:300::2,
  2003:200::3
end-set

route-policy qppb1
  if destination in (60.60.0.2) then
    set qos-group 5
  elseif destination in prefix-list-v4 then
    set qos-group 4
  else
    set qos-group 1
  pass
endif
end-policy
```

For NC57 line cards, the set qos-group value under the route policy for QPPB support is 0-15. Even though the set qos-group value option displays supported values <0-31> as show below, the configuration fails for any value above 15 for NC57 line cards.

```
RP/0/RP0/CPU0:Fretta(config-rpl-if)#set qos-group ?
<0-31>      decimal number
```

Put Route policy at table-policy attach point under BGP

The table-policy attach point permits the route policy to perform actions on each route as they are installed into the RIB routing table. QPPB uses this attachment point to intercept all routes as they are received from peers. Ultimately the RIB will update the FIB in the hardware forwarding plane to store destination prefix routing entries, and in cases where table policy matches a destination prefix, the qos-group value is also stored with the destination prefix entry for use in the forwarding plane.

Example:

```
router bgp 900
  [vrf <name>]
  bgp router-id 22.22.22.22
  address-family ipv4 unicast
    table-policy qppb1
  address-family ipv6 unicast
    table-policy qppb2
  neighbor 30.2.2.1
    remote-as 500
    address-family ipv4 unicast
      route-policy pass in
      route-policy pass out
    address-family ipv6 unicast
      route-policy pass in
      route-policy pass out
```

Ingress interface QOS and ipv4/ipv6 bgp configuration

QPPB would be enabled per interface and individually for V4 and V6. An ingress policy would match on the qos groups marked by QPPB and take desired action.

If a packet is destined for a destination prefix on which BGP route policy has stored a qos-group, but it ingresses on an interface on which qppb is not enabled, it would not be remarked with qos-group.

Earlier, router supported matching on qos-group only in peering profile 'hw-module profile qos ingress-model peering location <>'. QPPB now permits classmaps to match qos-group in the default "non peering mode qos" as well. Also QPPB and hierarchical QOS policy profiles can work together if Hqos is used.

Example:

```
class-map match-any qos-group5
  match qos-group 5
end-class-map

class-map match-any qos-group4
  match qos-group 4
end-class-map

policy-map ingress-marker-pol
  class qos-group5
    set precedence 0
    set discard-class 0
    set traffic-class 1

  class qos-group4
    set precedence 1
    set discard-class 1
    set traffic-class 2
  class class-default

end-policy-map
```

Configuring QPPB on an Interface

1. RP/0/RP0/CPU0:router # configure
Enters interface configuration mode and associates one or more interfaces to the VRF.
2.
RP/0/RP0/CPU0:router(config)# interface
type interface-path-id
Enters interface configuration mode and associates one or more interfaces to the VRF.
3. **ipv4 | ipv6 bgp policy propagation inputqos-groupdestination**
Example:

RP/0/RP0/CPU0:router(config-if)# ipv4 bgp policy propagation input qos-group destination

Enables QPPB on an interface
4. commit

Egress Interface Configuration

The traffic-class set on ingress has no existence outside the device. Also, traffic-class is not a part of any packet header but is associated internal context data on relevant packets. It can be used as a match criteria in an egress policy to set up various fields on the outgoing packet or shape flows.

Restrictions:

- No IP precedence marking.
- No policing on egress policy.

```
class-map match-any level1
  match traffic-class 1
end-class-map

class-map match-any level2
  match traffic-class 2
end-class-map

policy-map output-pol
  class level1
    bandwidth percent 50
  class level2
    bandwidth percent 20
    queue-limit 50 ms
end-policy-map

interface hun 0/5/0/0
  ipv4 address 30.1.1.1/24
  ipv6 address 2001:da8:b0a:12f0::1/64
  service-policy output output-pol
```



CHAPTER 5

Configuring Modular QoS Congestion Avoidance

This chapter covers the following topics:

- [Modular QoS Congestion Avoidance](#) , on page 113
- [Tail Drop and the FIFO Queue](#), on page 114
- [Fair Adaptive Drop Thresholds](#) , on page 116
- [Random Early Detection and TCP](#), on page 120
- [Weighted Random Early Detection](#), on page 122
- [Explicit Congestion Notification \(ECN\)](#), on page 130

Modular QoS Congestion Avoidance

Congestion avoidance techniques monitor traffic flow to anticipate and avoid congestion at common network bottlenecks. Avoidance techniques are implemented before congestion occurs as compared with congestion management techniques that control congestion after it has occurred.



Note From Cisco IOS XR Release 7.3.1 onwards, systems with Cisco NC57 line cards running in compatibility mode support QoS over Layer 2 services for:

- Local switching [xconnect or bridging]
- L2 VPN – VPWS

Starting with Cisco IOS XR Release 7.4.1 systems with Cisco NC57 line cards running in native mode support QoS over Layer 2 services for:

- Local switching [xconnect or bridging]
 - L2 VPN – VPWS
-



Note For traffic requiring header decapsulation, the size of the header that is being removed is still included for the egress queuing actions. To offset this header size (required to achieve line rate for small frame sizes), configure an egress user policy with user overhead accounting on the egress interface. This policy can be a dummy policy configuration as well (allowing full traffic rate), if a policy isn't already in use or required on the egress interface.

You can enable user overhead accounting using the optional configuration of **accounting user-defined <overhead size in bytes>** while attaching the service policy on the egress interface.

Congestion avoidance is achieved through packet dropping. The router supports these QoS congestion avoidance techniques:

- [Tail Drop and the FIFO Queue, on page 114](#)
- [Random Early Detection and TCP, on page 120](#)
- [Weighted Random Early Detection, on page 122](#)

Tail Drop and the FIFO Queue

Tail drop is a congestion avoidance technique that drops packets when an output queue is full until congestion is eliminated. Tail drop treats all traffic flow equally and does not differentiate between classes of service. It manages the packets that are unclassified, placed into a first-in, first-out (FIFO) queue, and forwarded at a rate determined by the available underlying link bandwidth.

Tail Drop and the FIFO Queue: Tip to Optimize Hardware Resources

Tail drop is a congestion avoidance mechanism that works by discarding packets at the tail end of a queue when the queue length exceeds a certain threshold. These thresholds are critical in managing network congestion and are determined based on the Guaranteed Service Rate (GSR) of a traffic class, typically set at a value representing 10 milliseconds of the GSR.

Tail Drop Thresholds-Rate Class Profile Association and ASIC Limitations

When configuring tail drop thresholds, each threshold value is associated with a rate class profile, which defines the performance characteristics for that threshold. (A rate class profile typically includes bandwidth limits, priority levels, queueing policies, and drop policies like tail drop thresholds. These profiles manage how different types of traffic are treated as they traverse the network, ensuring that critical services get the bandwidth and latency treatment they require.)

However, there is a limitation: each ASIC can support only up to 64 rate class profiles. This hardware constraint necessitates efficient utilization of these profiles.

Resource Optimization Tip: Share Rate Class Profiles

Since multiple traffic classes can have the same tail drop threshold value, they can share a rate class profile. This sharing conserves hardware resources, allowing for a more scalable network design. Conversely, if each traffic class requires a unique tail drop threshold, more rate class profiles must be created, which can quickly exhaust the available hardware resources.

Therefore, to optimize network performance and resource utilization, we recommend that you strategically fine-tune tail drop threshold values so that more traffic classes share rate class profiles.

Configure Tail Drop

Packets satisfying the match criteria for a class accumulate in the queue reserved for the class until they are serviced. The **queue-limit** command is used to define the maximum threshold for a class. When the maximum threshold is reached, the enqueued packets to the class queue result in tail drop (packet drop).

Restrictions

- When configuring the **queue-limit** command, you must configure one of the following commands: **priority**, **shape average**, **bandwidth** or **bandwidth remaining**, except for the default class.

Configuration Example

You have to accomplish the following to complete the tail drop configuration:

1. Creating (or modifying) a policy map that can be attached to one or more interfaces to specify a service policy
2. Associating the traffic class with the traffic policy
3. Specifying the maximum limit the queue can hold for a class policy configured in a policy map.
4. Specifying priority to a class of traffic belonging to a policy map.
5. (Optional) Specifying the bandwidth allocated for a class belonging to a policy map or specifying how to allocate leftover bandwidth to various classes.
6. Attaching a policy map to an output interface to be used as the service policy for that interface.

```
Router# configure
Router(config)# class-map qos-1
Router(config-cmap)# match traffic-class 1
Router(config-cmap)# commit
Router(config-pmap)# exit

Router(config)# policy-map test-qlimit-1
Router(config-pmap)# class qos-1
Router(config-pmap-c)# queue-limit 100 us
Router(config-pmap-c)# priority level 7
Router(config-pmap-c)# exit
Router(config-pmap)# exit

Router(config)# interface HundredGigE 0/6/0/18
Router(config-if)# service-policy output test-qlimit-1
Router(config-if)# commit
```

Running Configuration

```
class-map qos-1
  match traffic-class 1
commit
```

```

policy-map test-qlimit-1
  class qos-1
    queue-limit 100 us
    priority level 7
  !
  class class-default
  !
end-policy-map
!

```

Verification

```
Router# show qos int hundredGigE 0/6/0/18 output
```

```

NOTE:- Configured values are displayed within parentheses
Interface HundredGigE0/6/0/18 ifh 0x3000220 -- output policy
NPU Id:                               3
Total number of classes:               2
Interface Bandwidth:                   100000000 kbps
VOQ Base:                              11176
VOQ Stats Handle:                      0x88550ea0
Accounting Type:                       Layer1 (Include Layer 1 encapsulation and above)
-----
Level1 Class (HP7)                     = qos-1
Egressq Queue ID                       = 11177 (HP7 queue)
TailDrop Threshold                     = 1253376 bytes / 100 us (100 us)
WRED not configured for this class

Level1 Class                           = class-default
Egressq Queue ID                       = 11176 (Default LP queue)
Queue Max. BW.                         = 101803495 kbps (default)
Queue Min. BW.                         = 0 kbps (default)
Inverse Weight / Weight                 = 1 (BWR not configured)
TailDrop Threshold                     = 1253376 bytes / 10 ms (default)
WRED not configured for this class

```

Related Topics

- [Tail Drop and the FIFO Queue, on page 114](#)

Associated Commands

- [queue-limit](#)

Fair Adaptive Drop Thresholds

Fair adaptive drop threshold is a queue management mechanism that

- dynamically sets the tail drop threshold for packet queues that use shared system buffers, based on current system resource usage
- allocates buffer descriptors fairly across all active virtual output queues (VOQs) by recalculating the maximum queue limit for each queue
- prevents a single queue from monopolizing resources, and

- optimizes burst absorption and enhances network stability.

Buffer descriptors are data structures that store information about the memory location, size, and status of each packet or buffer in the queue. The number of available buffer descriptors limits the number of packets that can be queued.

Table 29: Feature History Table

Feature Name	Release Information	Feature Description
Configurable fair adaptive drop thresholds	Release 25.3.1	<p>Introduced in this release on: NCS 5500 line cards</p> <p>You can improve burst absorption and reduce packet drops on both priority and non-priority queues by configuring buffer allocation strategy as per your need. With this feature, you can now configure adaptive limits for buffer descriptor usage per queue at ingress. By configuring different adaptive limits, you control the share of system buffer resources that each queue can consume. This approach optimizes burst handling and helps prevent resource starvation across multiple classes of service.</p> <p>The feature introduces the hw-module profile qos ingress-fadt-set command.</p>

Fair adaptive threshold implementation on NCS 5500 series routers

Fair adaptive drop thresholds are implemented on Cisco NCS 5500 series line cards and fixed routers. These routers have shallow on-chip buffers and a shared dynamic random-access memory (DRAM) buffer for congestion scenarios. The fair adaptive drop threshold mechanism prevents any single VOQ from exceeding a configurable percentage of the available buffer descriptors and protects system stability during traffic bursts.

Example: If a sudden microburst occurs on a low-priority class, the adaptive drop threshold limits the queue's growth, preventing it from consuming excessive buffer resources and causing instability.

How fair adaptive drop thresholds work

Unexpected packet loss (VOQ tail drops) can occur on any traffic class on Cisco NCS 5500 Series line cards and fixed routers, even when traffic rates are below the guaranteed service rate and no sustained congestion exists. This typically happens when a single VOQ consumes excessive buffer resources, starving other VOQs. Using fair adaptive drop threshold dynamically adjusts queue limits (tail drop thresholds) based on available resources, preventing any one VOQ from monopolizing buffers. This ensures balanced buffer allocation across all active queues.

Summary

Key components involved in the process:

- Virtual Output Queue (VOQ): Buffers packets per traffic class.
- Buffer Descriptors: Track packets and buffers in memory.
- Fair adaptive drop thresholds mechanism: Adjusts queue thresholds dynamically to allocate buffer descriptors fairly.
- QoS policy map: Defines queue limits and traffic shaping per class.

The process involves monitoring queue lengths, dynamically adjusting tail drop thresholds, and enforcing limits based on system resource status.

Workflow

These stages describe how fair adaptive drop thresholds impact burst absorption and packet drops:

1. The router receives traffic and enqueues packets per class as defined by the QoS policy.
2. Each queue consumes buffer descriptors as packets are added.
3. The fair adaptive drop thresholds mechanism monitors the total buffer descriptors usage across all VOQs.
4. When a queue approaches its adaptive limit, determined as a percentage (for example, 20%) of available buffer descriptors, the tail drop threshold is enforced, and additional incoming packets are dropped.
5. If you change the system configuration (for example, by adjusting the fair adaptive drop thresholds percentage using the **hw-module profile qos ingress-fadt-set** command), the new threshold applies after you reload the line card.

When...	Then...
A traffic burst occurs on a priority or non-priority class	Fair adaptive drop threshold applies a dynamic queue limit (tail drop threshold) to a congested queue, which can be lower than the configured queue limit
Multiple queues are active on the same core	Fair adaptive drop threshold mechanism dynamically divides buffer descriptor resources among all active queues, reducing risk of system instability.
The system is configured with a high fair adaptive drop thresholds setting	High percentage of available buffer descriptors allocated to a queue; allows better burst absorption on that queue but may adversely impact other active queues.
The system is configured with a low fair adaptive drop thresholds setting	Very low percentage of available buffer descriptors allocated to a queue; results in poor burst absorption but is helpful in high-scale scenarios.
The system is configured with a medium fair adaptive drop thresholds setting	Moderate (default setting) usage of buffer descriptor allocation; an optimal condition for resource usage.
Fair adaptive drop thresholds are disabled (not recommended)	A single congested queue may consume all available resources, risking system instability.

Result

Fair adaptive drop thresholds reduce the likelihood of system instability and packet loss by ensuring fair resource allocation. However, the queue may not reach the configured maximum limit, because the actual maximum depends on the packet size and the number of active queues.

Fair adaptive drop threshold settings

Recommendation: fine-tune queue limits for microburst absorption

Use higher queue limits where possible to improve the system's ability to absorb microbursts.

Requirement: reload line card

Reload the line card after you configure the `hw-module profile qos ingress-fact-set` command to ensure configuration changes take effect.

Fair adaptive drop threshold settings and trade-offs

Use this table to evaluate the fair adaptive drop threshold configuration that best meets your network requirements.

Table 30: Trade-offs for Each Fair Adaptive Drop Threshold Configuration Option

Fair adaptive threshold setting	Burst absorption	Risk of resource starvation
Low	Low	Very low
Medium	Moderate	Moderate
High	High	High
Disable	Very high	Very high, may have negative impact on operations (not recommended)

Configure fair adaptive drop threshold values

To configure fair adaptive drop threshold values, follow these steps.

Before you begin

- Plan for a line card reload to apply the setting.

Procedure

Step 1 Enter hardware module configuration mode.

Example:

```
Router(config)#hw-module profile qos ingress-fadt-set
```

Step 2 Set the fair adaptive drop threshold value.

Example:

```
Router(config)#hw-module profile qos ingress-fadt-set medium
```

This sets the threshold to medium for moderate burst absorption.

Example:

```
Router(config)#hw-module profile qos ingress-fadt-set medium location 0/0/CPU0
```

This configuration sets the threshold to medium specifically for the location or line card, 0/0/CPU0.

If both global and per-location configurations exist for a line card, the per-location configuration takes effect.

Step 3 Reload the line card to apply the setting.

Example:

```
Router#reload location 0/0/CPU0
```

The router enforces the new fair adaptive drop threshold setting, optimizing burst absorption and resource distribution across all active VOQs.

Random Early Detection and TCP

The Random Early Detection (RED) congestion avoidance technique takes advantage of the congestion control mechanism of TCP. By randomly dropping packets prior to periods of high congestion, RED tells the packet source to decrease its transmission rate. Assuming the packet source is using TCP, it decreases its transmission rate until all packets reach their destination, indicating that the congestion is cleared. You can use RED as a way to cause TCP to slow transmission of packets. TCP not only pauses, but it also restarts quickly and adapts its transmission rate to the rate that the network can support.

RED distributes losses in time and maintains normally low queue depth while absorbing traffic bursts. When enabled on an interface, RED begins dropping packets when congestion occurs at a rate you select during configuration.

Configure Random Early Detection

The **random-detect** command with the **default** keyword must be used to enable random early detection (RED). The **random-detect default** command enables RED using system-defined default thresholds. These thresholds are derived dynamically based on router-specific queue characteristics and available buffer resources. Because the values are hardware-dependent, explicit minimum and maximum thresholds are not displayed or configurable when the default option is used.

Guidelines

If you configure the **random-detect default** command on any class including class-default, you must configure one of the following commands: **shape average**, **bandwidth**, and **bandwidth remaining**.

Configuration Example

You have to accomplish the following to complete the random early detection configuration:

1. Creating (or modifying) a policy map that can be attached to one or more interfaces to specify a service policy
2. Associating the traffic class with the traffic policy
3. Enabling RED with default minimum and maximum thresholds.
4. (Optional) Specifying the bandwidth allocated for a class belonging to a policy map or specifying how to allocate leftover bandwidth to various classes.
5. (Optional) Shaping traffic to the specified bit rate or a percentage of the available bandwidth.
6. Attaching a policy map to an output interface to be used as the service policy for that interface.

```
Router# configure
Router(config)# class-map qos-1
Router(config-cmap)# match traffic-class 1
Router(config-cmap)# commit
Router(config-pmap)# exit

Router# configure
Router(config)# policy-map test-wred-2
Router(config-pmap)# class qos-1
Router(config-pmap-c)# random-detect default
Router(config-pmap-c)# shape average percent 10
Router(config-pmap-c)# end-policy-map
Router(config)# commit
Router(config)# interface HundredGigE 0/6/0/18
Router(config-if)# service-policy output test-wred-2
Router(config-if)# commit
```

Running Configuration

```
class-map qos-1
  match traffic-class 1
commit

policy-map test-wred-2
  class qos-1
    random-detect default
    shape average percent 10
  !
  class class-default
  !
end-policy-map
!

interface HundredGigE 0/6/0/18
  service-policy output test-wred-2
!
```

Verification

```
Router# show qos int hundredGigE 0/6/0/18 output

NOTE:- Configured values are displayed within parentheses
Interface HundredGigE0/6/0/18 ifh 0x3000220 -- output policy
NPU Id: 3
Total number of classes: 2
Interface Bandwidth: 100000000 kbps
VOQ Base: 11176
VOQ Stats Handle: 0x88550ea0
Accounting Type: Layer1 (Include Layer 1 encapsulation and above)
-----
Level1 Class = qos-1
Egressq Queue ID = 11177 (LP queue)
Queue Max. BW. = 10082461 kbps (10 %)
Queue Min. BW. = 0 kbps (default)
Inverse Weight / Weight = 1 (BWR not configured)
Guaranteed service rate = 10000000 kbps
TailDrop Threshold = 12517376 bytes / 10 ms (default)

Default RED profile
WRED Min. Threshold = 12517376 bytes (10 ms)
WRED Max. Threshold = 12517376 bytes (10 ms)

Level1 Class = class-default
Egressq Queue ID = 11176 (Default LP queue)
Queue Max. BW. = 101803495 kbps (default)
Queue Min. BW. = 0 kbps (default)
Inverse Weight / Weight = 1 (BWR not configured)
Guaranteed service rate = 50000000 kbps
TailDrop Threshold = 62652416 bytes / 10 ms (default)
WRED not configured for this class
```

Related Topics

- [Random Early Detection and TCP, on page 120](#)

Associated Commands

- [random-detect](#)

Weighted Random Early Detection

The Weighted Random Early Detection (WRED) drops packets selectively based on any specified criteria, like discard-class. WRED uses this matching criteria to determine how to treat different types of traffic.

You can configure WRED using the [random-detect](#) command and different discard-class values. The value can be range or a list of values that are valid for that field. You can also use minimum and maximum queue thresholds to determine the dropping point. Ensure that the WRED maximum threshold value is close to the queue limit. When the maximum threshold value is reached, packets start to get dropped.

You can also configure WRED threshold values per discard class. Such an approach helps differentiate when to drop packets among different discard classes, helping prioritize packets among discard classes.

When a packet arrives, the following actions occur:

- The average queue size is calculated.
- If the average queue size is less than the minimum queue threshold, the arriving packet is queued.
- If the average queue size is between the minimum queue threshold for that type of traffic and the maximum threshold for the interface, the packet is either dropped or queued, depending on the packet drop probability for that type of traffic.
- If the average queue size is greater than the maximum threshold, the packet is dropped.

Average Queue Size for WRED

The router automatically determines the parameters to use in the WRED calculations. The average queue size is based on the previous average and current size of the queue. The formula is:

$$\text{average} = (\text{old_average} * (1 - x)) + (\text{current_queue_size} * x)$$

where x is the exponential weight factor.

For high values of x , the previous average becomes more important. A large factor smooths out the peaks and lows in queue length. The average queue size is unlikely to change very quickly, avoiding a drastic change in size. The WRED process is slow to start dropping packets, but it may continue dropping packets for a time after the actual queue size has fallen below the minimum threshold. The slow-moving average accommodates temporary bursts in traffic.



Note

- The exponential weight factor, x , is fixed and is not user configurable.
- If the value of x gets too high, WRED does not react to congestion. Packets are sent or dropped as if WRED were not in effect.
- If the value of x gets too low, WRED overreacts to temporary traffic bursts and drops traffic unnecessarily.

For low values of x , the average queue size closely tracks the current queue size. The resulting average may fluctuate with changes in the traffic levels. In this case, the WRED process responds quickly to long queues. Once the queue falls below the minimum threshold, the process stops dropping packets.

Configure Weighted Random Early Detection

This configuration task is similar to that used for RED except that the **random-detect** command is not configured in RED.

Restrictions

- You cannot use the **random-detect** command in a class configured with the **priority** command, because WRED cannot be configured in a class that has been set for priority queueing (PQ).
- When configuring the **random-detect** command, you must configure one of the following commands: **shape average**, **bandwidth**, and **bandwidth remaining**.
- Do not enable Explicit Congestion Notification (ECN) and Weighted Random Early Detection (WRED) at the same time. So, do not use the following commands together:

```

*/ ECN Configuration */
Router(config-pmap-c) # random-detect ecn

*/ WRED Configuration */
Router(config-pmap-c) # random-detect discard-class 0 10 ms 500 ms

```

Configuration Example

You have to accomplish the following to complete the random early detection configuration:

1. Creating (or modifying) a policy map that can be attached to one or more interfaces to specify a service policy
2. Associating the traffic class with the traffic policy
3. Enabling WRED by specifying the match criteria (discard-class).
4. (Optional) Specifying the bandwidth allocated for a class belonging to a policy map or specifying how to allocate leftover bandwidth to various classes.
5. (Optional) Shaping traffic to the specified bit rate or a percentage of the available bandwidth.
6. (Optional) Changing queue limit to fine-tune the amount of buffers available for each queue.
7. Attaching a policy map to an output interface to be used as the service policy for that interface.

```

Router# configure
Router(config)# class-map qos-1
Router(config-cmap)# match traffic-class 1
Router(config-cmap)# commit
Router(config-pmap)# exit

Router# configure
Router(config)# policy-map test-wred-1
Router(config-pmap)# class qos-1
Router(config-pmap-c)# random-detect default
Router(config-pmap-c)# random-detect discard-class 0 10 ms 500 ms
Router(config-pmap-c)# shape average percent 10
Router(config-pmap-c)# commit

Router(config)# interface HundredGigE 0/6/0/18
Router(config-if)# service-policy output policy1
Router(config-if)# commit

```

Running Configuration

```

class-map qos-1
 match traffic-class 1
 commit

policy-map test-wred-1
 class qos-1
  random-detect default
  random-detect discard-class 0 10 ms 500 ms
  shape average percent 10
 !
 class class-default
 !
 end-policy-map
 !

```

```
interface HundredGigE 0/6/0/18
 service-policy output test-wred-1
 !
```

Verification

```
Router# show qos int hundredGigE 0/0/0/20 output
```

```
NOTE:- Configured values are displayed within parentheses
Interface HundredGigE0/0/0/20 ifh 0x38 -- output policy
NPU Id:                                0
Total number of classes:                2
Interface Bandwidth:                    100000000 kbps
Policy Name:                            test-wred-1
VOQ Base:                               1184
Accounting Type:                        Layer1 (Include Layer 1 encapsulation and above)
-----
Level1 Class                            = qos-1
Egressq Queue ID                        = 1185 (LP queue)
Queue Max. BW.                          = 10000152 kbps (10 %)
Queue Min. BW.                          = 0 kbps (default)
Inverse Weight / Weight                  = 1 / (BWR not configured)
Guaranteed service rate                  = 10000000 kbps
Peak burst                               = 36864 bytes (default)
TailDrop Threshold                       = 1250000896 bytes / 1000 ms (default)

WRED profile for Discard_Class 0
WRED Min. Threshold                      = 12499968 bytes (10 ms)
WRED Max. Threshold                      = 624999936 bytes (500 ms)

Default RED profile
WRED Min. Threshold                      = 7499776 bytes (6 ms)
WRED Max. Threshold                      = 12499968 bytes (10 ms)

WRED ECN                                 = Disabled

Level1 Class                            = class-default
Egressq Queue ID                        = 1184 (Default LP queue)
Queue Max. BW.                          = no max (default)
Queue Min. BW.                          = 0 kbps (default)
Inverse Weight / Weight                  = 1 / (BWR not configured)
Guaranteed service rate                  = 50000000 kbps
Peak burst                               = 36864 bytes (default)
TailDrop Threshold                       = 62499840 bytes / 10 ms (default)
WRED not configured for this class
```

Related Topics

- [Weighted Random Early Detection, on page 122](#)
- [Configure Random Early Detection, on page 120](#)

Associated Commands

- [random-detect](#)

Configure WRED Counters by Class

Table 31: Feature History Table

Feature Name	Release Information	Feature Description
Configure WRED Counters by Class on Cisco NCS 5700 Series Base (Non-SE) Version Line Cards	Release 7.8.1	You can now view WRED statistics per class on Cisco NCS 5700 Series base (non-SE) version line cards operating in native mode. This functionality provides a more accurate and granular statistics profile for packet drops.
Configure WRED Counters by Class	Release 7.4.1	<p>This feature enables the display of WRED statistics per class, thus providing a more accurate and granular statistics profile for packet drops. Such insight allows you to monitor, anticipate, and avoid congestion at common bottlenecks on your network.</p> <p>This functionality introduces the hw-module profile qos wred-stats-enable command and modifies the output of the show policy-map interface command.</p>

- **Statistics profile**—Up until now, running the **show policy-map interface** command displayed the drop statistics per class under tail drop. Which meant that no matter what drop mechanism you deployed ([Tail Drop and the FIFO Queue, on page 114](#), [Random Early Detection and TCP, on page 120](#), or [Weighted Random Early Detection, on page 122](#)), the statistics profile that displayed was a number aggregated under the tail drop entry. Given that WRED provides a far more granular control over packet drops than the other mechanisms, the generic statistics profile didn't provide you with the validation that you required for your WRED actions.
- **WRED counters by class**—This functionality introduces a new command, **hw-module profile qos wred-stats-enable**. Configuring this command enables the display of WRED and RED statistics per class, thus providing a more accurate and granular statistic for packet drops.
- **Why WRED counters by class**—Prior to this functionality, you did not have visibility into the WRED drop counters and had no way to validate WRED actions. With this improvement, the **show policy-map interface** command provides the much-needed visibility by clearly depicting the drop counters per class for WRED. This visibility gives you the confidence that WRED is indeed in action and is providing the requisite congestion avoidance.
- **Guidelines and limitations**
 - WRED max-drop threshold statistics are unavailable.
 - WRED statistics are collected separately for each drop precedence value.

- **WRED counters support cheat-sheet**—Here's a quick look at some key support areas and their details for WRED counters by class.

Support	Details
Line card	Supported on Cisco NC57 line cards with external Ternary Content-Addressable Memory (TCAM) operating in native mode. Supported on Cisco NCS 5700 Series base (non-SE) version line cards operating in native mode.
Statistics	WRED drop count is available for all the supported discard-values (from 0 through 2).

- **Configure WRED counters by class**—To configure WRED counters by class you must:
 - Configure the **hw-module profile** for WRED statistics. Manually reload the chassis to activate the profile.
 - Configure a class map.
 - Create a service policy map.
 - Attach the service policy to an interface.

```

/*Configure hw-module profile for wred stats*/
Router#conf
Router(config)#hw-module profile qos wred-stats-enable
Router(config)#commit
Router#reload

/*Configure a class map*/
Router(config)#class-map TC3
Router(config-cmap)#match traffic-class 3
Router(config-cmap)#commit
Router(config-cmap)#end-class-map

/*Create a service policy map*/
Router(config)#policy-map EGRESS_WRED
Router(config-pmap)#class TC3
Router(config-pmap-c)#shape average 1 gbps
Router(config-pmap-c)#random-detect discard-class 0 1 ms 2 ms
Router(config-pmap-c)#random-detect discard-class 1 3 ms 5 ms
Router(config-pmap-c)#random-detect discard-class 2 10 ms 20 ms
Router(config-pmap-c)#commit
Router(config-pmap)#end-policy-map

/*Attach the service policy to an interface*/
Router(config)#int hundredGigE 0/7/0/2
Router(config-if)#service-policy output EGRESS_WRED
Router(config-if)#commit

```

- **Running Configuration**

```

class-map match-any TC3
  match traffic-class 3
  end-class-map
!
policy-map EGRESS_WRED
  class TC3
    shape average 1 gbps
    random-detect discard-class 0 1 ms 2 ms
    random-detect discard-class 1 3 ms 5 ms
    random-detect discard-class 2 10 ms 20 ms
  !
  class class-default
  !
  end-policy-map
!
interface HundredGigE0/7/0/2
  service-policy output EGRESS_WRED
  ipv4 address 192.168.0.1 255.255.255.0
!

```

• Verification

```

Router#show qos int hundredGigE 0/7/0/2 output
NOTE:- Configured values are displayed within parentheses
Interface HundredGigE0/7/0/2 ifh 0xe000088 -- output policy
NPU Id:                                0
Total number of classes:                2
Interface Bandwidth:                    100000000 kbps
Policy Name:                            EGRESS_WRED
SPI Id:                                 0x0
VOQ Base:                               1160
PFC enabled:                            0
Accounting Type:                        Layer1 (Include Layer 1 encapsulation and above)
-----
Level1 Class                            = TC3
Egressq Queue ID                        = 1163 (LP queue)
Queue Max. BW.                          = 1000000 kbps (1 gbits/sec)
Queue Min. BW.                          = 0 kbps (default)
Inverse Weight / Weight                  = 1 / (BWR not configured)
Guaranteed service rate                  = 1000000 kbps
Peak burst                               = 36864 bytes (default)
TailDrop Threshold                       = 4999168 bytes / 40 ms (default)

WRED profile for Discard_Class 0
WRED Min. Threshold                      = 124928 bytes (1 ms)
WRED Max. Threshold                      = 249856 bytes (2 ms)

WRED profile for Discard_Class 1
WRED Min. Threshold                    = 374784 bytes (3 ms)
WRED Max. Threshold                    = 624896 bytes (5 ms)

WRED profile for Discard_Class 2
WRED Min. Threshold                    = 1249792 bytes (10 ms)
WRED Max. Threshold                    = 2499840 bytes (20 ms)

Default RED profile
WRED Min. Threshold                      = 256 bytes (0 ms)
WRED Max. Threshold                      = 256 bytes (0 ms)

WRED ECN                                 = Disabled

Level1 Class                             = class-default
Egressq Queue ID                         = 1160 (Default LP queue)
Queue Max. BW.                           = no max (default)

```

```

Queue Min. BW. = 0 kbps (default)
Inverse Weight / Weight = 1 / (BWR not configured)
Guaranteed service rate = 50000000 kbps
Peak burst = 36864 bytes (default)
TailDrop Threshold = 62499840 bytes / 10 ms (default)
WRED not configured for this class

```

- **show policy-map interface output for statistics verification**

```
Router#show policy-map int hundredGigE 0/7/0/2 output
```

```
HundredGigE0/7/0/2 output: EGRESS_WRED
```

```

Class TC3
Classification statistics          (packets/bytes)      (rate - kbps)
  Matched                        :          1151236/1151236000      0
  Transmitted                    :          578807/578807000      0
  Total Dropped                  :          572429/572429000      0
Queueing statistics
  Queue ID                       :          1163
  Taildropped(packets/bytes)     :          572429/572429000

WRED profile for Discard Class 0
RED Transmitted (packets/bytes)   : 0/0
RED random drops(packets/bytes)   : 0/0
RED maxthreshold drops(packets/bytes) : N/A
RED ecn marked & transmitted(packets/bytes): N/A
WRED profile for Discard Class 1
RED Transmitted (packets/bytes)   : 0/0
RED random drops(packets/bytes)   : 0/0
RED maxthreshold drops(packets/bytes) : N/A
RED ecn marked & transmitted(packets/bytes): N/A
WRED profile for Discard Class 2
RED Transmitted (packets/bytes)   : 578807/578807000
RED random drops(packets/bytes)   : 572429/572429000
RED maxthreshold drops(packets/bytes) : N/A
RED ecn marked & transmitted(packets/bytes): N/A
RED profile (default)
RED Transmitted (packets/bytes)   : 0/0
RED random drops(packets/bytes)   : 0/0
RED maxthreshold drops(packets/bytes) : N/A
RED ecn marked & transmitted(packets/bytes): N/A
Class class-default
Classification statistics          (packets/bytes)      (rate - kbps)
  Matched                        :              0/0              0
  Transmitted                    :              0/0              0
  Total Dropped                  :              0/0              0
Queueing statistics
  Queue ID                       :          1160
  Taildropped(packets/bytes)     :              0/0

```

- **Clear WRED statistics on an interface**

Run the following command to clear WRED statistics on an interface.

```
Router#clear qos counters int hundredGigE 0/7/0/2 output
```

Associated Commands

[hw-module profile qos wred-stats-enable](#)

Explicit Congestion Notification (ECN)

Weighted Random Early Detection (WRED) is implemented at the core routers of a network. Edge routers assign IP precedences to packets, as the packets enter the network. With WRED, core routers then use these precedences to determine how to treat different types of traffic. WRED provides separate thresholds and weights for different IP precedences, enabling the network to provide different qualities of service, in regard to packet dropping, for different types of traffic. Standard traffic may be dropped more frequently than premium traffic during periods of congestion.

ECN is an extension to WRED. ECN marks packets instead of dropping them when the average queue length exceeds a specific threshold value. When configured, ECN helps routers and end hosts to understand that the network is congested and slow down sending packets. However, if the number of packets in the queue is above the maximum threshold, packets are dropped based on the drop probability.

WRED starts dropping packets probabilistically before a queue becomes full, which means that it works during enqueueing. ECN marking with WRED (ECN-WRED) takes place as packets are about to be transmitted from the queue (during the dequeue process), when the router decides whether to forward, drop, or mark packets based on the congestion state of the queue. Also, WRED and ECN don't work together.

RFC 3168, *The Addition of Explicit Congestion Notification (ECN) to IP*, states that with the addition of active queue management (for example, WRED) to the Internet infrastructure, routers are no longer limited to packet loss as an indication of congestion.



Note You cannot use this feature when you have set qos-group or mpls experimental along with a traffic class in the ingress policy.

Implementing ECN

Implementing ECN requires an ECN-specific field that has 2 bits—the ECN-capable Transport (ECT) bit and the CE (Congestion Experienced) bit—in the IP header. The ECT bit and the CE bit can be used to make four ECN field combinations of 00 to 11. The first number is the ECT bit and the second number is the CE bit.

Table 32: ECN Bit Setting

ECT Bit	CE Bit	Combination Indicates
0	0	Not-ECN-capable.
0	1	Endpoints of the transport protocol are ECN-capable.
1	0	Endpoints of the transport protocol are ECN-capable.
1	1	Congestion experienced.

The ECN field combination 00 indicates that a packet is not using ECN. The ECN field combinations 01 and 10—Called ECT(1) and ECT(0), respectively—are set by the data sender to indicate that the endpoints of the transport protocol are ECN-capable. Routers treat these two field combinations identically. Data senders can

use either one or both of these two combinations. The ECN field combination 11 indicates congestion to the endpoints. Packets arriving a full queue of a router will be dropped.

Packet Handling When ECN Is Enabled

When the number of packets in the queue is below the minimum threshold, packets are transmitted.

If the number of packets in the queue is above the maximum threshold:

- For traffic flows that are not ECN-enabled in only WRED-configured queues, packets are tail-dropped after the queue size exceeds the WRED maximum threshold.
- For traffic flows that are ECN-enabled in only WRED-configured queues, packets are tail-dropped when the queue size exceeds the tail-drop threshold.
- When you configure ECN remarking on your router, incoming packets with ECT bit settings 0 or 1 are marked as CE.

For Layer 3-to-Layer 2 traffic flows in BVI 2-pass mode on routers that have the NC57 line card installed and operating in the native mode:

- ECN remarking to 11 is not supported for ECN-capable flows [ECT(0) or ECT(1)].
- ECN-capable flows on a WRED-enabled queue are subject to WRED processing. The queue starts tail-dropping once it reaches the WRED max threshold.



Note When the number of packets reaches the queue limit, all packets are dropped. This is the identical treatment that a packet receives when you enable WRED without ECN configured on the router.

Three different scenarios arise if the number of packets in the queue is between the minimum threshold and the maximum threshold:

- If the ECN field on the packet indicates that the endpoints are ECN-capable (that is, the ECT bit is set to 1 and the CE bit is set to 0, or the ECT bit is set to 0 and the CE bit is set to 1)—and the WRED algorithm determines that the packet should have been dropped based on the drop probability—the ECT and CE bits for the packet are changed to 1, and the packet is transmitted. This happens because ECN is enabled and the packet gets marked instead of dropped.
- If the ECN field on the packet indicates that neither endpoint is ECN-capable (that is, the ECT bit is set to 0 and the CE bit is set to 0), packet is dropped once the queue limit is reached.
- If the ECN field on the packet indicates that the network is experiencing congestion (that is, both the ECT bit and the CE bit are set to 1), the packet is transmitted. No further marking is required.



Note Applicable until Cisco IOS XR Release 7.11.1: When the incoming IP traffic with ECN bits set to 10 passes through the ingress qos-policy-map that has the class-map definition of `set DSCP/PREC <value>`, then the ECN bits in the IP header gets modified to 01. This is applicable to NC57 routers operating in the Native mode.

Applicable from Cisco IOS XR Release 7.11.2 : NC57 line cards operating in compatibility mode do not support ECN-bit preservation for terminated VXLAN packets when you configure ACL compression for ingress traffic.

Limitations

- For release 24.1.2 and later, NC57 line cards operating in compatibility mode do not support ECN bit preservation for terminated VXLAN packets when ACL compression is configured for ingress traffic.
- ECN configuration is not supported per discard class but for all packets enqueued to a VOQ.

- **The following limitation is not applicable to NC57 routers:**

SRv6 Disposition Node — For the incoming traffic that has the outer SRv6 IP header having the ECN bits as non-zero value and the inner IP header ECN bits as zero value, then the ECN bits of the inner IP header will be overwritten to 01.

- Do not enable Explicit Congestion Notification (ECN) and Weighted Random Early Detection (WRED) at the same time. So, do not use the following commands together:

```
*/ ECN Configuration */
Router(config-pmap-c) # random-detect ecn

*/ WRED Configuration */
Router(config-pmap-c) # random-detect discard-class 0 10 ms 500 ms
```

- **The following limitation is specific to NC57 routers operating in Native mode.**



Note ECN remarking functionality is not supported with SRv6 tunnels. The inner header in the following scenario is IP and the outer header is SRv6.

SRv6 Imposition Node — The ECN bits in outer header traffic class is set to 0 when SRv6 encapsulation is set to traffic-class propagate along with Ingress MQC set to any DSCP/PREC value. This scenario does not impact the inner header ECN bits.

SRv6 Disposition Node — The ECN bits in the inner packet header is reset to 0 when the Ingress MQC is set to any DSCP/PREC value.

Configuration Example

```
Router# configure
Router(config)# policy-map policy1
Router(config-pmap)# class class1
Router(config-pmap-c)# bandwidth percent 50
Router(config-pmap-c)# random-detect 1000 packets 2000 packets
Router(config-pmap-c)# random-detect ecn
Router(config-pmap-c)# exit
```

```
Router(config-pmap)# exit
Router(config)# commit
```

Verification

Use the **show policy-map interface** to verify the configuration.

```
Router# show policy-map interface tenGigE 0/0/0/6 output
TenGigE0/0/0/6 output: pm-out-queue

Class cm-tc-1
  Classification statistics          (packets/bytes)      (rate - kbps)
  Matched                          :          85528554/87581239296      4830672
  Transmitted                       :          16240891/16630672384      966585
  Total Dropped                     :          69287663/70950566912      3864087
  Queueing statistics
  Queue ID                          :          1113
  Taildropped (packets/bytes)       :          69287663/70950566912

  WRED profile for
  RED Transmitted (packets/bytes)    : N/A
  RED random drops (packets/bytes)  : N/A
  RED maxthreshold drops (packets/bytes) : N/A
  RED ecn marked & transmitted (packets/bytes) : N/A
Class class-default
  Classification statistics          (packets/bytes)      (rate - kbps)
  Matched                          :              0/0              0
  Transmitted                       :              0/0              0
  Total Dropped                     :              0/0              0
  Queueing statistics
  Queue ID                          :          1112
  Taildropped (packets/bytes)       :              0/0
```



Note No ECN-specific statistics are displayed in the show output for this command. ECN is enabled if all rows indicate **N/A**, as highlighted in the example.

From Cisco IOS XR Release 7.5.4, you can enable the display of ECN-marked packets. See [Statistics for ECN-Marked Packets, on page 134](#).

Statistics for ECN-Marked Packets

Table 33: Feature History Table

Feature Name	Release Information	Feature Description
Statistics for ECN-Marked Packets	Release 7.5.4	<p>By enabling the counters for ECN-marked and transmitted packets, we equip you with the ability to determine the exact congestion point in your network and tweak your network design and traffic profiles accordingly.</p> <p>Earlier releases didn't support counters for ECN-marked and transmitted packets.</p> <p>This functionality introduces the following options to enable viewing the counters:</p> <ul style="list-style-type: none"> • YANG data model: <code>Cisco-IOS-XR-fa-hw-profile-dg.yang</code> (see Github, YANG Data Models Navigator) • CLI: <code>hw-module profile qos ecn-marking-stats</code>

In earlier releases, while you could enable ECN to mark packets and manage packet congestion, you had no insights into the number of ECN-marked and transmitted packets. This meant that while you knew that packets were ECN-marked—that is, there was congestion—you couldn't say precisely where in the network it was happening and how much congestion was occurring at each node.

With Cisco IOS XR Release 7.5.4, you can enable the counters for ECN-marked and transmitted packets. With this information, you now know the extent of packet congestion and can determine the exact congestion point in your network and adjust your traffic profiles accordingly.

Statistics for ECN-Marked Packets: Guidelines and Limitations

- This feature is only supported on the following line cards and fixed chassis PIDs of the NCS5500 Series:
 - NC55-36X100G
 - NC55-18H18F
 - NC55-24X100G-SE
 - NC55-36X100G-S
 - NC55-24H12F-SE
 - NC55-36X100G-A-SE
 - NCS-55A1-36H-SE-S

- NCS-55A1-36H-S
- NCS-55A1-24H
- NCS-55A1-48Q6H
- When you enable this feature, egress ACL actions will not be supported.
- The number of ECN classes you can enable for statistics is restricted to 120.
- ECN statistics are only supported for egress policies applied on the main interfaces of physical ports or link bundles.

Configure to Enable Statistics for ECN-Marked Packets

To enable the viewing of statistics for ECN-Marked Packets, configure the **hw-module profile qos ecn-marking-stats** command.

```
Router#config
Router(config)#hw-module profile qos ecn-marking-stats
In order to activate this profile, you must manually reload the chassis/all line cards
Router(config)#commit
```



Note The router must be reloaded for the hw-module command to be functional.

Verification

Run the **show policy-map interface** command to view the details about ECN-marked packets.

```
Router#show policy-map interface tenGigE 0/0/0/6 output
TenGigE0/0/0/6 output: pm-out-queue
Class tc2
  Classification statistics          (packets/bytes)      (rate - kbps)
  Matched                          :      8102473/1037116544      0
  Transmitted                       :      5795588/741835264      0
  Total Dropped                     :      2306885/295281280      0
  Queueing statistics
  Queue ID                          :      1026
  Taildropped (packets/bytes)       :      2306885/295281280
  WRED profile for Discard Class 0
  RED Transmitted (packets/bytes)   :      N/A
  RED random drops (packets/bytes)  :      N/A
  RED maxthreshold drops (packets/bytes) :      N/A
  RED ecn marked & transmitted (packets/bytes) : 6193754/836156790
  RED profile (default)
  RED Transmitted (packets/bytes)   :      N/A
  RED random drops (packets/bytes)  :      N/A
  RED maxthreshold drops (packets/bytes) :      N/A
```

Configure ECN Maximum Marking Probability

Table 34: Feature History Table

Feature Name	Release Information	Feature Description
Configure ECN Maximum Marking Probability	Release 7.3.3	<p>This feature allows you to configure percentages for ECN maximum marking probability after considering your network congestion and end-to-end application needs. With this flexibility, you can fine-tune the network's reactivity to congestion according to the tolerance levels of your end-to-end applications.</p> <p>By controlling the probability of packets being ECN marked at the ECN maximum threshold, you can optimize the congestion notification from the traffic destination to the traffic source. This optimization avoids aggressive throttling at the source (from too high ECN maximum marking probability) or traffic drops in transit due to significantly less throttling at the source (from too low ECN maximum marking probability).</p> <p>This functionality modifies the existing random-detect command.</p>

- **First, something about packet drop probability and Explicit Congestion Notification (ECN)**—The probability that a packet will be ECN-marked is based on the minimum threshold, maximum threshold, and maximum mark probability percent.

When the average queue size is above the minimum threshold, ECN starts marking packets to indicate congestion. When an ECN-marked packet reaches the end host, the host transmits confirmation of receipt of this packet to the transmitting host. The confirmation indicates to the transmitting host that congestion has begun and that the transmission or packet rate must be reduced.

Maximum mark probability is the percentage of packets marked when the average queue size is at the maximum threshold. The ECN mark probability increases linearly from 0 when queue length is less than minimum threshold to 10% when the queue length equals or exceeds the maximum threshold. For example, when the average queue size is halfway between minimum-threshold and maximum-threshold the mark probability is 5%, and half the packets transmitted will be ECN marked.

- **Configurable ECN Maximum Marking Probability**—So far, the ECN maximum marking probability was not user-configurable and was fixed at 10%. The arrangement of preset marking probabilities meant that the router couldn't adapt the congestion notification to network characteristics and application tolerance. With the flexibility to configure maximum ECN marking probability, you can configure the

maximum marking probability to a higher or lower percent, depending on the requirements of congestion handling in the network for a given traffic flow and application type. This also allows you to choose a consistent ECN maximum marking probability across all network elements instead of operating them at the factory default values. The following table maps the linear increase in mark probability percentage as the queue length conditions change from 0 to the tail drop threshold.

Queue length conditions	Mark probability increases linearly...
Queue length is less than the minimum threshold value	from 0
Average queue length is between minimum-threshold and maximum-threshold	corresponding to the average queue length: $(\text{maximum mark probability}) * (\text{average queue length} - \text{minimum threshold value}) / (\text{maximum threshold value} - \text{minimum threshold value})$
Queue length equals the maximum threshold	to the configured maximum probability percentage
maximum threshold value < queue length < tail drop threshold	to 100%

• Some FAQs

• What if I set the ECN marking probability percentage to 10%?

In such a case, there's no change in traffic behavior from what it was for previously ECN-marked packets. Tail drop comes into play when the queue length exceeds the tail drop threshold.

• How does traffic behave beyond my configured value of maximum ECN marking probability?

Let's say you've set the maximum ECN marking probability to 5%. Any more increase in the average queue length beyond maximum ECN threshold shifts the marking probability to 100%, and once the queue length exceeds the tail drop threshold, [Tail Drop and the FIFO Queue, on page 114](#) comes into effect.

• How do I enable this functionality?

Create a policy with **random-detect ecn** and **random-detect** *<min-threshold>* *<max-threshold>* **probability percent** *<value>* configured on an interface.

• How do I disable this functionality?

To disable this functionality, do not configure the **probability percent** value.

• Are the user-configured values programmed precisely in the hardware?

The user-configured values are rounded off to the nearest granularity during programming in the hardware. The round-off is minimal when the 'Pmax/(ECNmax-ECNmin)' ratio is a power of 2, where Pmax is the user-configured maximum marking probability in percent and ECNmin and ECNmax are the user-configured minimum and maximum ECN thresholds.

The **show qos interface** command output displays the actual value programmed in hardware and the user-configured value for reference.

• Important Guidelines

- **Line Cards that support this functionality:**
 - NC55-36X100G
 - NC55-18H18F
 - NC55-24X100G-SE
 - NC55-36X100G-S
 - NC55-24H12F-SE
 - NC55-36X100G-A-SE
 - NCS-55A1-36H-SE-S
 - NCS-55A1-36H-S
 - NCS-55A1-24H
 - NCS-55A1-48Q6H
- **The following interface types** support this functionality:
 - Physical interfaces
 - Bundle interfaces
 - Subinterfaces
 - Bundle subinterfaces
- This functionality is **supported for all interface speeds**.
- If you have a **policy map with one or multiple classes with maximum ECN marking probability enabled**, you can:
 - Apply the map to any of the supported interface types.
 - Remove the map from any of the supported interface types.
 - Modify the map while you're attaching it to multiple interfaces.
- The probability percentage option is supported only with **random-detect ecn** configured in the same class. Else, the policy is rejected when applied on an interface
- **Configuring ECN Maximum Marking Probability**—After you have configured [Explicit Congestion Notification \(ECN\)](#), on page 130, the **random-detect** command displays an option to add the probability in percent.

Configuration Example

```

Router#configure
Router(config)#policy-map policy1
Router(config-pmap)#class class1
Router(config-pmap-c)#bandwidth percent 50
Router(config-pmap-c)#random-detect 1 mbytes 2 mbytes probability percent 5
Router(config-pmap-c)#random-detect ecn
Router(config-pmap-c)#commit

```

Verification

Run the **show qos interface** command to view the configured ECN Maximum Marking Probability value (displayed as **ECN Mark Probability**).

```
Router#sh qos interface FourHundredGigE 0/1/0/4 output
```

NOTE:- Configured values are displayed within parentheses

```
Interface FourHundredGigE0/1/0/4 ifh 0x800150 -- output policy
```

```
-----  
.  
.  
Level2 Class = LOSSLESSTCP_Egress  
Egressq Queue ID = 5475 (LP queue)  
Queue Max. BW. = no max (default)  
Inverse Weight / Weight = 3 / (20)  
Guaranteed service rate = 78329670 kbps  
TailDrop Threshold = 390070272 bytes / 40 ms (default)  
  
Default RED profile  
WRED Min. Threshold = 9787392 bytes (1 ms)  
WRED Max. Threshold = 19580928 bytes (2 ms)  
ECN Mark Probability = 4.99 (5)  
  
WRED ECN = Enabled
```

Configure ECN Maximum Marking Probability



CHAPTER 6

Link Level Flow Control

Link-level Flow Control (LLFC) is a congestion management technique that temporarily pauses data transmission to prevent system overload.

Table 35: Feature History Table

Feature Name	Release Information	Feature Description
LLFC	Release 7.5.1	Link-Level Flow Control (LLFC) helps prevent data loss by managing congestion on network links. By temporarily pausing data transmission when a receiving device becomes congested, LLFC ensures that the network can handle high traffic volumes without dropping packets, maintaining data integrity and performance.

LLFC in network congestion

When a receiving device experiences congestion, it sends a pause frame to the transmitter. Upon receiving this frame, the transmitter temporarily halts data transmission. The LLFC feature affects all traffic on the link and allows separate configuration for transmission and reception. By default, LLFC is disabled in both directions.

- [Guidelines and limitations for link level flow control, on page 141](#)
- [Configure LLFC egress, on page 142](#)
- [Mismatched LLFC configurations, on page 143](#)

Guidelines and limitations for link level flow control

LLFC includes specific configuration guidelines and limitations:

- Ethernet interfaces do not auto detect the LLFC capability. LLFC must be configured explicitly.
- Enabling LLFC requires a part of the buffer to be reserved. This reservation reduces the available shared buffer space.

- Configuration time quanta of the pause frames is not supported.
- On each Ethernet interface, the switch can enable either Priority Flow Control (PFC) or LLFC, but not both. For more information, see [PFC](#).



Note When both PFC and LLFC are enabled, LLFC is selected.

Configure LLFC egress

Follow these steps to configure LLFC egress on an interface.

Procedure

Step 1 Enable the privileged EXEC mode.

```
Device> enable
```

Enter your password if prompted.

Step 2 Enter the global configuration mode.

```
Device# configure terminal
```

Step 3 Enter the **interface** *<Gigabit Ethernet interface>* command to configure an interface type and enter interface configuration mode.

```
Device(config)#interface tenGigE 0/4/0/0
```

Step 4 Enter the **flow-control egress** command to enable the interface to receive and process pause frames.

```
Device(config-if)# flow-control egress
```

- Configuring LLFC on an interface causes the interface to flap which results in a momentary traffic loss.
- The **flow-control** keywords and their expected behaviour:
 - **egress**: Enables the receiving of flow control pause frames.
 - **ingress**: Enables the sending of flow control pause frames (unsupported).
 - **bidirectional**: Enables the receiving of flow control pause frames, but does not allow sending, as ingress flow control is not supported.

Step 5 Enter the **exit** command to exit the interface configuration mode.

```
Device(config-if)# exit
```

Step 6 Verify the **flow-control** configuration with the **show interfaces** *<interface-id>* **flow-control** command.

```
Device# show interfaces tenGigE 0/4/0/0 flow-control
Flow-control Send: off
Flow-control Receive: on
```

Mismatched LLFC configurations

The transmit and receive directions can be configured separately, and each device on the network can have a different LLFC configuration. The table demonstrates the interaction between devices with configurations that do not match.

Switch A	Switch B	Description
LLFC configured to receive and transmit PAUSE frames.	LLFC configured to receive PAUSE frames.	Switch A can transmit 802.3x PAUSE frames and honor 802.3x PAUSE frames. Switch B can only receive 802.3x PAUSE frames.
LLFC configured to receive and transmit PAUSE frames.	LLFC configured to transmit PAUSE frames.	Switch A can transmit 802.3x PAUSE frames and honor 802.3x PAUSE frames. Switch B can transmit 802.3x PAUSE frames but will drop all received PAUSE frames.



CHAPTER 7

Priority Flow Control Overview

Table 36: Feature History Table

Feature Name	Release Information	Feature Description
Priority Flow Control	Release 7.3.2	Previously available in Release 6.6.3, this feature is a link-level flow control mechanism that enables you to selectively pause traffic based on its class of service (CoS).

Priority flow control (PFC; IEEE 802.1Qbb), which is also referred to as Class-based Flow Control (CBFC) or Per Priority Pause (PPP), is a mechanism that prevents frame loss that is due to transient congestion. PFC is similar to 802.3x Flow Control (pause frames) or link-level flow control (LLFC). However, instead of pausing all traffic on a link, PFC functions on a per class-of-service (CoS) basis.

During congestion, PFC sends a pause frame that indicates which CoS value must be paused. When the congestion is mitigated, the router stops sending the PFC frames to the upstream node.

For details about the Priority Flow Control feature, see the *Interface and Hardware Component Configuration Guide for Cisco NCS 5500 Series Routers*.

- [Restrictions, on page 145](#)
- [Configuring Priority Flow Control Thresholds, on page 147](#)
- [View Statistics for Priority Flow Control Buffers, on page 153](#)
- [Priority Flow Control Watchdog Overview, on page 156](#)
- [Configure a Priority Flow Control Watchdog Interval, on page 156](#)
- [Monitoring and Logging Packet Drops on Lossless PFC-Enabled Queues, on page 160](#)

Restrictions

The following restrictions apply while configuring PFC thresholds, PFC watchdog and QoS policies in PFC profile.

- The PFC feature is only supported in the non-HQoS profile.
- The PFC feature is only supported on the following line card or fixed chassis PIDs of the NCS5500 Series:

- NC55-36X100G
 - NC55-18H18F
 - NC55-24X100G-SE
 - NC55-36X100G-S
 - NC55-24H12F-SE
 - NC55-36X100G-A-SE
 - NCS-55A1-36H-SE-S
 - NCS-55A1-36H-S
 - NCS-55A1-24H
 - NCS-55A1-48Q6H
- When PFC is enabled, only two parameter scheduling is supported. So, the egress actions could have either priority or weighted fair queue (WFQ) scheduling apart from a shaper action. For WFQ scheduling, either bandwidth remaining ratio (BRR) or bandwidth is supported and a mix of the two in the same policy-map is rejected. With PFC, BRR has a weight range of 1 to 256 as against 1 to 4096 for the non PFC, non-HQoS case.
 - The hw-module profile for enabling PFC per queue and defining PFC Tx thresholds are global configurations per line card location. So, only one set of pause, resume thresholds and headroom sizes per traffic-class can be configured for all ports on a given line card location. With the introduction of this new configuration model, the pause action under an egress policy class-map is deprecated.
 - While a line card reload is required for any addition or removal of traffic classes in the hw-module profile, you can update the pause, resume thresholds and buffer / headroom sizes on already configured traffic-classes without requiring a line card reload.
 - PFC watchdog (PFCWD) interval has a minimum granularity of 100ms. When you configure higher values, they are rounded up to the nearest multiple of 100ms.
 - There is no XML schema or yang model for the new hw-module profile. Only CLI configuration and show commands are available.
 - In the PFC profile, only monotonically increasing priority levels with traffic-class are supported. For example, TC7 should be p1, TC6 should be p2, and so on, until TC1 is p7 with class-default being lowest priority. Rate classes can be mixed anywhere.
 - When an egress queue is disabled as part of a watchdog queue shutdown action and once the pause frames stop, the queue drains the enqueued packets on the wire while it waits to be restored back.
 - If PFCWD is disabled and a traffic-class experiences sustained PFC storm beyond 7s, then the traffic on that queue continues to be dropped even when the PFC storm stops. Traffic needs to be stopped and restarted or all the incoming ports involved in sending traffic to this egress port needs to be flapped (shut and no shut) to manually recover the egress port.
 - The class-map actions of queue-limit and WRED thresholds without ECN enabled have no impact on PFC-enabled queues. Queue-limit is redundant because packet is buffered based on pause or x-off and headroom configured per source port.

- Even when PFCWD shuts down an egress queue experiencing storm, if the ingress traffic was already causing a congestion due to the application of sub-rate shapers or BRR policy, then the ingress buffers build up and PFC Tx is still generated towards the sender. In other words, PFCWD only removes the source of a storm. It does not suppress PFC Tx generated from sustained congestion due to user configuration.
- In the PFC profile, there is a 25% reduction in available buffer descriptors. Further, 20% of the remaining buffer space is reserved for headroom. This leads to only 80% of the 75% buffers being available in the shared pool for all ingress VoQs on that NP core.

Configuring Priority Flow Control Thresholds

You can set values for pause threshold (x-off), resume threshold (x-on) and headroom for a traffic class on all PFC enabled ports on a given line card location using the hw-module profile priority-flow-control command.

The existing queue-limit for that traffic class on an egress queuing policy on that line card will have no impact and the effective queue limit is pause threshold + headroom.



Note For optimal functionality in hardware, for a given traffic class, the resume threshold should not be more than 10% of the pause threshold and the headroom should be at least 100KB.



Note Due to ASIC errors, some packets may get dropped from the burst traffic. In order to resolve this scenario, flow control is enabled by default on RP to SC link on NCS5500 modular chassis. This will limit the number of packets to be sent on the EPC link from RP card to SC card. This is a default behavior.

For details on how to configure PFC on an interface, see the *Interface and Hardware Component Configuration Guide for Cisco NCS 5500 Series Routers*.

Configuration Example

Apart from the line card level PFC parameters configured through the hw-module profile, PFC Receive functionality requires an egress policy to be applied and egress traffic to be mapped to unique queues per CoS value on all PFC enabled interfaces.

You can accomplish this with the following sequence of configuration.

1. Configure ingress classification policy to map incoming traffic to the right CoS / priority queue.
2. Configure egress queuing policy with the relevant shaping, priority and weighted fair queue scheduling actions
3. Attach the ingress policy on all interfaces where traffic can come in.
4. Attach the egress policy on all PFC enabled interfaces in the system.
5. Configure hw-module priority-flow-control profile and configure pause, resume and headroom for all PFC traffic-classes on all line card locations requiring PFC feature.

Reload the line card for all traffic-class addition and deletions. Parameters within an already configured traffic-class can be edited 'in place' without requiring a line card reload.

Hw-module configuration:

=====

```
RP/0/RP1/CPU0:NCS5504(config)#hw-module profile priority-flow-control location 0/0/CPU0
tRP/0/RP1/CPU0:NCS5504(config-pfc-loc)# traffic-class 3 pause-threshold 403200 bytes
resume-threshold 40320 bytes headroom 441600 bytes
RP/0/RP1/CPU0:NCS5504(config-pfc-loc)# traffic-class 4 pause-threshold 403200 bytes
resume-threshold 40320 bytes headroom 441600 bytes
RP/0/RP1/CPU0:NCS5504(config-pfc-loc)#
```

Class-map configuration:

=====

```
RP/0/RP1/CPU0:NCS5504(config)#class-map match-any MAIN_IN_CMAP_1
match prRP/0/RP1/CPU0:NCS5504(config-cmap)# match precedence 1
RP/0/RP1/CPU0:NCS5504(config-cmap)# end-class-map
RP/0/RP1/CPU0:NCS5504(config)#!
RP/0/RP1/CPU0:NCS5504(config)#class-map match-any MAIN_IN_CMAP_2
RP/0/RP1/CPU0:NCS5504(config-cmap)# match precedence 2
RP/0/RP1/CPU0:NCS5504(config-cmap)# end-class-map
RP/0/RP1/CPU0:NCS5504(config)#!
RP/0/RP1/CPU0:NCS5504(config)#class-map match-any MAIN_IN_CMAP_3
RP/0/RP1/CPU0:NCS5504(config-cmap)# match precedence 3
RP/0/RP1/CPU0:NCS5504(config-cmap)# end-class-map
RP/0/RP1/CPU0:NCS5504(config)#!
RP/0/RP1/CPU0:NCS5504(config)#class-map match-any MAIN_IN_CMAP_4
RP/0/RP1/CPU0:NCS5504(config-cmap)# match precedence 4
RP/0/RP1/CPU0:NCS5504(config-cmap)# end-class-map
RP/0/RP1/CPU0:NCS5504(config)#!
RP/0/RP1/CPU0:NCS5504(config)#class-map match-any MAIN_IN_CMAP_5
RP/0/RP1/CPU0:NCS5504(config-cmap)# match precedence 5
RP/0/RP1/CPU0:NCS5504(config-cmap)# end-class-map
RP/0/RP1/CPU0:NCS5504(config)#!
RP/0/RP1/CPU0:NCS5504(config)#class-map match-any MAIN_IN_CMAP_6
RP/0/RP1/CPU0:NCS5504(config-cmap)# match precedence 6
RP/0/RP1/CPU0:NCS5504(config-cmap)# end-class-map
RP/0/RP1/CPU0:NCS5504(config)#!
RP/0/RP1/CPU0:NCS5504(config)#class-map match-any MAIN_IN_CMAP_7
RP/0/RP1/CPU0:NCS5504(config-cmap)# match precedence 7
RP/0/RP1/CPU0:NCS5504(config-cmap)# end-class-map
RP/0/RP1/CPU0:NCS5504(config)#!
RP/0/RP1/CPU0:NCS5504(config)#class-map match-any PFC_OUT_CMAP_1
RP/0/RP1/CPU0:NCS5504(config-cmap)# match traffic-class 1
RP/0/RP1/CPU0:NCS5504(config-cmap)# end-class-map
RP/0/RP1/CPU0:NCS5504(config)#!
RP/0/RP1/CPU0:NCS5504(config)#class-map match-any PFC_OUT_CMAP_2
RP/0/RP1/CPU0:NCS5504(config-cmap)# match traffic-class 2
RP/0/RP1/CPU0:NCS5504(config-cmap)# end-class-map
RP/0/RP1/CPU0:NCS5504(config)#!
RP/0/RP1/CPU0:NCS5504(config)#class-map match-any PFC_OUT_CMAP_3
RP/0/RP1/CPU0:NCS5504(config-cmap)# match traffic-class 3
RP/0/RP1/CPU0:NCS5504(config-cmap)# end-class-map
RP/0/RP1/CPU0:NCS5504(config)#!
RP/0/RP1/CPU0:NCS5504(config)#class-map match-any PFC_OUT_CMAP_4
RP/0/RP1/CPU0:NCS5504(config-cmap)# match traffic-class 4
RP/0/RP1/CPU0:NCS5504(config-cmap)# end-class-map
RP/0/RP1/CPU0:NCS5504(config)#!
RP/0/RP1/CPU0:NCS5504(config)#class-map match-any PFC_OUT_CMAP_5
RP/0/RP1/CPU0:NCS5504(config-cmap)# match traffic-class 5
RP/0/RP1/CPU0:NCS5504(config-cmap)# end-class-map
RP/0/RP1/CPU0:NCS5504(config)#!
RP/0/RP1/CPU0:NCS5504(config)#class-map match-any PFC_OUT_CMAP_6
RP/0/RP1/CPU0:NCS5504(config-cmap)# match traffic-class 6
```

```
RP/0/RP1/CPU0:NCS5504(config-cmap)# end-class-map
RP/0/RP1/CPU0:NCS5504(config)#!
RP/0/RP1/CPU0:NCS5504(config)#class-map match-any PFC_OUT_CMAP_7
RP/0/RP1/CPU0:NCS5504(config-cmap)# match traffic-class 7
RP/0/RP1/CPU0:NCS5504(config-cmap)# end-class-map
RP/0/RP1/CPU0:NCS5504(config)#!
RP/0/RP1/CPU0:NCS5504(config)#
```

Ingress Policy-map configuration:

```
=====
RP/0/RP1/CPU0:NCS5504(config)#policy-map MAIN_OUT_TC_SUPPORTING_UUT
RP/0/RP1/CPU0:NCS5504(config-pmap)# class MAIN_IN_CMAP_1
RP/0/RP1/CPU0:NCS5504(config-pmap-c)# set traffic-class 1
RP/0/RP1/CPU0:NCS5504(config-pmap-c)# !
RP/0/RP1/CPU0:NCS5504(config-pmap-c)# class MAIN_IN_CMAP_2
RP/0/RP1/CPU0:NCS5504(config-pmap-c)# set traffic-class 2
RP/0/RP1/CPU0:NCS5504(config-pmap-c)# !
RP/0/RP1/CPU0:NCS5504(config-pmap-c)# class MAIN_IN_CMAP_3
RP/0/RP1/CPU0:NCS5504(config-pmap-c)# set traffic-class 3
RP/0/RP1/CPU0:NCS5504(config-pmap-c)# !
RP/0/RP1/CPU0:NCS5504(config-pmap-c)# class MAIN_IN_CMAP_4
RP/0/RP1/CPU0:NCS5504(config-pmap-c)# set traffic-class 4
RP/0/RP1/CPU0:NCS5504(config-pmap-c)# !
RP/0/RP1/CPU0:NCS5504(config-pmap-c)# class MAIN_IN_CMAP_5
RP/0/RP1/CPU0:NCS5504(config-pmap-c)# set traffic-class 5
RP/0/RP1/CPU0:NCS5504(config-pmap-c)# !
RP/0/RP1/CPU0:NCS5504(config-pmap-c)# class MAIN_IN_CMAP_6
RP/0/RP1/CPU0:NCS5504(config-pmap-c)# set traffic-class 6
RP/0/RP1/CPU0:NCS5504(config-pmap-c)# !
RP/0/RP1/CPU0:NCS5504(config-pmap-c)# class MAIN_IN_CMAP_7
RP/0/RP1/CPU0:NCS5504(config-pmap-c)# set traffic-class 7
RP/0/RP1/CPU0:NCS5504(config-pmap-c)# !
RP/0/RP1/CPU0:NCS5504(config-pmap-c)#
RP/0/RP1/CPU0:NCS5504(config-pmap-c)#
```

Egress policy-map configuration:

```
=====
RP/0/RP1/CPU0:NCS5504(config)#policy-map PFC_UUT_bwrr_microsoft
asRP/0/RP1/CPU0:NCS5504(config-pmap)# class PFC_OUT_CMAP_1
RP/0/RP1/CPU0:NCS5504(config-pmap-c)# bandwidth remaining ratio 5
RP/0/RP1/CPU0:NCS5504(config-pmap-c)# queue-limit 192 us
RP/0/RP1/CPU0:NCS5504(config-pmap-c)# !
RP/0/RP1/CPU0:NCS5504(config-pmap-c)# class PFC_OUT_CMAP_2
RP/0/RP1/CPU0:NCS5504(config-pmap-c)# bandwidth remaining ratio 5
RP/0/RP1/CPU0:NCS5504(config-pmap-c)# queue-limit 192 us
RP/0/RP1/CPU0:NCS5504(config-pmap-c)# !
RP/0/RP1/CPU0:NCS5504(config-pmap-c)# class PFC_OUT_CMAP_3
RP/0/RP1/CPU0:NCS5504(config-pmap-c)# bandwidth remaining ratio 20
RP/0/RP1/CPU0:NCS5504(config-pmap-c)# random-detect ecn
RP/0/RP1/CPU0:NCS5504(config-pmap-c)# random-detect 224 kbytes 275 kbytes
RP/0/RP1/CPU0:NCS5504(config-pmap-c)# !
RP/0/RP1/CPU0:NCS5504(config-pmap-c)# class PFC_OUT_CMAP_4
RP/0/RP1/CPU0:NCS5504(config-pmap-c)# bandwidth remaining ratio 20
RP/0/RP1/CPU0:NCS5504(config-pmap-c)# random-detect ecn
RP/0/RP1/CPU0:NCS5504(config-pmap-c)# random-detect 224 kbytes 275 kbytes
RP/0/RP1/CPU0:NCS5504(config-pmap-c)# !
RP/0/RP1/CPU0:NCS5504(config-pmap-c)# class PFC_OUT_CMAP_5
RP/0/RP1/CPU0:NCS5504(config-pmap-c)# bandwidth remaining ratio 20
RP/0/RP1/CPU0:NCS5504(config-pmap-c)# queue-limit 192 us
RP/0/RP1/CPU0:NCS5504(config-pmap-c)# !
RP/0/RP1/CPU0:NCS5504(config-pmap-c)# class PFC_OUT_CMAP_6
RP/0/RP1/CPU0:NCS5504(config-pmap-c)# bandwidth remaining ratio 1
RP/0/RP1/CPU0:NCS5504(config-pmap-c)# queue-limit 192 us
```

```

RP/0/RP1/CPU0:NCS5504(config-pmap-c)# !
RP/0/RP1/CPU0:NCS5504(config-pmap-c)# class PFC_OUT_CMAP_7
RP/0/RP1/CPU0:NCS5504(config-pmap-c)# shape average percent 10
RP/0/RP1/CPU0:NCS5504(config-pmap-c)# priority level 1
RP/0/RP1/CPU0:NCS5504(config-pmap-c)# queue-limit 192 us
RP/0/RP1/CPU0:NCS5504(config-pmap-c)# !
RP/0/RP1/CPU0:NCS5504(config-pmap-c)# class class-default
RP/0/RP1/CPU0:NCS5504(config-pmap-c)# bandwidth remaining ratio 20
RP/0/RP1/CPU0:NCS5504(config-pmap-c)# queue-limit 192 us
RP/0/RP1/CPU0:NCS5504(config-pmap-c)# !

```

Applying policy to ingress and egress interface:

```

=====
RP/0/RP1/CPU0:NCS5504#show running-config interface hundredGigE 0/0/0/0
interface HundredGigE0/0/0/0
  service-policy input MAIN_OUT_TC_SUPPORTING_UUT
  ipv4 address 100.1.9.1 255.255.255.0
  ipv6 address 100:1:9::1/96
  priority-flow-control mode on

interface HundredGigE0/1/0/19
  service-policy output PFC_ECN_UUT_bwrr_microsoft
  ipv4 address 10.1.9.1 255.255.255.0
  ipv6 address 10:1:9::1/96
  priority-flow-control mode on
!

```

Running Configuration

```

RP/0/RP1/CPU0:NCS5504# show running-config hw-module profile priority-flow-control location
 0/0/CPU0
Tue Oct 13 10:31:58.035 UTC
hw-module profile priority-flow-control location 0/0/CPU0
traffic-class 3 pause-threshold 403200 bytes resume-threshold 40320 bytes headroom 441600
bytes
traffic-class 4 pause-threshold 403200 bytes resume-threshold 40320 bytes headroom 441600
bytes
!

```

```

RP/0/RP1/CPU0:NCS5504#show running-config class-map
Tue Oct 13 10:32:02.400 UTC
class-map match-any MAIN_IN_CMAP_1
match precedence 1
end-class-map
!
class-map match-any MAIN_IN_CMAP_2
match precedence 2
end-class-map
!
class-map match-any MAIN_IN_CMAP_3
match precedence 3
end-class-map
!
class-map match-any MAIN_IN_CMAP_4
match precedence 4
end-class-map
!
class-map match-any MAIN_IN_CMAP_5
match precedence 5
end-class-map
!
class-map match-any MAIN_IN_CMAP_6
match precedence 6
end-class-map

```

```
!
class-map match-any MAIN_IN_CMAP_7
match precedence 7
end-class-map
!
class-map match-any PFC_OUT_CMAP_1
match traffic-class 1
end-class-map
!
class-map match-any PFC_OUT_CMAP_2
match traffic-class 2
end-class-map
!
class-map match-any PFC_OUT_CMAP_3
match traffic-class 3
end-class-map
!
class-map match-any PFC_OUT_CMAP_4
match traffic-class 4
end-class-map
!
class-map match-any PFC_OUT_CMAP_5
match traffic-class 5
end-class-map
!
class-map match-any PFC_OUT_CMAP_6
match traffic-class 6
end-class-map
!
class-map match-any PFC_OUT_CMAP_7
match traffic-class 7
end-class-map
!

RP/0/RP1/CPU0:NCS5504#show running-config policy-map PFC_UUT_bwrr_microsoft
Tue Oct 13 10:32:18.009 UTC
policy-map PFC_UUT_bwrr_microsoft
class PFC_OUT_CMAP_1
bandwidth remaining ratio 5
queue-limit 192 us
!
class PFC_OUT_CMAP_2
bandwidth remaining ratio 5
queue-limit 192 us
!
class PFC_OUT_CMAP_3
bandwidth remaining ratio 20
random-detect ecn
random-detect 224 kbytes 275 kbytes
!
class PFC_OUT_CMAP_4
bandwidth remaining ratio 20
random-detect ecn
random-detect 224 kbytes 275 kbytes
!
class PFC_OUT_CMAP_5
bandwidth remaining ratio 20
queue-limit 192 us
!
class PFC_OUT_CMAP_6
bandwidth remaining ratio 1
queue-limit 192 us
!
class PFC_OUT_CMAP_7
```

```

shape average percent 10
priority level 1
queue-limit 192 us
!
class class-default
bandwidth remaining ratio 20
queue-limit 192 us
!
end-policy-map
!

RP/0/RP1/CPU0:NCS5504#show running-config policy-map MAIN_OUT_TC_SUPPORTING_UUT
Tue Oct 13 10:32:31.430 UTC
policy-map MAIN_OUT_TC_SUPPORTING_UUT
class MAIN_IN_CMAP_1
set traffic-class 1
!
class MAIN_IN_CMAP_2
set traffic-class 2
!
class MAIN_IN_CMAP_3
set traffic-class 3
!
class MAIN_IN_CMAP_4
set traffic-class 4
!
class MAIN_IN_CMAP_5
set traffic-class 5
!
class MAIN_IN_CMAP_6
set traffic-class 6
!
class MAIN_IN_CMAP_7
set traffic-class 7
!
class class-default
!
end-policy-map
!
```

Verification

Incoming PFC frames are displayed on the PFC Rx statistics that are shown in the command below. If the interface is enabled for PFC and has an egress queuing policy applied to it, then the queue corresponding to the incoming CoS value on the PFC frames is paused.

When PFC pause thresholds are crossed, PFC Tx frames are sent out of the PFC enabled interfaces sourcing such traffic on that network processing core. This can be verified against the PFC Tx statistics that are shown on this command. After the congestion condition ceases and the buffer resource usage goes below the PFC resume thresholds, a PFC resume frame is sent and the PFC Tx frames are stopped.

```

RP/0/RP1/CPU0:NCS5504#show controllers hundredGigE 0/0/0/0 priority-flow-control statistics
Mon Oct 12 12:22:39.362 UTC

Priority flow control information for interface HundredGigE0/0/0/0:

Priority Flow Control:
  Total Rx PFC Frames: 0
  Total Tx PFC Frames: 1764273
  Rx Data Frames Dropped: 0
```

```

CoS  Status  Rx Frames  Tx Frames
----  -
0    off     0          0
1    off     0          0
2    off     0          0
3    on      0          882032
4    on      0          882241
5    off     0          0
6    off     0          0
7    off     0          0

```

The status of the traffic-class and the configured parameters under it on the hw-module priority-flow-control profile can be checked using the following command.

```
RP/0/RP1/CPU0:NCS5504#show controllers npu priority-flow-control loc 0/0/CPU0
Mon Oct 12 14:35:17.531 UTC
```

```

Location:      0/0/CPU0
PFC:           Enabled
TC    Pause-threshold  Resume-Threshold  Headroom
-----
3     403200 bytes     40320 bytes       441600 bytes
4     403200 bytes     40320 bytes       441600 bytes

```

View Statistics for Priority Flow Control Buffers

Table 37: Feature History Table

Feature Name	Release Information	Feature Description
View Statistics for Priority Flow Control Buffers	Release 7.5.4	<p>You can now capture critical information for PFC-enabled ports about instantaneous buffer occupancy, threshold buffer values, and PFC configuration parameters, as programmed in the hardware. You can submit this information to us to help you debug your issues effectively.</p> <p>This functionality introduces the following:</p> <ul style="list-style-type: none"> • YANG Data Model (at Github under the 754 folder): <code>Cisco-IOS-XR-ncs5500-qos-oper.yang</code> • CLI: <code>show controllers npu priority-flow-control vsq-usage</code>

With Cisco IOS XR Release 7.5.4, you can capture critical information for PFC-enabled ports that you can submit to us to help you debug your issues. This information includes values for instantaneous buffer occupancy and buffer threshold, and some key PFC parameters.

Run the **show controllers npu priority-flow-control vsq-usage** command to view the following details:

- The buffer threshold values (in bytes) for a traffic class:
 - **Pause-threshold:** the buffer threshold at which PFC sends a pause frame.
 - **Resume-threshold:** the buffer threshold at which the packets resume their flow.
 - **Headroom:** the headroom (or reserved buffer) size

The output also displays a unique ID (**pg_vsq_id**) that maps to a traffic class. This is the resource ID for the PFC-enabled queue corresponding to the configured traffic class in the hardware.

- **VSQ Occupancy Information:** The instantaneous buffer occupancy values for the traffic class. (Buffer occupancy indicates the amount of data frames stored in the buffer at any given time when the traffic is flowing.) For convenience, the values include buffer occupancy information for a given traffic class in two different units across both the headroom and shared pool buffers:
 - The buffer descriptor (BD) values— fixed length memory units consumed for a given memory type.
 - Bytes—the actual size of memory used up to queue packets in each pool.
- **Available Buffers:** The total available ingress buffer space for each core.
- **Ingress Reject Reason:** The reason for ingress packets being rejected from being enqueued in the VOQ.

Verification

```
Router#show controllers npu priority-flow-control vsq-usage interface hundredGigE 0/0/1/0
location 0/0/CPU0
```

```
Location          : 0/0/CPU0
Intf Handle (Hex) : a8
Core              : 0
Npu_id           : 0
pp_port          : 21
```

```
VSQ Threshold Information:
=====
```

TC	Pause-threshold Bytes	Resume-threshold Bytes	Headroom Bytes	pg_vsq_id
3	405504	40192	442368	12
4	405504	40192	442368	13

```
VSQ Occupancy Information:
=====
```

TC	pg_vsq_id	Headroom BDs	Shared Pool BDs	Headroom Bytes	Shared Pool Bytes
3	12	0	0	0	0
4	13	0	0	0	0

```
Available Buffers:
=====
```

```
OCB      : On chip buffer
MNMC     : Mini multicast buffer
FMC      : Full multicast buffer
```

core	OCB		MNMC		FMC	
	Buffers	Percent	Buffers	Percent	Buffers	Percent
0	32768	100	786432	100	98304	100
1	32768	100	1310720	100	98304	100

Ingress Reject Reason:

=====

Packet Reject Bitmap (Core 0):

Reg_val0 : 0

Reg_val1 : 0

Packet Reject Bitmap (Core 1):

Reg_val0 : 0

Reg_val1 : 0

core Bit_Pos Reason

```
-----
      None
      None
```

```
Location           : 0/0/CPU0
Intf Handle(Hex)   : 48
Core               : 0
Npu_id            : 0
pp_port           : 9
```

VSQ Threshold Information:

=====

TC	Pause-threshold Bytes	Resume-threshold Bytes	Headroom Bytes	pg_vsq_id
3	405504	40192	442368	20
4	405504	40192	442368	21

VSQ Occupancy Information:

=====

TC	pg_vsq_id	Headroom BDs	Shared Pool BDs	Headroom Bytes	Shared Pool Bytes
3	20	0	0	0	0
4	21	0	0	0	0

Available Buffers:

=====

```
OCB      : On chip buffer
MNMC     : Mini multicast buffer
FMC      : Full multicast buffer
```

core	OCB		MNMC		FMC	
	Buffers	Percent	Buffers	Percent	Buffers	Percent
0	32768	100	786432	100	98304	100
1	32768	100	1310720	100	98304	100

```

Ingress Reject Reason:
=====
Packet Reject Bitmap (Core 0):
Reg_val0 : 0
Reg_val1 : 0

Packet Reject Bitmap (Core 1):
Reg_val0 : 0
Reg_val1 : 0

core   Bit_Pos   Reason
-----
      None
      None

```

View Statistics for Priority Flow Control Buffers: Guidelines

- There may be a slight variation in the values you configure for PFC and the displayed values for the **show controllers npu priority-flow-control vsq-usage** command. This variation is because of the rounding-off of the values as programmed in the hardware.

Priority Flow Control Watchdog Overview

PFC Watchdog is a mechanism to identify any PFC storms (queue-stuck condition) in the network, and to prevent the PFC from propagating on the network and running in a loop. You can configure a PFC watchdog interval to detect whether packets in a no-drop queue are being drained within a specified time period. When the time period is exceeded, all outgoing packets are dropped on interfaces that match the PFC queue that is not being drained.

This requires monitoring PFC receiving on each port and detecting ports seeing an unusual amount of sustained pause frames. Once detected, the watchdog module can enforce several actions on such ports, which include generating a syslog message for network management systems, shutting down the queue, and auto-restoring the queue (after the PFC storm stops).

Related Topics

- [Priority Flow Control Overview, on page 145](#)

Configure a Priority Flow Control Watchdog Interval

You can configure PFC Watchdog parameters (Watchdog interval, shutdown multiplier, auto-restore multiplier) at the global or interface levels. Note that:

- When global Watchdog mode is disabled or off, Watchdog is disabled on all interfaces. This condition is regardless of the interface level Watchdog mode settings.
- When global Watchdog mode is enabled or on, the interface level Watchdog mode configuration settings override the global Watchdog mode values.
- When you configure interface level Watchdog attributes such as interval, shutdown multiplier, and auto-restore multiplier, they override the global Watchdog attributes.



Note Configuring the PFC mode and its policies is a prerequisite for PFC Watchdog.



Note PFC Watchdog also monitors, detects, and generates a syslog message every 5 minutes if global pause frames or link level flow control frames are received on a PFC-enabled port.

Such frames are ignored and discarded on the PFC-enabled port.

Configuration Example

You can configure the Watchdog at the global or at the interface level.



Note Watchdog is enabled by default, with system default values of:

Watchdog interval = 100 ms

Shutdown multiplier = 1

Auto-restore multiplier = 10

```
RP/0/RP1/CPU0:NCS5504# show controllers hundredGigE 0/0/0/0 priority-flow-control
watchdog-config
Mon Oct 12 14:32:47.056 UTC
```

Priority flow control information for interface HundredGigE0/0/0/0:

```
Priority flow control watchdog configuration:
(D) : Default value
U : Unconfigured
```

```
-----
Configuration Item           Global  Interface Effective
-----
PFC watchdog state           :        U        U  Enabled(D)
Poll interval                 :        U        U    100(D)
Shutdown multiplier           :        U        U     1(D)
Auto-restore multiplier       :        U        U    10(D)
```

```
RP/0/RP1/CPU0:NCS5504# show controllers hundredGigE 0/0/0/0 priority-flow-control
watchdog-stat
watchdog-state  watchdog-stats
RP/0/RP1/CPU0:NCS5504# show controllers hundredGigE 0/0/0/0 priority-flow-control
watchdog-state
Mon Oct 12 14:32:56.760 UTC
```

Priority flow control information for interface HundredGigE0/0/0/0:

```
Priority flow control watchdog state machine state:
D - Disabled
M - Monitoring
S - Waiting For Shutdown
R - Waiting to Restore
```

```
-----
PFC Watchdog           : Enabled
```

Configure a Priority Flow Control Watchdog Interval

```

Watchdog SM state : Traffic Class
                   7 6 5 4 3 2 1 0
                   - - - D D - - -
RP/0/RP1/CPU0:NCS5504# show controllers hundredGigE 0/0/0/0 priority-flow-control
watchdog-stats
Mon Oct 12 14:33:09.321 UTC

```

Priority flow control information for interface HundredGigE0/0/0/0:

Priority flow control watchdog statistics:
SAR: Auto restore and shutdown

```

-----
Traffic Class      :      0      1      2      3      4      5      6
                   7
-----
Watchdog Events    :      0      0      0      0      0      0      0
                   0
Shutdown Events    :      0      0      0      0      0      0      0
                   0
Auto Restore Events :      0      0      0      0      0      0      0
                   0
SAR Events         :      0      0      0      0      0      0      0
                   0
SAR Instantaneous Events :      0      0      0      0      0      0      0
                   0
Total Dropped Packets :      0      0      0      0      0      0      0
                   0
Dropped Packets    :      0      0      0      0      0      0      0
                   0
RP/0/RP1/CPU0:NCS5504#

```

```

RP/0/RP1/CPU0:NCS5504#show controllers npu priority-flow-control loc 0/0/CPU0
Mon Oct 12 14:35:17.531 UTC

```

```

Location:      0/0/CPU0
PFC:          Enabled
TC   Pause-threshold   Resume-Threshold   Headroom
-----
3    403200 bytes      40320 bytes       441600 bytes
4    403200 bytes      40320 bytes       441600 bytes
RP/0/RP1/CPU0:NCS5504#

```

```

RP/0/RP1/CPU0:NCS5504#clear controller hundredGigE 0/0/0/0 priority-flow-control
watchdog-stats ?
  traffic-class Traffic class to be cleared
  <cr>
RP/0/RP1/CPU0:NCS5504#clear controller hundredGigE 0/0/0/0 priority-flow-control
watchdog-stats
Mon Oct 12 14:36:12.407 UTC
RP/0/RP1/CPU0:NCS5504#clear controller hundredGigE 0/0/0/0 priority-flow-control
watchdog-stats traffic-class ?
  <0-7> Traffic class
RP/0/RP1/CPU0:NCS5504#clear controller hundredGigE 0/0/0/0 priority-flow-control
watchdog-stats traffic-class 3
NOTE: Use the clear commands to clear the statistics displayed by the show commands.

```

To restore a queue manually that has been shut down by the PFC watchdog action, run the command **set controller <> priority-flow-control recover traffic-class [0-7]**. Completion of this operation resets all internal watchdog state machines and the queue is back to a monitoring state.

```

RP/0/RP1/CPU0:NCS5504#show controllers hundredGigE 0/1/0/19 priority-flow-control
watchdog-state

```

Priority flow control information for interface HundredGigE0/1/0/19:

Priority flow control watchdog state machine state:

D - Disabled
M - Monitoring
S - Waiting For Shutdown
R - Waiting to Restore

PFC Watchdog : Enabled
Watchdog SM state : Traffic Class
7 6 5 4 3 2 1 0
- - - M R - - -
RP/0/RP1/CPU0:NCS5504#

RP/0/RP1/CPU0:NCS5504#set controller hundredGigE 0/1/0/19 priority-flow-control recover traffic-class 3

RP/0/RP1/CPU0:NCS5504#show controllers hundredGigE 0/1/0/19 priority-flow-control watchdog-state

Priority flow control information for interface HundredGigE0/1/0/19:

Priority flow control watchdog state machine state:

D - Disabled
M - Monitoring
S - Waiting For Shutdown
R - Waiting to Restore

PFC Watchdog : Enabled
Watchdog SM state : Traffic Class
7 6 5 4 3 2 1 0
- - - M M - - -

Related Topics

- [Priority Flow Control Overview, on page 145](#)

Monitoring and Logging Packet Drops on Lossless PFC-Enabled Queues

Table 38: Feature History Table

Feature Name	Release Information	Feature Description
Monitoring and Logging Packet Drops on Lossless PFC-Enabled Queues	Release 7.3.2	<p>In case of packet drops on lossless PFC-enabled queues that also have the PFC Watchdog feature enabled, this functionality generates syslogs in 10-minute intervals.</p> <p>Such timely alerts help you troubleshoot quickly, isolate issues, and reroute traffic if necessary, with minimal impact on end-user services.</p>

A Brief Background

Lossless PFC-enabled queues avoid queue tail drops during temporary congestion by sending PFC pause frames back to the previous network element to transmit lesser packets. Depending on the duration of the congestion, the previous network element may send PFC pause frames further upstream, hence triggering subsequent network elements to pause all the way up to the sender. Suppose that the congestion lasts longer or is persistent. In that case, the buffers on some of these network elements may still overflow, causing some packet drops eventually. PFC watchdog isolates such cases of persistent congestion and excessive PFC pause frames. PFC watchdog (enabled by default on all PFC enabled queues) monitors neighboring network elements that send excessive PFC pause frames and shuts down such queues until the PFC storm subsides. This action isolates the issue to just those queues, stops new PFC pause frame generation, and frees up the device buffers for other traffic flows, thus preventing the PFC storm from propagating throughout the network and affecting all other traffic flows.

From IOS XR Release 7.3.2, the PFC watchdog also monitors and periodically reports packet drops that occur due to excessive pausing, congestion, or PFC watchdog-triggered queue shutdown. While the **show controller** commands continue to provide an on-demand display of the total number of packets dropped for a given PFC enabled queue, the new logging mechanism provides timely alerts for proactive user intervention when drops occur on lossless PFC-enabled queues.

Highlights of Logging and Monitoring Packet Drops

From Release 7.3.2 onwards, packet drops on lossless PFC-enabled queues trigger syslogs that record the drop statistics, alerting you about the event. These syslogs enable monitoring of such queues and provide timely updates and alerts that help you take proactive action. You can troubleshoot quickly, isolate issues, and reroute traffic if necessary, with minimal impact on end-user services.

Here are some important highlights of the monitoring and logging of packet drops:

- Only PFC-enabled queues that also have the PFC Watchdog enabled are monitored.

- The syslog generation is event-based, where the event trigger is a packet drop on PFC Watchdog-monitored lossless queue between two consecutive measurement polls at a 10-minute interval. If the drop counters increment between such polls within a 10-minute interval, then this monitoring and logging functionality generates a syslog.
- Syslogs are generated for the following monitored parameters:
 - **Rx Data Frames Dropped** under **show controllers priority-flow-control statistics**. This counter accounts for virtual output queue (VOQ) tail drop statistics from all network processors across all ingress line cards in the system for a given egress port. VOQ tail drops occur when the PFC-enabled lossless queues build up beyond the user-configured headroom.
 - **Dropped Packets** under **show controllers priority-flow-control watchdog statistics**. This parameter accounts for all queue drops on the PFC-enabled lossless queues in the network processor on the egress line card.
- The **show controllers** command continues to display the total number of packets dropped.
- A typical syslog output looks like this:

```
%PLATFORM-PFC_WATCHDOG-5-PACKETDROP : PFC watchdog detected 150 packet drops on lossless  
priority 3 of interface HundredGigE0_7_0_30. Total drops 5678 packets.
```

Restrictions for Monitoring and Logging Packet Drops

The following restrictions apply to the monitoring and logging of packet drops for lossless PFC-enabled queues:

- The 10-minute polling interval is fixed, and you can't modify it.
- The monitoring and logging functionality is enabled by default on all PFC Watchdog-enabled queues, and you can't disable it.



CHAPTER 8

Configuring Modular QoS Congestion Management

This chapter covers the following topics:

- [Congestion Management Overview, on page 163](#)
- [Ingress Traffic Management Model, on page 165](#)
- [Class-based Weighted Fair Queuing, on page 166](#)
- [Low-Latency Queuing with Strict Priority Queuing, on page 169](#)
- [Overhead Accounting, on page 172](#)
- [Traffic Shaping, on page 174](#)
- [4K Pseudowire on Bundle with QoS Enhancement , on page 184](#)
- [Traffic Policing, on page 187](#)
- [Ingress QoS policer scale enhancement using statistics resource reassignment, on page 202](#)
- [Guidelines for configuring ingress QoS policer scale enhancement, on page 203](#)
- [Limitations for configuring ingress QoS policer scale enhancement, on page 204](#)
- [Configure ingress QoS policer scale enhancement using statistics resource reassignment, on page 204](#)
- [References for Modular QoS Congestion Management, on page 207](#)

Congestion Management Overview

Congestion management features allow you to control congestion by determining the order in which a traffic flow (or packets) is sent out an interface based on priorities assigned to packets. Congestion management entails the creation of queues, assignment of packets to those queues based on the classification of the packet, and scheduling of the packets in a queue for transmission.



Note From Cisco IOS XR Release 7.3.1 onwards, systems with Cisco NC57 line cards running in compatibility mode support QoS over Layer 2 services for:

- Local switching [xconnect or bridging]
- L2 VPN – VPWS

Starting with Cisco IOS XR Release 7.4.1 systems with Cisco NC57 line cards running in native mode support QoS over Layer 2 services for:

- Local switching [xconnect or bridging]
- L2 VPN – VPWS

Table 39: Feature History Table

Feature Name	Release Information	Feature Description
Set Peak Burst Size for Egress Shaping	Release 7.4.1	This feature is now supported on routers that have Cisco NC57 line cards installed and operate in native and compatibility modes. With this feature you can configure the burst size along with the existing egress shaper bandwidth, using the " shape average shaper bandwidth burst size burst unit " command. This feature is used to control higher bursts of traffic being transmitted to the devices that have lower queue length configured to receive traffic. For more information, see Configure VOQ-Level Traffic Shaping, on page 175 .
Absolute Rates for Bundle Interfaces for Traffic Shapers and Traffic Policers	Release 7.4.1	This feature is now supported on routers that have Cisco NC57 line cards installed and operate in native and compatibility modes. For more information, see Configure VOQ-Level Traffic Shaping, on page 175 and Configure Traffic Policing (Two-Rate Three-Color), on page 193 .
Ingress Policing on BVI (Bridge Group Virtual Interface) and Low-Latency Queueing (LLQ)	Release 7.4.1	This feature is now supported on routers that have Cisco NC57 line cards installed and operate in native and compatibility modes. For more information, see "Restrictions for QoS on BVI" under Restrictions , on page 79 and Low-Latency Queuing with Strict Priority Queuing, on page 169

The types of traffic regulation mechanisms supported are:

- [Class-based Weighted Fair Queueing, on page 166](#)

- [Low-Latency Queuing with Strict Priority Queuing, on page 169](#)
- [Traffic Shaping, on page 174](#)
- [Traffic Policing, on page 187](#)

Ingress Traffic Management Model

The ingress traffic management model relies on packet queueing on the egress interface using Virtual Output Queueing (VOQ) on the ingress. In this model, buffering takes place at ingress. Here’s how the VOQ process works.

Your routers support up to eight output queues per main interface or physical port. For every egress output queue, the VOQ model earmarks buffer space on every ingress pipeline. This buffer space is in the form of dedicated VOQs. These queues are called virtual because the queues physically exist on the ingress interface only when the line card actually has packets enqueued to it. To support the modular model of packet distribution, each network processing unit (NPU) core at the ingress needs connectors to every egress main interface and subinterface. The ingress traffic management model thus requires a mesh of connectors to connect the ingress NPU cores to the egress interfaces, as shown in **The Ingress Traffic Management Model**.

Figure 5: The Ingress Traffic Management Model

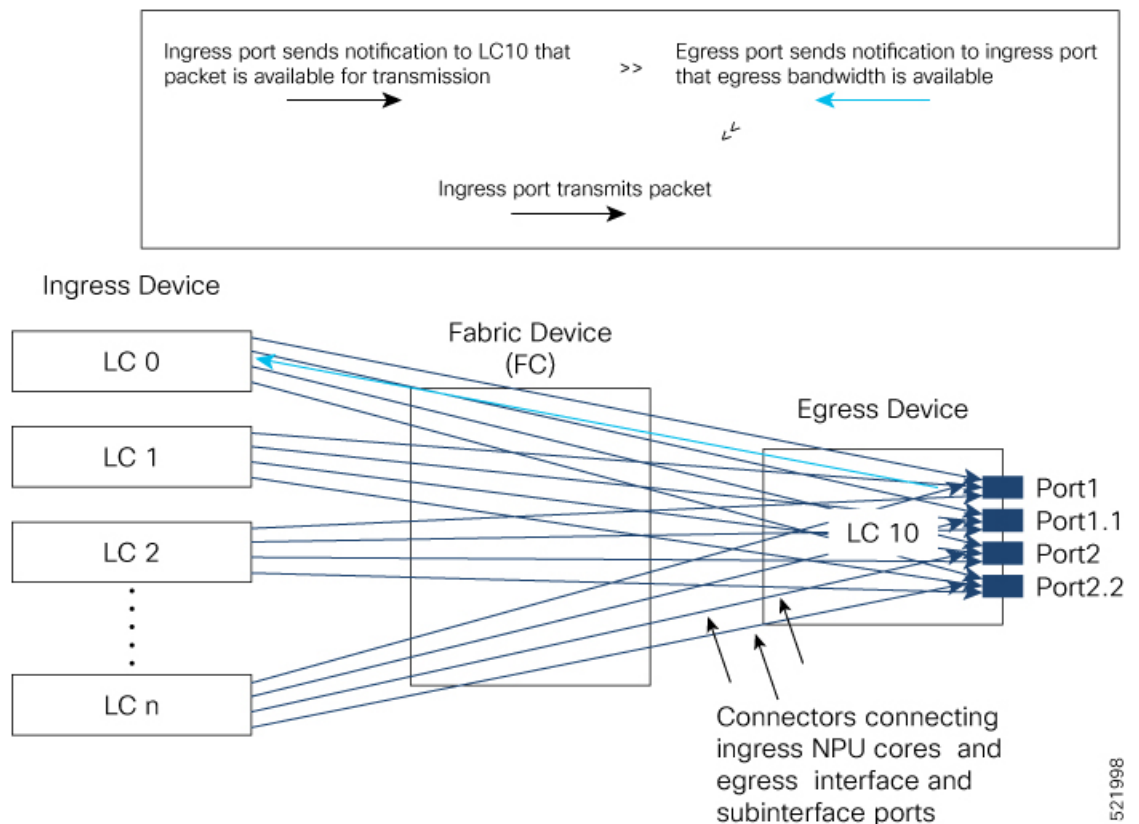

In the figure, every ingress interface (LC 0 through LC n) port has eight VOQs for the single egress line card LC 10.

Here's how packet transmission takes place:

1. When a packet arrives at an ingress port (say on LC 0), the forwarding lookup on the ingress line card points to the egress interface. Based on the egress interface (say it is on LC10), the packet is enqueued to the VOQ of the LC 10 egress port. The egress interface is always mapped to a physical port.
2. Credits are requested from the egress port based on the scheduling mechanism. Once credits are available, the LC 10 will receive the packets (based on the packet marking and distribution model) and send grants to the ingress ports via the connectors. (The figure shows a separate line for the grant for the sake of visual representation. In reality, the same connector is used for requests, grants, and transmission between an NPU core at the ingress and the egress port on LC 10.)
3. The ingress ports respond to this permission by transmitting the packets via FC to the LC 10 ports. (The time it takes for the ingress ports to request for egress port access, the egress port to grant access, and the packet to travel across FC is the round-trip time.)

The VOQ model thus operates on the principle of storing excess packets in buffers at ingress until bandwidth becomes available. Based on the congestion that builds up and the configured threshold values, packets begin to drop at the ingress itself, instead of having to travel all the way to the egress interface and then getting dropped.

Tell me why this doesn't work as expected

Learn about the underlying limitations that lead to unexpected traffic drops, affect shaping behavior, or result in buffer-related constraints.

Why traffic drops occur even below VOQ shaper rate in high-scale QoS

This happens when buffer resources run out in high-scale deployments. If you create over 1,000 Virtual Output Queues (VOQs) with active traffic flows, the router may exhaust its on-chip buffer, resulting in unexpected packet drops.

Why egress queuing statistics are missing for unknown unicast traffic on Cisco NCS 5700 line cards

When unknown unicast traffic is flooded through a bridge domain on routers that have Cisco NCS 5700 series line cards, it is forwarded through the Fabric Multicast Queuing (FMQ) path.

FMQ does not support queuing features or providing queuing statistics at the egress. Egress policies such as shaping do not take effect for this traffic, resulting in null egress statistics. Ingress classification still works as expected.

- Unknown unicast traffic: traffic sent to a destination MAC address that the router doesn't have in its MAC table.
- Fabric multicast queuing path: an internal forwarding path used for multicast, broadcast, and unknown unicast traffic

Class-based Weighted Fair Queueing

Class-based Weighted Fair Queueing (CBWFQ) allows definition of traffic classes based on customer match criteria. With CBWFQ you can define traffic classes and assign guaranteed amount of minimum bandwidth to them. CBWFQ also allows for a strict priority queue for delay-sensitive traffic.

Bandwidth Remaining

The CBWFQ algorithm derives the weight for each class from the bandwidth remaining value allocated to the class. The **bandwidth remaining** option specifies a weight for the class to the CBWFQ. After the priority-queue is serviced, the leftover bandwidth is distributed as per bandwidth remaining ratio (BWRR) or percentage. If you do not configure this command for any class, the default value of the BWRR is considered as 1 (one). In the case of **bandwidth remaining percent**, the remaining bandwidth is equally distributed among other classes, to make it 100 percentage (100%).

Restrictions

- The **bandwidth remaining** command is supported only for egress policies.

Configure Minimum Bandwidth and Bandwidth Remaining

Guidelines

- The **priority** command cannot be configured along with **bandwidth**, **bandwidth remaining** commands, but can be configured with **shaping**, **queue-limit** and **random-detect** commands in the same class. Also see [Restrictions, Limitations, and Requirements for Configuring H-QoS, on page 220](#).

Configuration Example

You have to accomplish the following to complete the minimum bandwidth and bandwidth remaining configuration:

1. Creating or modifying a policy-map that can be attached to one or more interfaces
2. Specifying the traffic class whose policy has to be created or changed
3. Allocating the minimum bandwidth and leftover bandwidth for the class
4. Attaching the policy-map to an output interface

```
Router# configure
Router(config)# policy-map test-bw-bw-rem
Router(config-pmap)# class qos-6
Router(config-pmap-c)# bandwidth percent 60
Router(config-pmap-c)# bandwidth remaining percent 60
Router(config-pmap-c)# exit
Router(config-pmap)# exit
Router(config)# interface HundredGigE 0/6/0/18
Router(config-if)# service-policy output test-bw-bw-rem
Router(config-if)# commit
```

Running Configuration

```
policy-map test-bw-bw-rem
class qos-6
  bandwidth percent 60
  bandwidth remaining percent 60
!
class qos-5
```

```

    bandwidth percent 20
    bandwidth remaining percent 40
    !
class class-default
    !
end-policy-map
!

interface HundredGigE0/6/0/18
    service-policy input 100g-s1-1
    service-policy output test-bw-bw-rem
    !

```

Verification

Router# **show qos interface HundredGigE 0/6/0/18 output**

```

NOTE:- Configured values are displayed within parentheses
Interface HundredGigE0/6/0/18 ifh 0x3000220 -- output policy
NPU Id:                               3
Total number of classes:               3
Interface Bandwidth:                   100000000 kbps
VOQ Base:                              11176
VOQ Stats Handle:                     0x88550ea0
Accounting Type:                       Layer1 (Include Layer 1 encapsulation and above)
-----
Level1 Class                           = qos-6
Egressq Queue ID                       = 11182 (LP queue)
Queue Max. BW.                         = 100824615 kbps (default)
Queue Min. BW.                         = 60494769 kbps (60 %)
Inverse Weight / Weight                 = 2 (60%)
Guaranteed service rate                 = 71881188 kbps
TailDrop Threshold                     = 90177536 bytes / 10 ms (default)
WRED not configured for this class

Level1 Class                           = qos-5
Egressq Queue ID                       = 11181 (LP queue)
Queue Max. BW.                         = 100824615 kbps (default)
Queue Min. BW.                         = 20164923 kbps (20 %)
Inverse Weight / Weight                 = 3 (40%)
Guaranteed service rate                 = 27920792 kbps
TailDrop Threshold                     = 35127296 bytes / 10 ms (default)
WRED not configured for this class

Level1 Class                           = class-default
Egressq Queue ID                       = 11176 (Default LP queue)
Queue Max. BW.                         = 101803495 kbps (default)
Queue Min. BW.                         = 0 kbps (default)
Inverse Weight / Weight                 = 120 (BWR not configured)
Guaranteed service rate                 = 198019 kbps
TailDrop Threshold                     = 247808 bytes / 10 ms (default)
WRED not configured for this class

```

Related Topics

- [Bandwidth Remaining, on page 167](#)

Associated Commands

- [bandwidth](#)
- [bandwidth remaining](#)

Low-Latency Queuing with Strict Priority Queuing

The Low-Latency Queuing (LLQ) feature brings strict priority queuing (PQ) to the CBWFQ scheduling mechanism. Priority queuing (PQ) in strict priority mode ensures that one type of traffic is sent, possibly at the expense of all others. For PQ, a low-priority queue can be detrimentally affected, and, in the worst case, never allowed to send its packets if a limited amount of bandwidth is available or the transmission rate of critical traffic is high.

Configuring Low Latency Queuing with Strict Priority queuing

Configuring low latency queuing (LLQ) with strict PQ allows delay-sensitive data such as voice to be de-queued and sent before the packets in other queues are de-queued.

Support information

Supported priority levels

- Priority levels 1 to 7 are supported, with 1 being the highest and 7 the lowest.
- The default Class of Service Queue (CoSQ) 0 has the lowest priority among all levels.

Profile-based priority support

- For non-H-QoS profiles, priority levels 1 to 7 are supported.
- For H-QoS profiles, only priority levels 1 to 4 are supported.
- Regardless of the profile type, class-default always maps to CoSQ 0, which has the lowest priority.

Queue assignment for priority Level 1

- Any one of the eight egress class-maps (queues) can have priority level 1 configured.

Guidelines

Queue configuration commands

- You can configure these commands along with the **priority** command:
 - **shape average**
 - **queue-limit**
 - **random-detect**

Priority queue oversubscription

- A PQ can oversubscribe bandwidth when other queues do not fully utilize the port bandwidth.

- Oversubscription is supported only for a single priority level.

Limitations

Egress policing

- Egress policing is not supported. Hence, in strict priority queuing scenarios, lower-priority queues may not be serviced if the priority queue consumes the available bandwidth.

Multiple priority level oversubscription

- Bandwidth over-subscription with multiple priority levels is not a supported configuration.
- Starting with Cisco IOS XR Release 7.0.1, if multiple priority levels are configured for oversubscription:
 - the configuration is accepted, and a warning message is displayed
 - fair queuing is applied across all configured priority levels and,
 - higher-priority traffic is not guaranteed precedence over lower-priority traffic.

Traffic Disruption Risk

- There can be minimal traffic disruption when priority level 1 configuration is applied to any of the 8 queues.

Configuration Example

You have to accomplish the following to complete the LLQ with strict priority queuing:

1. Creating or modifying a policy-map that can be attached to one or more interfaces
2. Specifying the traffic class whose policy has to be created or changed.
3. Specifying priority to the traffic class
4. (Optional) Shaping the traffic to a specific bit rate
5. Attaching the policy-map to an output interface

```
Router# configure
Router(config)#class-map qos-1
Router(config-cmap)#match traffic-class 1
Router(config-cmap)#commit

Router(config)#class-map qos-2
Router(config-cmap)#match traffic-class 2
Router(config-cmap)#commit

Router(config)# policy-map test-priority-1
Router(config-pmap)# class qos1
Router(config-pmap-c)# priority level 7
Router(config-pmap-c)# shape average percent 2
Router(config-pmap-c)# class qos-2
Router(config-pmap-c)# priority level 6
Router(config-pmap-c)# shape average percent 1
Router(config-pmap-c)# commit
Router(config-pmap-c)# exit
```

```
Router(config-pmap)# exit

Router(config)# interface HundredGigE 0/0/0/20
Router(config-if)# service-policy output test-priority-1
Router(config-if)# commit
```

Running Configuration

```
policy-map test-priority-1
  class qos-1
    priority level 7
    shape average percent 2
  !
  class qos-2
    priority level 6
    shape average percent 1
  !
  class class-default
  !
end-policy-map
!

interface HundredGigE0/0/0/20
  service-policy output test-priority-1
!
```

Verification

```
Router# show qos int hundredGigE 0/0/0/20 output
```

```
NOTE:- Configured values are displayed within parentheses
Interface HundredGigE0/0/0/20 ifh 0x38 -- output policy
NPU Id: 0
Total number of classes: 3
Interface Bandwidth: 100000000 kbps
Policy Name: test-priority-1
VOQ Base: 1184
Accounting Type: Layer1 (Include Layer 1 encapsulation and above)
-----
Level1 Class (HP7) = qos-1
Egressq Queue ID = 1185 (HP7 queue)
Queue Max. BW. = 2000000 kbps (2 %)
Guaranteed service rate = 2000000 kbps
Peak burst = 36864 bytes (default)
TailDrop Threshold = 2499840 bytes / 10 ms (default)
WRED not configured for this class

Level1 Class (HP6) = qos-2
Egressq Queue ID = 1186 (HP6 queue)
Queue Max. BW. = 1000000 kbps (1 %)
Guaranteed service rate = 1000000 kbps
Peak burst = 36864 bytes (default)
TailDrop Threshold = 1249792 bytes / 10 ms (default)
WRED not configured for this class

Level1 Class = class-default
Egressq Queue ID = 1184 (Default LP queue)
Queue Max. BW. = no max (default)
Queue Min. BW. = 0 kbps (default)
```

```

Inverse Weight / Weight           = 1 / (BWR not configured)
Guaranteed service rate          = 97000000 kbps
Peak burst                        = 36864 bytes (default)
TailDrop Threshold               = 121249792 bytes / 10 ms (default)
WRED not configured for this class

```

Related Topics

- [Congestion Management Overview, on page 163](#)
- [Configure VOQ-Level Traffic Shaping, on page 175](#)
- [Bandwidth Remaining, on page 167](#)

Associated Commands

- [priority](#)

Overhead Accounting

Traffic shapers and policers use packet traffic descriptors to ensure adherence to the service level agreement in QoS. However, when traffic flows from one hop to another in a network, headers added or removed at interim hops affect the packet bytes being accounted for by QoS at each hop. When your end-user network measures the packet bytes to ensure they receive the payload as agreed, these additional header bytes cause a discrepancy.

QoS overhead accounting provides the flexibility to operators to decide which header bytes can be excluded by the traffic shaper and policer and which can be included, depending on the end user's requirements and device capabilities, to meet the committed payload in units of bytes.

For example, if the QoS commitment includes the additional header bytes, the overhead accounting feature allows your router to account for this overhead and reduces the traffic policing and shaping rates accordingly. This is also called a **positive accounting overhead**.

If however, the committed rate doesn't include the additional bytes, overhead accounting allows your router to adjust the core stream traffic such that the traffic policing and shaping rates are increased. This is also called a **negative accounting overhead**.

To summarize, QoS overhead accounting enables the router to account for packet overhead when shaping and policing traffic to a specific rate. This accounting ensures that the router runs QoS features on the actual bandwidth that the subscriber traffic consumes.

Any interface that supports QoS policies supports overhead accounting.



Note You can enable user overhead accounting using the optional configuration of **accounting user-defined** *<overhead size in bytes>* while attaching the service policy on the egress interface.

Guidelines and Restrictions

- Overhead accounting for ingress shaping is not supported.

The following restrictions apply for routers that have Cisco NC57 line cards installed and operate in native and compatibility modes.

- More than one compensation value can be programmed, provided you configure egress policy maps on different egress ports.
- You must configure a unique compensation value for a main interface and all sub-interfaces belonging to that main interface. You can't program different compensation values on different sub-interfaces sharing a common main interface.
- You can configure different compensation values on different sub-interfaces if they belong to other main interfaces.
- Compensation value programmed on egress queues (but not on VoQs) will remain active until the last egress policy map (with header compensation) is removed from main or sub-interfaces. This may impact traffic flow on main and sub-interfaces even though no compensation is set for them.

The following restrictions apply for routers that have line cards other than Cisco NC57 line cards.

- You can't program more than one compensation value per NPU or router, even if they're on different egress ports.
- You can configure the same egress compensation for different egress ports.
- NPUs can have different compensation values configured on different line cards in a modular system.
- Compensation value programmed on egress queues (but not on VoQs) will remain active until the last egress policy map (with header compensation) is removed from main or sub-interfaces. This may impact traffic flow on main and sub-interfaces even though no compensation is set for them.

Configuring for Overhead Accounting

To configure overhead accounting, you must:

1. Create a policy map and configure QoS actions for that map.
2. Configure overhead accounting and attach the map to an egress interface.

```
/* create QoS policy */
Router#configure terminal
Router(config)#policy-map policer
Router(config-pmap)#class class-default
Router(config-pmap-c)#police rate percent 10
Router(config-pmap-c-police)#commit

/* configure account overhead value while attaching the QoS policy to an egress interface */
Router(config)#int hundredGigE 0/0/0/2
Router(config-if)#service-policy output policer account user-defined 12
Router(config-if)#commit
Router(config-if)#root
Router(config)#end
```

Running Configuration

```
Router#sh run int hundredGigE 0/0/0/2
interface HundredGigE0/0/0/2
service-policy output policer account user-defined 12
!
```

The following example shows how to **configure a negative overhead accounting value**:

```
Router#conf
Router(config)#int hundredGigE 0/0/0/2
Router(config-if)#service-policy output policer account user-defined -12
Router(config-if)#commit
```

To **modify an overhead accounting value**, you must:

1. Remove the existing QoS policy and re-add it.
2. Configure the new overhead accounting value.

```
Router#conf
Router(config)#int hundredGigE 0/0/0/2
Router(config-if)#no service-policy input policer
Router(config-if)#service-policy output policer account user-defined -20
Router(config-if)#commit
Router#sh run int hundredGigE 0/0/0/2
interface HundredGigE0/0/0/2
service-policy output policer account user-defined -20
!
```

Positive Accounting Use Case

If QoS commitment includes Preamble, Frame Delimiter & Interframe Gap and has the following configuration:

```
service-policy output <foo> account user-defined +20
```

For QoS purposes, your router treats this packet as a packet of size = Actual Packet size + 20. Hence, the effective policing and shaping is *reduced* to match the downstream interface.

Negative Accounting Use Case

If QoS commitment to your router does not include VLAN header information, and has the following configuration:

```
service-policy output <foo> account user-defined -4
```

For QoS purposes, your router treats this packet as a packet of size = Actual Packet size – 4. Hence, the effective policing and shaping is *increased* to match the downstream interface.

Associated Commands

service-policy (overhead accounting)

Traffic Shaping

Traffic shaping allows you to control the traffic flow exiting an interface to match its transmission to the speed of the remote target interface and ensure that the traffic conforms to policies contracted for it. Traffic adhering to a particular profile can be shaped to meet downstream requirements, hence eliminating bottlenecks in topologies with data-rate mismatches.



Note If you apply a policy map that has configured traffic policing and traffic shaping on the basis of a percentage of bandwidth available on the interface and you change the speed of the interface, you must delete that policy map and reattach it to the interface. Else, QoS programming for the earlier speed remains in effect and does not change with change in the port speed.

You can configure traffic shaping at the VOQ level (see [Ingress Traffic Management Model, on page 165](#) Ingress Traffic Management Model to know how the VOQ model works), meaning you can apply shaping policies individually to each VOQ or output port. You can thus achieve fine-grained control over traffic shaping, enabling differentiated treatment of various types of traffic or destinations.

Configure VOQ-Level Traffic Shaping

The traffic shaping performed on outgoing interfaces is done at the Layer 1 level and includes the Layer 1 header in the rate calculation.

Guidelines

- You can configure **shape average** command along with **priority** command.
- From Cisco IOS XR Release 6.6.25 onwards, a shaper on a bundle interface also allows absolute rates apart from the already supported units of percentage, per-thousand and per-million.
From Cisco IOS XR Release 7.4.1 onwards, this is also supported on routers that have Cisco NC57 line cards installed and operate in native and compatibility modes.

Configuration Example

You have to accomplish the following to complete the traffic shaping configuration:

1. Creating or modifying a policy-map that can be attached to one or more interfaces
2. Specifying the traffic class whose policy has to be created or changed
3. Shaping the traffic to a specific bit rate and set peak burst size
4. Attaching the policy-map to an output interface

```
Router# configure
Router(config)#class-map c5
Router(config-cmap)#match traffic-class 5
Router(config-cmap)#commit

Router(config)# policy-map egress_policy1
Router(config-pmap)# class c5
Router(config-pmap-c)# shape average percent 50 1000
Router(config-pmap-c)# exit
Router(config-pmap)# exit
Router(config)# interface HundredGigE 0/1/0/0
Router(config-if)# service-policy output egress_policy1
Router(config-if)# commit
```

Running Configuration

```
class-map c5
  match traffic-class 5
  commit

policy-map egress_policy1
  class c5
    shape average percent 50 1000
```

```

!
class class-default
!
end-policy-map
!

interface HundredGigE0/6/0/18
 service-policy output egress_policy1
!

```

Verification

```
Router# show qos interface tenGigE 0/0/0/0 output
```

```

Wed Jul 10 14:18:37.783 UTC
NOTE:- Configured values are displayed within parentheses
Interface TenGigE0/0/0/0 ifh 0x120 -- output policy
NPU Id:                                0
Total number of classes:                1
Interface Bandwidth:                    10000000 kbps
Policy Name:                            test
VOQ Base:                                1024
Accounting Type:                        Layer1 (Include Layer 1 encapsulation and above)
-----
Level1 Class                            = class-default
Egressq Queue ID                        = 1024 (Default LP queue)
Queue Max. BW.                          = 5031499 kbps (50 %)
Queue Min. BW.                          = 0 kbps (default)
Inverse Weight / Weight                  = 1 / (BWR not configured)
Guaranteed service rate                  = 5000000 kbps
Peak burst                               = 2240 bytes (1000 bytes)
TailDrop Threshold                       = 6258688 bytes / 10 ms (default)

```

Related Topics

- [Congestion Management Overview, on page 163](#)

Associated Commands

- [shape average](#)

Port Shaping

Port shaping, or port-based traffic shaping, is a technique used in QoS to control and manage network traffic on specific ports. Port shaping allows you to prioritize or limit the bandwidth on specific ports to ensure that critical applications receive sufficient network resources while non-critical traffic is restricted.

By implementing port shaping, you can define rules and policies to control the bandwidth allocated to specific ports.

Port shaping can help prevent network congestion, optimize network performance, and ensure that bandwidth is allocated efficiently to meet the requirements of different applications or services.

Key Differences Between VOQ-Level and Port-Level Shapers

Table 40: Differences Between VOQ-level and Port-level Shapers

Parameter	VOQ-Level Shaper	Port-Level Shaper
Granularity	Operates at the individual output queue level within a network device. It shapes the traffic on a per-queue basis.	Operates at a network device's interface or port level. It shapes the overall traffic on the port, affecting all the traffic passing through that interface.
Operational	Helps manage bandwidth usage for different traffic flows or classes within the device.	Helps manage the aggregate bandwidth usage for the entire port.
Traffic control	Allows for granular control and shaping of traffic at the queue level.	Provides high-level control over the shaping of traffic, as it shapes all the traffic passing through the port without differentiating between individual flows or classes.
When to use	Useful when you need to manage and shape traffic per-flow or per-class basis, providing more precise control.	Helpful when you want to manage the overall bandwidth utilization of a port without the need for fine-grained control or differentiation between specific traffic types.

Burst Size for VOQ-Level Shaper

Virtual Output Queue (VOQ)-level shaper burst refers to the burst size or capacity set in a VOQ-level shaper.

A VOQ level shaper within a switch or router regulates the rate at which packets are transmitted from the VOQs to the output ports in a given time interval.

The burst size or capacity in a VOQ-level shaper determines the maximum number of packets or bytes transmitted from a VOQ during a traffic burst. It defines the burst size allowed before the shaper starts limiting the traffic to conform to the specified rate.

The burst setting is thus essential in VOQ-level shaping as it affects the burstiness or the ability to handle traffic bursts. A larger burst size allows larger traffic bursts to be transmitted before the shaping mechanism restricts the flow to conform to the desired rate. Similarly, a smaller burst size limits the burstiness of the traffic and ensures a smoother and more controlled transmission.

Configure Burst Size for VOQ-Level Shaper

See [Configure VOQ-Level Traffic Shaping, on page 175](#) for details.

Burst Size for Port-Level Shaper

Table 41: Feature History Table

Feature Name	Release Information	Feature Description
Burst Size for Port-Level Shaper	Release 7.11.1	<p>Introduced in this release on: NCS 5500 fixed port routers; NCS 5700 fixed port routers; NCS 5500 modular routers (NCS 5500 line cards; NCS 5700 line cards [Mode: Compatibility; Native])</p> <p>You can now achieve a predictable and accurate burst size at the link level by configuring port-level shaper burst size, thus ensuring better adherence to traffic SLAs. Also, with the port-level shaper burst size configured in the egress policy maps, the predictability in peak burst ensures that you can configure any next-hop low-capacity device to handle these bursts.</p> <p>Previously, you could configure burst sizes, which impacted traffic flow only at the Virtual Output Queue (VOQ) level but didn't control packet transmission at the link level.</p>

In relation to a port-level shaper, the burst size refers to the maximum amount of data that can be sent through the port within a short period, exceeding the configured shaping rate. When traffic is shaped at the port level, the shaping algorithm smooths the traffic flow by limiting the average rate at which data is transmitted or received. However, there are scenarios where bursts of traffic may occur, such as during periods of high network activity or when multiple packets arrive simultaneously. In such scenarios, the burst size parameter represents the maximum burst of traffic that the port-level shaper allows before it starts to drop or delay packets.

This value influences the packet transmission and peak burst to the wire, irrespective of the shaper bursts configured on different VOQs. Thus, by providing tighter control of packet flow to the wire and next-hop devices, this functionality helps you achieve accurate and predictable peak bursts.

For example, if you configure the burst size to 100 KB, the shaper allows a burst of up to 100 KB of data to be transmitted within a short period, even if it exceeds the configured shaping rate. If the burst size exceeds 100 KB, the shaper takes action to enforce the shaping rate, such as dropping or delaying packets until the traffic falls within the specified limits. As a corollary, the expected port shaping rate may not be achieved if you configure a very low burst value.

The burst size is programmed on the egress port with:

- a default value of 32 KB for all routers
- a default value of 16 KB for NCS 5700 fixed port routers and NCS 5700 line cards [Mode: Compatibility; Native]

Burst Size for Port-Level Shaper: Why

Because...

Previously, you could configure burst size only for VOQ-level shaping, where the shaper bandwidth and burst sizes are programmed on the Fair Queue Elements (FQEs) in your router hardware. (FQE is a mechanism that allocates bandwidth fairly among different traffic flows or queues, and the FQEs are specific to ingress queues where egress policy maps are applied.)

and..

The VOQ-level shaper burst impacts credit flow for a particular VOQ. Configuring VOQ-level burst is a best-effort technique but may not translate to the intended peak burst at the link level.

Hence...

The burst size for the port level is port or egress queue-specific, and when you configure it, you have control over packet transmission at the link level, which means you achieve an accurate peak burst in the wire. This predictability in the burst ensures that low-end devices can absorb the burst according to their capability, and there's no unexpected drop in traffic.

Burst Size for Port-Level Shaper: Guidelines and Limitations

- This functionality is supported on all NCS 5700 Series Routers and NCS 5500 Series Routers.
- You must configure the port burst along with the port shaper to activate this functionality.
- The burst size is configured on the port and egress queue level.
- The default burst values are:
 - 32 KB for all routers.
 - 16 KB for NCS 5700 fixed port routers and NCS 5700 line cards [Mode: Compatibility; Native]
- **For Hierarchical QoS (H-QoS) and egress traffic management (ETM) models:**
 - Port shaper and burst on a particular physical interface are programmed when an egress policy map with only a **class-default** configuration and a configured shaper value is applied on that interface.
 - The shaper rate on the default class is calculated as the port shaper and the burst as the port burst.
 - For NCS 5700 line cards [Mode: Compatibility; Native] and NCS 5700 fixed port routers:
 - the port shaper is not supported if no port burst is configured. This limitation does not apply to other platforms.
 - Three-level H-QoS isn't supported. This means that you can't apply two-level egress H-QoS policies on the sub-interfaces and a port shaper policy on the main interface to achieve an aggregated port level SLA in a 1+2 H-QoS or three-level H-QoS model. See [Overview of Hierarchical Modular QoS, on page 219](#) for details about H-QoS.

- **For non-H-QoS and non-ETM models:**

- Port level burst on a particular interface is programmed when you configure it along with port shaper.
- You must attach a two-level egress QoS policy map to the main interface. Here, the parent shaper is taken as the port shaper.
- The shaper rate on the parent policy configured for the default class is considered as port shaper and the burst as port burst.
- For NCS 5700 line cards [Mode: Compatibility; Native] and NCS 5700 fixed port routers, the minimum port shaper is 3 Gbps by default if no port burst is configured. For other platforms, the default minimum port shaper value is 1 Gbps. If the port burst is configured, there is no limitation on the minimum port shaper value.
- The port burst value configured on the egress interface doesn't restrict the burst sizes on the VOQs or child classes.
- The parent shaper burst size doesn't restrict the child shaper burst size. Unlike the child shaper bandwidth, a child shaper burst can be greater than the parent shaper burst.
- The actual burst size programmed on the ASIC could vary from the configured value due to a hardware approximation.

Configure Burst Size for Port-Level Shaper

Scenario 1: For Cisco NCS 5700 Series Routers, NCS 5700 line cards, and NCS 5500 Series Routers, in non-H-QoS and non-ETM mode: Assign Port Burst Value

In this scenario, you specifically assign a burst value (say, 2000 bytes) along with the shaper rate (say, 2 Gbps) on a parent policy configured to the default class. These parent shaper and burst values are taken as the port shaper and burst.

1. Create a two-level egress QoS policy map by configuring the parent policy with name, for example, **port-shaper-non-hqos**.
2. Configure the **port-shaper-non-hqos** policy for the default class. There should be no other class other than the default class in the policy map.
3. To the parent policy, apply a child policy named, for example, **egress-child**, using the **service-policy** command.
4. Configure a burst value of 2000 bytes and shaper rate of 2 Gbps for the parent (**port-shaper-non-hqos**) policy.
5. Using the **class** command, specify a traffic class (say **traffic-class-1**) for the child policy (**egress-child**).
6. Using the **shape average** command, configure the shape average for **traffic-class-1** to say, 25%.
7. Attach the parent policy map to the output interface to be used as the service policy for that interface.

This configuration applies the parent shaper and burst values that are taken as the port-level shaper and burst values.

```
Router(config)# policy-map port-shaper-non-hqos
Router(config-pmap)# class class-default
Router(config-pmap-c)# service-policy egress-child
```

```

Router(config-pmap-c) # shape average 2 gbps 2000 bytes
Router(config-pmap-c) # exit
Router(config) # policy-map egress-child
Router(config-pmap) # class traffic-class-1
Router(config-pmap-c) # shape average percent 25
Router(config-pmap-c) # exit
Router(config) # interface tenGigE 0/0/0/0
Router(config-if) # service-policy output port-shaper-non-hqos
Router(config-if) # commit

```

Running Configuration

```

policy-map port-shaper-non-hqos
  class class-default
    service-policy egress-child
    shape average 2 gbps 2000 bytes
  !
!
policy-map egress-child
  class traffic-class-1
    shape average percent 25
  !
!

interface tenGigE 0/0/0/0
  service-policy output port-shaper-non-hqos
!

```

Verification

Run the **show qos interface** command to confirm the Peak burst value (2000 bytes) you configured for the default class.

```

Router#show qos interface tenGigE 0/0/0/0 output
NOTE:- Configured values are displayed within parentheses
Interface TenGigE0/0/0/0 ifh 0x120 -- output policy
NPU Id:                                0
Total number of classes:                3
Interface Bandwidth:                    10000000 kbps
Policy Name:                            port-shaper-non-hqos
SPI Id:                                 0x0
VOQ Base:                                1024
PFC enabled:                             0
Accounting Type:                        Layer1 (Include Layer 1 encapsulation and above)
-----
Level1 Class                            = class-default
Queue Max. BW.                          = 2020026 kbps (2 gbits/sec)
Queue Min. BW.                          = 2020026 kbps (default)
Inverse Weight / Weight                  = 1 / (BWR not configured)
Peak burst                             = 2000 bytes (2000 bytes)

Level2 Class                             = traffic-class-1
Egressq Queue ID                        = 1025 (LP queue)
Queue Max. BW.                          = 505417 kbps (25 %)
Queue Min. BW.                          = 0 kbps (default)
Inverse Weight / Weight                  = 1 / (BWR not configured)
Guaranteed service rate                  = 500000 kbps
Peak burst                               = 33600 bytes (default)
TailDrop Threshold                       = 626688 bytes / 10 ms (default)
WRED not configured for this class

Level2 Class                             = class-default
Egressq Queue ID                        = 1024 (Default LP queue)
Queue Max. BW.                          = no max (default)

```

```

Queue Min. BW.                = 0 kbps (default)
Inverse Weight / Weight       = 1 / (BWR not configured)
Guaranteed service rate       = 1000000 kbps
Peak burst                     = 33600 bytes (default)
TailDrop Threshold            = 1253376 bytes / 10 ms (default)
WRED not configured for this class

```

Scenario 2: For Cisco NCS 5700 Series Routers, NCS 5700 line cards, and NCS 5500 Series Routers, in non-H-QoS mode: Don't Assign Port Burst Value

In this scenario, you assign only the port shaper value (say, 2 Gbps) to the default class. In such cases, the burst size for port level shaper isn't activated, and the parent class has no port burst value.

1. Create a parent policy map named, for example, **port-shaper-non-hqos**.
2. Configure the **port-shaper-non-hqos** policy for the default class.
3. Apply a child policy-map named, for example, **egress-child** to the default class.
4. Shape the traffic in the default class to an average rate of 2 Gbps, limiting the egress traffic to a specific bandwidth.
5. Attach the parent policy map to the output interface to be used as the service policy for that interface.

```

Router(config)#policy-map port-shaper-non-hqos
Router(config-pmap)#class class-default
Router(config-pmap-c)#service-policy egress-child
Router(config-pmap-c)#shape average 2 gbps
Router(config-pmap-c)#exit
Router(config-pmap)#exit
Router(config)# interface tenGigE 0/0/0/0
Router(config-if)# service-policy output port-shaper-non-hqos
Router(config-if)#commit

```

Running Configuration

```

policy-map port-shaper-non-hqos
  class class-default
    service-policy egress-child
    shape average 2 gbps
  !
!
interface tenGigE 0/0/0/0
  service-policy output port-shaper-non-hqos
!

```

Verification

When you run the **show qos interface** command, you see no port burst value assigned to the parent class.

```

Router#show qos interface tenGigE 0/0/0/0 output
Sun Sep 10 20:17:16.053 UTC
NOTE:- Configured values are displayed within parentheses
Interface TenGigE0/0/0/0 ifh 0xa0 -- output policy
NPU Id:                0
Total number of classes: 3
Interface Bandwidth:    10000000 kbps
Policy Name:            port-shaper-non-hqos
SPI Id:                 0x0
VOQ Base:               1024
PFC enabled:            0

```

```

Accounting Type:                Layer1 (Include Layer 1 encapsulation and above)
-----
Level1 Class                    = class-default
Queue Max. BW.                 = 2100096 kbps (2 gbits/sec)
Queue Min. BW.                 = 2100096 kbps (default)
Inverse Weight / Weight        = 1 / (BWR not configured)

Level2 Class                    = traffic-class-1
Egressq Queue ID               = 1025 (LP queue)
Queue Max. BW.                 = 505861 kbps (25 %)
Queue Min. BW.                 = 0 kbps (default)
Inverse Weight / Weight        = 1 / (BWR not configured)
Guaranteed service rate        = 500000 kbps
Peak burst                     = 33600 bytes (default)
TailDrop Threshold             = 626688 bytes / 10 ms (default)
WRED not configured for this class

Level2 Class                    = class-default
Egressq Queue ID               = 1024 (Default LP queue)
Queue Max. BW.                 = 1011732 kbps (50 %)
Queue Min. BW.                 = 0 kbps (default)
Inverse Weight / Weight        = 1 / (BWR not configured)
Guaranteed service rate        = 1000000 kbps
Peak burst                     = 33600 bytes (default)
TailDrop Threshold             = 1253376 bytes / 10 ms (default)
WRED not configured for this class

```

Scenario 3: For NCS 5700 Series Routers and NCS 5700 line cards, in H-QoS and ETM-enabled mode: Assign Port Burst Value

In this scenario, you specifically assign a burst value (say, 2000 bytes) along with the shaper rate (say, 2 Gbps) on the default class.) See [Burst Size for Port-Level Shaper: Guidelines and Limitations, on page 179](#) for limitations that apply to this scenario.

1. Create a policy map named, for example, **port-shaper-hqos**.
2. Configure the **port-shaper-hqos** policy for the default class. The **class-default** class matches all traffic that does not match any other specific class. There should be no other class other than the default class in the policy map.
3. Configure the traffic shaping rate and the burst value for the **class-default** class.
4. Apply the policy-map named **port-shaper-hqos** as the output service policy for the interface.

```

Router (config)# policy-map port-shaper-hqos
Router (config-pmap)# class class-default
Router (config-pmap-c)# shape average 2 gbps 2000 bytes
Router (config-pmap-c)#exit
Router (config-pmap)#exit
Router (config)# interface tenGigE 0/0/0/0
Router (config-if)# service-policy output port-shaper-hqos
Router (config-if)#commit

```

Running Configuration

```

policy-map port-shaper-hqos
  class class-default
    shape average 2 gbps 2000 bytes
  !
!
interface tenGigE 0/0/0/0

```

```
service-policy output port-shaper-hqos
!
```

Verification

Run the `show qos interface` to confirm the peak burst value (2000 bytes) you configured for the default class. Because there's no three-level H-QoS shaping support on NCS 5700 line cards [Mode: Compatibility; Native] and NCS 5700 fixed port routers, the output displays only the default class details (and not other child levels) for which you configured the shaper and burst values.

```
Router#show qos interface tenGigE 0/0/0/0 output
NOTE:- Configured values are displayed within parentheses
Interface TenGigE0/0/0/0 ifh 0xa0 -- output policy
NPU Id: 0
Total number of classes: 1
Interface Bandwidth: 10000000 kbps
Policy Name: port-shaper-hqos
SPI Id: 0x0
VOQ Base: 1024
PFC enabled: 0
Accounting Type: Layer1 (Include Layer 1 encapsulation and above)
-----
Level1 Class = class-default
Egressq Queue ID = 1024 (Default LP queue)
Queue Max. BW. = 2024355 kbps (2 gbits/sec)
Queue Min. BW. = 0 kbps (default)
Inverse Weight / Weight = 60 / (BWR not configured)
Guaranteed service rate = 2000000 kbps
Peak burst = 2000 bytes (2000 bytes)
TailDrop Threshold = 2506752 bytes / 10 ms (default)
WRED not configured for this class
```

4K Pseudowire on Bundle with QoS Enhancement

Table 42: Feature History Table

Feature Name	Release Information	Feature Description
4K Pseudowire on Bundle with QoS Enhancement	Release 7.3.1	<p>With this feature you can configure a desired traffic policy, to which your network complies, by using the bandwidth management technique of two-level traffic shaping. You can also increase the Link Aggregation Group (LAG) sub-interface scale or pseudowires up to 4K.</p> <p>This increased scale value enables you to increase the number of devices connected to your router, resulting in benefits such as increased bandwidth and cost-effective operations.</p>

Your router supports two modes of egress traffic shaping:

- The **default non-Hierarchical QoS (H-QoS) mode**, where the egress traffic shaping is configured only on main interfaces and no hierarchical policies are supported. In other words, egress traffic shaping on subinterfaces isn't supported in this mode.
- The **H-QoS mode**, where egress traffic shaping is also supported on subinterfaces. This mode also supports hierarchical policies on the main and subinterfaces.

Prior to Cisco IOS XR Release 7.3.1, the H-QoS mode restricted the scale of subinterfaces you could configure. For example, the maximum Link Aggregation Group (LAG) subinterface scale or pseudowires is 1K in the H-QoS mode.

The enhancement described in this section, available from Cisco IOS XR Release 7.3.1 is applicable for the default non-H-QoS mode for egress QoS. It involves configuring two-level traffic shaper policy on the main interface, while enabling you to increase the LAG subinterface scale or pseudowires to as much as 4K. What this means is that you can also scale up the number of access devices you want to connect through LAG to your router, thus enabling:

- Increased reliability and availability
- Better use of physical resources
- Increased bandwidth
- Cost-effective operations

Restrictions and Guidelines

The following restrictions and guidelines apply while configuring two-level traffic shaper policy on the main interface in (default) non-H-QoS mode:

- The hierarchical egress policy support is only for main interfaces.
- Subinterface behavior remains the same in non-H-QoS mode. No egress QoS support is available for subinterfaces.
- This enhancement is applicable only for egress QoS, and there are no changes in ingress QoS behavior.
- There's no change to the current non-H-QoS flat policy behavior.
- The minimum shaper rate varies between different ASICs.

Configure Two-Level Shaper Policy on Main Interface

To configure two-level shaper policy on main interface, you must:

1. Enter global configuration mode and create a two-level policy map.
2. Attach this policy map to the main interface.

```
/* Enter the global configuration mode and create the two-level policy map */
Router#configure
Router(config)# policy-map two-level-pm
Router(config-pmap)#class class-default
Router(config-pmap-c)#shape average percent 20
Router(config-pmap-c)#service-policy child
Router(config-pmap-c)#root
```

```

Router(config)#policy-map child
Router(config-pmap)#class class-default
Router (config-pmap-c)#shape average percent 5
Router(config-pmap-c)#commit

/* Apply policy-map under interface */
Router(config)#interface hundredGigE 0/0/0/3
Router(config-intf)#service-policy output policy
Router(config-intf)#commit

```

Running Configuration

```

Router#show running-config policy-map two-level-pm
policy-map two-level-pm
  class class-default
    service-policy child
    shape average percent 20
  !
end-policy-map
!

Router#show running-config interface hundredGigE 0/0/0/3
interface HundredGigE0/0/0/3
service-policy output two-level-pm
!

```

Verification

Verify that the maximum bandwidth (shaping rate) for the parent policy (Level 1) is greater than the rate for the child policy at Level 2.

```

Router#show qos interface hundredGigE 0/0/0/3 output
NOTE:- Configured values are displayed within parentheses
Interface HundredGigE0/0/0/3 ifh 0x68 -- output policy
NPU Id: 0
Total number of classes: 2
Interface Bandwidth: 100000000 kbps
Policy Name: two-level-pm
SPI Id: 0x0
VOQ Base: 1048
Accounting Type: Layer1 (Include Layer 1 encapsulation and above)
-----
Level1 Class = class-default
Queue Max. BW. = 20004211 kbps (20 %)
Queue Min. BW. = 20000305 kbps (default)
Inverse Weight / Weight = 1 / (BWR not configured)

Level2 Class = class-default
Egressq Queue ID = 1048 (Default LP queue)
Queue Max. BW. = 1000000 kbps (5 %)
Queue Min. BW. = 0 kbps (default)
Inverse Weight / Weight = 1 / (BWR not configured)
Guaranteed service rate = 1000000 kbps
Peak burst = 36864 bytes (default)
TailDrop Threshold = 1249792 bytes / 10 ms (default)
WRED not configured for this class

```

Traffic Policing

Traffic policing allows you to control the maximum rate of traffic sent or received on an interface and to partition a network into multiple priority levels or class of service (CoS). Traffic policing manages the maximum rate of traffic through a token bucket algorithm. The token bucket algorithm uses user-configured values to determine the maximum rate of traffic allowed on an interface at a given moment in time. The token bucket algorithm is affected by all traffic entering or leaving the interface (depending on where the traffic policy with traffic policing is configured) and is useful in managing network bandwidth in cases where several large packets are sent in the same traffic stream. By default, the configured bandwidth value takes into account the Layer 2 encapsulation that is applied to traffic leaving the interface.

Traffic policing also provides a certain amount of bandwidth management by allowing you to set the burst size (Bc) for the committed information rate (CIR). See, [Committed Bursts and Excess Bursts, on page 188](#).

The router supports the following traffic policing mode(s):

- Single-Rate Two-Color (SR2C) in color-blind mode. See [Single-Rate Policer, on page 188](#).
- Single-Rate Three-Color (SR3C) in color-blind mode.
- Two-Rate Three-Color (2R3C) in color-blind mode. See [Two-Rate Policer, on page 192](#).



Note In NC57-18DD-SE, QoS enhanced stats is enabled by default.

Restrictions

- If you apply a policy map that has configured traffic policing and traffic shaping on the basis of a percentage of bandwidth available on the interface and you change the speed of the interface, you must delete that policy map and reattach it to the interface. Else, QoS programming for the earlier speed remains in effect and does not change with change in the port speed.
- Traffic policing is supported only in ingress direction, and only color-blind mode is supported.
- The policing rate accuracy may vary up to +/-2% from the configured policer value.
- Ensure that you don't configure a policer and match criteria for **discard-class** in the same class. Even though the configuration is allowed, the policer doesn't work and allows all traffic without dropping packets.
- Policer marking is not supported.
- Policers are configured in the interface at the core level and "show qos int <>" value is displayed at the NPU level.

For policers configured in a bundle interface where bundle members are from the same NPU but different cores (NPU cores), each member sends the traffic up to the core level policer configuration, but "show qos int <>" displays the NPU level policer output.

- Example:

For bundle interface with two 10GE members (same NPU, but one interface from core0, one interface from core1) 2R3C policer applied on bundle interface (1G confirm rate, 1G exceed rate – total 2G policer rate) will be shown on the “show qos int <>” output):

Interface in core0 – 500 Mbps confirm rate, 500 Mbps exceed rate

Interface in core1 – 500 Mbps confirm rate, 500 Mbps exceed rate

For traffic in one out of two interfaces, the policed rate will be 1Gbps. For traffic on two interfaces, policed rate will be 2Gbps.

Committed Bursts and Excess Bursts

Unlike a traffic shaper, a traffic policer does not buffer excess packets and transmit them later. Instead, the policer executes a “send or do not send” policy without buffering. Policing uses normal or committed burst (bc) values and excess burst values (be) to ensure that the router reaches the configured committed information rate (CIR). Policing decides if a packet conforms or exceeds the CIR based on the burst values you configure. Burst parameters are based on a generic buffering rule for routers, which recommends that you configure buffering to be equal to the round-trip time bit-rate to accommodate the outstanding TCP windows of all connections in times of congestion. During periods of congestion, proper configuration of the excess burst parameter enables the policer to drop packets less aggressively.

For more details, see [Committed Bursts, on page 207](#) and [Excess Bursts, on page 207](#).

Single-Rate Policer

Single-Rate Two-Color Policer

A single-rate two-color (SR2C) policer provides one token bucket with two actions for each packet: a conform action and an exceed action.

Figure 6: Workflow of Single-Rate Two-Color Policer

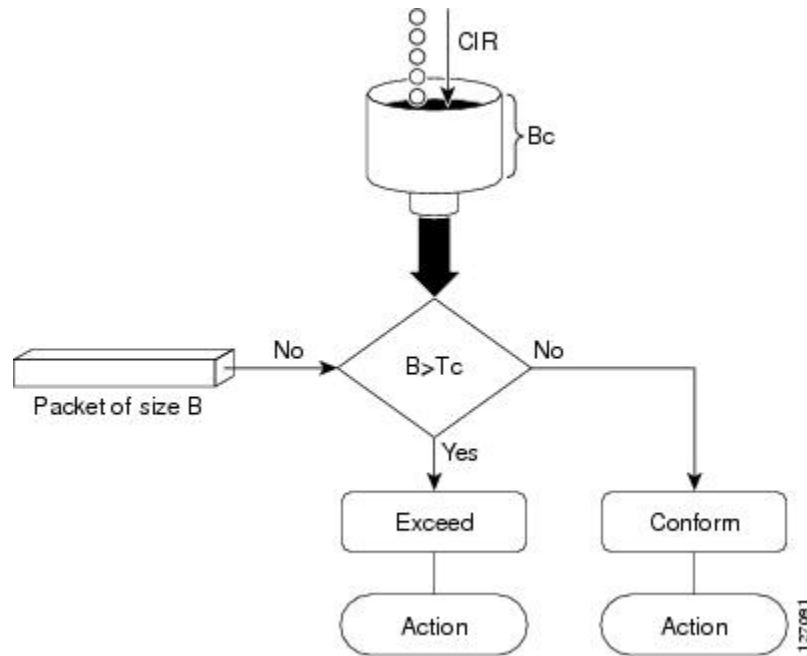

Based on the committed information rate (CIR) value, the token bucket is updated at every refresh time interval. The T_c token bucket can contain up to the B_c value, which can be a certain number of bytes or a period of time. If a packet of size B is greater than the T_c token bucket, then the packet exceeds the CIR value and a default action is performed. If a packet of size B is less than the T_c token bucket, then the packet conforms and a different default action is performed.

Single-Rate Three-Color Policer

A single-rate three-color (SR3C) policer provides one token bucket with three actions for each packet: a conform action, an exceed action and a violate action. The packet is marked based on the CIR value and the two associated burst size - committed burst size (CBS) and excess burst size (EBS). If a packet does not exceed the CBS, it is marked as conformed packet. The packet is marked as exceeded if it exceeds CBS, but not the EBS. If it exceeds the EBS as well, it is marked as violate packet.

Configure Traffic Policing (Single-Rate Two-Color)

Traffic policing is often configured on interfaces at the edge of a network to limit the rate of traffic entering or leaving the network. The default conform action for single-rate two color policer is to transmit the packet and the default exceed action is to drop the packet. Users cannot modify these default actions.

Configuration Example

You have to accomplish the following to complete the traffic policing configuration:

1. Creating or modifying a policy-map that can be attached to one or more interfaces
2. Specifying the traffic class whose policy has to be created or changed
3. (Optional) Specifying the marking action
4. Specifying the policy rate for the traffic

5. Attaching the policy-map to an input interface

```

Router# configure
Router(config)# policy-map test-police-1
Router(config-pmap)# class ipv6-6
Router(config-pmap-c)# set dscp cs2 (optional)
Router(config-pmap-c)# set qos-group 7 (optional)
Router(config-pmap-c)# police rate percent 20 burst 10000 bytes
Router(config-pmap-c-police)# exit
Router(config-pmap-c)# exit
Router(config-pmap)# exit
Router(config)# interface HundredGigE 0/6/0/18
Router(config-if)# service-policy input test-police-1
Router(config-if)# commit

```

Running Configuration

```

class-map match-any ipv6-6
  match precedence 3
end-class-map
!

policy-map test-police-1
  class ipv6-6
    set dscp cs2
    set qos-group 7
    police rate percent 20 burst 10000 bytes
  !
  !
  class class-default
  !
end-policy-map
!

interface HundredGigE0/6/0/18
  service-policy input test-police-1
  service-policy output test-priority-1
!

```

Verification

```
Router# show qos interface hundredGigE 0/6/0/18 input
```

```

NOTE:- Configured values are displayed within parentheses
Interface HundredGigE0/6/0/18 ifh 0x3000220 -- input policy
NPU Id: 3
Total number of classes: 2
Interface Bandwidth: 100000000 kbps
Accounting Type: Layer1 (Include Layer 1 encapsulation and above)
-----
Level1 Class = ipv6-6
New dscp = 16
New qos group = 7

Policer Bucket ID = 0x102a0
Policer Stats Handle = 0x8a8090c0
Policer committed rate = 19980000 kbps (20 %)

```

```

Policer conform burst           = 9856 bytes (10000 bytes)

Levell Class                    = class-default

Default Policer Bucket ID      = 0x102a1
Default Policer Stats Handle   = 0x8a808e78
Policer not configured for this class

```

Related Topics

- [Traffic Policing, on page 187](#)

Associated Commands

- [police rate](#)

Configure Traffic Policing (Single-Rate Three-Color)

The default conform action and exceed actions for single-rate three-color policer are to transmit the packet and the default violate action is to drop the packet. User cannot modify these default actions.

Configuration Example

You have to accomplish the following to complete the traffic policing configuration:

1. Creating or modifying a policy-map that can be attached to one or more interfaces
2. Specifying the traffic class whose policy has to be created or changed
3. (Optional) Specifying the marking action
4. Configuring the policy rate for the traffic along with the peak-burst values
5. Attaching the policy-map to an input interface

```

Router# configure
Router(config)# policy-map test-police-1R3C
Router(config-pmap)# class ipv4-5
Router(config-pmap-c)# set qos-group 2 (optional)
Router(config-pmap-c)# police rate percent 20 burst 100000 bytes peak-burst 190000 bytes
Router(config-pmap-c-police)# exit
Router(config-pmap-c)# exit
Router(config-pmap)# exit
Router(config)# interface HundredGigE 0/6/0/18
Router(config-if)# service-policy input test-police-1R3C
Router(config-if)# commit

```

Running Configuration

```

class-map match-any ipv4-5
  match precedence 3
end-class-map
!

policy-map test-police-1R3C

```

```

class ipv4-5
  set qos-group 7
  police rate percent 20 burst 100000 bytes peak-burst 190000 bytes
  !
!
class class-default
!
end-policy-map
!

interface HundredGigE0/6/0/18
  service-policy input test-police-1R3C
  service-policy output test-priority-1
!

```

Verification

```
Router# show qos interface hundredGigE 0/6/0/18 input
```

```

NOTE:- Configured values are displayed within parentheses
Interface HundredGigE0/6/0/18 ifh 0x3000220 -- input policy
NPU Id:                               3
Total number of classes:               2
Interface Bandwidth:                   100000000 kbps
Accounting Type:                       Layer1 (Include Layer 1 encapsulation and above)
-----
Level1 Class                           =   ipv4-5
New qos group                           =     2

Policer Bucket ID                      =   0x102a1
Policer Stats Handle                   =   0x8a8090c0
Policer committed rate                 =   19980000 kbps (20 %)
Policer conform burst                  =   99584 bytes (100000 bytes)
Policer exceed burst                   =   188672 bytes (190000 bytes)

Level1 Class                            =   class-default

Default Policer Bucket ID              =   0x102a1
Default Policer Stats Handle           =   0x8a808e78
Policer not configured for this class

```

Related Topics

- [Traffic Policing, on page 187](#)

Associated Commands

- [police rate](#)

Two-Rate Policer

The two-rate policer manages the maximum rate of traffic by using two token buckets: the committed token bucket and the peak token bucket. The dual-token bucket algorithm uses user-configured values to determine the maximum rate of traffic allowed on a queue at a given moment. In this way, the two-rate policer can meter traffic at two independent rates: the committed information rate (CIR) and the peak information rate (PIR).

The dual-token bucket algorithm provides users with three actions for each packet—a conform action, an exceed action, and an optional violate action. Traffic entering a queue with the two-rate policer configured is placed into one of these categories. The actions are pre-determined for each category. The default conform and exceed actions are to transmit the packet, and the default violate action is to drop the packet.

This figure shows how the two-rate policer marks a packet and assigns a corresponding action to the packet.

Figure 7: Marking Packets and Assigning Actions—Two-Rate Policer

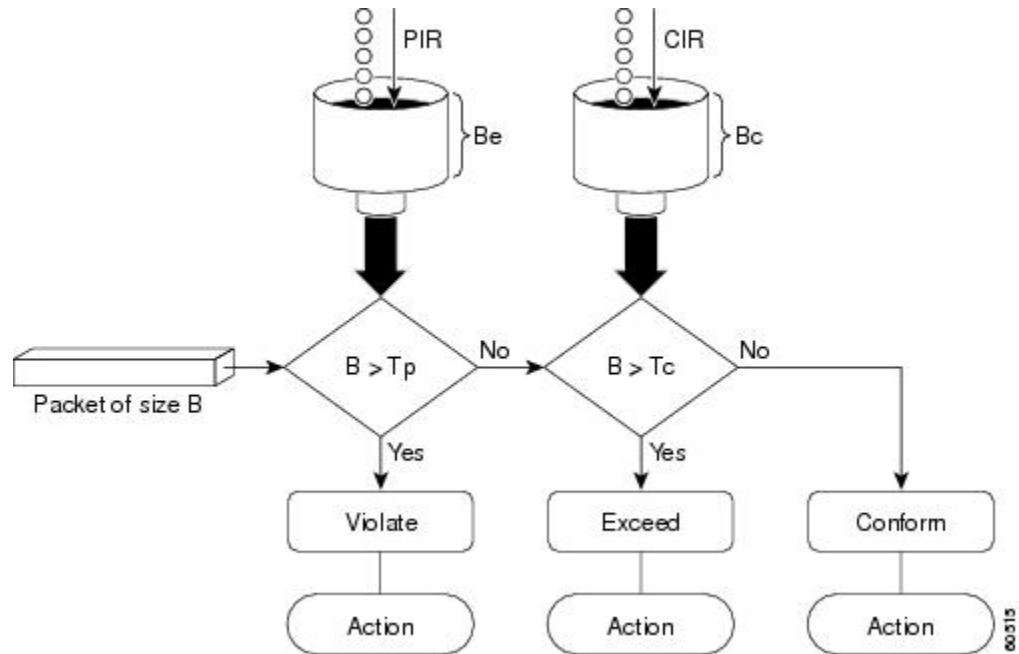

Also, see [Two-Rate Policer Details](#), on page 208.

The router supports Two-Rate Three-Color (2R3C) policer.

Configure Traffic Policing (Two-Rate Three-Color)

The default conform and exceed actions for two-rate three-color (2R3C) policer are to transmit the packet and the default violate action is to drop the packet. Users cannot modify these default actions.

Configuration Example

You have to accomplish the following to complete the two-rate three-color traffic policing configuration:

1. Creating or modifying a policy-map that can be attached to one or more interfaces
2. Specifying the traffic class whose policy has to be created or changed
3. Specifying the packet marking
4. Configuring two rate traffic policing
5. Attaching the policy-map to an input interface

```

Router# configure
Router(config)# policy-map policy1
  
```

```

Router(config-pmap)# class ipv4-7
Router(config-pmap-c)# set qos-group 4
Router(config-pmap-c)# police rate percent 20 burst 100000 bytes peak-rate percent 50
peak-burst 200000 bytes
Router(config-pmap-c-police)# exit
Router(config-pmap-c)# exit
Router(config-pmap)# exit
Router(config)# interface HundredGigE 0/6/0/18
Router(config-if)# service-policy input policy1
Router(config-if)# commit

```

Running Configuration

```

policy-map policy1
  class ipv4-7
    set qos-group 4
    police rate percent 20 burst 100000 bytes peak-rate percent 50 peak-burst 200000 bytes
  !
!

interface HundredGigE 0/6/0/18
  service-policy input policy1
!

```

Verification

```
Router# show policy-map interface HundredGigE 0/6/0/18
```

```

NOTE:- Configured values are displayed within parentheses
Interface HundredGigE0/6/0/18 ifh 0x3000220 -- input policy
NPU Id: 3
Total number of classes: 8
Interface Bandwidth: 100000000 kbps
Accounting Type: Layer1 (Include Layer 1 encapsulation and above)
-----
Level1 Class = ipv4-4
- - -
Level1 Class = ipv4-7
New qos group = 4

Policer Bucket ID = 0x102a3
Policer Stats Handle = 0x8a8089e8
Policer committed rate = 19980000 kbps (20 %)
Policer peak rate = 49860000 kbps (50 %)
Policer conform burst = 99584 bytes (100000 bytes)
Policer exceed burst = 199168 bytes (200000 bytes)

Level1 Class = class-default

Policer Bucket ID = 0x102a7
Policer Stats Handle = 0x8a7c8510
Policer committed rate = 29880000 kbps (30 %)
Policer conform burst = 4194304 bytes (default)

```

Important Notes

- From Cisco IOS XR Release 6.6.25 onwards:
 - a committed information rate of 0 kbps is supported, which is the only exception to the minimum rate of 22 kbps for both commit and excess rates.
 - a policer on a bundle interface also allows absolute rates apart from the already supported units of percent, per-thousand and per-million. From Cisco IOS XR Release 7.4.1 onwards, this is also supported on routers that have Cisco NC57 line cards installed and operate in native and compatibility modes.
- A policer is programmed per NPU core on a bundle interface. So, all members on a bundle interface from the same core share the policer.

Related Topics

- [Two-Rate Policer, on page 192](#)

Associated Commands

- [police rate](#)

Packets-Per-Second-Based Policer

Table 43: Feature History Table

Feature Name	Release Information	Feature Description
Packets-Per-Second-Based Policer	Release 7.4.1	<p>Prior to this functionality, when configuring policers, the only available option for policer rates was bit-rate measured in units of bits per second (bps). With this release, you can configure policer rates in units of packets per second (pps) as well. pps-based policer is critical in fending off malicious attacks—when attackers target your specific resources with a vast amount of traffic that contain higher number of packets, but move at a slower packet rate. Protection from such attacks is possible because pps-based policers ensure that regardless of the packet size and rate, the policer only accepts a fixed number of packets per second.</p> <p>This functionality modifies the police rate command.</p>

- **Policer rates so far**—You used the **police rate** command to configure policers based on two parameters:
 - bit-rates (default unit: bits per second or bps)
 - Burst size (default unit: bytes)
- **packets-per-second (pps)-based policer**—With this additional functionality, you can use the **police rate** command to configure policers in units of packets per second (pps). The pps configuration option is available as **police rate <pps-value> pps**. When you configure the pps option, ensure that you configure burst size in packets. (See **Restrictions and guidelines**.) Thus, the parameters for pps-based policer are:
 - packets per second (pps)
 - burst size (packets)
- **Why pps-based-policer**—Networks face newer types of attacks, and these days malicious operators don't necessarily employ aggressive tactics that involve overwhelming your bandwidth with large amount of traffic to cause distributed denial of service (DDoS). Now, some attackers go the 'softer' route, where they send smaller packet sizes at slower traffic rates. During such malicious network activity, a bandwidth-based policer can still aggregate up to many packets to be processed if the packet size is small. Attackers tend to use this behavior to bypass bandwidth-based policers to exploit vulnerabilities or try to hit performance limitations by increasing the packet rates.

Packets-per-second-based policers ensure that regardless of the packet size and traffic rate, the policer only accepts a fixed number of packets per second.

pps-based-policer support cheat-sheet—Here's a quick look at some key support areas and their details for pps-based policer.

Support	Details
Classification and marking support	Same as that for bps-based-policer
Units	Equivalent kbps values display for QoS programming and statistics.
H-QoS	Support for parent and child policers
Bursts	Support for confirm burst (bc) and exceed burst (be) values in units of packets. The default value is in multiple of 128 bytes equivalent to 10 milliseconds.
Minimum pps value	For better granularity, recommended minimum value is 100 pps.

- **Restriction and guidelines**
 - This functionality is **applicable only for ingress**.
 - When using a pps-based policer, **ensure that you configure the burst-size value in number of packets as well**. This is because a policer burst rate determines whether a specific number of packets out of contract would be subject to the next action (that is, exceed or violate).
 - **Within a QoS policy, configure the parent and child policies policers to either bps or pps**. Else, the configuration displays an error when you try attaching the policy to an interface.

- **For single-level policy maps:** under the same policy map, you can configure one class map with bps-based policer and the other class map with a pps-based policer.
- **For two-level hierarchical policy maps:**
 - The parent and child-level policy maps must use the same unit-based policer. That is, both must have either pps-based or bps-based policers.
 - If you configure the child-level policy map with pps-based policer, ensure that the parent policy-map class default has a pps-based policer.
- **Configure pps-based policer**—To configure pps-based policer, you must:
 1. Configure a class map.
 2. Create a service policy for the map and configure the pps values.
 3. Attach the service policy to an interface.

```

/*Configure a class map*/

Router(config)#class-map prec1
Router(config-cmap)#match precedence 1
Router(config-cmap)# exit
Router(config)# commit

/*Create a service policy map*/

Router(config)# policy-map policy1
Router(config-pmap)# class prec1
Router(config-pmap-c)#police rate 1000 pps burst 300 packets
Router(config-pmap-c-police)#exit
Router(config-pmap-c)#exit
Router(config-pmap)#exit
Router(config)# commit

/*Attach the service policy to an interface*/
Router#int hundredGigE 0/7/0/2
Router(config-if)#service-policy input policy1
Router(config-if)#exit
Router(config)#commit

```

Running Configuration

```

class-map match-any prec1
match precedence 1
end-class-map
!
policy-map policy1
class prec1
  police rate 1000 pps burst 300 packets
  !
!
class class-default
!
end-policy-map
!

```

Verification

```

Router#show qos int hundredGigE 0/7/0/2 input
NOTE:- Configured values are displayed within parentheses
Interface HundredGigE0/7/0/2 ifh 0xe000088 -- input policy
NPU Id: 0
Total number of classes: 2
Interface Bandwidth: 100000000 kbps
Policy Name: policy1
SPI Id: 0x0
Accounting Type: Layer2 (Include Layer 2 encapsulation and above)
-----
Level1 Class = precl

Policer Bucket ID = 0x9
Policer Stats Handle = 0x0
Policer committed rate = 998 kbps (1000 packets/sec)
Policer conform burst = 37632 bytes (300 packets)

Level1 Class = class-default

Default Policer Bucket ID = 0x8
Default Policer Stats Handle = 0x0
Policer not configured for this class

```

Associated Commands

[police rate](#)

Per-thousand and Per-million Units

Shaper and policer rates can be configured in units of per-thousand and per-million on bundle interfaces. This provides the ability to provision shape and police rates down to 100 kbps on bundle or link aggregation (LAG) interfaces even with 100 GE bundle members.

For example, consider a 100GE interface and simple policy.

```

Interface HundredGig0/0/0/0
Service-policy output TEST
Policy-map TEST
Class C
  Shape average per-thousand 5
End-policy

```

Per thousand represents 0.1% of the link bandwidth and per million represents 0.0001% of the link bandwidth.

Which means that for a 100G link, 5 parts per thousand is 0.5% of the link bandwidth. Hence, the shape average per thousand of 5 in the above example enforces a shaper of 500 Mbps.

Shared Policer

Table 44: Feature History Table

Feature Name	Release Information	Feature Description
Shared Policer	Release 7.4.1	This feature is now supported on routers that have Cisco NC57 line cards installed and operate in native and compatibility modes.

The classification of the incoming packet occurs only once. However, based on the different classification criteria, the shared policer feature allows sharing of the policer bucket amongst two or more classes in a QoS policy map. That is, the same token bucket is used for a traffic flow matching against any of the classes sharing the policer.

For example, let us say a policer of 10 Mbps is shared among two classes C1 and C2. This feature ensures that both C1 and C2 get traffic flow assigned on First Come First Serve (FCFS) basis. Also that, if C2 does not have any traffic, C1 uses all of the 10 Mbps for transmission.

This feature includes two components:

- Policer Bucket Shared
- Policer Bucket Referred

Policer Bucket Shared

The policer bucket shared feature defines and shares a policer bucket instance among multiple classes.

Here is a sample configuration that defines and shares policer bucket instance sp1 :

```
policy-map parent
  class long-distance
    police bucket shared sp1 rate 1 mbps
```

In this configuration, a policy-map for class long-distance traffic type is created to police at 1Mbps rate and the policer bucket is shared.

Policer Bucket Referred

The policer bucket referred feature refers a defined policer bucket instance. Shared policer is not supported across policy levels. This means for example, that parent and child policy cannot share a common bucket.

Here is a sample configuration that refers shared policer bucket instance sp1 :

```
policy-map voip-child
  class long-distance-voip
    police bucket referred sp1
```

In this configuration, a policy-map for class long-distance-voip traffic type is created and the shared policer bucket sp1 is referred.

Shared Policer Statistics

Currently, individual class statistics are not available as a default option for shared policer. You can access statistics in the following modes.

Aggregate Mode

In this mode the policer bucket is shared among two or more classes. However, statistics are not available for every individual class. You can view the aggregate statistics that combine the numbers for all the classes sharing the policer bucket.

Per-Class Mode

In this mode the policer bucket is shared among two or more classes, and you can also view individual class statistics. However, when this mode is active, the Policy-Based Tunnel Selection (PBTS) mechanism is

disabled. To enable the per-class mode, you must configure the **hw-module profile qos shared-policer-per-class-stats** command.

Restrictions and Guidelines

The following restrictions and guidelines apply while configuring the shared policer feature.

- When shared policer is enabled in per-class mode, Policy-Based Tunnel Selection (PBTS) mechanism is disabled. In other words, shared policer-per-class-mode and PBTS are mutually exclusive features.
- Shared policer is not supported across policy levels. This means, for example, that parent and child policies cannot share a common policer bucket.
- Shared policer is not supported in ingress peering mode.
- Shared policer is supported within classes of the same policy. However, cross-policy bucket sharing is not supported.
- There are no limitations on the number of classes that can share policer.
- There are no changes in policer scale numbers in the aggregate and per-class modes.
- All the existing policer types (1R2C, 1R3C and 2R3C) are supported.
- You must reload the affected line card to enable the per-class-stats mode.

Configuring Shared Policier

To configure shared policer, you must:

1. Create a class map to be used for matching packets to the specified class.
2. Create a policy map to be used for matching packets to the specified class.
3. Specify a class name.
4. Define and share a policer bucket.
5. Specify a class name.
6. Refer a shared policer bucket.

```
RP/0/RSP0/CPU0:ios(config)#class-map match-any c1
RP/0/RSP0/CPU0:ios(config-cmap)#match precedence 1
RP/0/RSP0/CPU0:ios(config-cmap)#end-class-map
RP/0/RSP0/CPU0:ios(config)#class-map match-any c2
RP/0/RSP0/CPU0:ios(config-cmap)#match precedence 2
RP/0/RSP0/CPU0:ios(config-cmap)#end-class-map
RP/0/RSP0/CPU0:ios(config)#policy-map s-pol
RP/0/RSP0/CPU0:ios(config-pmap)#class c1
RP/0/RSP0/CPU0:ios(config-pmap-c)#police bucket shared 1 rate 10 mbps
RP/0/RSP0/CPU0:ios(config-pmap-c-police)#exit
RP/0/RSP0/CPU0:ios(config-pmap-c)#exit
RP/0/RSP0/CPU0:ios(config-pmap)#class c2
RP/0/RSP0/CPU0:ios(config-pmap-c)#police bucket referred 1
RP/0/RSP0/CPU0:ios(config-pmap-c-police)#class class-default
RP/0/RSP0/CPU0:ios(config-pmap-c)#exit
RP/0/RSP0/CPU0:ios(config-pmap)#exit
RP/0/RSP0/CPU0:ios(config)#interface HundredGigE 0/6/0/18
```

```
RP/0/RSP0/CPU0:ios(config-if)#service-policy input s-pol
RP/0/RSP0/CPU0:ios(config-if)#commit
```

Running Configuration

```
class-map match-any c1
  match precedence 1
end-class-map

class-map match-any c2
  match precedence 2
end-class-map

policy-map s-pol
  class c1
    police bucket shared 1 rate 10 mbps
    !
  !
  class c2
    police bucket referred 1
    !
  !
  class class-default
    !
end-policy-map
!

interface HundredGigE0/6/0/18
  service-policy input s-pol
!
```

Verification

In Aggregate Mode

```
RP/0/RP0/CPU0:ios#sh policy-map interface tenGigE 0/0/0/0 input
Fri Nov 15 12:55:56.817 UTC
```

```
TenGigE0/0/0/0 input: s-pol
```

```
Class c1
  Classification statistics          (packets/bytes)    (rate - kbps)
  Matched                          : 1784530245/228419871360    8640780
  Transmitted                     : 2067504/264640512       10011
  Total Dropped                    : 1782462741/228155230848    8630769
  Policing statistics              (packets/bytes)    (rate - kbps)
  Policed(conform)                 : 2067504/264640512       10011
  Policed(exceed)                  : 1782462741/228155230848    8630769
  Policed(violate)                 : 0/0                      0
  Policed and dropped              : 1782462741/228155230848

Class c2
  Classification statistics          (packets/bytes)    (rate - kbps)
  Matched                          : 0/0                      0
  Transmitted                     : 0/0                    0
  Total Dropped                    : 0/0                      0
  Policing statistics              (packets/bytes)    (rate - kbps)
  Policed(conform)                 : 0/0                      0
  Policed(exceed)                  : 0/0                      0
  Policed(violate)                 : 0/0                      0
  Policed and dropped              : 0/0                      0
Class class-default
  Classification statistics          (packets/bytes)    (rate - kbps)
```

```

    Matched           :                0/0                0
    Transmitted       :                0/0                0
    Total Dropped     :                0/0                0
Policy Bag Stats time: 1573822531986 [Local Time: 11/15/19 12:55:31.986]

```

In Per-Class Mode

```

RP/0/RP0/CPU0:ios#sh policy-map interface tenGigE 0/0/0/0 input
Fri Nov 15 15:18:18.319 UTC

```

```
TenGigE0/0/0/0 input: s-pol
```

```

Class c1
  Classification statistics      (packets/bytes)      (rate - kbps)
  Matched                       :      1005369276/128687267328      4320337
  Transmitted                   :      1163300/148902400           5013
  Total Dropped                 :      1004205976/128538364928      4315324
  Policing statistics           (packets/bytes)      (rate - kbps)
  Policed(conform)              :                1163300/148902400           5013
  Policed(exceed)               :      1004205976/128538364928      4315324
  Policed(violate)              :                0/0                0
  Policed and dropped           :      1004205976/128538364928
Class c2
  Classification statistics      (packets/bytes)      (rate - kbps)
  Matched                       :      1005341342/128683691776      4320335
  Transmitted                   :      1166269/149282432           4997
  Total Dropped                 :      1004175073/128534409344      4315338
  Policing statistics           (packets/bytes)      (rate - kbps)
  Policed(conform)              :                1166269/149282432           4997
  Policed(exceed)               :      1004175073/128534409344      4315338
  Policed(violate)              :                0/0                0
  Policed and dropped           :      1004175073/128534409344
Class class-default
  Classification statistics      (packets/bytes)      (rate - kbps)
  Matched                       :                49159/6292352            0
  Transmitted                   :                49159/6292352            0
  Total Dropped                 :                0/0                0
Policy Bag Stats time: 1573831087338 [Local Time: 11/15/19 15:18:07.338]

```

Related Commands hw-module profile qos shared-policer-per-class-stats

Ingress QoS policer scale enhancement using statistics resource reassignment

An ingress QoS policer scale enhancement using statistics resource reassignment is a QoS policy scale feature that

- increases the maximum number of ingress QoS policers supported per system
- enables policy enforcement across a larger number of ingress L2 subinterfaces, and
- achieves higher policer scale by reallocating statistics resources from other features.

Statistics resource reallocation is the internal mechanism that enables the increased ingress policer scale. It dynamically assigns free and unassigned counter engines—which are organized as statistics banks within the

NPU and used to store per-feature hardware counters—from other features to QoS Rx policer statistics. This mechanism allows the system to expand policer capacity without introducing additional hardware resources.

Table 45: Feature History Table

Feature Name	Release Information	Feature Description
Ingress QoS policer scale enhancement using statistics resource reassignment	Release 25.4.1	<p>Introduced in this release on NCS 5700 fixed port routers (select variants only*)</p> <p>You can now configure a maximum of 64,000 ingress QoS policers. With more QoS policers, you can apply policies on more ingress L2 subinterfaces, improving traffic control and service differentiation at scale.</p> <p>This is achieved by reallocating statistics resources from other features, allowing policer statistics to be assigned where scale demands are highest.</p> <p>Previously, the statistics reassignment command was blocked for policer statistics and could be used only by other features.</p> <p>*This feature is supported on NCS-57C1-48Q6-SYS routers.</p>

Guidelines for configuring ingress QoS policer scale enhancement

- Enable this feature only when high ingress policer scale is required.
- Ensure that unused statistics engines are available before reassignment.
- The QoS policer scale numbers are only applicable when the **hw-module profile mdb l2max** or **hw-module profile mdb l3max** CLI command is enabled. For more information on hardware MDB profiles, see [NCS5700 MDB Profile](#) in the *NCS 5500 System Setup and Software Installation Guide*.
- L2, L3, and tunnel interface configurations are successful even when statistics resources are not available. However, counter visibility may be affected until statistics resources are reassigned.

Limitations for configuring ingress QoS policer scale enhancement

- A statistics bank must be free before it can be reassigned.
- After statistics resource reassignment
 - multicast counters are not available, however multicast functionality is not impacted, and
 - egress ACL statistics may be impacted.

Reverting the statistics resource reassignment to the default allocation restores multicast counters to normal operation.

Configure ingress QoS policer scale enhancement using statistics resource reassignment

Procedure

-
- Step 1** Configure the MDB L2max profile and reload the device.
Configure the hardware MDB profile to enable maximum L2 interface scale, and reload the all the nodes on the router so that the profile takes effect.
- Example:**
- ```
Router# configure
Router(config)# hw-module profile mdb l2max
Router(config)# commit
Router(config)# end
Router# reload location all
```
- The device reloads with the MDB L2max profile configured.
- Step 2** Verify that the MDB L2max profile is active.  
After the device reloads, verify that the MDB profile for L2max is present in the running configuration.
- Example:**
- ```
Router# sh run | in hw
hw-module profile mdb l2max
```
- The output confirms that the MDB L2max profile is configured on the device.
- Step 3** Display statistics resource allocation and identify free counter engines.
Use this command to view the current statistics resource allocation and identify counter engines that are in the `Free` state and available for reassignment.
- Example:**

```
Router# show controllers npu resources stats internal instance all location 0/RP0/CPU0
System information for NPU 0:
Counter Processor Configuration Profile: Default
```

```
=====
Assigned Counter Engine Resource Information
=====
```

Feature	Eng Id	State	Eng Size	Total Counter Entries	Core-0 Entries InUse
trap-aclpolicer	4	In use	4K	2048	147
lpts-pbr	8	In use	8K	4096	53
aclrx-mcrouterx	9	Free	8K	8192	0
acltx	3	Free	4K	4096	0
acltx	15	Free	8K	8192	0
qos rx	23	Free	16K	8192	0
qos rx	24	Free	16K	8192	0
qos rx	25	Free	16K	8192	0
qos rx	26	Free	16K	8192	0
qos rx	27	Free	16K	8192	0
voq	18	In use	16K	8192	70
voq	19	Free	16K	8192	0
voq	20	Free	16K	8192	0
voq	21	Free	16K	8192	0
voq	22	Free	16K	8192	0
l3rx	5	Free	4K	4096	0
l3rx	13	Free	8K	8192	0
l3rx	17	Free	16K	16384	0
mplsrx-l3rxbgppa	1	Free	4K	4096	0
l2rx	16	Free	16K	16384	0
l3tx	6	Free	4K	4096	0
l3tx2	7	In use	4K	2048	54
l2tx-mctx	10	Free	8K	8192	0
l2tx-mctx	11	Free	8K	8192	0
l2tx-mctx	12	Free	8K	8192	0
tetx-srv6loc	2	Free	4K	4096	0
tetx-srv6loc	14	Free	8K	8192	0
POLICER1 (CHILD)	28	Reserved	16K	16384	0
POLICER1 (CHILD)	29	Reserved	16K	16384	0
POLICER1 (CHILD)	30	Reserved	16K	16384	0
POLICER1 (CHILD)	31	Reserved	16K	16384	0
Storm Control Policer	0	Reserved	4K	4096	0

Note: Free and Unassigned Counter engines can be reassigned to other features

You have identified one or more counter engines in the `Free` state that you can reassign to ingress QoS policer statistics.

Note

Ensure target engines are in `Free` state before reassignment.

Step 4 Reassign a free counter engine to the `l2tx-mctx` feature.

Example:

```
Router# configure
Router(config)# stats-resource reassign location 0/RP0/CPU0 internal feature l2tx-mctx eng-ids 2
Router(config)# commit
```

The selected engine is now assigned to the `l2tx-mctx` feature.

Step 5 Reassign free counter engines to the QoS Rx feature.

This step assigns free and unassigned counter engines to the QoS Rx feature to expand ingress QoS policer statistics capacity.

Example:

```
Router# configure
Router(config)# stats-resource reassign location 0/RP0/CPU0 internal feature qosrx eng-ids 3 12 13
14 15 17
Router(config)# commit
```

The selected counter engines are now assigned to the QoS Rx feature and available for ingress QoS policer statistics.

Step 6

Verify the final statistics resource allocation.

Verify that the l2tx-mctx and QoS Rx features are using the reassigned counter engines.

Example:

```
Router# show controllers npu resources stats internal instance all location 0/RP0/CPU0
System information for NPU 0:
Counter Processor Configuration Profile: Default
=====
Assigned Counter Engine Resource Information
=====
```

Feature	Eng Id	State	Eng Size	Total Counter Entries	Core-0 Entries InUse
trap-aclpolicer	4	In use	4K	2048	147
lpts-pbr	8	In use	8K	4096	53
aclrx-mcrouterx	9	Free	8K	8192	0
qos rx	3	Free	4K	2048	0
qos rx	12	Free	8K	4096	0
qos rx	13	Free	8K	4096	0
qos rx	14	Free	8K	4096	0
qos rx	15	Free	8K	4096	0
qos rx	17	Free	16K	8192	0
qos rx	23	Free	16K	8192	0
qos rx	24	Free	16K	8192	0
qos rx	25	Free	16K	8192	0
qos rx	26	Free	16K	8192	0
qos rx	27	Free	16K	8192	0
voq	18	In use	16K	8192	70
voq	19	Free	16K	8192	0
voq	20	Free	16K	8192	0
voq	21	Free	16K	8192	0
voq	22	Free	16K	8192	0
l3rx	5	Free	4K	4096	0
mplsrnx-l3rxbgppa	1	Free	4K	4096	0
l2rx	16	Free	16K	16384	0
l3tx	6	Free	4K	4096	0
l3tx2	7	In use	4K	2048	54
l2tx-mctx	2	Free	4K	4096	0
l2tx-mctx	10	Free	8K	8192	0
l2tx-mctx	11	Free	8K	8192	0
POLICER1 (CHILD)	28	Reserved	16K	16384	0
POLICER1 (CHILD)	29	Reserved	16K	16384	0
POLICER1 (CHILD)	30	Reserved	16K	16384	0
POLICER1 (CHILD)	31	Reserved	16K	16384	0
POLICER2 (PARENT)	32	Reserved	16K	16384	0
Storm Control Policer	0	Reserved	4K	4096	0

Note: Free and Unassigned Counter engines can be reassigned to other features

The output confirms that the QoS Rx feature is using the reassigned statistics resources, and you can revert the reassignment to restore the default allocation if required.

References for Modular QoS Congestion Management

Committed Bursts

The committed burst (bc) parameter of the police command implements the first, conforming (green) token bucket that the router uses to meter traffic. The bc parameter sets the size of this token bucket. Initially, the token bucket is full and the token count is equal to the committed burst size (CBS). Thereafter, the meter updates the token counts the number of times per second indicated by the committed information rate (CIR).

The following describes how the meter uses the conforming token bucket to send packets:

- If sufficient tokens are in the conforming token bucket when a packet arrives, the meter marks the packet green and decrements the conforming token count by the number of bytes of the packet.
- If there are insufficient tokens available in the conforming token bucket, the meter allows the traffic flow to borrow the tokens needed to send the packet. The meter checks the exceeding token bucket for the number of bytes of the packet. If the exceeding token bucket has a sufficient number of tokens available, the meter marks the packet.

Green and decrements the conforming token count down to the minimum value of 0.

Yellow, borrows the remaining tokens needed from the exceeding token bucket, and decrements the exceeding token count by the number of tokens borrowed down to the minimum value of 0.

- If an insufficient number of tokens is available, the meter marks the packet red and does not decrement either of the conforming or exceeding token counts.



Note

When the meter marks a packet with a specific color, there must be a sufficient number of tokens of that color to accommodate the entire packet. Therefore, the volume of green packets is never smaller than the committed information rate (CIR) and committed burst size (CBS). Tokens of a given color are always used on packets of that color.

Excess Bursts

The excess burst (be) parameter of the police command implements the second, exceeding (yellow) token bucket that the router uses to meter traffic. The exceeding token bucket is initially full and the token count is equal to the excess burst size (EBS). Thereafter, the meter updates the token counts the number of times per second indicated by the committed information rate (CIR).

The following describes how the meter uses the exceeding token bucket to send packets:

- When the first token bucket (the conforming bucket) meets the committed burst size (CBS), the meter allows the traffic flow to borrow the tokens needed from the exceeding token bucket. The meter marks the packet yellow and then decrements the exceeding token bucket by the number of bytes of the packet.
- If the exceeding token bucket does not have the required tokens to borrow, the meter marks the packet red and does not decrement the conforming or the exceeding token bucket. Instead, the meter performs the exceed-action configured in the police command (for example, the policer drops the packets).

Two-Rate Policer Details

The committed token bucket can hold bytes up to the size of the committed burst (bc) before overflowing. This token bucket holds the tokens that determine whether a packet conforms to or exceeds the CIR as the following describes:

- A traffic stream is conforming when the average number of bytes over time does not cause the committed token bucket to overflow. When this occurs, the token bucket algorithm marks the traffic stream green.
- A traffic stream is exceeding when it causes the committed token bucket to overflow into the peak token bucket. When this occurs, the token bucket algorithm marks the traffic stream yellow. The peak token bucket is filled as long as the traffic exceeds the police rate.

The peak token bucket can hold bytes up to the size of the peak burst (be) before overflowing. This token bucket holds the tokens that determine whether a packet violates the PIR. A traffic stream is violating when it causes the peak token bucket to overflow. When this occurs, the token bucket algorithm marks the traffic stream red.

For example, if a data stream with a rate of 250 kbps arrives at the two-rate policer, and the CIR is 100 kbps and the PIR is 200 kbps, the policer marks the packet in the following way:

- 100 kbps conforms to the rate
- 100 kbps exceeds the rate
- 50 kbps violates the rate

The router updates the tokens for both the committed and peak token buckets in the following way:

- The router updates the committed token bucket at the CIR value each time a packet arrives at the interface. The committed token bucket can contain up to the committed burst (bc) value.
- The router updates the peak token bucket at the PIR value each time a packet arrives at the interface. The peak token bucket can contain up to the peak burst (be) value.
- When an arriving packet conforms to the CIR, the router takes the conform action on the packet and decrements both the committed and peak token buckets by the number of bytes of the packet.
- When an arriving packet exceeds the CIR, the router takes the exceed action on the packet, decrements the committed token bucket by the number of bytes of the packet, and decrements the peak token bucket by the number of overflow bytes of the packet.
- When an arriving packet exceeds the PIR, the router takes the violate action on the packet, but does not decrement the peak token bucket.

See [Two-Rate Policer](#), on page 192.



CHAPTER 9

Configuring Modular QoS on Link Bundles

This chapter covers the following topics:

- [QoS on Link Bundles, on page 209](#)
- [LAG-level Scheduling in Egress Queuing, on page 215](#)

QoS on Link Bundles

A bundle is a group of one or more ports that are aggregated together and treated as a single link. The router supports Ethernet interfaces and VLAN interfaces (bundle sub-interfaces) bundles. All QoS features currently supported on physical interfaces, are also supported on all link bundle interfaces. Applying QoS on bundle members is not supported.



Note From Cisco IOS XR Release 7.3.1 onwards, systems with Cisco NC57 line cards running in compatibility mode support QoS over Layer 2 services for:

- Local switching [xconnect or bridging]
- L2 VPN – VPWS

Starting with Cisco IOS XR Release 7.4.1 systems with Cisco NC57 line cards running in native mode support QoS over Layer 2 services for:

- Local switching [xconnect or bridging]
 - L2 VPN – VPWS
-

Restrictions for Link Bundles

- Only Ethernet link bundling is supported.
- A bundle interface can only contain physical interface.
- All links within a single bundle must be configured either to run 802.3ad (LACP) or Etherchannel (non-LACP). Mixed links within a single bundle are not supported.
- MAC accounting is not supported on Ethernet link bundles.

- Maximum number of links supported in each link bundle is 64.
- The maximum number of link bundles supported is 128.
- On NCS-57C3-MOD-SYS routers, configuring an egress QoS service policy on a Bundle-Ether interface with a shaper burst size smaller than the interface MTU can cause the bundle interface to go down and stop forwarding traffic.

In this condition, router reloads, line card reloads, and removal or reapplication of the service policy do not restore the bundle interface. Service is restored only after configuring the shaper burst size to a value greater than the bundle interface MTU.

Load Balancing

Load balancing function is a forwarding mechanism to distribute traffic over multiple links based on Layer 3 routing information in the router. Per-destination load balancing is only supported on the router, where the router is allowed to distribute packets over one of the links in the bundle. When the per-destination load balancing is enabled, all packets for a certain source-destination pair go through the same link, though there are multiple links available. In other words, per-destination load balancing can ensure that packets for a certain source-destination pair could arrive in order.

Layer 3 Load Balancing on Link Bundles

Layer 3 load balancing for link bundles is done on Ethernet Flow Points (EFPs) and is based on the IPv4 source and destination addresses in the packet. When Layer 3 service-specific load balancing is configured, all egress bundles are load balanced based on the IPv4 source and destination addresses. When packets do not have IPv4 addresses, default load-balancing (based on the MAC SA/DA fields in the packet header) is used.

Configure QoS on Link Bundles

QoS is configured on link bundles in the same way that it is configured on individual interfaces.

Guidelines

- When a QoS policy is applied on a bundle in the egress direction, it's also applied at each member interface.
- When a QoS policy is applied on a bundle (ingress direction), it's replicated at each NPU core.
- If a QoS policy is not applied to a bundle interface, both the ingress and egress traffic use the default queue of the per link member port.
- The shape rate that is specified in the bundle policy-map is not an aggregate for all bundle members. The shape rate applied to the bundle depends on the load balancing of the links. For example, if a policy map with a shape rate of 10 Mbps is applied to a bundle with two member links, and if the traffic is always load-balanced to the same member link, then an overall rate of 10 Mbps applies to the bundle. However, if the traffic is load-balanced evenly between the two links, the overall shape rate for the bundle becomes 20 Mbps.
- If a member is deleted from a bundle, the total bundle statistics changes because the statistics that belongs to the detached link is lost.

- The QoS policy that is applied on bundle is inherited to all its member links and the reference bandwidth that is used to calculate shaper/bandwidth is applied as per the physical member interface bandwidth, and not the bundle as a whole.

Configuration Example

You have to accomplish the following to complete the QoS configuration on link bundles:



Note The policy works only if it is applied on the ingress direction. The egress is supported on COS, DEI and MPLS exp marking. So the below policy may not work when it is applied on egress.

1. Creating a class-map
2. Creating a policy-map and specifying the respective class-map
3. Specifying the action type for the traffic
Refer [Attach a Traffic Policy to an Interface, on page 29](#) for details on step 1, 2 and 3.
4. Creating a link bundle
5. Applying traffic policy to the link bundle

```
/* Configure Ether-Bundle and apply traffic policy */
Router(config)# interface Bundle-Ether 12000
Router(config-if)# mtu 9100
Router(config-if)# service-policy input ingress
Router(config-if)# service-policy output egress
Router(config-if)# ipv4 address 100.12.0.0 255.255.255.254
Router(config-if)# bundle maximum-active links 64
Router(config-if)# commit
```

Running Configuration

This example shows how a traffic policy is applied on an Ethernet link bundle. The policy is applied to all interfaces that are members of the Ethernet link bundle.

```
/* Policy-map */
policy-map ingress
class inet4-classifier-af1
set qos-group 1
!
class inet4-classifier-af2
set qos-group 2
!
class inet4-classifier-af3
set qos-group 3
!
class inet4-classifier-af4
set qos-group 4
!
class inet4-classifier-bel
set qos-group 5
!
```

```

class inet4-classifier-ncl
  set qos-group 6
!
class class-default
!
end-policy-map
!

/* Ether Bundle */
interface Bundle-Ether12000
  mtu 9100
  service-policy input ingress
  service-policy output egress
  ipv4 address 100.12.0.0 255.255.255.254
  load-interval 30
  flow ipv4 monitor FMM-V4 sampler SM ingress
  flow ipv6 monitor FMM-V6 sampler SM ingress
  flow mpls monitor FMM-MPLS sampler SM ingress
  ipv4 access-group IPV4ACL_101 ingress
  ipv6 access-group IPV6ACL_101 ingress
!

```

Verification

- Verify that the bundle status is UP.

```

router# show bundle bundle-ether 1200
Wed Dec 16 19:55:49.974 PST

Bundle-Ether12000
  Status: Up
  Local links <active/standby/configured>: 35 / 0 / 35
  Local bandwidth <effective/available>: 3500000000 (3500000000) kbps
  MAC address (source): ea3b.745f.c4b0 (Chassis pool)
  Inter-chassis link: No
  Minimum active links / bandwidth: 1 / 1 kbps
  Maximum active links: 64
  Wait while timer: 2000 ms
  Load balancing: Default
  LACP: Operational
    Flap suppression timer: Off
    Cisco extensions: Disabled
    Non-revertive: Disabled
  mLACP: Not configured
  IPv4 BFD: Not configured

  Port          Device      State      Port ID      B/W, kbps
  -----
Hu0/4/0/0      Local      Active     0x8000, 0x0009  100000000
  Link is Active
Hu0/4/0/1      Local      Active     0x8000, 0x000a  100000000
  Link is Active
- - -
Hu0/4/0/35     Local      Active     0x8000, 0x002b  100000000
  Link is Active

```

- Verify the bundle statistics:

```

router# show policy-map interface bundle-ether 12000

```

```

Bundle-Ether12000 input: ingress

Class inet4-classifier-af1
  Classification statistics          (packets/bytes)    (rate - kbps)
  Matched                          : 4647401962/21236124455654    26403040
  Transmitted                       : 4647401962/21236124455654    26403040
  Total Dropped                     : 0/0                          0
Class inet4-classifier-af2
  Classification statistics          (packets/bytes)    (rate - kbps)
  Matched                          : 4502980177/20576584333939    25571493
  Transmitted                       : 4502980177/20576584333939    25571493
  Total Dropped                     : 0/0                          0
Class inet4-classifier-af3
  Classification statistics          (packets/bytes)    (rate - kbps)
  Matched                          : 4647404125/21236213667880    26389086
  Transmitted                       : 4647404125/21236213667880    26389086
  Total Dropped                     : 0/0                          0
Class inet4-classifier-af4
  Classification statistics          (packets/bytes)    (rate - kbps)
  Matched                          : 9291188840/42456120548683    52771168
  Transmitted                       : 9291188840/42456120548683    52771168
  Total Dropped                     : 0/0                          0
Class inet4-classifier-bel
  Classification statistics          (packets/bytes)    (rate - kbps)
  Matched                          : 4647413429/21235847852686    26393414
  Transmitted                       : 4647413429/21235847852686    26393414
  Total Dropped                     : 0/0                          0
Class inet4-classifier-ncl
  Classification statistics          (packets/bytes)    (rate - kbps)
  Matched                          : 9294887621/42473100149807    52778258
  Transmitted                       : 9294887621/42473100149807    52778258
  Total Dropped                     : 0/0                          0

Class class-default
  Classification statistics          (packets/bytes)    (rate - kbps)
  Matched                          : 0/0                          0
  Transmitted                       : 0/0                          0
  Total Dropped                     : 0/0                          0

Bundle-Ether12000 output: egress

Class c1
  Classification statistics          (packets/bytes)    (rate - kbps)
  Matched                          : 16665494532/75878118942463    8760591
  Transmitted                       : 16655834643/75834136022017    8760591
  Total Dropped                     : 9659889/43982920446          0
  Queueing statistics
  Queue ID                          : None (Bundle)
  Taildropped(packets/bytes)        : 9659889/43982920446
Class c2
  Classification statistics          (packets/bytes)    (rate - kbps)
  Matched                          : 16665421959/75877849543188    8718687
  Transmitted                       : 16665421959/75877849543188    8718687
  Total Dropped                     : 0/0                          0
  Queueing statistics
  Queue ID                          : None (Bundle)
  Taildropped(packets/bytes)        : 0/0
Class c3
  Classification statistics          (packets/bytes)    (rate - kbps)
  Matched                          : 16665247833/75877509455458    8703470
  Transmitted                       : 16665187414/75877234624197    8703470
  Total Dropped                     : 60419/274831261             0
  Queueing statistics

```

```

Queue ID                               : None (Bundle)
Taildropped(packets/bytes)             : 60419/274831261
Class c4
Classification statistics               (packets/bytes)   (rate - kbps)
Matched                                : 33330896131/151755393012945   17470745
Transmitted                             : 33330745421/151754709368565   17470745
Total Dropped                            : 150710/683644380              0
Queueing statistics
Queue ID                                 : None (Bundle)
Taildropped(packets/bytes)              : 150710/683644380
Class c5
Classification statistics               (packets/bytes)   (rate - kbps)
Matched                                : 16878910340/76849791869834    8833394
Transmitted                             : 16878849464/76849514633309    8833394
Total Dropped                            : 60876/277236525              0
Queueing statistics
Queue ID                                 : None (Bundle)
Taildropped(packets/bytes)              : 60876/277236525
Class c6
Classification statistics               (packets/bytes)   (rate - kbps)
Matched                                : 33330898844/151756094112925    17456785
Transmitted                             : 33330752668/151755427708382    17456785
Total Dropped                            : 146176/666404543             0
Queueing statistics
Queue ID                                 : None (Bundle)
Taildropped(packets/bytes)              : 146176/666404543
Class c7
Classification statistics               (packets/bytes)   (rate - kbps)
Matched                                : 244106/79922040                74
Transmitted                             : 244106/79922040                74
Total Dropped                            : 0/0                            0
Queueing statistics
Queue ID                                 : None (Bundle)
Taildropped(packets/bytes)              : 0/0
Class class-default
Classification statistics               (packets/bytes)   (rate - kbps)
Matched                                : 267075066180/1215993441123215  139917482
Transmitted                             : 267075066180/1215993441123215  139917482
Total Dropped                            : 0/0                            0
Queueing statistics
Queue ID                                 : None (Bundle)
Taildropped(packets/bytes)              : 0/0

```

Related Topics

- [QoS on Link Bundles, on page 209](#)

Associated Commands

- `bundle maximu-active links`
- `interface Bundle-Ether`

LAG-level Scheduling in Egress Queuing

Table 46: Feature History Table

Feature Name	Release Information	Feature Description
LAG-level Scheduling in Egress Queuing	Release 24.3.1	<p>Introduced in this release on: NCS 5700 fixed port routers; NCS 5500 modular routers (NCS 5700 line cards [Mode: Native])</p> <p>This release enhances traffic management by introducing Link Aggregation Group (LAG) level scheduling improving shaping granularity and scheduler resource efficiency in egress queues for bundle interfaces.</p> <p>Unlike the previous per-member scheduling, where policies are replicated and applied to each individual link in a bundle, LAG-level scheduling applies egress policies to the entire bundle as a single link enabling more precise traffic shaping.</p> <p>The feature introduces these changes:</p> <p>CLI:</p> <ul style="list-style-type: none"> • hw-module profile qos lag-scheduler <p>YANG Data Models:</p> <ul style="list-style-type: none"> • New Xpaths for <code>Cisco-IOS-XR-hw-module-profile-cfg.yang</code> <p>(see GitHub, YANG Data Models Navigator)</p>

LAG-level Scheduler for Egress Queues

LAG-level scheduling is a traffic management feature that applies egress queue policies to an entire Link Aggregation Group (LAG) as a single link, enhancing shaping granularity. This feature supports

- traffic management policies to be applied at the LAG level rather than per member link, and
- flat QoS, Hierarchical QoS (HQoS), and Egress Traffic Management (ETM) mode queuing.

In traditional traffic management systems, policies are applied to each individual link within a link aggregation group or bundle. This per-member approach not only consumes more scheduling resources but also limits the granularity of traffic shaping. For example, in a 2x100G bundle, the policy applied to the bundle gets replicated to each 100G member link, making it difficult to achieve precise traffic shaping. With LAG-level scheduling, the policy is applied to the entire 200G bundle as a single link, significantly enhancing the shaping granularity, allowing for more precise control over traffic flow and better utilization of scheduler resources.

This table helps you understand the key differences between the LAG-level and per-member scheduling features.

Table 47: LAG-level and Per-member Scheduling Features - Key Differences

Attributes	LAG-level Scheduling	Per-member Scheduling
Policy Application	Applies egress queue policies to the entire bundle as a single link.	Applied policy is replicated for each member link.
Scheduling Hierarchy	Tied to the individual NPU core.	Tied to member port.
Shaping Rate	Supports absolute QoS policy shaping rates only.	Supports both absolute and percentage-based QoS policy shaping rates.
Default Status	Configuration required. See Configure LAG-level Scheduling .	Enabled by default.

Use Case Examples:

- **LAG-level scheduling in a single NPU core**—In the traditional bundle-level scheduling, a 2x100G bundle, the policy is replicated to each 100G member link. For a 10-member bundle, traffic is distributed among the members, and a 5 Gbps shaper would effectively become 50 Gbps (5 Gbps x 10).

With this feature, the service policy is applied to the entire bundle as a single interface. For a 10-member bundle, a 5 Gbps shaper limits the entire bundle to 5 Gbps, providing more granular control. This allows network operators to apply precise rate limits for each customer, ensuring better traffic management

- **LAG-level scheduling on members from different NPU cores**—Consider a scenario with two bundle links on different NPU cores and an 8 Gbps shaper. The resultant shaping would be 16 Gbps (8 Gbps x 2). If a third interface from another NPU core is added, the shaping would be 24 Gbps (8 Gbps x 3). This demonstrates the scalability and efficiency of LAG-level scheduling across multiple NPU cores, providing more granular shaping.

LAG-level Scheduling: Usage Guidelines and Restrictions

Usage Guidelines:

After configuring the LAG-level scheduling feature, you must reload the router to activate the profile.

Restrictions:

- LAG-level scheduling is supported for members from different NPU cores with each core having a separate LAG-level TM scheduler. When a LAG contains link members from multiple NPU cores, each core independently manages its portion of the LAG using its own scheduler.

- Only absolute QoS policy shaping rates are supported; percentage rate configurations are not supported in the LAG scheduling mode.
- Default mode (per member scheduling) and LAG-level scheduler mode cannot be used together.
- Port-level burst is not supported for bundle-ethernet (BE) interfaces.
- Port-level shapers are not supported.
- Low-rate shaper enhancement of 0 kbps for shared shapers is not supported with LAG-level scheduling - minimum shaping granularity is 3.9 Mbps.
- Member pinning is not supported, as it aims to avoid limiting a subscriber to a specific member link.

Configure LAG-level Scheduling

Before you begin

Verify the NCS 5700 line card is operating in the native mode.

Procedure

Step 1 Configure LAG-level scheduling for egress queuing.

Example:

```
Router(config)#hw-module profile qos lag-scheduler
router(config)#commit
```

Step 2 Reload the router for the configuration to take effect.

Example:

```
Router#reload location all
```

Step 3 Verify LAG-level scheduling is configured successfully on a bundle interface.

Example:

```
Router#show ofa objects global dump-without-base location 0/1/CPU0 | i lag_scheduler_enable
Mon Aug 26 11:42:09.531 UTC
uint32_t lag_scheduler_enable => 1
```

In the show command output, the `lag_scheduler_enable` parameter is set to 1, which specifies that the LAG-level scheduling mode is active.



CHAPTER 10

Configuring Hierarchical Modular QoS

Hierarchical QoS (H-QoS) is a QoS model that enables you to specify QoS behavior at multiple levels of hierarchy. This chapter provides information about this feature and the different steps involved in configuring it.

Table 48: Feature History for Hierarchical Modular QoS

Release	Modification
Release 6.3.1	Initial Release

This chapter covers the following topics:

- [Overview of Hierarchical Modular QoS, on page 219](#)
- [Restrictions, Limitations, and Requirements for Configuring H-QoS, on page 220](#)
- [Configuring Hierarchical Queuing, on page 222](#)
- [Conform Aware Hierarchical Policy Overview, on page 227](#)

Overview of Hierarchical Modular QoS

Hierarchical QoS (H-QoS) allows you to specify QoS behavior at multiple policy levels, which provides a high degree of granularity in traffic management.

H-QoS is applied on the router interface using nested traffic policies. The first level of traffic policy, the parent traffic policy, is used for controlling the traffic at the main interface or sub-interface level. The second level of traffic policy, the child traffic policy, is used for more control over a specific traffic stream or class. The child traffic policy, is a previously defined traffic policy, that is referenced within the parent traffic policy using the **service-policy** command.

Two-level H-QoS is supported on both ingress and egress directions on all line cards and on physical or bundle main interfaces and sub-interfaces.

Three-level Hierarchical QoS (H-QoS) enables enforcement of class/service, group/ Ethernet Flow Point (EFP), and port level SLAs. You can apply regular two-level egress H-QoS policies on the sub-interfaces to achieve class and EFP SLAs at child and parent levels. In addition, you can apply a port shaper policy on the main interface to achieve an aggregated port level SLA in a 1+2 H-QoS or three-level H-QoS model.

An important point to note is that before Release 6.6.25 (where the three-level H-QoS capability was introduced), when you applied class-default shaper on a main interface, it was enforced *only* on the traffic going through the main interface. With three-level H-QoS, a class default shaper that is applied on the main

interface is considered as a port shaper and enforced on *all* traffic going out of that physical port. The advantage of three-level H-QoS is that the parent shaper on the sub-interfaces is allowed to oversubscribe, thus enabling best effort sharing of the aggregate port shaper at the third level.



Note From Cisco IOS XR Release 7.3.1 onwards, systems with Cisco NC57 line cards running in compatibility mode support QoS over Layer 2 services for:

- Local switching [xconnect or bridging]
- L2 VPN – VPWS

Starting with Cisco IOS XR Release 7.4.1 systems with Cisco NC57 line cards running in native mode support QoS over Layer 2 services for:

- Local switching [xconnect or bridging]
- L2 VPN – VPWS

H-QoS support for EVPN ELAN on Cisco Network Convergence System 5700 Series Routers

Table 49: Feature History Table

Feature Name	Release Information	Feature Description
H-QoS support for EVPN ELAN on Cisco Network Convergence System 5700 Series Routers	Release 7.7.1	<p>You can now apply Hierarchical Modular QoS (H-QoS) on multipoint EVPN service (EVPN ELAN) traffic. You can use H-QoS to specify QoS behavior at multiple levels of hierarchy and allocate specific bandwidth and services to specific users.</p> <p>This feature is now supported on NCS 5700 Series routers operating in native mode (refers to the mode when the router has only NCS 5700 line cards).</p> <p>To enable native mode, use hw-module profile npu native-mode-enable in the configuration mode and reload the router. You can verify this configuration in the show run in hw command output.</p>

Restrictions, Limitations, and Requirements for Configuring H-QoS

There are some key restrictions, limitations, and requirements for configuring H-QoS on your router to ensure optimal performance and compliance.

Parent Traffic Policy Restrictions

- The parent traffic policy only supports the traffic class of type class-default.

- The parent traffic policy only supports the class-action shape, and no other queuing action can be configured in it.
- For congestion avoidance and management, the traffic shaper in the parent traffic policy calculates the queue limit and drop priority

Child Policy Requirements

- While configuring on the router, it is mandatory that the priority class must have a traffic shaper in the child traffic policy.
- The sum of the bandwidth of the child policies must be less than the parent policy's traffic shaper.

H-QoS Profile Limitations

- H-QoS profile and ingress peering profile don't work simultaneously. Hence, features requiring a peering profile also do not work with the H-QoS profile enabled.
- The PBTS feature does not work when the H-QoS profile is enabled. This is due to TCAM limitations.
- A maximum of 896 bundle subinterfaces are supported in the system, even if there are no QoS policies applied. This is due to an internal LAG_ID resource consumption in H-QoS profile mode for bundle subinterfaces with or without QoS policies being applied.
- A maximum of 4 priority levels are supported in H-QoS profile mode, unlike the default mode where 7-priority levels are supported. The restriction also applies to physical and bundle main interface policies where 7-level priorities were previously used in non-H-QoS profile mode.

Bandwidth Configuration Limitations

- Bandwidth and Bandwidth remaining configurations are not supported simultaneously within the same policy-map. If a class has bandwidth (CIR), other classes must also have only bandwidth configuration. If a class-map has bandwidth remaining percent/ratio (EIR), other classes should also have only the bandwidth remaining configuration. Shaping is applied on any class.
- In H-QoS mode, if multiple queues are configured with BRR and there is high congestion in the LP (low-priority) queues, one BRR queue receives more credits than the others. The deviation is proportional to the congestion in the LP queues.
- The granularity of bandwidth or the bandwidth remaining ratio (BRR) is 1:64, compared to 1:4096 in non-H-QoS mode. Consequently, there may be differences in bandwidth performance accuracy depending on the values used.

Priority Classes Requirements

Priority classes must be rate-limited using a shaping configuration. The effective shaper value is used as the priority bandwidth reservation. The total priority bandwidth reservations across all subinterfaces and main interfaces must not exceed the network interface (NIF) port speed to prevent oversubscription of priority traffic. Non-priority class rates and parent shaping can be oversubscribed.

Multicast Traffic Restriction

Filtering egress IPv4 and IPv6 multicast traffic is not supported when H-QoS is configured on the router.

Three-Level H-QoS Restrictions

- There is no support for bandwidth action at the EFP parent level. All EFP and subinterface policies get a fair share of the port shaper.
- Three-level H-QoS does not apply to ingress policies or egress marking policies.
- Executing `clear qos counters` on the main interface clears only the main interface policy statistics. Use the `all` option to clear all sub-interface statistics, or alternatively, clear the sub-interface policy statistics individually.
- Main interface policy statistics do not reflect the subinterface packet or byte counters, although the port shaper is enforced on all logical ports for a given physical interface. The subinterface policy-map statistics reflect the transmitted and dropped packet or byte count post-port shaper enforcement.

Configuring Hierarchical Queuing

Before you configure H-QoS, you must enable the H-QoS profile on the router. After enabling H-QoS profile, reload the router, as shown in the following configuration.

```
admin
hw-module location all reload
Router# configure
Router(config)# hw-module profile qos hqos-enable
Router(config)# commit
Router# admin
sysadmin-vm:0_RP0# hw-module location all reload
```

The steps that are involved in configuring hierarchical queuing are as follows:

1. Configure a class-map.
2. Configure a child traffic policy using the class-map that was configured in the previous step.
3. Configure a parent traffic policy and add the child traffic policy in it.

The parent traffic policy is the H-QoS traffic policy and it can be applied on physical or bundle main interfaces and sub-interfaces.

Configuration Example

Configuration of a class-map is as follows:

```
Router# configure
Router(config)# class-map match-any tc2
Router(config-cmap)# match traffic-class 1
Router(config-cmap)# end-class-map
Router(config)# commit
```

Configuration of a child traffic policy is as follows:

```
Router# configure
Router(config)# policy-map child
Router(config-pmap)# class tc2
Router(config-pmap-c)# shape average percent 20
Router(config-pmap-c)# exit
```

```
Router(config-pmap)# class class-default
Router(config-pmap-c)# shape average percent 1
Router(config-pmap)# end-policy-map
Router(config)# commit
```

Configuration of a parent traffic policy is as follows:

```
Router# configure
Router(config)# policy-map parent
Router(config-pmap)# class class-default
Router(config-pmap-c)# service-policy child
Router(config-pmap-c)# shape average percent 50
Router(config-pmap)# end-policy-map
Router(config)# commit
```

Running Configuration

```
/* Configuration of a Class-map */
class-map match-any tc2
  match traffic-class 1
  end-class-map
!
/* Configuration of a Child Traffic Policy */
policy-map child
  class tc2
    shape average percent 20
  !
  class class-default
    shape average percent 1
  !
  end-policy-map
!
/* Configuration of a Parent Traffic Policy */
policy-map parent
  class class-default
    service-policy child
    shape average percent 50
  !
  end-policy-map
!
```

Applying the Parent Traffic Policy on a Main Interface

```
Router# configure
Router(config)# interface TenGigE 0/0/0/10
Router(config-int)# service-policy output parent
Router(config-int)# commit
```

Applying the Parent Traffic Policy on a Sub-interface

```
Router# configure
Router(config)# interface TenGigE 0/0/0/10.1
Router(config-int)# service-policy output parent
Router(config-int)# commit
```

Verification

Verify if the H-QoS traffic policy is applied correctly on the interface using the commands **show qos interface interface-name output**. In the following example, the **Level1 Class** gives information about the class-map that is associated with the parent traffic policy and the **Level2 Class** gives information about the class-maps that are associated with the child traffic policy.

```
RP/0/RP0/CPU0:ios#show qos interface ten0/0/0/10 output
```

```
NOTE:- Configured values are displayed within parentheses
Interface TenGigE0/0/0/10 ifh 0x1e0 -- output policy
NPU Id:                                0
Total number of classes:                3
Interface Bandwidth:                   10000000 kbps
VOQ Base:                              1136
Accounting Type:                       Layer1 (Include Layer 1 encapsulation and above)
-----
Level1 Class                            = class-default
Queue Max. BW.                          = no max (50 %)
Queue Min. BW.                           = 0 kbps (default)
Inverse Weight / Weight                  = 0 / (BWR not configured)
  Level2 Class                            = tc2
  Egressq Queue ID                       = 1138 (LP queue)
  Queue Max. BW.                          = 1020015 kbps (20 %)
  Queue Min. BW.                           = 0 kbps (default)
  Inverse Weight / Weight                  = 1 / (BWR not configured)
  Guaranteed service rate                 = 1000000 kbps
  TailDrop Threshold                      = 1253376 bytes / 10 ms (default)
  WRED not configured for this class
  Level2 Class                            = class-default
  Egressq Queue ID                       = 1136 (Default LP queue)
  Queue Max. BW.                          = 50625 kbps (1 %)
  Queue Min. BW.                           = 0 kbps (default)
  Inverse Weight / Weight                  = 1 / (BWR not configured)
  Guaranteed service rate                 = 50000 kbps
  TailDrop Threshold                      = 62720 bytes / 10 ms (default)
  WRED not configured for this class
```

The statistics for the packets that have matched the different traffic classes of the parent and child traffic policies can be viewed using the command **show policy-map interface interface-name output**. Also, this command also shows the number of packets that are transmitted or dropped when the specified action is applied on the packets that have matched the respective traffic class.

```
Router# show policy-map interface ten0/0/0/10 output
```

```
TenGigE0/0/0/10 output: parent
Class class-default
Classification statistics          (packets/bytes)      (rate - kbps)
  Matched                          :      2313578823/296138089344      8494665
  Transmitted                       :      232805738/29799134464      854465
  Total Dropped                     :      2080773085/266338954880      7640200
Policy child Class tc2
Classification statistics          (packets/bytes)      (rate - kbps)
  Matched                          :      2313578823/296138089344      8494665
  Transmitted                       :      232805738/29799134464      854465
  Total Dropped                     :      2080773085/266338954880      7640200
Queueing statistics
  Queue ID                          :      1138
  Taildropped (packets/bytes)        :      2080773085/266338954880
Policy child Class class-default
Classification statistics          (packets/bytes)      (rate - kbps)
  Matched                          :      0/0      0
```

```

    Transmitted      :                0/0                0
    Total Dropped    :                0/0                0
Queueing statistics
  Queue ID          : 1136
Taildropped(packets/bytes) : 0/0

```

When using hierarchical policers, there is no independent set of hardware counters to store the parent policer statistics. Instead, parent policer statistics are manipulated in the software to be the sum of all child policers under the same policy-map.

This is shown in the following example where two streams of traffic, with CoS value of 1 and 2 are sent at a speed of 3.5 Gbps each.

```

/*Hierarchical Policy Map Configuration*/
=====
Router# show running-config policy-map Hingress
policy-map Hingress
  class class-default
    service-policy ingress
    police rate 5 gbps peak-rate 9 gbps
  !
  !
end-policy-map
!
/*Ingress Policy Map Configuration*/
=====
Router#show running-config policy-map ingress
policy-map ingress
  class cos1
    set traffic-class 1
    police rate 5 gbps
  !
  !
  class cos2
    set traffic-class 2
    police rate 5 gbps
  !
  !
  class class-default
  !
end-policy-map
!
/*Policy Map applied at TenGigE0/0/0/6.100 Interface*/
=====
Router#show policy-map interface tenGigE 0/0/0/6.100 input

TenGigE0/0/0/6.100 input: Hingress

Class class-default
  Classification statistics          (packets/bytes)      (rate - kbps)
  Matched                          :      856717937/109659895936      6683676
  Transmitted                       :      856717937/109659895936      6683676
  Total Dropped                     :                0/0                0
  Policing statistics              (packets/bytes)      (rate - kbps)
  Policed(conform)                 :      856717937/109659895936      6683674
  Policed(exceed)                  :                0/0                0
  Policed(violate)                 :                0/0                0
  Policed and dropped              :                0/0

Policy ingress Class cos1
  Classification statistics          (packets/bytes)      (rate - kbps)
  Matched                          :      437826303/56041766784      3341838
  Transmitted                       :      437826303/56041766784      3341838

```

```

Total Dropped      :                0/0                0
Policing statistics (packets/bytes) (rate - kbps)
  Policed(conform) :          437826303/56041766784      3341838
  Policed(exceed)  :                0/0                0
  Policed(violate) :                0/0                0
  Policed and dropped :          0/0
  Policed and dropped(parent policer) : 0/0

Policy ingress Class cos2
Classification statistics (packets/bytes) (rate - kbps)
  Matched          :          418891634/53618129152      3341838
  Transmitted      :          418891634/53618129152      3341838
  Total Dropped    :                0/0                0
Policing statistics (packets/bytes) (rate - kbps)
  Policed(conform) :          418891634/53618129152      3341838
  Policed(exceed)  :                0/0                0
  Policed(violate) :                0/0                0
  Policed and dropped :          0/0
  Policed and dropped(parent policer) : 0/0

Policy ingress Class class-default
Classification statistics (packets/bytes) (rate - kbps)
  Matched          :                0/0                0
  Transmitted      :                0/0                0
  Total Dropped    :                0/0                0
Policy Bag Stats time: 0
Policy Bag Stats time: 0

```

Configuration Example for Three-Level H-QoS

To configure three-level H-QoS:

1. Configure the port shaper or EFP group shaper.
2. Configure the two-level H-QoS policy with an EFP parent shaper and class or service level actions
3. Enable the port or EFP group shaper on the main interface to become the root policy.
4. Enable the two-level H-QoS policy on each EFP instance, thus providing a three-level hierarchy of service, EFP and EFP group or port SLAs.

A sample configuration for three-level H-QoS is as follows.

```

policy-map port_shaper
class class-default
  shape average 6 gbps
!
end-policy-map
!

policy-map efp_policy
class class-default
  service-policy efp_policy_child
  shape average 4 gbps
!
end-policy-map

!
policy-map efp_policy_child
class tcl
  shape average 50 mbps
  priority level 1

```

```

!
class tc2
  bandwidth percent 50
!
class tc3
  bandwidth percent 30
!
class class-default
!
end-policy-map
!

interface TenGigE0/5/0/4
  service-policy output port_shaper
!

interface TenGigE0/5/0/4.1
  service-policy output efp_policy
  encapsulation dot1q 11
!

interface TenGigE0/5/0/4.2
  service-policy output efp_policy
  encapsulation dot1q 12
!

```

Verification

Run the **show policy-map interface** command in XR EXEC mode to display the packet/byte count and rate per port shaper enforcement on each of the sub-interface/EFPP policies.

Conform Aware Hierarchical Policy Overview

Hierarchical QoS (H-QoS), while allowing for granular and multi-level management of traffic, does not allow for conform traffic from a child-level policy to a parent-level policy to get priority. This means that in case of excess traffic, the parent policer drops conform traffic packets from the child level as well.

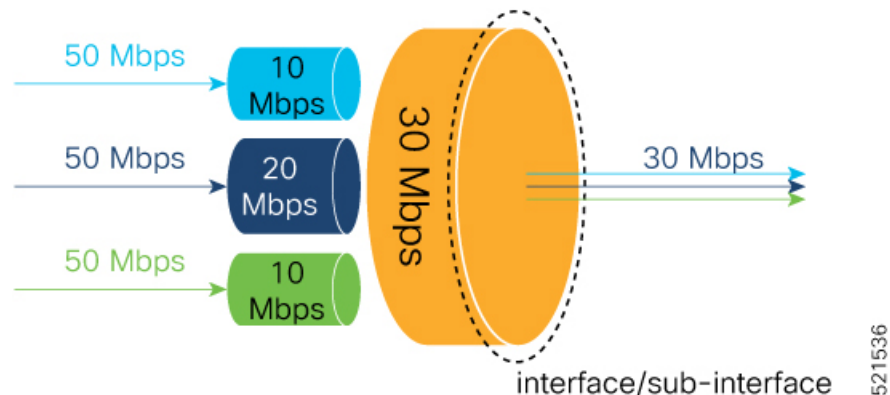

The conform-aware hierarchical policy feature enables the parent-level policy to prioritize conform traffic from child-level policy over exceed and violate traffic.

Here is how it works: the child-level policer initially marks its packets as red, yellow, or green. Packets are marked based on the committed information rate (CIR) value and the two associated burst sizes - committed burst size (CBS) and excess burst size (EBS). If a packet does not exceed the CBS, it is marked as conformed

packet (green). The packet is marked as exceeded if it exceeds CBS, but not the EBS (yellow). If it exceeds the EBS as well, it is marked as violate packet (red).

When the packets arrive at the parent level policer (which is color aware), the policer prioritizes the packets marked green over the packets marked yellow. After all the conform traffic (green) is transmitted and there are tokens available still, the yellow packets are transmitted next, instead of being marked as violate traffic (red).

To enable the conform-aware hierarchical policy feature run the command.

```
hw-module profile qos conform-aware-policer
```

Conform Aware Hierarchical Policy Restrictions

The parent-policy traffic police rate must be greater than or equal to the sum of child conform rates.

Configuring Conform Aware Hierarchy Policy

To enable and configure shared policer:

1. Run the **hw-module profile qos conform-aware-policer** command.
2. Reload the affected line card.
3. Configure class maps to be used for matching packets to the class specified.
4. Create a child policy map.
5. Configure traffic policing for the classes in the child policy map.
6. Attach the child policy-map to the parent's class-default class.
7. Configure traffic policing for the parent policy map.

```
RP/0/RP0/CPU0:ios(config)#hw-module profile qos conform-aware-policer
RP/0/RP0/CPU0:router# reload location 0/0/CPU0
RP/0/RSP0/CPU0:ios(config)#class-map match-any c1
RP/0/RSP0/CPU0:ios(config-cmap)#match precedence 1
RP/0/RSP0/CPU0:ios(config-cmap)#end-class-map
RP/0/RSP0/CPU0:ios(config)#class-map match-any c2
RP/0/RSP0/CPU0:ios(config-cmap)#match precedence 2
RP/0/RSP0/CPU0:ios(config-cmap)#end-class-map
RP/0/RSP0/CPU0:ios(config-pmap)# policy-map child
RP/0/RSP0/CPU0:ios(config-pmap-c)#class class1
RP/0/RSP0/CPU0:ios(config-pmap-c-police)#police rate 20 mbps peak-rate 50 mbps
RP/0/RSP0/CPU0:ios(config-pmap-c)#class class2
RP/0/RSP0/CPU0:ios(config-pmap-c-police)#police rate 30 mbps peak-rate 60 mbps
RP/0/RSP0/CPU0:ios(config-pmap)#policy-map parent
RP/0/RSP0/CPU0:ios(config-pmap-c)#class class-default
RP/0/RSP0/CPU0:ios(config-pmap-c)#service-policy child
RP/0/RSP0/CPU0:ios(config-pmap-c-police)#police rate 60 mbps
RP/0/RSP0/CPU0:ios(config-pmap-c-police)#exit
RP/0/RSP0/CPU0:ios(config-pmap-c)#exit
RP/0/RSP0/CPU0:ios(config-pmap)#exit
RP/0/RSP0/CPU0:ios(config-if)#commit
```

Running Configuration

```
class-map match-any class1
match precedence 1
end-class-map

class-map match-any class2
match precedence 2
end-class-map

policy-map child
class class1
  police rate 20 mbps peak-rate 50 mbps
  !
!
class class2
  police rate 30 mbps peak-rate 60 mbps
  !

policy-map parent
class class-default
  service-policy child
  police rate 60 mbps
!
!
```

In this example, the 20 mbps rate in child class1 and 30 mbps rate in child class2 are guaranteed as conform traffic and the parent will not drop them.

Verification

Run the **show policy-map interface** command in XR EXEC mode to confirm that the committed information rate (CIR) is prioritized over the peak information rate (PIR).

In the example below, **Policed (conform)** or CIR from each class is prioritized over **Policed (exceed)** or PIR.

```
RP/0/RP0/CPU0:ios(config-if)#do show running-config policy-map parent_conform
Tue Apr 28 11:19:09.785 UTC
policy-map parent_conform
class class-default
  service-policy child_conform
  police rate 80 mbps peak-rate 120 mbps
  !
!
end-policy-map
!
```

```
RP/0/RP0/CPU0:ios(config-if)#do show running-config policy-map child_conform
Tue Apr 28 11:19:14.219 UTC
policy-map child_conform
class match_precl
  police rate 30 mbps peak-rate 35 mbps
  !
  set qos-group 3
!
class match_prec2
  police rate 20 mbps peak-rate 25 mbps
  !
  set qos-group 4
!
class class-default
  police rate 20 mbps peak-rate 30 mbps
  !
!
```

```

end-policy-map
!

RP/0/RP0/CPU0:ios(config-if)#do show policy-map interface tenGigE 0/0/0/11/2 input
Tue Apr 28 11:23:48.915 UTC

TenGigE0/0/0/11/2 input: parent_conform

Class class-default
Classification statistics          (packets/bytes)      (rate - kbps)
  Matched                          :      217797200/111512166400      2344847
  Transmitted                       :           8314388/4256966656           88089
  Total Dropped                     :      209482812/107255199744      2256758

Policing statistics               (packets/bytes)      (rate - kbps)
  Policed(conform)                  :           6602174/3380313088           69926
  Policed(exceed)                   :           1712214/876653568            18165
  Policed(violate)                  :      209482812/107255199744      2256782
  Policed and dropped                :      209482812/107255199744

Policy child_conform Class match_prec1
Classification statistics          (packets/bytes)      (rate - kbps)
  Matched                          :      54449300/27878041600           586215
  Transmitted                       :           3246813/1662368256           34399
  Total Dropped                     :      51202487/26215673344           551816
Policing statistics               (packets/bytes)      (rate - kbps)
  Policed(conform)                  :           2818471/1443057152           29851
  Policed(exceed)                   :           428342/219311104            4547
  Policed(violate)                  :      51202487/26215673344           551816
  Policed and dropped                :      51202487/26215673344
  Policed and dropped(parent policer) : 0/0

Policy child_conform Class match_prec2
Classification statistics          (packets/bytes)      (rate - kbps)
  Matched                          :      54449300/27878041600           586213
  Transmitted                       :           2319731/1187702272           24577
  Total Dropped                     :      52129569/26690339328           561636
Policing statistics               (packets/bytes)      (rate - kbps)
  Policed(conform)                  :           1891851/968627712           20037
  Policed(exceed)                   :           427880/219074560            4540
  Policed(violate)                  :      52129569/26690339328           561636
  Policed and dropped                :      52129569/26690339328
  Policed and dropped(parent policer) : 0/0

Policy child_conform Class class-default
Classification statistics          (packets/bytes)      (rate - kbps)
  Matched                          :      108898600/55756083200           1172419
  Transmitted                       :           2747844/1406896128           29113
  Total Dropped                     :      106150756/54349187072          1143306
Policing statistics               (packets/bytes)      (rate - kbps)
  Policed(conform)                  :           1891852/968628224           20036
  Policed(exceed)                   :           855992/438267904            9076
  Policed(violate)                  :      106150756/54349187072          1143306
  Policed and dropped                :      106150756/54349187072
  Policed and dropped(parent policer) : 0/0
Policy Bag Stats time: 1588072996538

```

Related Commands hw-module profile qos conform-aware-policer



CHAPTER 11

Configure Egress Traffic Management

This chapter covers the following topics:

- [Egress Traffic Management, on page 231](#)
- [More About the Egress Traffic Management Model, on page 234](#)
- [QoS Policy Configuration Rules, on page 236](#)
- [Configure Egress Traffic Management , on page 236](#)
- [Low Rate Shaper, on page 252](#)
- [Low Rate Shaper for Enhanced Granularity, on page 255](#)

Egress Traffic Management

Table 50: Feature History Table

Feature Name	Release Information	Feature Description
Egress Traffic Management on NCS-57C3 Fixed Port Routers	Release 24.1.1	<p>Introduced in this release on: NCS 5700 fixed port routers (select variants only*)</p> <p>This model enhances the egress queueing policy by making the feature-rich ingress pipeline available to the outgoing traffic. It also enables the scaling of egress QoS policies by limiting the usage of VOQ connectors on all ingress devices to only physical ports or main interfaces.</p> <p>*This feature is supported on NCS-57C3-MOD-SYS routers.</p>

Feature Name	Release Information	Feature Description
Egress Traffic Management	Release 7.6.1	<p>The egress traffic management model employs a two-pass model per NPU core to get up to 50% of NPU core bandwidth as recycle bandwidth. VOQ lookup takes place in the second pass to get the outgoing interface or sub-interface VOQ. This lookup at the second pass enhances the egress queuing policy by making the feature-rich ingress pipeline available to the outgoing traffic.</p> <p>Also, this functionality is configurable at the port level and not at the global level. This approach limits the usage of VOQ connectors required on all ingress devices to only physical ports or main interfaces, thus enabling scaling of egress QoS policies.</p> <p>This functionality introduces the mode etm option for the controller optics command.</p>

The egress traffic management model modifies the existing [Ingress Traffic Management Model, on page 165](#) to ensure you can configure higher QoS scales. It does so by using a recycle model at egress NPU so that the packet buffering takes place at egress NPU. (See figure, **The Egress Traffic Management Model**.) Also, egress traffic management is configurable at the port-level and not at the global level, to maximize flexibility.

Figure 8: The Egress Traffic Management Model

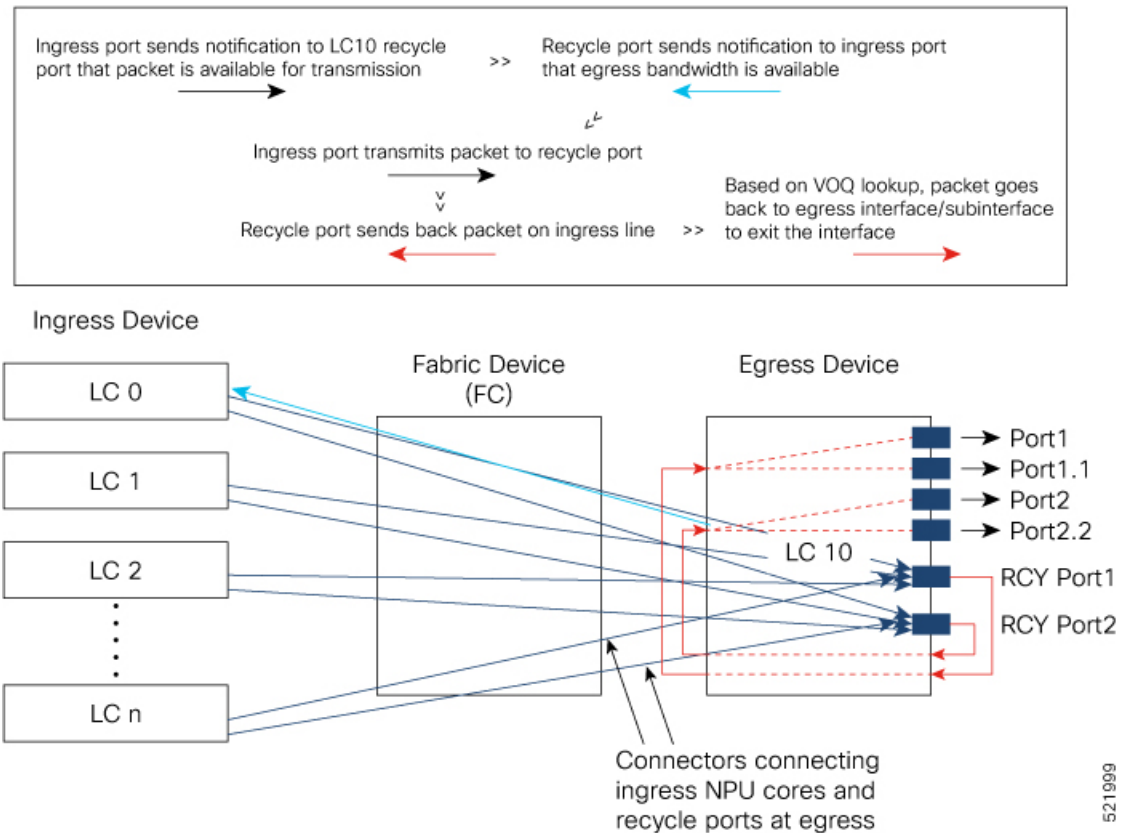

In the figure, every ingress NPU port (LC 0 through LC n) has eight VOQs for the single egress NPU LC 10.

Here's how packet transmission takes place:

1. When a packet arrives at ingress port (say on LC 0), the forwarding lookup on ingress line card points to the egress interface that could be physical, subinterface, Link aggregation Group (LAG), or LAG subinterface. In the case of LAG, hashing takes place at the ingress line card to select the LAG member from where the packet will be sent out. Based on the egress interface (say it is on LC10), the packet is enqueued to the VOQ of LC 10. The egress interface is always mapped to a physical port.
2. However, unlike in the ingress traffic management model where the ingress NPU ports connect to the egress NPU ports (per traffic management hierarchy), the egress traffic management model connects ingress NPU ports to the recycle port that's mapped to the egress port.
3. Once egress bandwidth is available, the recycle ports (based on the packet marking and distribution model) send grants to the ingress ports via the connectors. (The figure shows a separate line for the grant for the sake of visual representation. In reality, the same connector is used for requests, grants, and transmission between an NPU core at the ingress and the corresponding recycle port.)
4. The ingress NPU responds to this permission by transmitting the packet via the fabric device (FC) to the egress NPU.
5. Once the packet reaches egress NPU, it gets recycled back to the ingress pipeline of the egress NPU. A VOQ lookup takes place at this stage that checks if there's a policy on the subinterface. If there's no policy on the subinterface, the main interface VOQ is taken. This behavior is the same as in the ingress traffic

management model, except that another VOQ lookup for subinterface and the main interface takes place in the second pass (recycle) on the egress NPU core.

6. Based on the lookup in the second pass, the packets go back into the egress to the specified main interface or subinterface. It's also in the second pass that any queuing action kicks in before the packets go out the egress interface.

Hardware Limitation:

Even though the traffic rate at the VoQ level is less than that of the VoQ shaper, the router experiences unexpected traffic drops when more than 1000 VoQs (created by egress QoS policies) are holding packets due to active traffic flows and consume all the available on-chip buffers (OCBs).

More About the Egress Traffic Management Model

• Which routers and line cards support the egress traffic management model?

The egress traffic management model is supported on routers that have the following Cisco NC57 line cards that are installed and that operate in the native mode:

- NC57-18DD-SE
- NC57-36H-SE

This feature is also supported on the following Cisco NCS-57B1 chassis variants:

- NCS-57B1-5D24H-SE
- NCS-57B1-5DSE-SYS

From Release 24.1.1, this feature is also supported on the Cisco NCS-57C3 fixed port routers (NCS-57C3-MOD-SYS)

• What benefits does the egress traffic management model offer?

- Configuring the egress traffic management functionality offers you **higher scales of egress QoS policies**. And this is because of the way the egress traffic management model is designed, reducing the size of the mesh of connectors to main and subinterface ingress ports.
- Plus, because of this model (where a second lookup and queuing action takes place in the recycled pass), the **egress queuing policy is enhanced**. An egress traffic management queuing policy contains the same match criteria that ingress policies typically contain. (See the following table for details.) In addition, match on traffic-class and remarking traffic-class is also supported in egress with the **hw-module profile qos ipv6 short-etm** command. (For details, see [Configure Egress Traffic Management](#), on page 236.) This means that the egress traffic management model offers you with even more flexibility in planning your egress policies, while supporting higher scale numbers.

Flow Type	Egress Classification Type Supported
IPv4/IPv6	<ul style="list-style-type: none"> • Prec / DSCP • SIP / DIP / SP / DP / Protocol / TCP-CTL via ACLs • COS / DEI (for VLAN) • Fragmentation
MPLS	<ul style="list-style-type: none"> • IPv4 ToS / IPv6 TC (for underlying for IPv4/IPv6) • COS / DEI (for VLAN) • MPLS Exp
Layer 2	<ul style="list-style-type: none"> • COS / DEI (for VLAN) • COS Inner / DEI Inner (for VLAN) • IPv4 ToS • IPv6 TC • MPLS Exp

- There's another important benefit that the egress traffic management model offers. You need higher QoS scale and features only for access- or edge-facing interfaces, and not on core-facing interfaces. The egress traffic management model provides the **flexibility to configure recycle mode only on access facing ports** while continue using core facing ports in single-pass mode.
- Configuring the egress traffic management functionality enables the low rate shaper feature. For details, see [Low Rate Shaper](#), on page 252.

- **How many VOQs are there on the recycle port per egress interface when ETM is enabled?**—There are eight VOQs on the recycle port per egress interface or sub-interface when ETM is enabled.
- **What is the priority structure of these VOQs?**—VOQs 6-7 are designated as strict (high-priority), whereas VOQs 0-5 are treated as low priority.
- **How is the rate of each recycle port VOQ determined?**—Each recycle port VOQ has a rate equal to the egress port rate. Therefore, the available bandwidth between the recycle port and the egress interface is eight times the egress port rate.
- **What is the buffer size per recycle port VOQ?**—The buffer per recycle port VOQ is 10 ms of the egress port rate.
- **How is traffic assigned to the VOQs?**—Traffic is assigned to the VOQs based on traffic class markings. It is essential to set these markings using a policy on the ingress port.
- **In the recycle pass, packets are sent back on the ingress pipeline. What's the impact?**—The impact is **reduced throughput**. Recycle traffic competes with ingress traffic on the ingress pipeline; this impacts

the traffic throughput. Thus, higher scales come at the cost of reduced throughputs. In such contention cases, device throughput drops down to 50%.

- **How do I handle Link Aggregation Group (LAG) configurations?**—All LAG members must have the same mode. This means that you must **configure the egress traffic management mode on all LAG members**.
- **Which MDB profiles are supported for the egress traffic management model?**—All SE-based MDB profiles are supported for the egress traffic management model. (SE-based MDB profiles are the scaled versions that allow for configuring more QoS policies on systems using eTCAM.)
- **Important Note on LOCP Statistics**—When you attach a policy map to a subinterface in the egress traffic management model, the Locally Originated Control Protocol (LOCP) packets exiting that subinterface are accounted for in the subinterface policy counters.

Without the egress traffic management model, egress inject LOCP packets are not accounted for in sub-interface egress policy counters.

QoS Policy Configuration Rules

- The **set traffic-class** configuration for all traffic classes is mandatory at egress for egress traffic management ports, regardless of your ingress configuration. This **set traffic-class val** represents the VOQ offset that the matching packets select. The only exception to this rule is the class-default configuration.
- The class-default can have a **set traffic-class val** other than 0.
- Even if the ingress and egress traffic classes match, you'll still need to configure a **set traffic-class val** at egress. If the match and set values differ, then the traffic-class is remarked. For example, say a traffic-class is set to 1 in the ingress policy and the match on that traffic-class is 1 on the egress in the egress traffic management policy. Then, say, at the second pass, the **set traffic-class val** is remarked to 5. The packets that match this class in the egress traffic management policy go to VOQ offset 5.
- You can set traffic-class for multiple traffic classes to the same value. In such a situation, traffic matching those classes head to the same VOQ. Therefore, the statistics for all these classes point to the same VOQ counters. It's important to note that when multiple traffic classes have the same value in the **set traffic-class val** action, then the queuing parameters (for example, priority or bandwidth remaining, queue depth, WRED) of these classes **MUST** be the same.
- In a hierarchical policy, you can configure the **set traffic-class val** only for the child traffic classes. The parent classes can't have the **set traffic-class val** action.
- In egress packet recycle scenarios, ensure that the values configured using **set traffic-class** and **set qos-group** are identical in an egress policy-map.

Configure Egress Traffic Management

Before You Begin

Some critical points to note before you begin:

- Before you proceed any further, ensure that you delete your existing **hw-module profile qos hqos-enable** configuration and restart your system. Only then can you enable egress traffic management at the port level. H-QoS profiles and egress traffic management configurations can't coexist.
- The egress traffic management mode is configured on a per-port mode. This ensures that the core-facing ports continue using the current ingress-based VOQ model, while the access ports use the egress traffic management model. Such an approach reduces the consumption of the recycle bandwidth. See the following table for details.

Table 51: Global H-QoS versus Per Port Configuration

Global H-QoS with hw-module profile qos hqos-enable		Per Port Egress Traffic Management (ETM) without hw-module profile qos hqos-enable			
All Ports		ETM ports with controller optics mode etm configured		Non-ETM ports	
Main interface	Subinterface	Main interface	Subinterface	Main interface	Subinterface
H-QoS and flat policies	H-QoS and flat policies	H-QoS and flat policies	H-QoS and flat policies	H-QoS and flat policies	No policies, inherit from main

- The configuration is implemented at the controller level. This means that when you commit the egress traffic management configuration, **all existing configurations are deleted. All existing features and subinterface configurations are deleted and you must reconfigure all of them.**

Configuration Example for Policy Map with Class Match on traffic-class

To configure an egress traffic management queuing policy and reconfigure policies in **etm** mode for traffic class:

1. Delete the existing **hw-module profile qos hqos-enable** configuration and restart your system.
2. Configure NPU native mode by using the **hw-module profile npu native-mode-enable** command.
3. In the admin mode, reload the router by using the **hw-module reload location all** command.
4. Enable egress traffic management (**etm**) on an interface using the **controller optics** command in the optics controller configuration mode. For 10 GbE interfaces, configure **etm** on the breakout port. After this configuration is enabled, it deletes all subinterfaces under the main interface.
5. Configure the subinterfaces. For policy maps with **match-all** specified for **traffic-class**, run **hw-module profile qos ipv6 short-etm** to truncate IPv6 fields. This configuration frees TCAM space for packet header marking for VOQ lookup in the second pass. Reload the line card.
6. Create the class maps.
7. Specify the match criteria, which can be: match on traffic class, DSCP, CoS, or any combination of these criteria.
8. Set the traffic classes for each class in the policy map.



Note The **class-default** need not have a **set-traffic class** value.

9. Specify the traffic class actions.
10. Attach the policy map to the subinterface.

```

/*Delete existing h-qos configuration*/
Router#configure terminal
Router(config)#no hw-module profile qos hqos-enable
In order to activate this new qos profile, you must manually reload the chassis/all line
cards
Router(config)#commit
Router(config)#exit
Router#reload

/* Configure NPU native mode*/
Router#(config)#hw-module profile npu native-mode-enable
In order to activate this new npu profile, you must manually reload the chassis
Router#(config)#commit
Router#(config)#exit
Router#admin
sysadmin-router#hw-module location all reload
Reloading the module will be traffic impacting if not properly drained. Continue to Reload
hardware module ? [no,yes] yes

/*Enable etm on an interface*/
Router#configure terminal
Router(config)#controller optics 0/5/0/16
Router(config-Optics)#mode etm
Router(config-Optics)#commit
Router(config-Optics)#exit

/*To enable etm for breakout ports, as for 10 GbE*/
Router#configure terminal
Router(config)#controller optics 0/5/0/27/1
Router(config-Optics)#mode etm
Router(config-Optics)#commit
Router(config-Optics)#exit

/*Match on traffic-class on ETM-enabled interfaces requires running the following hw-module
command to truncate IPv6 fields, thus freeing TCAM space for packet header marking for
VOQ lookup in the second pass.*/
Router(config)#hw-module profile qos ipv6 short-etm
In order to activate this profile, you must manually reload the chassis/all line cards
Router(config)#commit
Router(config)#exit
Router#reload

/*Configure etm policies on subinterfaces
Configure class map. Specify the match criteria*/
Router(config)#class-map match-any MAIN_OUT_CMAP_1
Router(config-cmap)#match traffic-class 1
Router(config-cmap)#end-class-map
Router(config-cmap)#exit
Router(config)#class-map match-any MAIN_OUT_CMAP_2
Router(config-cmap)#match traffic-class 2
Router(config-cmap)#end-class-map
Router(config-cmap)#exit

```

```

Router(config)#class-map match-any MAIN_OUT_CMAP_3
Router(config-cmap)#match traffic-class 3
Router(config-cmap)#end-class-map
Router(config-cmap)#exit
Router(config)#class-map match-any MAIN_OUT_CMAP_4
Router(config-cmap)#match traffic-class 4
Router(config-cmap)#end-class-map
Router(config-cmap)#exit
Router(config)#class-map match-any MAIN_OUT_CMAP_5
Router(config-cmap)#match traffic-class 5
Router(config-cmap)#end-class-map
Router(config-cmap)#exit
Router(config)#class-map match-any MAIN_OUT_CMAP_6
Router(config-cmap)# match traffic-class 6
Router(config-cmap)#end-class-map
Router(config-cmap)#exit
Router(config)#class-map match-any MAIN_OUT_CMAP_7
Router(config-cmap)#match traffic-class 7
Router(config-cmap)#end-class-map
Router(config-cmap)#exit

/*Create a policy map*/
Router(config)#policy-map MAIN_OUT_PMAP5_PHY_SUB

/*Associate the traffic class with the policy map*/
Router(config-pmap)#class MAIN_OUT_CMAP_1

/*Specify the traffic class actions ('bandwidth remaining ratio, in this example)*/
Router(config-pmap-c)#bandwidth remaining ratio 20
Router(config-pmap-c)#set traffic-class 1
Router(config-cmap-c)#commit
/*Repeat for other classes*/
Router(config-pmap-c)#class MAIN_OUT_CMAP_2
Router(config-pmap-c)#bandwidth remaining ratio 30
Router(config-pmap-c)#set traffic-class 2
Router(config-pmap-c)#exit
Router(config-pmap-c)#class MAIN_OUT_CMAP_3
Router(config-pmap-c)#bandwidth remaining ratio 40
Router(config-pmap-c)#set traffic-class 3
Router(config-pmap-c)#exit
Router(config-pmap-c)#class MAIN_OUT_CMAP_4
Router(config-pmap-c)#bandwidth remaining ratio 50
Router(config-pmap-c)#set traffic-class 4
Router(config-pmap-c)#exit
Router(config-pmap-c)#class MAIN_OUT_CMAP_5
Router(config-pmap-c)#bandwidth remaining ratio 60
Router(config-pmap-c)#set traffic-class 5
Router(config-pmap-c)#exit
Router(config-pmap-c)#class MAIN_OUT_CMAP_6
Router(config-pmap-c)#bandwidth remaining ratio 60
Router(config-pmap-c)#set traffic-class 6
Router(config-pmap-c)#exit
Router(config-pmap-c)#class MAIN_OUT_CMAP_7
Router(config-pmap-c)#set traffic-class 7
Router(config-pmap-c)#priority level 1
Router(config-pmap-c)#exit
Router(config-pmap-c)#class class-default
Router(config-pmap-c)#bandwidth remaining ratio 10
Router(config-pmap-c)#exit
Router(config-pmap-c)#end-policy-map
Router(config)#exit
Router(config)#policy-map PARENT_MAIN_OUT_PHY_SUB

```

```

Router(config-pmap)#class class-default
Router(config-pmap-c)#service-policy MAIN_OUT_PMAP5_PHY_SUB
Router(config-pmap-c)#shape average 55 mbps
Router(config-pmap-c)#exit
Router(config-pmap-c)#end-policy-map
Router(config)#commit

/*Attach the policy map to the subinterface.*/
Router#configure
Router(config)#interface HundredGigE 0/5/0/16.1
Router(config-subif)#service-policy output PARENT_MAIN_OUT_PHY_SUB
Router(config-subif)#commit

```

You have enabled **etm** mode and configured policies in this mode. You are now ready to experience existing QoS features with enhanced egress classification for queuing policy and scale egress queuing policies.

Running Configuration

```

controller Optics 0/5/0/16
  mode etm
!
class-map match-any MAIN_OUT_CMAP_1
  match traffic-class 1
end-class-map
!
class-map match-any MAIN_OUT_CMAP_2
  match traffic-class 2
end-class-map
!
class-map match-any MAIN_OUT_CMAP_3
  match traffic-class 3
end-class-map
!
class-map match-any MAIN_OUT_CMAP_4
  match traffic-class 4
end-class-map
!
class-map match-any MAIN_OUT_CMAP_5
  match traffic-class 5
end-class-map
!
class-map match-any MAIN_OUT_CMAP_6
  match traffic-class 6
end-class-map
!
class-map match-any MAIN_OUT_CMAP_7
  match traffic-class 7
end-class-map
!
policy-map MAIN_OUT_PMAP5_PHY_SUB
  class MAIN_OUT_CMAP_1
    bandwidth remaining ratio 20
    set traffic-class 1
  !
  class MAIN_OUT_CMAP_2
    bandwidth remaining ratio 30
    set traffic-class 2
  !
  class MAIN_OUT_CMAP_3
    bandwidth remaining ratio 40
    set traffic-class 3
  !
  class MAIN_OUT_CMAP_4

```

```

    bandwidth remaining ratio 50
    set traffic-class 4
!
class MAIN_OUT_CMAP_5
    bandwidth remaining ratio 60
    set traffic-class 5
!
class MAIN_OUT_CMAP_6
    bandwidth remaining ratio 60
    set traffic-class 6
!
class MAIN_OUT_CMAP_7
    set traffic-class 7
    priority level 1
!
class class-default
    bandwidth remaining ratio 10
!
end-policy-map
!
policy-map PARENT_MAIN_OUT_PHY_SUB
class class-default
    service-policy MAIN_OUT_PMAP5_PHY_SUB
    shape average 55 mbps
!
end-policy-map

```

Verification

To check if interface is in **etm** mode:

```
Router#show controllers npu voq-usage interface all instance all 1$
```

```

-----
Node ID: 0/0/CPU0
Intf Intf NPU NPU PP Sys VOQ Flow VOQ Port
name handle # core Port Port base base port speed
(hex) type
-----
Hu0/0/0/0 8 0 0 1 24577 38400 6912 local 100G
Hu0/0/0/0 8 0 0 154 1 1536 22272 local 100G ----->2nd Entry points to Recycle Port Mapping

```

To verify the output for policy map with class match on traffic class:

```

Router#show qos interface HundredGigE 0/5/0/16.1 output
NOTE:- Configured values are displayed within parentheses
Interface HundredGigE0/5/0/16.1 ifh 0xa008002 -- output policy
NPU Id: 1
Total number of classes: 9
Interface Bandwidth: 100000000 kbps
Policy Name: PARENT_MAIN_OUT_PHY_SUB
SPI Id: 0x0
VOQ Base: 13328
Accounting Type: Layer1 (Include Layer 1 encapsulation and above)
-----
Level1 Class = class-default
Queue Max. BW. = 70311 kbps (55 mbits/sec)
Queue Min. BW. = 58593 kbps (default)
Inverse Weight / Weight = 1 / (BWR not configured)

Level2 Class = MAIN_OUT_CMAP_1
New traffic class = 1
Egressq Queue ID = 13329 (LP queue)
Queue Max. BW. = no max (default)
Queue Min. BW. = 0 kbps (default)

```

```

Inverse Weight / Weight           = 32 / (20)
Peak burst                         = 36864 bytes (default)
TailDrop Threshold                 = 1280 bytes / 19 ms (default)
WRED not configured for this class

Level2 Class                       = MAIN_OUT_CMAP_2
New traffic class                  = 2
Egressq Queue ID                  = 13330 (LP queue)
Queue Max. BW.                    = no max (default)
Queue Min. BW.                    = 0 kbps (default)
Inverse Weight / Weight           = 21 / (30)
Peak burst                         = 36864 bytes (default)
TailDrop Threshold                 = 1280 bytes / 19 ms (default)
WRED not configured for this class

Level2 Class                       = MAIN_OUT_CMAP_3
New traffic class                  = 3
Egressq Queue ID                  = 13331 (LP queue)
Queue Max. BW.                    = no max (default)
Queue Min. BW.                    = 0 kbps (default)
Inverse Weight / Weight           = 16 / (40)
Peak burst                         = 36864 bytes (default)
TailDrop Threshold                 = 1280 bytes / 19 ms (default)
WRED not configured for this class

Level2 Class                       = MAIN_OUT_CMAP_4
New traffic class                  = 4
Egressq Queue ID                  = 13332 (LP queue)
Queue Max. BW.                    = no max (default)
Queue Min. BW.                    = 0 kbps (default)
Inverse Weight / Weight           = 12 / (50)
Peak burst                         = 36864 bytes (default)
TailDrop Threshold                 = 1280 bytes / 19 ms (default)
WRED not configured for this class

Level2 Class                       = MAIN_OUT_CMAP_5
New traffic class                  = 5
Egressq Queue ID                  = 13333 (LP queue)
Queue Max. BW.                    = no max (default)
Queue Min. BW.                    = 0 kbps (default)
Inverse Weight / Weight           = 10 / (60)
Peak burst                         = 36864 bytes (default)
TailDrop Threshold                 = 1280 bytes / 19 ms (default)
WRED not configured for this class

Level2 Class                       = MAIN_OUT_CMAP_6
New traffic class                  = 6
Egressq Queue ID                  = 13334 (LP queue)
Queue Max. BW.                    = no max (default)
Queue Min. BW.                    = 0 kbps (default)
Inverse Weight / Weight           = 10 / (60)
Peak burst                         = 36864 bytes (default)
TailDrop Threshold                 = 1280 bytes / 19 ms (default)
WRED not configured for this class

Level2 Class (HP1)                 = MAIN_OUT_CMAP_7
New traffic class                  = 7
Egressq Queue ID                  = 13335 (HP1 queue)
Queue Max. BW.                    = no max (default)
Peak burst                         = 36864 bytes (default)
TailDrop Threshold                 = 68608 bytes / 10 ms (default)
WRED not configured for this class

Level2 Class                       = class-default

```

```

Egressq Queue ID           = 13328 (Default LP queue)
Queue Max. BW.             = no max (default)
Queue Min. BW.             = 0 kbps (default)
Inverse Weight / Weight    = 64 / (10)
Peak burst                  = 36864 bytes (default)
TailDrop Threshold         = 1280 bytes / 19 ms (default)

```

Configuration Example for Policy Map with Class Match on DSCP

```

Router(config)#class-map match-any MATCH_DSCP_CONTROL
Router(config-cmap)#description "Customer Control Traffic"
Router(config-cmap)#match dscp 48-58
Router(config-cmap)#end-class-map
Router(config)#class-map match-any MATCH_DSCP_COS1_RT
Router(config-cmap)#description "Real Time Traffic"
Router(config-cmap)#match dscp 40 46
Router(config-cmap)#end-class-map
Router(config)#class-map match-any MATCH_DSCP_COS2_IC
Router(config-cmap)#description "Bursty High In Contract Traffic"
Router(config-cmap)#match dscp 24 26
Router(config-cmap)#end-class-map
Router(config)#class-map match-any MATCH_DSCP_COS2_OC
Router(config-cmap)#description "Bursty High Out of Contract Traffic"
Router(config-cmap)#match dscp 25 27 28 29 30 31
Router(config-cmap)#end-class-map
Router(config)#class-map match-any MATCH_DSCP_COS3_IC
Router(config-cmap)#description "Bursty Low In Contract Traffic"
Router(config-cmap)#match dscp 16 18
Router(config-cmap)#end-class-map
Router(config)#class-map match-any MATCH_DSCP_COS3_OC
Router(config-cmap)#description "Bursty Low Out of Contract Traffic"
Router(config-cmap)#match dscp 17 19 20 21 22 23
Router(config-cmap)#end-class-map
Router(config)#commit

Router(config)#policy-map M4_Ex_1G_Child_80:40:30:30_out_ss
Router(config-pmap)#class MATCH_DSCP_CONTROL
Router(config-pmap-c)#shape average percent 5
Router(config-pmap-c)#set traffic-class 7
Router(config-pmap-c)#priority level 2

Router(config-pmap-c)#class MATCH_DSCP_COS1_RT
Router(config-pmap-c)#shape average percent 80
Router(config-pmap-c)#set traffic-class 5
Router(config-pmap-c)#priority level 1
Router(config-pmap-c)#class MATCH_DSCP_COS2_IC
Router(config-pmap-c)#set traffic-class 2
Router(config-pmap-c)#bandwidth remaining percent 40
Router(config-pmap-c)#queue-limit 4096 packets
Router(config-pmap-c)#class MATCH_DSCP_COS3_IC
Router(config-pmap-c)#bandwidth remaining percent 30
Router(config-pmap-c)#set traffic-class 3
Router(config-pmap-c)#queue-limit 3072 packets
Router(config-pmap-c)#class class-default
Router(config-pmap-c)#bandwidth remaining percent 30
Router(config-pmap-c)#set traffic-class 0
Router(config-pmap-c)#queue-limit 3072 packets
Router(config-pmap-c)#end-policy-map
Router(config)#policy-map M4_Ex_1G_80:40:30:30_out_ss
Router(config-pmap)#class class-default
Router(config-pmap-c)#service-policy M4_Ex_1G_Child_80:40:30:30_out_ss
Router(config-pmap-c)#shape average 100 mbps

```

```

Router(config-pmap-c)#commit
Router(config-pmap-c)#exit
Router(config-pmap)#exit
Router(config)#interface HundredGigE 0/5/0/16.1
Router(config-subif)#service-policy output M4_Ex_1G_80:40:30:30_5
Router(config-subif)#commit

```

Running Configuration

```

class-map match-any MATCH_DSCP_CONTROL
description "Customer Control Traffic"
match dscp 48-58
end-class-map
!
class-map match-any MATCH_DSCP_COS1_RT
description "Real Time Traffic"
match dscp 40 46
end-class-map
!
class-map match-any MATCH_DSCP_COS2_IC
description "Bursty High In Contract Traffic"
match dscp 24 26
end-class-map
!
class-map match-any MATCH_DSCP_COS3_IC
description "Bursty Low In Contract Traffic"
match dscp 16 18
end-class-map
!
policy-map M4_Ex_1G_Child_80:40:30:30_out_ss
class MATCH_DSCP_CONTROL
shape average percent 5
set traffic-class 7
priority level 2
!
class MATCH_DSCP_COS1_RT
shape average percent 80
set traffic-class 5
priority level 1
!
class MATCH_DSCP_COS2_IC
set traffic-class 2
bandwidth remaining percent 40
queue-limit 4096 packets
!
class MATCH_DSCP_COS3_IC
bandwidth remaining percent 30
set traffic-class 3
queue-limit 3072 packets
!
class class-default
bandwidth remaining percent 30
set traffic-class 0
queue-limit 3072 packets
!
end-policy-map
!
policy-map M4_Ex_1G_80:40:30:30_out_ss
class class-default
service-policy M4_Ex_1G_Child_80:40:30:30_out_ss
shape average 100 mbps
!
end-policy-map

```

Verify the Output for Policy Map with Class Match on DSCP

```

Router#show qos interface HundredGigE 0/5/0/16.1 output
NOTE:- Configured values are displayed within parentheses
Interface HundredGigE0/5/0/16.1 ifh 0xa008002 -- output policy
NPU Id: 1
Total number of classes: 6
Interface Bandwidth: 100000000 kbps
Policy Name: M4_Ex_1G_80:40:30:30_out_ss
SPI Id: 0x0
VOQ Base: 13328
Accounting Type: Layer1 (Include Layer 1 encapsulation and above)
-----
Level1 Class = class-default
Queue Max. BW. = 113282 kbps (100 mbits/sec)
Queue Min. BW. = 101564 kbps (default)
Inverse Weight / Weight = 1 / (BWR not configured)

Level2 Class (HP2) = MATCH_DSCP_CONTROL
New traffic class = 7
Egressq Queue ID = 13335 (HP2 queue)
Queue Max. BW. = 7812 kbps (5 %)
Guaranteed service rate = 5000 kbps
Peak burst = 36864 bytes (default)
TailDrop Threshold = 6144 bytes / 10 ms (default)
WRED not configured for this class

Level2 Class (HP1) = MATCH_DSCP_COS1_RT
New traffic class = 5
Egressq Queue ID = 13333 (HP1 queue)
Queue Max. BW. = 82031 kbps (80 %)
Guaranteed service rate = 80000 kbps
Peak burst = 36864 bytes (default)
TailDrop Threshold = 99840 bytes / 10 ms (default)
WRED not configured for this class

Level2 Class = MATCH_DSCP_COS2_IC
New traffic class = 2
Egressq Queue ID = 13330 (LP queue)
Queue Max. BW. = no max (default)
Queue Min. BW. = 0 kbps (default)
Inverse Weight / Weight = 2 / (40%)
Guaranteed service rate = 6000 kbps
Peak burst = 36864 bytes (default)
TailDrop Threshold = 1048576 bytes / 1398 ms (4096 packets)
WRED not configured for this class

Level2 Class = MATCH_DSCP_COS3_IC
New traffic class = 3
Egressq Queue ID = 13331 (LP queue)
Queue Max. BW. = no max (default)
Queue Min. BW. = 0 kbps (default)
Inverse Weight / Weight = 2 / (30%)
Guaranteed service rate = 4500 kbps
Peak burst = 36864 bytes (default)
TailDrop Threshold = 786432 bytes / 1398 ms (3072 packets)
WRED not configured for this class

Level2 Class = class-default
New traffic class = 0
Egressq Queue ID = 13328 (Default LP queue)
Queue Max. BW. = no max (default)
Queue Min. BW. = 0 kbps (default)
Inverse Weight / Weight = 2 / (30%)

```

```

Guaranteed service rate           = 4500 kbps
Peak burst                         = 36864 bytes (default)
TailDrop Threshold                 = 786432 bytes / 1398 ms (3072 packets)
WRED not configured for this class

```

Configuration Example for Policy Map with Class Match on COS

```

Router(config)#class-map match-any cos2
  Router(config-cmap)#match cos 2
Router(config-cmap)#end-class-map
Router(config)#class-map match-all cos3
Router(config-cmap)#match cos 3
Router(config-cmap)#end-class-map
Router(config)#class-map match-all cos4
Router(config-cmap)#match cos 4
Router(config-cmap)#end-class-map
Router(config)#class-map match-all cos5
Router(config-cmap)#match cos 5
Router(config-cmap)#end-class-map
Router(config)#class-map match-all cos6
Router(config-cmap)#match cos 6
Router(config-cmap)#end-class-map
Router(config)#class-map match-all cos7
Router(config-cmap)#match cos 7
Router(config-cmap)#end-class-map
Router(config)#class-map match-all cos1
Router(config-cmap)#match cos 1
Router(config-cmap)#end-class-map
Router(config)#policy-map L2VPN-OUT
Router(config-pmap)#class cos2
Router(config-pmap-c)#set traffic-class 2
Router(config-pmap-c)#shape average 45 mbps
Router(config-pmap-c)#class cos3
Router(config-pmap-c)#set traffic-class 3
Router(config-pmap-c)#shape average 50 mbps
Router(config-pmap-c)#class cos4
Router(config-pmap-c)#set traffic-class 4
Router(config-pmap-c)#shape average 50 mbps
Router(config-pmap-c)#class cos5
Router(config-pmap-c)#set traffic-class 5
Router(config-pmap-c)#shape average 50 mbps
Router(config-pmap-c)#class cos6
Router(config-pmap-c)#set traffic-class 6
Router(config-pmap-c)#shape average 50 mbps
Router(config-pmap-c)#class cos7
Router(config-pmap-c)#set traffic-class 7
Router(config-pmap-c)#shape average 50 mbps
Router(config-pmap-c)#class cos1
Router(config-pmap-c)#set traffic-class 1
Router(config-pmap-c)#shape average 50 mbps
Router(config-pmap-c)#class class-default
Router(config-pmap-c)#shape average 50 mbps
Router(config-pmap-c)#end-policy-map
Router(config)#commit
Router(config)#exit

Router(config)#interface HundredGigE 0/5/0/16.1
Router(config-subif)#no service-policy output
Router(config-subif)#commit

Router(config-subif)#service-policy output L2VPN-OUT

```

```
Router(config-subif)#commit
Router(config-subif)#end
```

Running Configuration

```
class-map match-any cos2
  match cos 2
end-class-map
!
class-map match-all cos3
  match cos 3
end-class-map
!
class-map match-all cos4
  match cos 4
end-class-map
!
class-map match-all cos5
  match cos 5
end-class-map
!
class-map match-all cos6
  match cos 6
end-class-map
!
class-map match-all cos7
  match cos 7
end-class-map
!
class-map match-all cos1
  match cos 1
end-class-map
!
class-map match-any class-default
end-class-map
!
policy-map L2VPN-OUT
  class cos2
    set traffic-class 2
    shape average 45 mbps
  !
  class cos3
    set traffic-class 3
    shape average 50 mbps
  !
  class cos4
    set traffic-class 4
    shape average 50 mbps
  !
  class cos5
    set traffic-class 5
    shape average 50 mbps
  !
  class cos6
    set traffic-class 6
    shape average 50 mbps
  !
  class cos7
    set traffic-class 7
    shape average 50 mbps
  !
  class cos1
    set traffic-class 1
    shape average 50 mbps
  !
```

```

class class-default
  shape average 50 mbps
!
end-policy-map

```

Verify the Output for Policy Map with Class Match on COS

```

Router#show qos interface HundredGigE 0/5/0/16.1 output
NOTE:- Configured values are displayed within parentheses
Interface HundredGigE0/5/0/16.1 ifh 0xa008002 -- output policy
NPU Id: 1
Total number of classes: 8
Interface Bandwidth: 100000000 kbps
Policy Name: L2VPN-OUT
SPI Id: 0x0
VOQ Base: 13328
Accounting Type: Layer1 (Include Layer 1 encapsulation and above)
-----
Level1 Class = cos2
New traffic class = 2
Egressq Queue ID = 13330 (LP queue)
Queue Max. BW. = 46875 kbps (45 mbits/sec)
Queue Min. BW. = 0 kbps (default)
Inverse Weight / Weight = 1 / (BWR not configured)
Guaranteed service rate = 45000 kbps
Peak burst = 36864 bytes (default)
TailDrop Threshold = 56064 bytes / 10 ms (default)
WRED not configured for this class

Level1 Class = cos3
New traffic class = 3
Egressq Queue ID = 13331 (LP queue)
Queue Max. BW. = 50781 kbps (50 mbits/sec)
Queue Min. BW. = 0 kbps (default)
Inverse Weight / Weight = 1 / (BWR not configured)
Guaranteed service rate = 50000 kbps
Peak burst = 36864 bytes (default)
TailDrop Threshold = 62464 bytes / 10 ms (default)
WRED not configured for this class

Level1 Class = cos4
New traffic class = 4
Egressq Queue ID = 13332 (LP queue)
Queue Max. BW. = 50781 kbps (50 mbits/sec)
Queue Min. BW. = 0 kbps (default)
Inverse Weight / Weight = 1 / (BWR not configured)
Guaranteed service rate = 50000 kbps
Peak burst = 36864 bytes (default)
TailDrop Threshold = 62464 bytes / 10 ms (default)
WRED not configured for this class

Level1 Class = cos5
New traffic class = 5
Egressq Queue ID = 13333 (LP queue)
Queue Max. BW. = 50781 kbps (50 mbits/sec)
Queue Min. BW. = 0 kbps (default)
Inverse Weight / Weight = 1 / (BWR not configured)
Guaranteed service rate = 50000 kbps
Peak burst = 36864 bytes (default)
TailDrop Threshold = 62464 bytes / 10 ms (default)
WRED not configured for this class

Level1 Class = cos6
New traffic class = 6
Egressq Queue ID = 13334 (LP queue)

```

```

Queue Max. BW.                = 50781 kbps (50 mbits/sec)
Queue Min. BW.                = 0 kbps (default)
Inverse Weight / Weight      = 1 / (BWR not configured)
Guaranteed service rate     = 50000 kbps
Peak burst                    = 36864 bytes (default)
TailDrop Threshold          = 62464 bytes / 10 ms (default)
WRED not configured for this class

Levell Class                  = cos7
New traffic class             = 7
Egressq Queue ID             = 13335 (LP queue)
Queue Max. BW.               = 50781 kbps (50 mbits/sec)
Queue Min. BW.               = 0 kbps (default)
Inverse Weight / Weight      = 1 / (BWR not configured)
Guaranteed service rate     = 50000 kbps
Peak burst                    = 36864 bytes (default)
TailDrop Threshold          = 62464 bytes / 10 ms (default)
WRED not configured for this class

Levell Class                  = cos1
New traffic class             = 1
Egressq Queue ID             = 13329 (LP queue)
Queue Max. BW.               = 50781 kbps (50 mbits/sec)
Queue Min. BW.               = 0 kbps (default)
Inverse Weight / Weight      = 1 / (BWR not configured)
Guaranteed service rate     = 50000 kbps
Peak burst                    = 36864 bytes (default)
TailDrop Threshold          = 62464 bytes / 10 ms (default)
WRED not configured for this class

Levell Class                  = class-default
Egressq Queue ID             = 13328 (Default LP queue)
Queue Max. BW.               = 50781 kbps (50 mbits/sec)
Queue Min. BW.               = 0 kbps (default)
Inverse Weight / Weight      = 1 / (BWR not configured)
Guaranteed service rate     = 50000 kbps
Peak burst                    = 36864 bytes (default)
TailDrop Threshold          = 62464 bytes / 10 ms (default)
WRED not configured for this class

```

Configuration Example for Policy Map with Class Match on Traffic Class and DSCP

```

Router(config)#class-map match-any cm-dscp-cs1
Router(config-cmap)#match dscp cs1
Router(config-cmap)#class-map match-any cm-dscp-cs2
Router(config-cmap)#match dscp cs2
Router(config-cmap)#class-map match-any cm-dscp-af11
Router(config-cmap)#match dscp af11
Router(config-cmap)#class-map match-any cm-tc-5
Router(config-cmap)#match traffic-class 5
Router(config-cmap)#class-map match-all cm-tc-6-and-dscp-cs3
Router(config-cmap)#match traffic-class 6
Router(config-cmap)#match dscp cs3
Router(config-cmap)#policy-map pm-out-etm-queueing
Router(config-pmap)#class cm-dscp-cs1
Router(config-pmap-c)#set traffic-class 1
Router(config-pmap-c)#shape average percent 45
Router(config-pmap-c)#class cm-dscp-cs2
Router(config-pmap-c)#set traffic-class 1
Router(config-pmap-c)#shape average percent 45
Router(config-pmap-c)#class cm-dscp-af11
Router(config-pmap-c)#set traffic-class 2

```

```

Router(config-pmap-c)#shape average percent 10
Router(config-pmap-c)#class cm-tc-5
Router(config-pmap-c)#shape average percent 5
Router(config-pmap-c)#set traffic-class 3
Router(config-pmap-c)#class cm-tc-6-and-dscp-cs3
Router(config-pmap-c)#set traffic-class 7
Router(config-pmap-c)#priority
Router(config-pmap-c)#commit
Router(config-pmap-c)#exit
Router(config-pmap)#exit
Router(config)#interface HundredGigE 0/5/0/16.1
Router(config-subif)#service-policy output pm-out-etm-queueing
Router(config-subif)#commit
Router(config-subif)#end

```

Running Configuration

```

class-map match-any cm-dscp-cs1
match dscp cs1
end-class-map
!
class-map match-any cm-dscp-cs2
match dscp cs2
end-class-map
!
class-map match-any cm-dscp-af11
match dscp af11
end-class-map
!
class-map match-any cm-tc-5
match traffic-class 5
end-class-map
!
class-map match-all cm-tc-6-and-dscp-cs3
match traffic-class 6
match dscp af22 cs3
end-class-map
!
policy-map pm-out-etm-queueing
class cm-dscp-cs1
set traffic-class 1
shape average percent 45
!
class cm-dscp-cs2
set traffic-class 1
shape average percent 45
!
class cm-dscp-af11
set traffic-class 2
shape average percent 10
!
class cm-tc-5
shape average percent 5
set traffic-class 3
!
class cm-tc-6-and-dscp-cs3
set traffic-class 7
priority level 1
!
class class-default
!
end-policy-map

```

Notes on the Configuration Example

- Both the traffic classes **cm-dscp-cs1** and **cm-dscp-cs2** have the same action for set traffic-class in the EM mode, which is **set traffic-class 1**. This means that both these classes have matching traffic going to the same VOQ, and hence their statistics refer to the statistics for VOQ=1.
- The traffic class **cm-dscp-af11** has the action set traffic-class 2 at the recycle pass in the ETM mode. Hence, its matching traffic and statistics are from VOQ=2.
- The traffic class **cm-tc-6-and-dscp-cs3** is an example of remarking traffic-class. This class has traffic-class=6 configured at the ingress, and matches all traffic that has incoming traffic-class=6 AND incoming DSCP=CS3. However, at egress, the traffic-class is remarked to 7. Hence, matching traffic goes to VOQ=7, and the statistics for this class are taken from VOQ=7.

Verify the Output for Policy Map with Class Match on Traffic Class and DSCP

```

Router#show qos interface HundredGigE 0/5/0/16.1 output
NOTE:- Configured values are displayed within parentheses
Interface HundredGigE0/5/0/16.1 ifh 0xa008002 -- output policy
NPU Id: 1
Total number of classes: 6
Interface Bandwidth: 100000000 kbps
Policy Name: pm-out-etm-queueing
SPI Id: 0x0
VOQ Base: 13328
Accounting Type: Layer1 (Include Layer 1 encapsulation and above)
-----
Level1 Class = cm-dscp-cs1
New traffic class = 1
Egressq Queue ID = 13329 (LP queue)
Queue Max. BW. = 45003261 kbps (45 %)
Queue Min. BW. = 0 kbps (default)
Inverse Weight / Weight = 1 / (BWR not configured)
Peak burst = 36864 bytes (default)
TailDrop Threshold = 1249792 bytes / 10 ms (default)
WRED not configured for this class

Level1 Class = cm-dscp-cs2
New traffic class = 1
Egressq Queue ID = 13329 (LP queue)
Queue Max. BW. = 45003261 kbps (45 %)
Queue Min. BW. = 0 kbps (default)
Inverse Weight / Weight = 1 / (BWR not configured)
Peak burst = 36864 bytes (default)
TailDrop Threshold = 1249792 bytes / 10 ms (default)
WRED not configured for this class

Level1 Class = cm-dscp-af11
New traffic class = 2
Egressq Queue ID = 13330 (LP queue)
Queue Max. BW. = 10000152 kbps (10 %)
Queue Min. BW. = 0 kbps (default)
Inverse Weight / Weight = 1 / (BWR not configured)
Peak burst = 36864 bytes (default)
TailDrop Threshold = 1249792 bytes / 10 ms (default)
WRED not configured for this class

Level1 Class = cm-tc-5
New traffic class = 3
Egressq Queue ID = 13331 (LP queue)
Queue Max. BW. = 5000076 kbps (5 %)
Queue Min. BW. = 0 kbps (default)
Inverse Weight / Weight = 1 / (BWR not configured)
Peak burst = 36864 bytes (default)

```

```

TailDrop Threshold = 1249792 bytes / 10 ms (default)
WRED not configured for this class

Level1 Class (HP1) = cm-tc-6-and-dscp-cs3
New traffic class = 7
Egressq Queue ID = 13335 (HP1 queue)
Queue Max. BW. = no max (default)
Peak burst = 36864 bytes (default)
TailDrop Threshold = 124999936 bytes / 10 ms (default)
WRED not configured for this class

Level1 Class = class-default
Egressq Queue ID = 13328 (Default LP queue)
Queue Max. BW. = no max (default)
Queue Min. BW. = 0 kbps (default)
Inverse Weight / Weight = 1 / (BWR not configured)
Peak burst = 36864 bytes (default)
TailDrop Threshold = 1249792 bytes / 10 ms (default)
WRED not configured for this class

```

Associated Commands

```
controller optics
```

Low Rate Shaper

Table 52: Feature History Table

Feature Name	Release Information	Feature Description
Low Rate Shaper	Release 7.6.1	<p>This functionality allows your hardware to program low shaper bandwidth with accuracy. Earlier, if one of your customers wanted, say, a bandwidth of 500 kbps, the Cisco NC 57 line card ASIC could only program a minimum bandwidth of 3.9 Mbps for a particular traffic class, resulting in unnecessary wastage of bandwidth. With low shaper rates now made possible, you can limit bandwidth for specific subscribers whose requirements don't call for excessive bandwidth. This functionality thus allows you to save on your bandwidth costs.</p> <p>This functionality is only available for and automatically enabled in the egress traffic management mode.</p>

- **What is the low rate shaper functionality all about?**—As the name suggests, the functionality is about providing accurate low shaper rate (less than 5 Mbps). But the powerful aspect of this feature is that the low shaper rates that it enables are far lesser what your existing Cisco NC 57 line card ASICs allow.

This functionality is available only when you configure your egress interface in the Egress Traffic Management (Egress TM) mode. It's automatically enabled in this mode.

- **What are the benefits of this functionality?**—This functionality is supported on Cisco NC 57 line cards. The forwarding ASIC in this line card is capable of supporting only 3.9 Mbps as the lowest rate for a particular traffic class, even if you configure a shaping bandwidth less than 3.9 Mbps. When you have a typical network set up that has hundreds of edge-facing routers and thousands of interfaces, this restriction meant that excess bandwidth was distributed even to those subscribers who didn't require it, and hence didn't pay for it.

With this functionality, you can save on your bandwidth costs by limiting the bandwidth for specific subscribers who require a lower spectrum of capacities. Hence, the low-rate shaper also provides you with more accuracy in shaping your hardware's bandwidth. The result is optimal bandwidth distribution and savings for your operations.

- **How does this functionality work? Any important points?**

- When you configure a shaper rate of any value below 5 MBps for the virtual output queue (VOQ) of an ETM-enabled egress interface, the system automatically shifts into low-rate shaper mode.
- Once in low-rate shaper mode, your system supports traffic shaping rates to a particular VOQ in a specific range. This range is from 122 kbps through 80 Gbps.
- To support low-shaping capability, you need to reserve low-rate connectors. The system has 64 connector regions and each region contains 1024 connectors.
- Low connectors get allocated statically during system initialization, and the allocation can't be changed dynamically. You can't use connectors that are reserved and configured as low connectors, as normal connectors, and the converse holds good as well.
- You have the flexibility to reserve the required connectors for low and normal regions before applying all QoS policies at egress.
- A connector switches from low to normal or the other way around if:
 - a low shaper rate (less than 5 Mbps) is detected on any of the traffic classes (VOQ) of an interface, where egress QoS policy map is applied. In this case, all the eight normal connectors are replaced by low connectors.
 - post-policy update or removal, no low shaper rate (less than 5 Mbps) is detected on an egress QoS Policy Map that is applied on VOQs attached with low connectors. In this case, low connectors are replaced by normal connectors.

- **How many egress policy maps can I configure with low rate shaper?**

By default, 2 connector regions per core are reserved for low connectors.

Therefore, per core, the number of low rate connectors are: number of low rate connectors per region x number of connector regions per core = 1024 x 2 = **2048**

Each interface VOQ set requires **8** connectors (or 8 traffic classes).

Therefore, the number of interface VOQ sets (or policy maps) that you can configure per core = number of low rate connectors/number of connectors per interface VOQ set = 2048/8 = **256**

- **Any limitations or restrictions?**

- A low connector can't support more than 80 Gbps traffic shaping rate. Which means that a VOQ attached to a low connector can't forward more than 80 Gbps of traffic.
- Attaching and detaching low connector sets to and from egress interfaces impacts traffic flows in unrelated VOQs. This could affect traffic flows when connectors are switched.
- This functionality is applicable only for local switching on an ETM-enabled egress interface. This is why low-rate shaper benefits do not accrue to ingress traffic from a remote line card.

- **How do I verify the low shaper rate action?**—Run the **show qos interface** command to see the low shaper statistics. For example:

```
router#show qos interface GigabitEthernet 0/2/0/0 output
Level2 Class = exp1
New traffic class = 1
Egressq Queue ID = 1793 (LP queue)
Queue Max. BW. = 3051 kbps (3 mbits/sec)
Queue Min. BW. = 0 kbps (default)
Inverse Weight / Weight = 1 / (BWR not configured)
Guaranteed service rate = 625 kbps
Peak burst = 32832 bytes (default)
TailDrop Threshold = 1280 bytes / 16 ms (default)

LOW SHAPER = Enabled

WRED not configured for this class

Level2 Class = exp2
New traffic class = 2
Egressq Queue ID = 1794 (LP queue)
Queue Max. BW. = 5004 kbps (5 mbits/sec)
Queue Min. BW. = 0 kbps (default)
Inverse Weight / Weight = 1 / (BWR not configured)
Guaranteed service rate = 625 kbps
Peak burst = 32832 bytes (default)
TailDrop Threshold = 1280 bytes / 16 ms (default)

LOW SHAPER = Enabled

WRED not configured for this class
```

Low Rate Shaper for Enhanced Granularity

Table 53: Feature History Table

Feature Name	Release Information	Feature Description
Low Rate Shaper for Enhanced Granularity	Release 24.3.1	<p>Introduced in this release on: NCS 5700 line cards [Mode: Native]</p> <p>In local Virtual Output Queue (VOQ) switching, you can now achieve precise parent shaper granularity on ETM-enabled interfaces by configuring shared shaper elements in a quad shaper to 0 kbps.</p> <p>This is made possible by enabling a virtual flow using a low-rate connector to the highest-priority queue in the egress pipeline, maintaining the granularity for the four levels of priority and preventing traffic congestion.</p> <p>The feature introduces these changes:</p> <p>CLI:</p> <ul style="list-style-type: none"> hw-module profile qos etm-low-rate-connector npu-id npu-id reserve-conn-range range hw-module profile qos etm-low-rate-connector npu-id npu-id reserve-conn-range range location node-location <p>YANG Data Models:</p> <ul style="list-style-type: none"> New Xpaths for <code>Cisco-IOS-XR-um-hw-module-profile-cfg.yang</code> <p>(see GitHub, YANG Data Models Navigator)</p>

Priority Scheduling and Shaping Accuracy on ETM-enabled Interfaces

The enhanced low rate shaper granularity for ETM-enabled interfaces feature significantly improves egress traffic management by ensuring precise parent shaper granularity. This feature also enables

- configuration of 0 kbps shaping rate for shared shaper elements in a quad shaper using virtual flows, and
- four-level priority support preventing unnecessary congestion or slow traffic.

In the Egress Traffic Management (ETM) model, the local VOQ switching hierarchy uses a shared shaper to manage traffic. This shared shaper aggregates four scheduling elements (FQ1, FQ2, FQ3, and CL) into a single shaping unit to achieve four-level priority support. The priority flow of these elements is FQ1 > FQ2 > FQ3 > CL, supporting four levels of bandwidth priority configuration.

Prior to Cisco IOS XR release 24.3.1, the forwarding ASIC in the NCS 5700 line cards was capable of supporting only 3.9 Mbps as the lowest configurable bandwidth for a particular traffic class on all four shaper elements (FQ1, FQ2, FQ3, and CL). This limitation resulted in an additional 11.7 Mbps (3 x 3.9 Mbps) of unexpected bandwidth from the shared shaper elements causing inaccuracies in the parent shaper's traffic management. However, the enhanced low-rate shaper feature enables

By eliminating the additional 11.7 Mbps of unexpected bandwidth, the feature ensures that the parent shaper granularity is more accurate. This enhancement allows for better management of the four levels of priority, ensuring that each level operates as intended without interference from the shared shaper elements.

How Virtual Flows Enhance Shaper Granularity?

This feature achieves such low-rate shaping accuracy by introducing support for a configurable virtual flow, which is a low-rate connector to the highest-priority queue (FQ1) in the egress pipeline. This virtual flow is connected to the relevant high-priority queue and keeps it active to receive bandwidth credits even though there is no subscriber traffic. The credit tokens are priority propagated to other elements with 0 Kbps shapers.

Usage Guidelines for Low-rate Shaper Granularity Enhancements

- Supported Cisco NCS 5700 line cards must operate in the native mode only.
- By default, 2048 low-rate connectors are available. However, you can configure to reserve the low-rate connectors per NPU core based on specific QoS scale requirements.
- A virtual flow is configured using the low-rate connector allocated to a shared quad shaper if the shaper value of the parent policy applied on an ETM-enabled interface is less than 500 Mbps.
- Router must have an external TCAM.
- Hierarchical QoS (H-QoS) mode must be disabled.

Configure a Virtual Flow using Low-rate Connectors

To enable virtual flows, configure to reserve system allocated low-rate connectors for achieving precise shaper granularity at 0 kbps for shared shaper elements on the ETM-enabled interfaces.



Note To enable this feature, you must configure the shaper value of the parent policy to be less than 500 Mbps.

Before you begin

Before you configure virtual flows, verify

- the NCS 5700 line card is operating in the native mode, and

- the interface is configured in the ETM mode.

Procedure

Step 1 Configure a low-rate shaping QoS policy.

Example:

```
Router(config)#policy-map egr
Router(config-pmap)#class qos-1
Router(config-pmap-c)#shape average 450 mbps
Router(config-pmap-c)#exit
Router(config-pmap)#end-policy-map
Router(config)#commit
```

Step 2 Attach the QoS policy to an interface.

Example:

```
Router(config)#interface HundredGigE 0/6/0/18
Router(config-int)#service-policy output egr
Router(config-int)#commit
```

Step 3 Configure to reserve low-rate connectors:

- For all line cards in a modular router, use the **hw-module profile qos etm-low-rate-connector npu-id *npu-id* reserve-conn-range** command.

Example:

```
Router(config)#hw-module profile qos etm-low-rate-connector npu-id 0 reserve-conn-range 4
Router(config)#commit
```

- For a specific line card or node in a modular router, use the **hw-module profile qos etm-low-rate-connector npu-id *npu-id* reserve-conn-rangelocationnode-location** command.

Example:

```
Router(config)#hw-module profile qos etm-low-rate-connector npu-id 0 reserve-conn-range 1 location
0/1/CPU0
Router(config)#commit
```

Step 4 Verify the virtual flow is configured and active.

Example:

```
Router#show qos int hu0/0/0/25 output
Fri May 31 16:03:46.130 UTC
NOTE:- Configured values are displayed within parentheses
Interface HundredGigE0/0/0/25 ifh 0x228 -- output policy
NPU Id: 0
Total number of classes: 6
Interface Bandwidth: 100000000 kbps
Policy Name: egr
SPI Id: 0x0
VOQ Base: 2048
PFC enabled: 0
Accounting Type: Layer1 (Include Layer 1 encapsulation and above)
-----
Level1 Class = qos-1
Queue Max. BW. = 453125 kbps (450 mbits/sec)
```

```
Queue Min. BW.                = 453125 kbps (default)
Inverse Weight / Weight       = 1 / (BWR not configured)
Virtual Flow ID              = 98304

Level2 Class (HP2)           = ETC2
New traffic class             = 2
Egressq Queue ID             = 2050 (HP2 queue)
Queue Max. BW.               = no max (default)
Peak burst                   = 36864 bytes (default)
TailDrop Threshold           = 562432 bytes / 10 ms (default)
```

The virtual flow ID is system-generated and specifies that a virtual flow is configured and active for an NPU core using a low-rate connector.
