



Configuring Ethernet OAM

This module describes the configuration of Ethernet Operations, Administration, and Maintenance (OAM) .

Feature History for Configuring Ethernet OAM

Release	Modification
Release 6.1.1	Support for the following features was introduced: <ul style="list-style-type: none">• Ethernet Link OAM• Ethernet CFM
Release 7.1.1	Support for CFM adaptive bandwidth notifications was introduced for NCS5500 platforms.
Release 7.5.1	Support for Link Loss Forwarding (LLF) was introduced.
Release 7.5.1	Support for CFM adaptive bandwidth notifications was introduced for Cisco Network Convergence System 5700 Series routers and routers with Cisco NC57 line cards operating in native mode.

- [Information About Configuring Ethernet OAM, on page 1](#)
- [How to Configure Ethernet OAM, on page 18](#)
- [CFM Over Bundles, on page 46](#)
- [Unidirectional Link Detection Protocol, on page 47](#)
- [Y.1731 Performance Monitoring, on page 51](#)
- [Ethernet SLA Statistics Measurement in a Profile, on page 64](#)
- [Bit Error Rate, on page 68](#)
- [Configuration Examples for Ethernet OAM, on page 71](#)
- [CFM Adaptive Bandwidth Notifications, on page 85](#)
- [Link Loss Forwarding, on page 93](#)
- [CFM and Y 1731 on VPLS over BGP Signaling, on page 95](#)

Information About Configuring Ethernet OAM

To configure Ethernet OAM, you should understand the following concepts:

Ethernet Link OAM

Ethernet as a Metro Area Network (MAN) or a Wide Area Network (WAN) technology benefits greatly from the implementation of Operations, Administration and Maintenance (OAM) features. Ethernet link OAM features allow Service Providers to monitor the quality of the connections on a MAN or WAN. Service providers can monitor specific events, . Ethernet link OAM operates on a single, physical link and it can be configured to monitor either side or both sides of that link.

Ethernet link OAM can be configured in the following ways:

- A Link OAM profile can be configured, and this profile can be used to set the parameters for multiple interfaces.
- Link OAM can be configured directly on an interface.

When an interface is also using a link OAM profile, specific parameters that are set in the profile can be overridden by configuring a different value directly on the interface.

An Ethernet Link OAM profile simplifies the process of configuring EOAM features on multiple interfaces. An Ethernet OAM profile, and all of its features, can be referenced by other interfaces, allowing other interfaces to inherit the features of that Ethernet OAM profile.

Individual Ethernet link OAM features can be configured on individual interfaces without being part of a profile. In these cases, the individually configured features always override the features in the profile.

The preferred method of configuring custom EOAM settings is to create an EOAM profile in Ethernet configuration mode and then attach it to an individual interface or to multiple interfaces.

When an EOAM packet is received on any one of the AC interfaces on which EOAM is not configured, the AC interface multicasts the received EOAM packets to other AC interfaces that are part of EVPN-BD to reach the peer. When an EOAM is enabled on the bundle member in the peer, it punts the packet to the CPU in the peer. Also, the EOAM flaps the bundle member as the local or remote Key of the received EOAM does not match.

These standard Ethernet Link OAM features are supported on the router:

Neighbor Discovery

Neighbor discovery enables each end of a link to learn the OAM capabilities of the other end and establish an OAM peer relationship. Each end also can require that the peer have certain capabilities before it will establish a session. You can configure certain actions to be taken if there is a capabilities conflict or if a discovery process times out, using the **action capabilities-conflict** or **action discovery-timeout** commands.

EFD

Ethernet Fault Detection (EFD) is a mechanism that allows Ethernet OAM protocols, such as CFM, to control the `line protocol` state of an interface.

Unlike many other interface types, Ethernet interfaces do not have a line protocol, whose state is independent from that of the interface. For Ethernet interfaces, this role is handled by the physical-layer Ethernet protocol itself, and therefore if the interface is physically up, then it is available and traffic can flow.

EFD changes this to allow CFM to act as the line protocol for Ethernet interfaces. This allows CFM to control the interface state so that if a CFM defect (such as AIS or loss of continuity) is detected with an expected peer MEP, the interface can be shut down. This not only stops traffic flow, but also triggers actions in any higher-level protocols to route around the problem. For example, in the case of Layer 2 interfaces, the MAC

table would be cleared and MSTP would reconverge. For Layer 3 interfaces, the ARP cache would be cleared and potentially the IGP would reconverge.



Note EFD can only be used for down MEPs. When EFD is used to shut down the interface, the CFM frames continue to flow. This allows CFM to detect when the problem has been resolved, and thus bring the interface backup automatically.

This figure shows CFM detection of an error on one of its sessions EFD signaling an error to the corresponding MAC layer for the interface. This triggers the MAC to go to a down state, which further triggers all higher level protocols (Layer 2 pseudowires, IP protocols, and so on) to go down and also trigger a reconvergence where possible. As soon as CFM detects there is no longer any error, it can signal to EFD and all protocols will once again go active.

Figure 1: CFM Error Detection and EFD Trigger

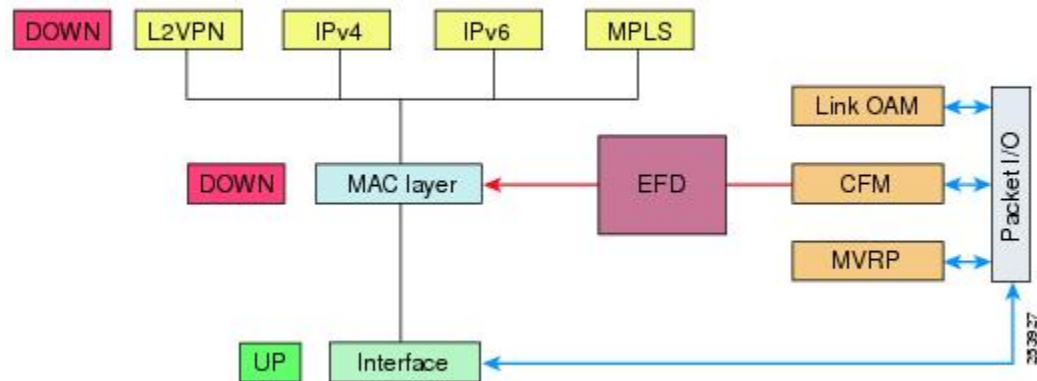

MIB Retrieval

MIB retrieval enables an OAM peer on one side of an interface to get the MIB variables from the remote side of the link. The MIB variables that are retrieved from the remote OAM peer are READ ONLY.

Miswiring Detection (Cisco-Proprietary)

Miswiring Detection is a Cisco-proprietary feature that uses the 32-bit vendor field in every Information OAMPDU to identify potential miswiring cases.

SNMP Traps

SNMP traps can be enabled or disabled on an Ethernet OAM interface.

Ethernet CFM

Table 1: Feature History Table

Feature Name	Release	Description
Cisco NC57 Native Mode: CFM	Release 7.3.1	<p>This feature is now supported on routers that have the Cisco NC57 line cards installed and operate in the native mode.</p> <p>To enable the native mode, use the hw-module profile npu native-mode-enable command in the configuration mode. Ensure that you reload the router after configuring the native mode.</p>

Table 2: Feature History Table

Feature Name	Release	Description
Cisco NC57 Compatibility Mode: CFM	Release 7.4.1	This feature is now supported on routers that have the Cisco NC57 line cards installed and operate in the compatibility mode.

Table 3: Feature History Table

Feature Name	Release	Description
Support for Link Loss Forwarding on Cisco NCS 5500 Series Routers	Release 7.5.1	<p>This feature, now available on Cisco NCS 5500 Series Routers, enables high availability between two bridged interfaces by disabling both interfaces if any one of them fails. This functionality allows a fault detected on one side of a CFM-protected network to propagate to the other side, enabling the device to re-route around the failure at that end. In earlier releases, a failure on one bridged interface did not disable the other interface, and connected devices remained unaware of the link loss.</p>

Ethernet Connectivity Fault Management (CFM) is a service-level OAM protocol that provides tools for monitoring and troubleshooting end-to-end Ethernet services per VLAN. This includes proactive connectivity monitoring, fault verification, and fault isolation. CFM uses standard Ethernet frames and can be run on any

physical media that is capable of transporting Ethernet service frames. Unlike most other Ethernet protocols which are restricted to a single physical link, CFM frames can transmit across the entire end-to-end Ethernet network.



Note Enable a maximum of 32 VLAN ranges per NPU. Else, when you reload the device, all CFM sessions over the 802.1Q VLAN interface might go down. Also, the corresponding bundle interface might go down. If more than 32 VLAN ranges exist on an NPU, remove the additional VLAN ranges and reload the device to address the issue.



Note Up MEP with Cisco NC57 line cards installed and operate in the native and compatibility modes as a part of Layer 2 service. When you have have NC57 line card (compatibility mode) interface as core facing (ingress) and NC57 line card as the AC (egress) interface, the up mep CFM session does not come up.

CFM is defined in two standards:

- IEEE 802.1ag—Defines the core features of the CFM protocol.
- ITU-T Y.1731—Redefines, but maintains compatibility with the features of IEEE 802.1ag, and defines some additional features.

Ethernet CFM supports these functions of ITU-T Y.1731:

- ETH-CC, ETH-RDI, ETH-LB, ETH-LT—These are equivalent to the corresponding features defined in IEEE 802.1ag.



Note The Linktrace responder procedures defined in IEEE 802.1ag are used rather than the procedures defined in Y.1731; however, these are interoperable.

- ETH-AIS—The reception of ETH-LCK messages is also supported.

To understand how the CFM maintenance model works, you need to understand these concepts and features:

Maintenance Domains

A maintenance domain describes a management space for the purpose of managing and administering a network. A domain is owned and operated by a single entity and defined by the set of interfaces internal to it and at its boundary, as shown in this figure.

Figure 2: CFM Maintenance Domain

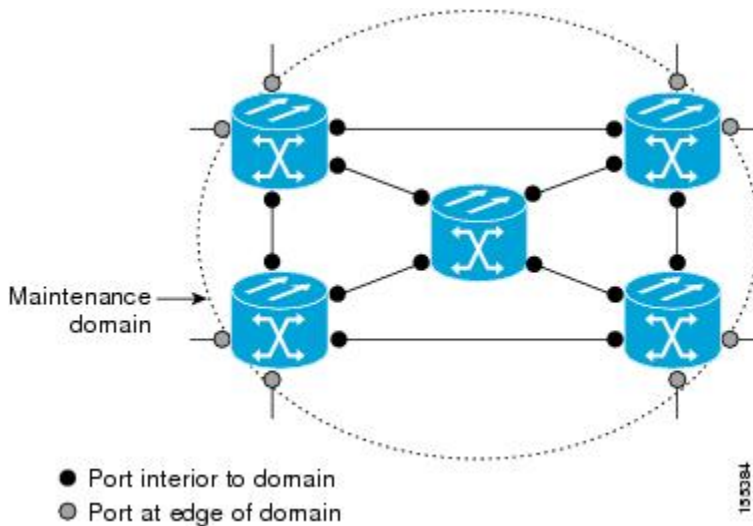

A maintenance domain is defined by the bridge ports that are provisioned within it. Domains are assigned maintenance levels, in the range of 0 to 7, by the administrator. The level of the domain is useful in defining the hierarchical relationships of multiple domains.

CFM maintenance domains allow different organizations to use CFM in the same network, but independently. For example, consider a service provider who offers a service to a customer, and to provide that service, they use two other operators in segments of the network. In this environment, CFM can be used in the following ways:

- The customer can use CFM between their CE devices, to verify and manage connectivity across the whole network.
- The service provider can use CFM between their PE devices, to verify and manage the services they are providing.
- Each operator can use CFM within their operator network, to verify and manage connectivity within their network.

Each organization uses a different CFM maintenance domain.

This figure shows an example of the different levels of maintenance domains in a network.



Note In CFM diagrams, the conventions are that triangles represent MEPs, pointing in the direction that the MEP sends CFM frames, and circles represent MIPs.

Figure 3: Different CFM Maintenance Domains Across a Network

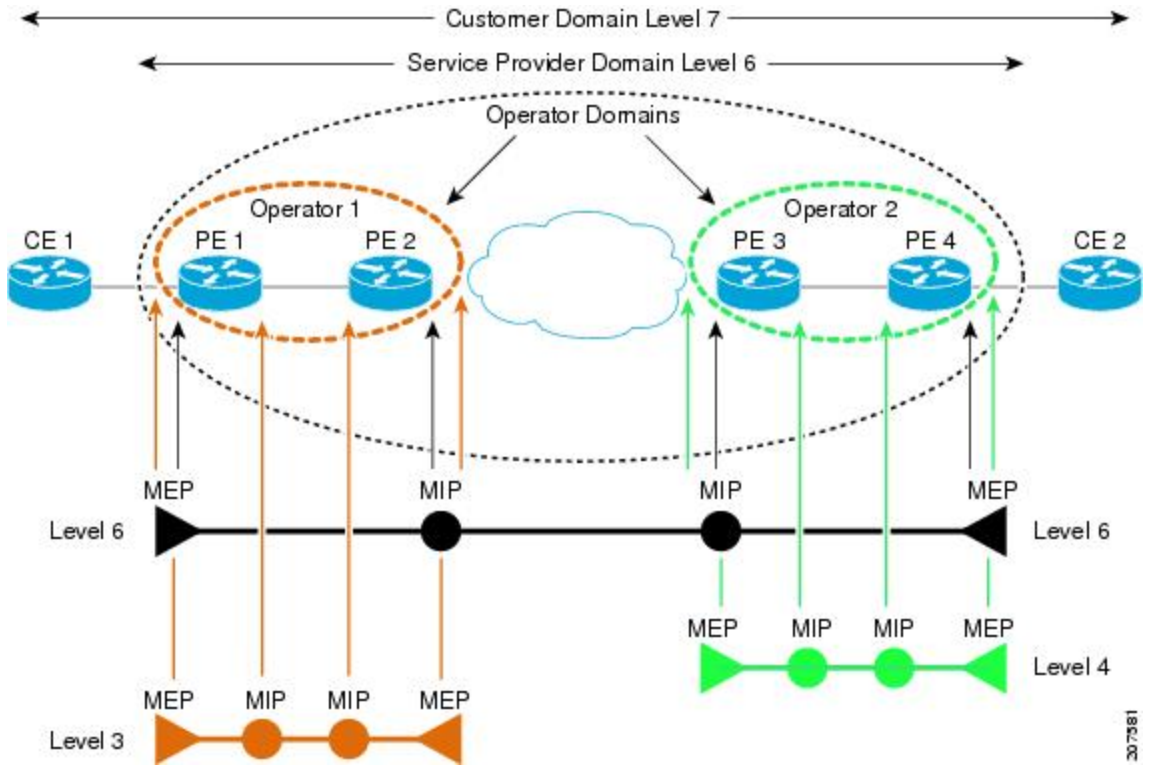

To ensure that the CFM frames for each domain do not interfere with each other, each domain is assigned a maintenance level, between 0 and 7. Where domains are nested, as in this example, the encompassing domain must have a higher level than the domain it encloses. In this case, the domain levels must be negotiated between the organizations involved. The maintenance level is carried in all CFM frames that relate to that domain.

CFM maintenance domains may touch or nest, but cannot intersect. This figure illustrates the supported structure for touching and nested domains, and the unsupported intersection of domains.

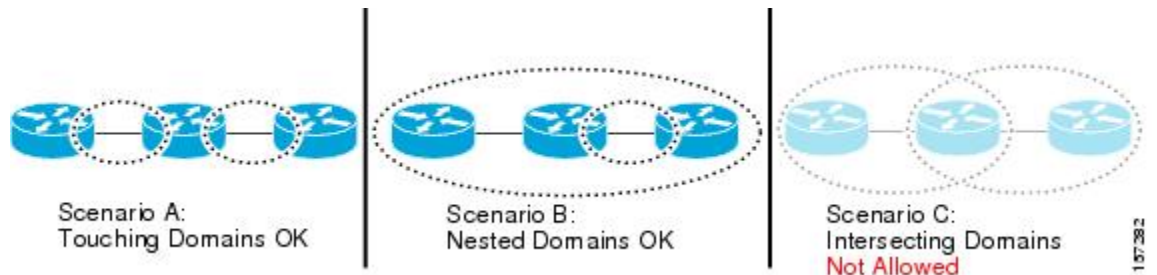

Services

A CFM service allows an organization to partition its CFM maintenance domain, according to the connectivity within the network. For example, if the network is divided into a number of virtual LANs (VLANs), a CFM service is created for each of these. CFM can then operate independently in each service. It is important that the CFM services match the network topology, so that CFM frames relating to one service cannot be received in a different service. For example, a service provider may use a separate CFM service for each of their customers, to verify and manage connectivity between that customer's end points.

A CFM service is always associated with the maintenance domain that it operates within, and therefore with that domain's maintenance level. All CFM frames relating to the service carry the maintenance level of the corresponding domain.



Note CFM Services are referred to as *Maintenance Associations* in IEEE 802.1ag and as *Maintenance Entity Groups* in ITU-T Y.1731.

Maintenance Points

A CFM Maintenance Point (MP) is an instance of a particular CFM service on a specific interface. CFM only operates on an interface if there is a CFM maintenance point on the interface; otherwise, CFM frames are forwarded transparently through the interface.

A maintenance point is always associated with a particular CFM service, and therefore with a particular maintenance domain at a particular level. Maintenance points generally only process CFM frames at the same level as their associated maintenance domain. Frames at a higher maintenance level are always forwarded transparently, while frames at a lower maintenance level are normally dropped. This helps enforce the maintenance domain hierarchy, and ensures that CFM frames for a particular domain cannot leak out beyond the boundary of the domain.

There are two types of MP:

- Maintenance End Points (MEPs)—Created at the edge of the domain. Maintenance end points (MEPs) are members of a particular service within a domain and are responsible for sourcing and sinking CFM frames. They periodically transmit continuity check messages and receive similar messages from other MEPs within their domain. They also transmit traceroute and loopback messages at the request of the administrator. MEPs are responsible for confining CFM messages within the domain.
- Maintenance Intermediate Points (MIPs)—Created in the middle of the domain. Unlike MEPS, MIPs do allow CFM frames at their own level to be forwarded.

MIP Creation

Unlike MEPS, MIPs are not explicitly configured on each interface. MIPs are created automatically according to the algorithm specified in the CFM 802.1ag standard. The algorithm, in brief, operates as follows for each interface:

- The bridge-domain or cross-connect for the interface is found, and all services associated with that bridge-domain or cross-connect are considered for MIP auto-creation.
- The level of the highest-level MEP on the interface is found. From among the services considered above, the service in the domain with the lowest level that is higher than the highest MEP level is selected. If there are no MEPs on the interface, the service in the domain with the lowest level is selected.

- The MIP auto-creation configuration (**mip auto-create** command) for the selected service is examined to determine whether a MIP should be created.



Note Configuring a MIP auto-creation policy for a service does not guarantee that a MIP will automatically be created for that service. The policy is only considered if that service is selected by the algorithm first.

MEP and CFM Processing Overview

The boundary of a domain is an interface, rather than a bridge or host. Therefore, MEPs can be sub-divided into two categories:

- Down MEPs—Send CFM frames from the interface where they are configured, and process CFM frames received on that interface. Down MEPs transmit AIS messages upward (toward the cross-connect).
- Up MEPs—Send frames into the bridge relay function, as if they had been received on the interface where the MEP is configured. They process CFM frames that have been received on other interfaces, and have been switched through the bridge relay function as if they are going to be sent out of the interface where the MEP is configured. Up MEPs transmit AIS messages downward (toward the wire). However, AIS packets are only sent when there is a MIP configured on the same interface as the MEP and at the level of the MIP.



-
- Note**
- The terms *Down MEP* and *Up MEP* are defined in the IEEE 802.1ag and ITU-T Y.1731 standards, and refer to the direction that CFM frames are sent from the MEP. The terms should not be confused with the operational status of the MEP.
 - The router only supports the “Down MEP level < Up MEP level” configuration.
-

This figure illustrates the monitored areas for Down and Up MEPs.

Figure 4: Monitored Areas for Down and Up MEPs

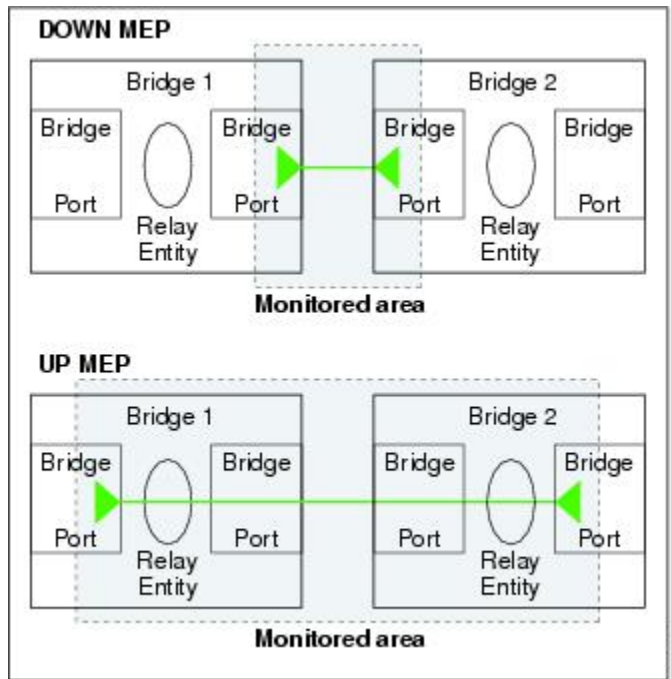

This figure shows maintenance points at different levels. Because domains are allowed to nest but not intersect (see), a MEP at a low level always corresponds with a MEP or MIP at a higher level. In addition, only a single MIP is allowed on any interface—this is generally created in the lowest domain that exists at the interface and that does not have a MEP.

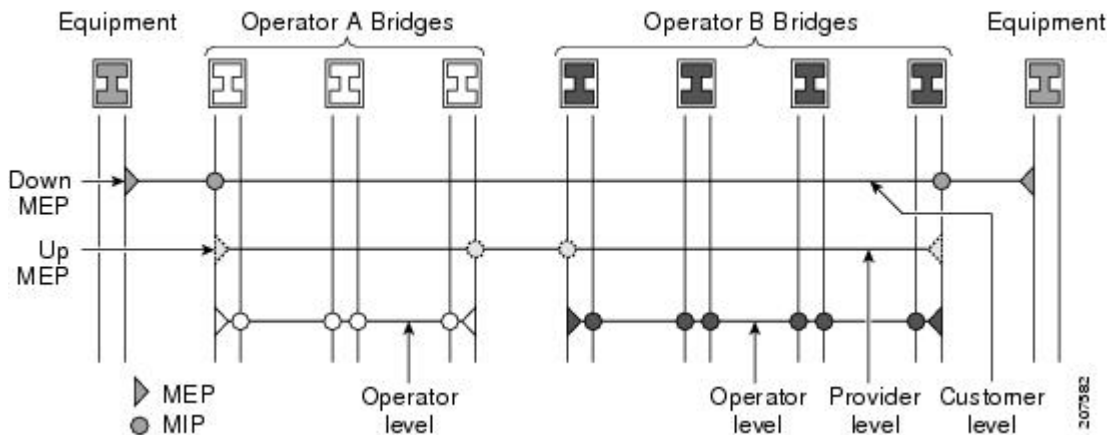

MIPs and Up MEPs can only exist on switched (Layer 2) interfaces, because they send and receive frames from the bridge relay function. Down MEPs can be created on switched (Layer 2) interfaces.

MEPs continue to operate normally if the interface they are created on is blocked by the Spanning Tree Protocol (STP); that is, CFM frames at the level of the MEP continue to be sent and received, according to the direction of the MEP. MEPs never allow CFM frames at the level of the MEP to be forwarded, so the STP block is maintained.

MIPs also continue to receive CFM frames at their level if the interface is STP blocked, and can respond to any received frames. However, MIPs do not allow CFM frames at the level of the MIP to be forwarded if the interface is blocked.



Note A separate set of CFM maintenance levels is created every time a VLAN tag is pushed onto the frame. Therefore, if CFM frames are received on an interface which pushes an additional tag, so as to “tunnel” the frames over part of the network, the CFM frames will not be processed by any MPs within the tunnel, even if they are at the same level. For example, if a CFM MP is created on an interface with an encapsulation that matches a single VLAN tag, any CFM frames that are received at the interface that have two VLAN tags will be forwarded transparently, regardless of the CFM level.

CFM Protocol Messages

The CFM protocol consists of a number of different message types, with different purposes. All CFM messages use the CFM EtherType, and carry the CFM maintenance level for the domain to which they apply.

This section describes the following CFM messages:

Continuity Check (IEEE 802.1ag and ITU-T Y.1731)

Continuity Check Messages (CCMs) are “heartbeat” messages exchanged periodically between all the MEPs in a service. Each MEP sends out multicast CCMs, and receives CCMs from all the other MEPs in the service—these are referred to as *peer MEPs*. This allows each MEP to discover its peer MEPs, and to verify that there is connectivity between them.

MIPs also receive CCMs. MIPs use the information to build a MAC learning database that is used when responding to Linktrace. For more information about Linktrace, see the [Linktrace \(IEEE 802.1ag and ITU-T Y.1731\)](#).

Figure 5: Continuity Check Message Flow

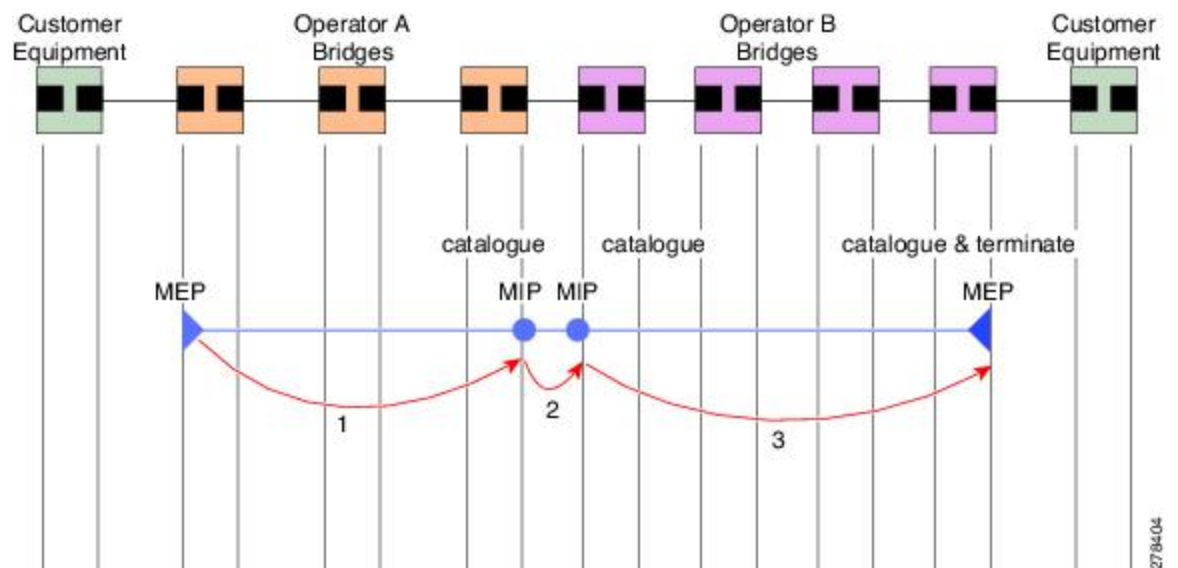

All the MEPs in a service must transmit CCMs at the same interval. IEEE 802.1ag defines 7 possible intervals that can be used:

- 3.3ms
- 10ms
- 100ms
- 1s
- 10s
- 1 minute

A MEP detects a loss of connectivity with one of its peer MEPs when some number of CCMs have been missed. This occurs when sufficient time has passed during which a certain number of CCMs were expected, given the CCM interval. This number is called the *loss threshold*, and is usually set to 3.

CFM is supported only on interfaces which have Layer 2 transport feature enabled.

Maintenance Association Identifier (MAID)

Table 4: Feature History Table

Feature Name	Release	Description
48 byte string-based MAID support for Offloaded Endpoints	Release 7.5.1	<p>This feature is supported on Cisco Network Convergence System 5700 Series routers and routers with the Cisco NC57 line cards operating in native mode. This feature extends MAID functionality to support the flexible format for hardware offloaded MEPs. This removes the restrictions on the type of MAID supported for sessions with less than 1 minute time intervals.</p> <p>To enable the feature in native mode, run the Ethernet CFM Show Command for flexible packet format: Examples command in the System Admin Config mode, and reload the router.</p>

CCM messages carry a variety of information that allows different defects to be detected in the service. This information includes:

- A configured identifier for the domain of the transmitting MEP. This is referred to as the Maintenance Domain Identifier (MDID).
- A configured identifier for the service of the transmitting MEP. This is referred to as the Short MA Name (SMAN). Together, the MDID and the SMAN make up the Maintenance Association Identifier (MAID). The MAID must be configured identically on every MEP in the service.
- These are restrictions on the type of MAID that are supported for sessions with time interval of less than 1 minute. The MAID supports two types of formats on offloaded MEPs:

- No Domain Name Format
 - MD Name Format = 1-NoDomainName
 - Short MA Name Format = 3 - 2 bytes integer value
 - Short MA Name Length = 2 - fixed length
 - Short MA Name = 2 bytes of integer

- 1731 Maid Format
 - MD Name Format = 1-NoDomainName
 - MA Name Format(MEGID Format) = 32
 - MEGID Length = 13 - fixed length
 - MEGID(ICCCode) = 6 Bytes
 - MEGID(UMC) = 7 Bytes
 - ITU Carrier Code (ICC) - Number of different configurable ICC code - 15 (for each NPU)
 - Unique MEG ID Code (UMC) - 4

Maintenance Association Identifier (MAID) comprises of the Maintenance Domain Identifier (MDID) and Short MA Name (SMAN).

MDID **only** supports **null** value and SMAN supports ITU Carrier Code (ICC) or a numerical. No other values are supported.

An example for configuring domain ID null is: **ethernet cfm domain SMB level 3 id null**

An example for configuring SMAN is: **ethernet cfm domain SMB level 3 id null service 901234AB xconnect group 99999 p2p 99999 id number 1**

The following table summarizes the supported values and parameters for MDID and SMAN. This table only details the MAID restriction on the hardware offload feature. There is no MAID restriction for software offload or non-offloaded MEPs.

For Cisco NCS 5500 series routers, "id null" has to be explicitly configured for the domain ID, for hardware offloaded sessions.

Format	MDID	SMAN	Support	Comment
	No	2 byte integer	Yes	Up to 2000 entries
	No	13 bytes ICCCode (6 bytes) and UMC (7 bytes)	Yes	Up to 15 unique ICC Up to 4K UMC values
48 bytes string based	1-48 bytes of MDID and SMAN		No	Most commonly used

- A configured numeric identifier for the MEP (the MEP ID). Each MEP in the service must be configured with a different MEP ID.

- Dynamic Remote MEPs are not supported for MEPs with less than 1min interval. You must configure MEP CrossCheck for all such MEPS.
- Sequence numbering is not supported for MEPs with less than 1 minute interval.
- Starting from Cisco IOS XR SoftwareRelease 7.5.1, MAID supports the flexible packet format of MEG IDs on hardware offloaded MEPs for the following Cisco NC57 line cards:
 - NC57-24DD
 - NCS-57C3-MODS-SYS

This feature is supported only on Cisco NC57 line cards installed and operate in native mode. It removes the restrictions on the type of MAID that are supported for sessions with less than 1 minute time intervals. This helps in interop with the devices which already support the flexible format configuration.

An example of configuring domain ID is **ethernet cfm domain SMB level 3 id string** or **ethernet cfm domain SMB level 3**

An example for configuring SMAN is **ethernet cfm domain SMB level 3 id null service 901234AB xconnect group 99999 p2p 99999 id string** or **ethernet cfm domain SMB level 3 id null service 901234AB xconnect group 99999 p2p 99999**

- In a Remote Defect Indication (RDI), each MEP includes this in the CCMs it is sending, if it has detected a defect relating to the CCMs it is receiving. This notifies all the MEPs in the service that a defect has been detected somewhere in the service.
- The interval at which CCMs are being transmitted.
- CCM Tx/Rx statistics counters are not supported for MEPs with less than 1 minute intervals.
- Sender TLV and Cisco Proprietary TLVs are not supported for MEPs with less than 1min intervals.
- The status of the interface where the MEP is operating—for example, whether the interface is up, down, STP blocked, and so on.



Note The status of the interface (up/down) should not be confused with the direction of any MEPs on the interface (Up MEPs/Down MEPs).

These defects can be detected from received CCMs:

- Interval mismatch—The CCM interval in the received CCM does not match the interval that the MEP is sending CCMs.
- Level mismatch—A MEP has received a CCM carrying a lower maintenance level than the MEPs own level.
- Loop—A CCM is received with the source MAC address equal to the MAC address of the interface where the MEP is operating.
- Configuration error—A CCM is received with the same MEP ID as the MEP ID configured for the receiving MEP.

- Cross-connect—A CCM is received with an MAID that does not match the locally configured MAID. This generally indicates a VLAN misconfiguration within the network, such that CCMs from one service are leaking into a different service.
- Peer interface down—A CCM is received that indicates the interface on the peer is down.
- Remote defect indication—A CCM is received carrying a remote defect indication.



Note This defect does not cause the MEP to include a remote defect indication in the CCMs that it is sending.

Out-of-sequence CCMs can also be detected by monitoring the sequence number in the received CCMs from each peer MEP. However, this is not considered a CCM defect.

Loopback (IEEE 802.1ag and ITU-T Y.1731)

Loopback Messages (LBM) and Loopback Replies (LBR) are used to verify connectivity between a local MEP and a particular remote MP. At the request of the administrator, a local MEP sends unicast LBMs to the remote MP. On receiving each LBM, the target maintenance point sends an LBR back to the originating MEP. Loopback indicates whether the destination is reachable or not—it does not allow hop-by-hop discovery of the path. It is similar in concept to an ICMP Echo (ping). Since loopback messages are destined for unicast addresses, they are forwarded like normal data traffic, while observing the maintenance levels. At each device that the loopback reaches, if the outgoing interface is known (in the bridge's forwarding database), then the frame is sent out on that interface. If the outgoing interface is not known, then the message is flooded on all interfaces.

This figure shows an example of CFM loopback message flow between a MEP and MIP.

Figure 6: Loopback Messages

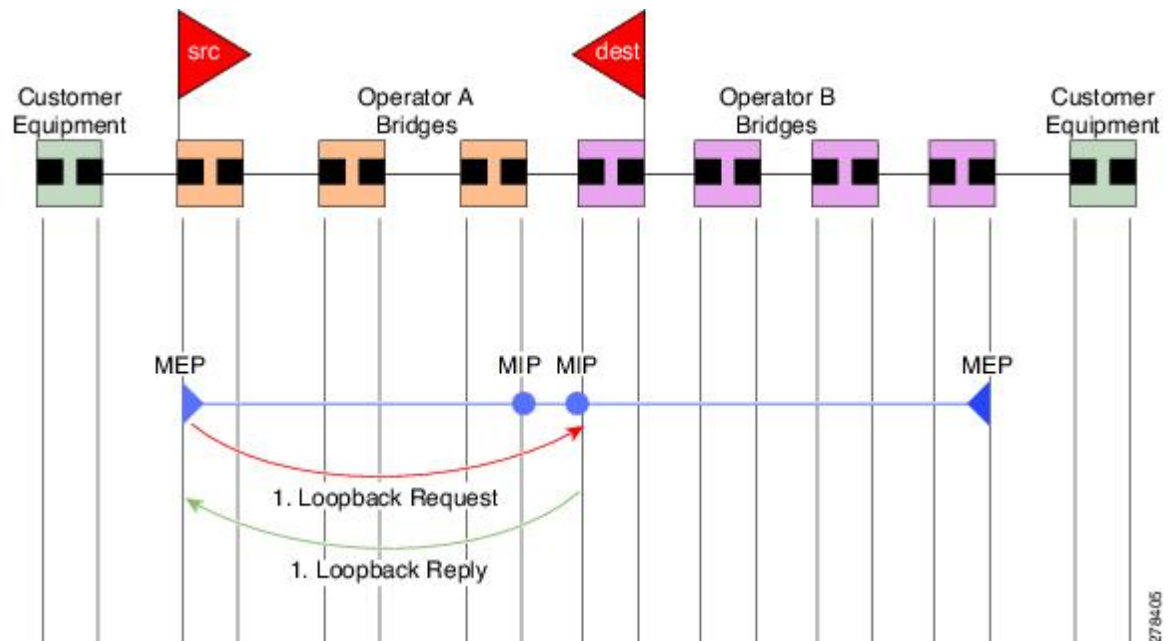

Loopback messages can be padded with user-specified data. This allows data corruption to be detected in the network. They also carry a sequence number which allows for out-of-order frames to be detected.

Linktrace (IEEE 802.1ag and ITU-T Y.1731)

Linktrace Messages (LTM) and Linktrace Replies (LTR) are used to track the path (hop-by-hop) to a unicast destination MAC address. At the request of the operator, a local MEP sends an LTM. Each hop where there is a maintenance point sends an LTR back to the originating MEP. This allows the administrator to discover connectivity data about the path. It is similar in concept to IP traceroute, although the mechanism is different. In IP traceroute, successive probes are sent, whereas CFM Linktrace uses a single LTM which is forwarded by each MP in the path. LTMs are multicast, and carry the unicast target MAC address as data within the frame. They are intercepted at each hop where there is a maintenance point, and either retransmitted or dropped to discover the unicast path to the target MAC address.

This figure shows an example of CFM linktrace message flow between MEPs and MIPs.

Figure 7: Linktrace Message Flow

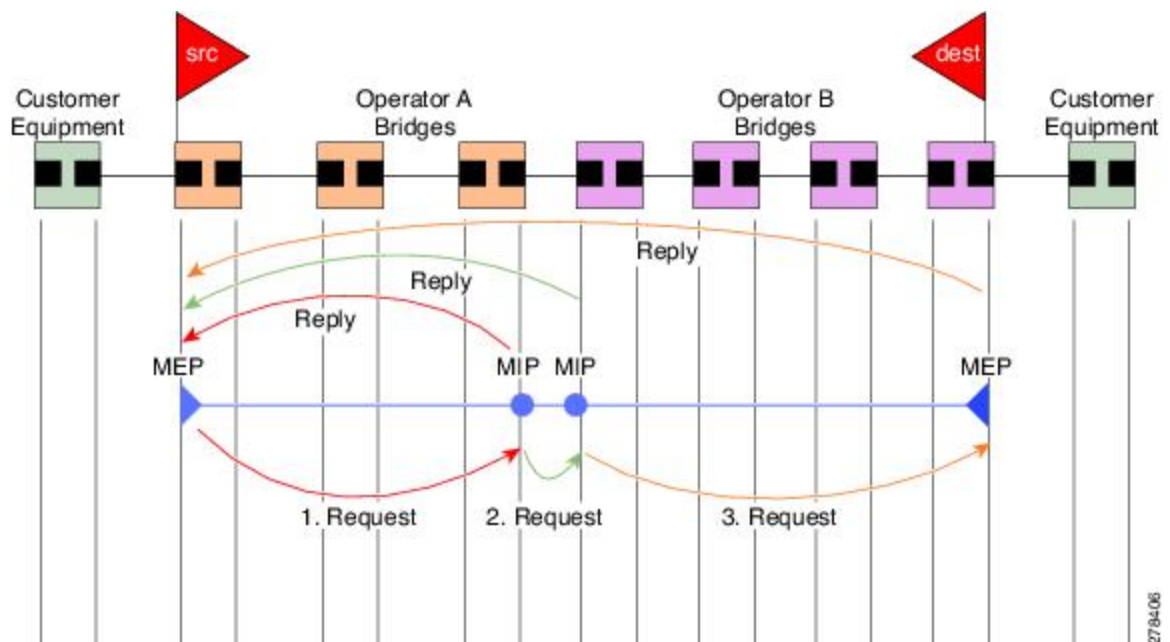

The linktrace mechanism is designed to provide useful information even after a network failure. This allows it to be used to locate failures, for example after a loss of continuity is detected. To achieve this, each MP maintains a CCM Learning Database. This maps the source MAC address for each received CCM to the interface through which the CCM was received. It is similar to a typical bridge MAC learning database, except that it is based only on CCMs and it times out much more slowly—on the order of days rather than minutes.



Note In IEEE 802.1ag, the CCM Learning Database is referred to as the MIP CCM Database. However, it applies to both MIPs and MEPs.

In IEEE 802.1ag, when an MP receives an LTM message, it determines whether to send a reply using the following steps:

1. The target MAC address in the LTM is looked up in the bridge MAC learning table. If the MAC address is known, and therefore the egress interface is known, then an LTR is sent.
2. If the MAC address is not found in the bridge MAC learning table, then it is looked up in the CCM learning database. If it is found, then an LTR is sent.
3. If the MAC address is not found, then no LTR is sent (and the LTM is not forwarded).

If the target MAC has never been seen previously in the network, the linktrace operation will not produce any results.



Note IEEE 802.1ag and ITU-T Y.1731 define slightly different linktrace mechanisms. In particular, the use of the CCM learning database and the algorithm described above for responding to LTM messages are specific to IEEE 802.1ag. IEEE 802.1ag also specifies additional information that can be included in LTRs. Regardless of the differences, the two mechanisms are interoperable.

Configurable Logging

CFM supports logging of various conditions to syslog. Logging can be enabled independently for each service, and when the following conditions occur:

- New peer MEPs are detected, or loss of continuity with a peer MEP occurs.
- Changes to the CCM defect conditions are detected.
- Cross-check “missing” or “unexpected” conditions are detected.
- AIS condition detected (AIS messages received) or cleared (AIS messages no longer received).
- EFD used to shut down an interface, or bring it back up.

Flexible VLAN Tagging for CFM

The Flexible VLAN Tagging for CFM feature ensures that CFM packets are sent with the right VLAN tags so that they are appropriately handled as a CFM packet by the remote device. When packets are received by an edge router, they are treated as either CFM packets or data packets, depending on the number of tags in the header. The system differentiates between CFM packets and data packets based on the number of tags in the packet, and forwards the packets to the appropriate paths based on the number of tags in the packet.

CFM frames are normally sent with the same VLAN tags as the corresponding customer data traffic on the interface, as defined by the configured encapsulation and tag rewrite operations. Likewise, received frames are treated as CFM frames if they have the correct number of tags as defined by the configured encapsulation and tag rewrite configuration, and are treated as data frames (that is, they are forwarded transparently) if they have more than this number of tags.

In most cases, this behavior is as desired, since the CFM frames are then treated in exactly the same way as the data traffic flowing through the same service. However, in a scenario where multiple customer VLANs are multiplexed over a single multipoint provider service (for example, N:1 bundling), a different behavior might be desirable.

This figure shows an example of a network with multiple VLANS using CFM.

Figure 8: Service Provider Network With Multiple VLANs and CFM

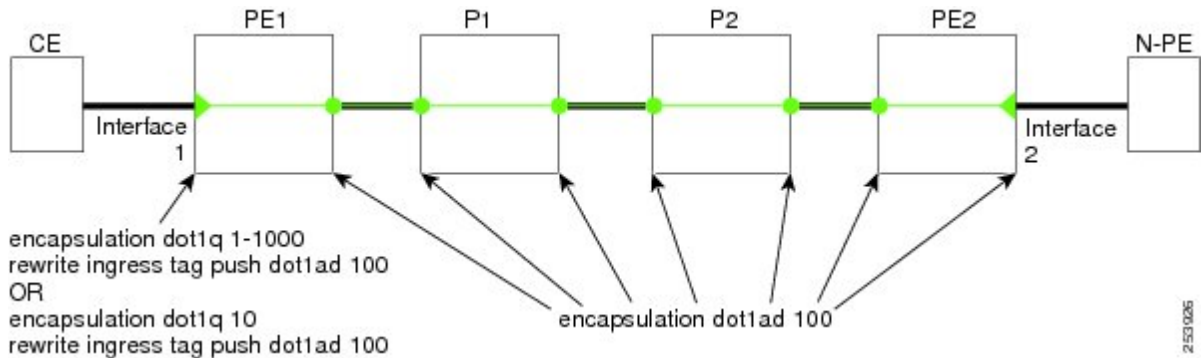

This figure shows a provider's access network, where the S-VLAN tag is used as the service delimiter. PE1 faces the customer, and PE2 is at the edge of the access network facing the core. N:1 bundling is used, so the interface encapsulation matches a range of C-VLAN tags. This could potentially be the full range, resulting in all:1 bundling. There is also a use case where only a single C-VLAN is matched, but the S-VLAN is nevertheless used as the service delimiter—this is more in keeping with the IEEE model, but limits the provider to 4094 services.

CFM is used in this network with a MEP at each end of the access network, and MIPs on the boxes within the network (if it is native Ethernet). In the normal case, CFM frames are sent by the up MEP on PE1 with two VLAN tags, matching the customer data traffic. This means that at the core interfaces and at the MEP on PE2, the CFM frames are forwarded as if they were customer data traffic, since these interfaces match only on the S-VLAN tag. So, the CFM frames sent by the MEP on PE1 are not seen by any of the other MIPs.

Flexible VLAN tagging changes the encapsulation for CFM frames that are sent and received at Up MEPs. Flexible VLAN tagging allows the frames to be sent from the MEP on PE1 with just the S-VLAN tag that represents the provider service. If this is done, the core interfaces will treat the frames as CFM frames and they will be seen by the MIPs and by the MEP on PE2. Likewise, the MEP on PE1 should handle received frames with only one tag, as this is what it will receive from the MEP on PE2.

To ensure that CFM packets from Up MEPs are routed to the appropriate paths successfully, tags may be set to a specific number in a domain service, using the **tags** command. Currently, tags can only be set to one (1).

How to Configure Ethernet OAM

This section provides these configuration procedures:

Configuring Ethernet Link OAM

Custom EOAM settings can be configured and shared on multiple interfaces by creating an EOAM profile in Ethernet configuration mode and then attaching the profile to individual interfaces. The profile configuration does not take effect until the profile is attached to an interface. After an EOAM profile is attached to an interface, individual EOAM features can be configured separately on the interface to override the profile settings when desired.

This section describes how to configure an EOAM profile and attach it to an interface in these procedures:

Configuring an Ethernet OAM Profile

Perform these steps to configure an Ethernet OAM profile.

SUMMARY STEPS

1. **configure**
2. **ethernet oam profile** *profile-name*
3. **link-monitor**
4. **symbol-period window** *window*
5. **symbol-period threshold low** *threshold* **high** *threshold*
6. **frame window** *window*
7. **frame threshold low** *threshold* **high** *threshold*
8. **frame-period window** *window*
9. **frame-period threshold low***threshold* **high** *threshold*
10. **frame-seconds window** *window*
11. **frame-seconds threshold low** *threshold* **high** *threshold*
12. **exit**
13. **mib-retrieval**
14. **connection timeout** *<timeout>*
15. **hello-interval** {100ms|1s}
16. **mode** {active|passive}
17. **require-remote mode** {active|passive}
18. **require-remote mib-retrieval**
19. **action capabilities-conflict** {disable | efd | error-disable-interface}
20. **action critical-event** {disable | error-disable-interface}
21. **action discovery-timeout** {disable | efd | error-disable-interface}
22. **action dying-gasp** {disable | error-disable-interface}
23. **action high-threshold** {error-disable-interface | log}
24. **action session-down** {disable | efd | error-disable-interface}
25. **action session-up** disable
26. **action uni-directional link-fault** {disable | efd | error-disable-interface}
27. **action wiring-conflict** {disable | efd | log}
28. **uni-directional link-fault detection**
29. **commit**
30. **end**

DETAILED STEPS

	Command or Action	Purpose
Step 1	configure Example: RP/0/RP0/CPU0:router# configure terminal	Enters global configuration mode.

	Command or Action	Purpose
Step 2	ethernet oam profile <i>profile-name</i> Example: <pre>RP/0/RP0/CPU0:router(config)# ethernet oam profile Profile_1</pre>	Creates a new Ethernet Operations, Administration and Maintenance (OAM) profile and enters Ethernet OAM configuration mode.
Step 3	link-monitor Example: <pre>RP/0/RP0/CPU0:router(config-eoam)# link-monitor</pre>	Enters the Ethernet OAM link monitor configuration mode.
Step 4	symbol-period window <i>window</i> Example: <pre>RP/0/RP0/CPU0:router(config-eoam-lm)# symbol-period window 60000</pre>	(Optional) Configures the window size (in milliseconds) for an Ethernet OAM symbol-period error event. The IEEE 802.3 standard defines the window size as a number of symbols rather than a time duration. These two formats can be converted either way by using a knowledge of the interface speed and encoding. The range is 1000 to 60000. The default value is 1000.
Step 5	symbol-period threshold low <i>threshold</i> high <i>threshold</i> Example: <pre>RP/0/RP0/CPU0:router(config-eoam-lm)# symbol-period threshold ppm low 1 high 1000000</pre>	(Optional) Configures the thresholds (in symbols) that trigger an Ethernet OAM symbol-period error event. The high threshold is optional and is configurable only in conjunction with the low threshold. The range is 0 to 60000000. The default low threshold is 1.
Step 6	frame window <i>window</i> Example: <pre>RP/0/RP0/CPU0:router(config-eoam-lm)# frame window 6000</pre>	(Optional) Configures the frame window size (in milliseconds) of an OAM frame error event. The range is from 1000 to 60000. The default value is 1000.
Step 7	frame threshold low <i>threshold</i> high <i>threshold</i> Example: <pre>RP/0/RP0/CPU0:router(config-eoam-lm)# frame threshold low 10000000 high 60000000</pre>	(Optional) Configures the thresholds (in symbols) that triggers an Ethernet OAM frame error event. The high threshold is optional and is configurable only in conjunction with the low threshold. The range is from 0 to 60000000. The default low threshold is 1.
Step 8	frame-period window <i>window</i> Example: <pre>RP/0/RP0/CPU0:router(config-eoam-lm)# frame-period window 60000</pre>	(Optional) Configures the window size (in milliseconds) for an Ethernet OAM frame-period error event. The IEEE 802.3 standard defines the window size as number of frames rather than a time duration. These two formats can be converted either way by using a knowledge of the interface speed. Note that the conversion assumes that all frames are of the minimum size.

	Command or Action	Purpose
	<pre>RP/0/RP0/CPU0:router(config-eoam-lm)# frame-period window milliseconds 60000</pre>	<p>The range is from 1000 to 60000.</p> <p>The default value is 1000.</p> <p>Note The only accepted values are multiples of the line cardinterface module-specific polling interval, that is, 1000 milliseconds for most line cardsinterface modules.</p>
Step 9	<p>frame-period threshold low<i>threshold</i> high <i>threshold</i></p> <p>Example:</p> <pre>RP/0/RP0/CPU0:router(config-eoam-lm)# frame-period threshold ppm low 100 high 1000000</pre>	<p>(Optional) Configures the thresholds (in errors per million frames) that trigger an Ethernet OAM frame-period error event. The frame period window is defined in the IEEE specification as a number of received frames, in our implementation it is x milliseconds. The high threshold is optional and is configurable only in conjunction with the low threshold.</p> <p>The range is from 1 to 1000000.</p> <p>The default low threshold is 1.</p> <p>To obtain the number of frames, the configured time interval is converted to a window size in frames using the interface speed. For example, for a 1Gbps interface, the IEEE defines minimum frame size as 512 bits. So, we get a maximum of approximately 1.5 million frames per second. If the window size is configured to be 8 seconds (8000ms) then this would give us a Window of 12 million frames in the specification's definition of Errored Frame Window.</p> <p>The thresholds for frame-period are measured in errors per million frames. Hence, if you configure a window of 8000ms (that is a window of 12 million frames) and a high threshold of 100, then the threshold would be crossed if there are 1200 errored frames in that period (that is, 100 per million for 12 million).</p>
Step 10	<p>frame-seconds window <i>window</i></p> <p>Example:</p> <pre>RP/0/RP0/CPU0:router(config-eoam-lm)# frame-seconds window 900000</pre>	<p>(Optional) Configures the window size (in milliseconds) for the OAM frame-seconds error event.</p> <p>The range is 10000 to 900000.</p> <p>The default value is 60000.</p> <p>Note The only accepted values are multiples of the line cardinterface module-specific polling interval, that is, 1000 milliseconds for most line cardsinterface modules.</p>
Step 11	<p>frame-seconds threshold low <i>threshold</i> high <i>threshold</i></p> <p>Example:</p>	<p>(Optional) Configures the thresholds (in seconds) that trigger a frame-seconds error event. The high threshold value can be configured only in conjunction with the low threshold value.</p>

	Command or Action	Purpose
	RP/0/RP0/CPU0:router(config-eoam-lm)# frame-seconds threshold low 3 high 900	The range is 1 to 900 The default value is 1.
Step 12	exit Example: RP/0/RP0/CPU0:router(config-eoam-lm)# exit	Exits back to Ethernet OAM mode.
Step 13	mib-retrieval Example: RP/0/RP0/CPU0:router(config-eoam)# mib-retrieval	Enables MIB retrieval in an Ethernet OAM profile or on an Ethernet OAM interface.
Step 14	connection timeout <timeout> Example: RP/0/RP0/CPU0:router(config-eoam)# connection timeout 30	Configures the connection timeout period for an Ethernet OAM session, as a multiple of the hello interval. The range is 2 to 30. The default value is 5.
Step 15	hello-interval {100ms 1s} Example: RP/0/RP0/CPU0:router(config-eoam)# hello-interval 100ms	Configures the time interval between hello packets for an Ethernet OAM session. The default is 1 second (1s).
Step 16	mode {active passive} Example: RP/0/RP0/CPU0:router(config-eoam)# mode passive	Configures the Ethernet OAM mode. The default is active.
Step 17	require-remote mode {active passive} Example: RP/0/RP0/CPU0:router(config-eoam)# require-remote mode active	Requires that active mode or passive mode is configured on the remote end before the OAM session becomes active.
Step 18	require-remote mib-retrieval Example: RP/0/RP0/CPU0:router(config-eoam)# require-remote mib-retrieval	Requires that MIB-retrieval is configured on the remote end before the OAM session becomes active.
Step 19	action capabilities-conflict {disable efd error-disable-interface} Example:	Specifies the action that is taken on an interface when a capabilities-conflict event occurs. The default action is to create a syslog entry.

	Command or Action	Purpose
	<pre>RP/0/RP0/CPU0:router(config-eoam)# action capabilities-conflict efd</pre>	<p>Note</p> <ul style="list-style-type: none"> If you change the default, the log keyword option is available in Interface Ethernet OAM configuration mode to override the profile setting and log the event for the interface when it occurs.
Step 20	<p>action critical-event {disable error-disable-interface}</p> <p>Example:</p> <pre>RP/0/RP0/CPU0:router(config-eoam)# action critical-event error-disable-interface</pre>	<p>Specifies the action that is taken on an interface when a critical-event notification is received from the remote Ethernet OAM peer. The default action is to create a syslog entry.</p> <p>Note</p> <ul style="list-style-type: none"> If you change the default, the log keyword option is available in Interface Ethernet OAM configuration mode to override the profile setting and log the event for the interface when it occurs.
Step 21	<p>action discovery-timeout {disable efd error-disable-interface}</p> <p>Example:</p> <pre>RP/0/RP0/CPU0:router(config-eoam)# action discovery-timeout efd</pre>	<p>Specifies the action that is taken on an interface when a connection timeout occurs. The default action is to create a syslog entry.</p> <p>Note</p> <ul style="list-style-type: none"> If you change the default, the log keyword option is available in Interface Ethernet OAM configuration mode to override the profile setting and log the event for the interface when it occurs.
Step 22	<p>action dying-gasp {disable error-disable-interface}</p> <p>Example:</p> <pre>RP/0/RP0/CPU0:router(config-eoam)# action dying-gasp error-disable-interface</pre>	<p>Specifies the action that is taken on an interface when a dying-gasp notification is received from the remote Ethernet OAM peer. The default action is to create a syslog entry.</p> <p>Note</p> <ul style="list-style-type: none"> If you change the default, the log keyword option is available in Interface Ethernet OAM configuration mode to override the profile setting and log the event for the interface when it occurs.
Step 23	<p>action high-threshold {error-disable-interface log}</p> <p>Example:</p> <pre>RP/0/RP0/CPU0:router(config-eoam)# action high-threshold error-disable-interface</pre>	<p>Specifies the action that is taken on an interface when a high threshold is exceeded. The default is to take no action when a high threshold is exceeded.</p> <p>Note</p> <ul style="list-style-type: none"> If you change the default, the disable keyword option is available in Interface Ethernet OAM configuration mode to override the profile setting and take no action at the interface when the event occurs.

	Command or Action	Purpose
Step 24	<p>action session-down {disable efd error-disable-interface}</p> <p>Example:</p> <pre>RP/0/RP0/CPU0:router(config-eoam)# action session-down efd</pre>	<p>Specifies the action that is taken on an interface when an Ethernet OAM session goes down.</p> <p>Note</p> <ul style="list-style-type: none"> If you change the default, the log keyword option is available in Interface Ethernet OAM configuration mode to override the profile setting and log the event for the interface when it occurs.
Step 25	<p>action session-up disable</p> <p>Example:</p> <pre>RP/0/RP0/CPU0:router(config-eoam)# action session-up disable</pre>	<p>Specifies that no action is taken on an interface when an Ethernet OAM session is established. The default action is to create a syslog entry.</p> <p>Note</p> <ul style="list-style-type: none"> If you change the default, the log keyword option is available in Interface Ethernet OAM configuration mode to override the profile setting and log the event for the interface when it occurs.
Step 26	<p>action uni-directional link-fault {disable efd error-disable-interface}</p>	<p>Specifies the action that is taken on an interface when a link-fault notification is received from the remote Ethernet OAM peer. The default action is to create a syslog entry.</p> <p>Note</p> <ul style="list-style-type: none"> If you change the default, the log keyword option is available in Interface Ethernet OAM configuration mode to override the profile setting and log the event for the interface when it occurs.
Step 27	<p>action wiring-conflict {disable efd log}</p> <p>Example:</p> <pre>RP/0/RP0/CPU0:router(config-eoam)# action session-down efd</pre>	<p>Specifies the action that is taken on an interface when a wiring-conflict event occurs. The default is to put the interface into error-disable state.</p> <p>Note</p> <ul style="list-style-type: none"> If you change the default, the error-disable-interface keyword option is available in Interface Ethernet OAM configuration mode to override the profile setting and put the interface into error-disable state when the event occurs.
Step 28	<p>uni-directional link-fault detection</p> <p>Example:</p> <pre>RP/0/RP0/CPU0:router(config-eoam)# uni-directional link-fault detection</pre>	<p>Enables detection of a local, unidirectional link fault and sends notification of that fault to an Ethernet OAM peer.</p>

	Command or Action	Purpose
Step 29	commit Example: RP/0/RP0/CPU0:router(config-if)# commit	Saves the configuration changes to the running configuration file and remains within the configuration session.
Step 30	end Example: RP/0/RP0/CPU0:router(config-if)# end	Ends the configuration session and exits to the EXEC mode.

Attaching an Ethernet OAM Profile to an Interface

Perform these steps to attach an Ethernet OAM profile to an interface:

SUMMARY STEPS

1. **configure**
2. **interface** [FastEthernet | HundredGigE | TenGigE] *interface-path-id*
3. **ethernet oam**
4. **profile** *profile-name*
5. **commit**
6. **end**

DETAILED STEPS

	Command or Action	Purpose
Step 1	configure Example: RP/0/RP0/CPU0:router# configure terminal	Enters global configuration mode.
Step 2	interface [FastEthernet HundredGigE TenGigE] <i>interface-path-id</i> Example: RP/0/RP0/CPU0:router(config)# interface TenGigE 0/1/0/0	Enters interface configuration mode and specifies the Ethernet interface name and notation <i>rack/slot/module/port</i> . Note <ul style="list-style-type: none"> • The example indicates an 8-port 10-Gigabit Ethernet interface in modular services card slot 1.
Step 3	ethernet oam Example: RP/0/RP0/CPU0:router(config-if)# ethernet oam	Enables Ethernet OAM and enters interface Ethernet OAM configuration mode.
Step 4	profile <i>profile-name</i> Example:	Attaches the specified Ethernet OAM profile (<i>profile-name</i>), and all of its configuration, to the interface.

	Command or Action	Purpose
	RP/0/RP0/CPU0:router(config-if-eoam)# profile Profile_1	
Step 5	commit Example: RP/0/RP0/CPU0:router(config-if)# commit	Saves the configuration changes to the running configuration file and remains within the configuration session.
Step 6	end Example: RP/0/RP0/CPU0:router(config-if)# end	Ends the configuration session and exits to the EXEC mode.

Configuring Ethernet OAM at an Interface and Overriding the Profile Configuration

Using an EOAM profile is an efficient way of configuring multiple interfaces with a common EOAM configuration. However, if you want to use a profile but also change the behavior of certain functions for a particular interface, then you can override the profile configuration. To override certain profile settings that are applied to an interface, you can configure that command in interface Ethernet OAM configuration mode to change the behavior for that interface.

In some cases, only certain keyword options are available in interface Ethernet OAM configuration due to the default settings for the command. For example, without any configuration of the **action** commands, several forms of the command have a default behavior of creating a syslog entry when a profile is created and applied to an interface. Therefore, the **log** keyword is not available in Ethernet OAM configuration for these commands in the profile because it is the default behavior. However, the **log** keyword is available in Interface Ethernet OAM configuration if the default is changed in the profile configuration so you can retain the action of creating a syslog entry for a particular interface.

To see all of the default Ethernet OAM configuration settings, see the [Verifying the Ethernet OAM Configuration](#).

To configure Ethernet OAM settings at an interface and override the profile configuration, perform these steps:

SUMMARY STEPS

1. **configure**
2. **interface** [HundredGigE | TenGigE] *interface-path-id*
3. **ethernet oam**
4. *interface-Ethernet-OAM-command*
5. **commit**
6. **end**

DETAILED STEPS

	Command or Action	Purpose
Step 1	configure Example: RP/0/RP0/CPU0:router# configure terminal	Enters global configuration mode.
Step 2	interface [HundredGigE TenGigE] <i>interface-path-id</i> Example: RP/0/RP0/CPU0:router(config)# interface TenGigE 0/1/0/0	Enters interface configuration mode and specifies the Ethernet interface name and notation <i>rack/slot/module/port</i> . Note <ul style="list-style-type: none"> The example indicates an 8-port 10-Gigabit Ethernet interface in modular services card slot 1.
Step 3	ethernet oam Example: RP/0/RP0/CPU0:router(config-if)# ethernet oam	Enables Ethernet OAM and enters interface Ethernet OAM configuration mode.
Step 4	<i>interface-Ethernet-OAM-command</i> Example: RP/0/RP0/CPU0:router(config-if-eoam)# action capabilities-conflict error-disable-interface	Configures a setting for an Ethernet OAM configuration command and overrides the setting for the profile configuration, where <i>interface-Ethernet-OAM-command</i> is one of the supported commands on the platform in interface Ethernet OAM configuration mode.
Step 5	commit Example: RP/0/RP0/CPU0:router(config-if)# commit	Saves the configuration changes to the running configuration file and remains within the configuration session.
Step 6	end Example: RP/0/RP0/CPU0:router(config-if)# end	Ends the configuration session and exits to the EXEC mode.

Verifying the Ethernet OAM Configuration

Use the **show ethernet oam configuration** command to display the values for the Ethernet OAM configuration for a particular interface, or for all interfaces. The following example shows the default values for Ethernet OAM settings:

```
RP/0/RP0/CPU0:router# show ethernet oam configuration
Thu Aug  5 22:07:06.870 DST
GigabitEthernet0/4/0/0:
  Hello interval:                               1s
  Mib retrieval enabled:                         N
  Uni-directional link-fault detection enabled:  N
  Configured mode:                              Active
  Connection timeout:                            5
  Symbol period window:                          0
```

Symbol period low threshold:	1
Symbol period high threshold:	None
Frame window:	1000
Frame low threshold:	1
Frame high threshold:	None
Frame period window:	1000
Frame period low threshold:	1
Frame period high threshold:	None
Frame seconds window:	60000
Frame seconds low threshold:	1
Frame seconds high threshold:	None
High threshold action:	None
Link fault action:	Log
Dying gasp action:	Log
Critical event action:	Log
Discovery timeout action:	Log
Capabilities conflict action:	Log
Wiring conflict action:	Error-Disable
Session up action:	Log
Session down action:	Log
Require remote mode:	Ignore
Require remote MIB retrieval:	N

Configuring Ethernet CFM

To configure Ethernet CFM, perform the following tasks:



Note CFM is not supported for the following:

- L3 Interfaces and Sub-Interfaces
- Bundle Member Ports
- EVPN-FXC
- Bridge Domain
- VPLS

In addition, for NC57 line cards, CFM is also not supported for:

- EVPN
- EVPN-Virtual Private Wire Service (VPWS)

Configuring a CFM Maintenance Domain

To configure a CFM maintenance domain, perform the following steps:

SUMMARY STEPS

1. **configure**
2. **ethernet cfm**
3. **traceroute cache hold-time *minutes* size *entries***

4. **domain** *domain-name* **level** *level-value* [**id** [null] [**dns** *DNS-name*] [**mac** *H.H.H*] [**string** *string*]]
5. **end** or **commit**

DETAILED STEPS

	Command or Action	Purpose
Step 1	<p>configure</p> <p>Example:</p> <pre>RP/0/RP0/CPU0:router# configure</pre>	Enters global configuration mode.
Step 2	<p>ethernet cfm</p> <p>Example:</p> <pre>RP/0/RP0/CPU0:router(config)# ethernet cfm</pre>	Enters Ethernet Connectivity Fault Management (CFM) configuration mode.
Step 3	<p>traceroute cache hold-time <i>minutes</i> size <i>entries</i></p> <p>Example:</p> <pre>RP/0/RP0/CPU0:router(config-cfm)# traceroute cache hold-time 1 size 3000</pre>	(Optional) Sets the maximum limit of traceroute cache entries or the maximum time limit to hold the traceroute cache entries. The default is 100 minutes and 100 entries.
Step 4	<p>domain <i>domain-name</i> level <i>level-value</i> [id [null] [dns <i>DNS-name</i>] [mac <i>H.H.H</i>] [string <i>string</i>]]</p> <p>Example:</p> <pre>RP/0/RP0/CPU0:router(config-cfm)# domain Domain_One level 1 id string D1</pre>	<p>Creates and names a container for all domain configurations and enters CFM domain configuration mode.</p> <p>The level must be specified.</p> <p>The id is the maintenance domain identifier (MDID) and is used as the first part of the maintenance association identifier (MAID) in CFM frames. If the MDID is not specified, the domain name is used as the MDID by default.</p>
Step 5	<p>end or commit</p> <p>Example:</p> <pre>RP/0/RP0/CPU0:router(config-cfm-dmn)# commit</pre>	<p>Saves configuration changes.</p> <ul style="list-style-type: none"> • When you use the end command, the system prompts you to commit changes: <pre>Uncommitted changes found, commit them before exiting(yes/no/cancel)? [cancel]:</pre> • Entering yes saves configuration changes to the running configuration file, exits the configuration session, and returns the router to EXEC mode. • Entering no exits the configuration session and returns the router to EXEC mode without committing the configuration changes. • Entering cancel leaves the router in the current configuration session without exiting or committing the configuration changes.

	Command or Action	Purpose
		<ul style="list-style-type: none"> Use the commit command to save the configuration changes to the running configuration file and remain within the configuration session.

Configuring Services for a CFM Maintenance Domain

You can configure up to 32000 CFM services for a maintenance domain. To configure services for a CFM maintenance domain, perform the following steps:

SUMMARY STEPS

1. **configure**
2. **ethernet cfm**
3. **domain** *domain-name* **level** *level-value* [**id** [null] [**dns** *DNS-name*] [**mac** *H.H.H*] [**string** *string*]]
4. **service** *service-name* {**down-meps** | **xconnect group** *xconnect-group-name* **m2mp** | **p2p** *xconnect-name*} [**id** [**icc-based** *icc-string umc-string*] | [[**number** *number*]]
5. **end** or **commit**

DETAILED STEPS

	Command or Action	Purpose
Step 1	configure Example: RP/0/RP0/CPU0:router# configure	Enters global configuration mode.
Step 2	ethernet cfm Example: RP/0/RP0/CPU0:router(config)# ethernet cfm	Enters Ethernet CFM configuration mode.
Step 3	domain <i>domain-name</i> level <i>level-value</i> [id [null] [dns <i>DNS-name</i>] [mac <i>H.H.H</i>] [string <i>string</i>]] Example: RP/0/RP0/CPU0:router(config-cfm)# domain Domain_One level 1 id string D1	<p>Creates and names a container for all domain configurations at a specified maintenance level, and enters CFM domain configuration mode.</p> <p>The id is the maintenance domain identifier (MDID) and is used as the first part of the maintenance association identifier (MAID) in CFM frames. If the MDID is not specified, the domain name is used as the MDID by default.</p>
Step 4	service <i>service-name</i> { down-meps xconnect group <i>xconnect-group-name</i> m2mp p2p <i>xconnect-name</i> } [id [icc-based <i>icc-string umc-string</i>] [[number <i>number</i>]] Example: RP/0/RP0/CPU0:router(config-cfm-dmn)# service ABC xconnect group X1 p2p ADB	<p>Configures and associates a service with the domain and enters CFM domain service configuration mode. You can specify that the service is used only for down MEPs, or associate the service with a bridge domain where MIPs and up MEPs will be created.</p> <p>The id sets the short MA name.</p>

	Command or Action	Purpose
Step 5	<p>end or commit</p> <p>Example:</p> <pre>RP/0/RP0/CPU0:router(config-cfm-dmn-svc)# commit</pre>	<p>Saves configuration changes.</p> <ul style="list-style-type: none"> When you use the end command, the system prompts you to commit changes: <pre>Uncommitted changes found, commit them before exiting(yes/no/cancel)? [cancel]:</pre> Entering yes saves configuration changes to the running configuration file, exits the configuration session, and returns the router to EXEC mode. Entering no exits the configuration session and returns the router to EXEC mode without committing the configuration changes. Entering cancel leaves the router in the current configuration session without exiting or committing the configuration changes. Use the commit command to save the configuration changes to the running configuration file and remain within the configuration session.

Enabling and Configuring Continuity Check for a CFM Service

To configure Continuity Check for a CFM service, complete the following steps:

SUMMARY STEPS

- configure**
- ethernet cfm**
- domain** *domain-name* **level** *level-value* [**id** [null] [**dns** *DNS-name*] [**mac** *H.H.H*] [**string** *string*]]
- service** *service-name* {**down-meps** | **xconnect group** *xconnect-group-name* **p2p** *xconnect-name*} [**id** [**icc-based** *icc-string umc-string*] | [**number** *number*]
- continuity-check interval** *time* [**loss-threshold** *threshold*]
- continuity-check archive hold-time** *minutes*
- continuity-check loss auto-traceroute**
- end** or **commit**

DETAILED STEPS

	Command or Action	Purpose
Step 1	<p>configure</p> <p>Example:</p> <pre>RP/0/RP0/CPU0:router# configure</pre>	Enters global configuration mode.

	Command or Action	Purpose
Step 2	ethernet cfm Example: <pre>RP/0/RP0/CPU0:router(config)# ethernet cfm</pre>	Enters Ethernet Connectivity Fault Management (CFM) configuration mode.
Step 3	domain <i>domain-name</i> level <i>level-value</i> [id [null]] [dns <i>DNS-name</i>] [mac <i>H.H.H</i>] [string <i>string</i>] Example: <pre>RP/0/RP0/CPU0:router(config-cfm)# domain Domain_One level 1 id string D1</pre>	<p>Creates and names a container for all domain configurations and enters the CFM domain configuration mode.</p> <p>The level must be specified.</p> <p>The id is the maintenance domain identifier (MDID) and is used as the first part of the maintenance association identifier (MAID) in CFM frames. If the MDID is not specified, the domain name is used as the MDID by default.</p>
Step 4	service <i>service-name</i> {down-meps xconnect group <i>xconnect-group-name</i> p2p <i>xconnect-name</i>} [id [icc-based <i>icc-string</i> <i>umc-string</i>] [number <i>number</i>]] Example: <pre>RP/0/RP0/CPU0:router(config-cfm-dmn)# service ABC xconnect group X1 p2p ADB</pre>	<p>Configures and associates a service with the domain and enters CFM domain service configuration mode. You can specify that the service is used only for down MEPs, or associate the service with a bridge domain or xconnect where MIPs and up MEPs will be created.</p> <p>The id sets the short MA name.</p>
Step 5	continuity-check interval <i>time</i> [loss-threshold <i>threshold</i>] Example: <pre>RP/0/RP0/CPU0:router(config-cfm-dmn-svc)# continuity-check interval 100m loss-threshold 10</pre>	(Optional) Enables Continuity Check and specifies the time interval at which CCMs are transmitted or to set the threshold limit for when a MEP is declared down.
Step 6	continuity-check archive hold-time <i>minutes</i> Example: <pre>RP/0/RP0/CPU0:router(config-cfm-dmn-svc)# continuity-check archive hold-time 100</pre>	(Optional) Configures how long information about peer MEPs is stored after they have timed out.
Step 7	continuity-check loss auto-traceroute Example: <pre>RP/0/RP0/CPU0:router(config-cfm-dmn-svc)# continuity-check loss auto-traceroute</pre>	(Optional) Configures automatic triggering of a traceroute when a MEP is declared down.
Step 8	end or commit Example: <pre>RP/0/RP0/CPU0:router(config-cfm-dmn-svc)# commit</pre>	<p>Saves configuration changes.</p> <ul style="list-style-type: none"> When you use the end command, the system prompts you to commit changes: <pre>Uncommitted changes found, commit them before exiting(yes/no/cancel)? [cancel]:</pre>

	Command or Action	Purpose
		<ul style="list-style-type: none"> • Entering yes saves configuration changes to the running configuration file, exits the configuration session, and returns the router to EXEC mode. • Entering no exits the configuration session and returns the router to EXEC mode without committing the configuration changes. • Entering cancel leaves the router in the current configuration session without exiting or committing the configuration changes. • Use the commit command to save the configuration changes to the running configuration file and remain within the configuration session.

Configuring Automatic MIP Creation for a CFM Service

For more information about the algorithm for creating MIPs, see the **MIP Creation** section.

To configure automatic MIP creation for a CFM service, complete the following steps:

SUMMARY STEPS

1. **configure**
2. **ethernet cfm**
3. **domain** *domain-name* **level** *level-value* [**id** **null**] [**dns** *DNS-name*] [**mac** *H.H.H*] [**string** *string*]]
4. **service** *service-name* {**down-meps** | **xconnect group** *xconnect-group-name* **p2p** *xconnect-name*} [**id** [**icc-based** *icc-string umc-string*] | [**number** *number*]
5. **mip auto-create** {**all** | **lower-mep-only**} {**ccm-learning**}
6. **end** or **commit**

DETAILED STEPS

	Command or Action	Purpose
Step 1	configure Example: <pre>RP/0/RP0/CPU0:router# configure</pre>	Enters global configuration mode.
Step 2	ethernet cfm Example: <pre>RP/0/RP0/CPU0:router# ethernet cfm</pre>	Enters the Ethernet Connectivity Fault Management (CFM) configuration mode.
Step 3	domain <i>domain-name</i> level <i>level-value</i> [id null] [dns <i>DNS-name</i>] [mac <i>H.H.H</i>] [string <i>string</i>]] Example:	Creates and names a container for all domain configurations and enters the CFM domain configuration mode.

	Command or Action	Purpose
	<pre>RP/0/RP0/CPU0:router(config-cfm)# domain Domain_One level 1 id string D1</pre>	<p>The level must be specified. The only supported option is id [null] for less than 1min interval MEPS.</p> <p>The id is the maintenance domain identifier (MDID) and is used as the first part of the maintenance association identifier (MAID) in CFM frames. If the MDID is not specified, the domain name is used as the MDID by default.</p>
Step 4	<p>service <i>service-name</i> {down-meps xconnect group <i>xconnect-group-name</i> p2p <i>xconnect-name</i>} [id [icc-based <i>icc-string</i> <i>umc-string</i>] [number <i>number</i>]</p> <p>Example:</p> <pre>RP/0/RP0/CPU0:router(config-cfm-dmn)# service ABC xconnect group X1 p2p ADB</pre>	<p>Configures and associates a service with the domain and enters CFM domain service configuration mode. You can specify that the service is used only for down MEPS, or associate the service with a bridge domain where MIPs and up MEPS will be created.</p> <p>The id sets the short MA name.</p>
Step 5	<p>mip auto-create {all lower-mep-only} {ccm-learning}</p> <p>Example:</p> <pre>RP/0/RP0/CPU0:router(config-cfm-dmn-svc)# mip auto-create all ccm-learning</pre>	<p>(Optional) Enables the automatic creation of MIPs in a bridge domain. ccm-learning option enables CCM learning for MIPs created in this service. This must be used only in services with a relatively long CCM interval of at least 100 ms. CCM learning at MIPs is disabled by default.</p>
Step 6	<p>end or commit</p> <p>Example:</p> <pre>RP/0/RP0/CPU0:router(config-cfm-dmn-svc)# commit</pre>	<p>Saves configuration changes.</p> <ul style="list-style-type: none"> When you use the end command, the system prompts you to commit changes: <pre>Uncommitted changes found, commit them before exiting (yes/no/cancel)? [cancel]:</pre> Entering yes saves configuration changes to the running configuration file, exits the configuration session, and returns the router to EXEC mode. Entering no exits the configuration session and returns the router to EXEC mode without committing the configuration changes. Entering cancel leaves the router in the current configuration session without exiting or committing the configuration changes. Use the commit command to save the configuration changes to the running configuration file and remain within the configuration session.

Configuring Cross-Check on a MEP for a CFM Service

To configure cross-check on a MEP for a CFM service and specify the expected set of MEPS, complete the following steps:

SUMMARY STEPS

1. **configure**
2. **ethernet cfm**
3. **domain** *domain-name level level-value* [**id** [null]] [**dns** *DNS-name*] [**mac** *H.H.H*] [**string** *string*]]
4. **service** *service-name* {**bridge group** *bridge-domain-group* **bridge-domain** *bridge-domain-name* | **down-meps** | **xconnect group** *xconnect-group-name* **p2p** *xconnect-name*} [**id** [**icc-based** *icc-string umc-string*] | [**string** *text*] | [**number** *number*] | [**vlan-id** *id-number*] | [**vpn-id** *oui-vpnid*]]
5. **mep crosscheck**
6. **mep-id** *mep-id-number* [**mac-address** *mac-address*]
7. **end** or **commit**

DETAILED STEPS

	Command or Action	Purpose
Step 1	configure Example: RP/0/RP0/CPU0:router# configure	Enters global configuration mode.
Step 2	ethernet cfm Example: RP/0/RP0/CPU0:router# ethernet cfm	Enters the Ethernet Connectivity Fault Management (CFM) configuration mode.
Step 3	domain <i>domain-name level level-value</i> [id [null]] [dns <i>DNS-name</i>] [mac <i>H.H.H</i>] [string <i>string</i>]] Example: RP/0/RP0/CPU0:router(config-cfm)# domain Domain_One level 1 id string D1	Creates and names a container for all domain configurations and enters the CFM domain configuration mode. The level must be specified. The id is the maintenance domain identifier (MDID) and is used as the first part of the maintenance association identifier (MAID) in CFM frames. If the MDID is not specified, the domain name is used as the MDID by default.
Step 4	service <i>service-name</i> { bridge group <i>bridge-domain-group</i> bridge-domain <i>bridge-domain-name</i> down-meps xconnect group <i>xconnect-group-name</i> p2p <i>xconnect-name</i> } [id [icc-based <i>icc-string umc-string</i>] [string <i>text</i>] [number <i>number</i>] [vlan-id <i>id-number</i>] [vpn-id <i>oui-vpnid</i>]] Example: RP/0/RP0/CPU0:router(config-cfm-dmn)# service Bridge_Service bridge group BD1 bridge-domain B1	Configures and associates a service with the domain and enters CFM domain service configuration mode. You can specify that the service is used only for down MEPs, or associate the service with a bridge domain or xconnect where MIPs and up MEPs will be created. The id sets the short MA name.
Step 5	mep crosscheck Example: RP/0/RP0/CPU0:router(config-cfm-dmn-svc)# mep crosscheck mep-id 10	Enters CFM MEP crosscheck configuration mode.

	Command or Action	Purpose
Step 6	mep-id <i>mep-id-number</i> [mac-address <i>mac-address</i>] Example: RP/0/RP0/CPU0:router(config-cfm-xcheck)# mep-id 10	Enables cross-check on a MEP. Note <ul style="list-style-type: none"> Repeat this command for every MEP that you want included in the expected set of MEPs for cross-check.
Step 7	end or commit Example: RP/0/RP0/CPU0:router(config-cfm-xcheck)# commit	Saves configuration changes. <ul style="list-style-type: none"> When you use the end command, the system prompts you to commit changes: Uncommitted changes found, commit them before exiting (yes/no/cancel)? [cancel]: Entering yes saves configuration changes to the running configuration file, exits the configuration session, and returns the router to EXEC mode. Entering no exits the configuration session and returns the router to EXEC mode without committing the configuration changes. Entering cancel leaves the router in the current configuration session without exiting or committing the configuration changes. Use the commit command to save the configuration changes to the running configuration file and remain within the configuration session.

Configuring Other Options for a CFM Service

To configure other options for a CFM service, complete the following steps:

SUMMARY STEPS

- configure**
- ethernet cfm**
- domain** *domain-name* **level** *level-value* [**id** [**null**] [**dns** *DNS-name*] [**mac** *H.H.H*] [**string** *string*]]
- service** *service-name* {**bridge group** *bridge-domain-group* **bridge-domain** *bridge-domain-name* | **down-meps** | **xconnect group** *xconnect-group-name* **p2p** *xconnect-name*} [**id** [**icc-based** *icc-string* *umc-string*] | [**string** *text*] | [**number** *number*] | [**vlan-id** *id-number*] | [**vpn-id** *oui-vpnid*]]
- maximum-meps** *number*
- log** {**ais**|**continuity-check errors**|**continuity-check mep changes**|**crosscheck errors**|**efd**}
- end** or **commit**

DETAILED STEPS

	Command or Action	Purpose
Step 1	configure Example: RP/0/RP0/CPU0:router# configure	Enters global configuration mode.
Step 2	ethernet cfm Example: RP/0/RP0/CPU0:router# ethernet cfm	Enters the Ethernet Connectivity Fault Management (CFM) configuration mode.
Step 3	domain domain-name level level-value [id [null] [dns DNS-name] [mac H.H.H] [string string]] Example: RP/0/RP0/CPU0:router(config-cfm)# domain Domain_One level 1 id string D1	<p>Creates and names a container for all domain configurations and enters the CFM domain configuration mode.</p> <p>The level must be specified.</p> <p>The id is the maintenance domain identifier (MDID) and is used as the first part of the maintenance association identifier (MAID) in CFM frames. If the MDID is not specified, the domain name is used as the MDID by default.</p>
Step 4	service service-name {bridge group bridge-domain-group bridge-domain bridge-domain-name down-meps xconnect group xconnect-group-name p2p xconnect-name} [id [icc-based icc-string umc-string] [string text] [number number] [vlan-id id-number] [vpn-id oui-vpnid]] Example: RP/0/RP0/CPU0:router(config-cfm-dmn)# service Bridge_Service bridge group BD1 bridge-domain B1	<p>Configures and associates a service with the domain and enters CFM domain service configuration mode. You can specify that the service is used only for down MEPs, or associate the service with a bridge domain or xconnect where MIPs and up MEPs will be created.</p> <p>The id sets the short MA name.</p>
Step 5	maximum-meps number Example: RP/0/RP0/CPU0:router(config-cfm-dmn-svc)# maximum-meps 1000	(Optional) Configures the maximum number (2 to 8190) of MEPs across the network, which limits the number of peer MEPs recorded in the database.
Step 6	log {ais continuity-check errors continuity-check mep changes crosscheck errors efd} Example: RP/0/RP0/CPU0:router(config-cfm-dmn-svc)# log continuity-check errors	(Optional) Enables logging of certain types of events.
Step 7	end or commit Example: RP/0/RP0/CPU0:router(config-cfm-dmn-svc)# commit	<p>Saves configuration changes.</p> <ul style="list-style-type: none"> When you use the end command, the system prompts you to commit changes:

	Command or Action	Purpose
		<p>Uncommitted changes found, commit them before exiting (yes/no/cancel)? [cancel]:</p> <ul style="list-style-type: none"> • Entering yes saves configuration changes to the running configuration file, exits the configuration session, and returns the router to EXEC mode. • Entering no exits the configuration session and returns the router to EXEC mode without committing the configuration changes. • Entering cancel leaves the router in the current configuration session without exiting or committing the configuration changes. • Use the commit command to save the configuration changes to the running configuration file and remain within the configuration session.

Configuring CFM MEPs

- For every subinterface configured under a Layer 3 parent interface, you must associate a unique 802.1Q or 802.1ad tag. Else, it leads to unknown network behavior.

SUMMARY STEPS

1. **configure**
2. **interface** {**HundredGigE** | **TenGigE**} *interface-path-id*
3. **interface** {**HundredGigE** | **TenGigE** | **Bundle-Ether**} *interface-path-id.subinterface*
4. **vrf vrf-name**
5. **interface** {**HundredGigE** | **TenGigE**} *interface-path-id*
6. **ethernet cfm**
7. **mep domain** *domain-name* **service** *service-name* **mep-id** *id-number*
8. **cos** *cos*
9. **end** or **commit**

DETAILED STEPS

	Command or Action	Purpose
Step 1	configure Example: RP/0/RP0/CPU0:router# <code>configure</code>	Enters global configuration mode.

	Command or Action	Purpose
Step 2	interface { HundredGigE TenGigE } <i>interface-path-id</i> Example: <pre>RP/0/RP0/CPU0:router(config)# interface TenGigE 0/0/0/1</pre>	Type of Ethernet interface on which you want to create a MEP. Enter HundredGigE or TenGigE and the physical interface or virtual interface. Note <ul style="list-style-type: none"> Use the show interfaces command to see a list of all interfaces currently configured on the router.
Step 3	interface { HundredGigE TenGigE Bundle-Ether } <i>interface-path-id.subinterface</i> Example: <pre>RP/0/RP0/CPU0:router(config)# interface TenGigE 0/0/0/1</pre>	Type of Ethernet interface on which you want to create a MEP. Enter HundredGigE , TenGigE , or Bundle-Ether and the physical interface or virtual interface followed by the subinterface path ID. Naming convention is <i>interface-path-id.subinterface</i> . The period in front of the subinterface value is required as part of the notation.
Step 4	vrf <i>vrf-name</i> Example: <pre>RP/0/RP0/CPU0:router(config-if)# vrf vrf_A</pre>	Configures a VRF instance and enters VRF configuration mode.
Step 5	interface { HundredGigE TenGigE } <i>interface-path-id</i> Example: <pre>RP/0/RP0/CPU0:router(config)# interface TenGigE 0/0/0/1</pre>	Type of Ethernet interface on which you want to create a MEP. Enter HundredGigE or TenGigE and the physical interface or virtual interface. Note <ul style="list-style-type: none"> Use the show interfaces command to see a list of all interfaces currently configured on the router.
Step 6	ethernet cfm Example: <pre>RP/0/RP0/CPU0:router(config-if)# ethernet cfm</pre>	Enters interface Ethernet CFM configuration mode.
Step 7	mep domain <i>domain-name</i> service <i>service-name</i> mep-id <i>id-number</i> Example: <pre>RP/0/RP0/CPU0:router(config-if-cfm)# mep domain Dm1 service Sv1 mep-id 1</pre>	Creates a maintenance end point (MEP) on an interface and enters interface CFM MEP configuration mode.
Step 8	cos <i>cos</i> Example: <pre>RP/0/RP0/CPU0:router(config-if-cfm-mep)# cos 7</pre>	(Optional) Configures the class of service (CoS) (from 0 to 7) for all CFM packets generated by the MEP on an interface. If not configured, the CoS is inherited from the Ethernet interface.

	Command or Action	Purpose
		<p>Note For Ethernet interfaces, the CoS is carried as a field in the VLAN tag. Therefore, CoS only applies to interfaces where packets are sent with VLAN tags. If the cos (CFM) command is executed for a MEP on an interface that does not have a VLAN encapsulation configured, it will be ignored.</p>
Step 9	<p>end or commit</p> <p>Example:</p> <pre>RP/0/RP0/CPU0:router(config-if-cfm-mep) # commit</pre>	<p>Saves configuration changes.</p> <ul style="list-style-type: none"> When you use the end command, the system prompts you to commit changes: <pre>Uncommitted changes found, commit them before exiting (yes/no/cancel)? [cancel]:</pre> Entering yes saves configuration changes to the running configuration file, exits the configuration session, and returns the router to EXEC mode. Entering no exits the configuration session and returns the router to EXEC mode without committing the configuration changes. Entering cancel leaves the router in the current configuration session without exiting or committing the configuration changes. Use the commit command to save the configuration changes to the running configuration file and remain within the configuration session.

Configuring Y.1731 AIS

This section has the following step procedures:

Configuring AIS in a CFM Domain Service

Use the following procedure to configure Alarm Indication Signal (AIS) transmission for a CFM domain service and configure AIS logging.

SUMMARY STEPS

1. **configure**
2. **ethernet cfm**
3. **domain name level level**
4. **service name bridge group name bridge-domain name**
5. **service name xconnect group xconnect-group-name p2p xconnect-name**
6. **ais transmission [interval {1s|1m}][cos cos]**

7. **log ais**
8. **end** or **commit**

DETAILED STEPS

	Command or Action	Purpose
Step 1	configure Example: RP/0/RP0/CPU0:router# configure	Enters global configuration mode.
Step 2	ethernet cfm Example: RP/0/RP0/CPU0:router(config)# ethernet cfm	Enters Ethernet CFM global configuration mode.
Step 3	domain name level level Example: RP/0/RP0/CPU0:router(config-cfm)# domain D1 level 1	Specifies the domain and domain level.
Step 4	service name bridge group name bridge-domain name Example: RP/0/RP0/CPU0:router(config-cfm-dmn)# service S1 bridge group BG1 bridge-domain BD2	Specifies the service, bridge group, and bridge domain.
Step 5	service name xconnect group xconnect-group-name p2p xconnect-name Example: RP/0/RP0/CPU0:router(config-cfm-dmn)# service S1 xconnect group XG1 p2p X2	Specifies the service and cross-connect group and name.
Step 6	ais transmission [interval {1s 1m}][cos cos] Example: RP/0/RP0/CPU0:router(config-cfm-dmn-svc)# ais transmission interval 1m cos 7	Configures Alarm Indication Signal (AIS) transmission for a Connectivity Fault Management (CFM) domain service.
Step 7	log ais Example: RP/0/RP0/CPU0:router(config-cfm-dmn-svc)# log ais	Configures AIS logging for a Connectivity Fault Management (CFM) domain service to indicate when AIS or LCK packets are received.
Step 8	end or commit Example:	Saves configuration changes. <ul style="list-style-type: none"> • When you issue the end command, the system prompts you to commit changes:

	Command or Action	Purpose
	<pre>RP/0/RP0/CPU0:router(config-sla-prof-stat-cfg)# commit</pre>	<p>Uncommitted changes found, commit them before exiting (yes/no/cancel)? [cancel]:</p> <ul style="list-style-type: none"> • Entering yes saves configuration changes to the running configuration file, exits the configuration session, and returns the router to EXEC mode. • Entering no exits the configuration session and returns the router to EXEC mode without committing the configuration changes. • Entering cancel leaves the router in the current configuration session without exiting or committing the configuration changes. • Use the commit command to save the configuration changes to the running configuration file and remain within the configuration session.

Configuring AIS on a CFM Interface

To configure AIS on a CFM interface, perform the following steps:

SUMMARY STEPS

1. **configure**
2. **interface gigabitethernet** *interface-path-id*
3. **ethernet cfm**
4. **ais transmission up interval 1m cos** *cos*
5. **end** or **commit**

DETAILED STEPS

	Command or Action	Purpose
Step 1	<p>configure</p> <p>Example:</p> <pre>RP/0/RP0/CPU0:router# configure</pre>	Enters global configuration mode.
Step 2	<p>interface gigabitethernet <i>interface-path-id</i></p> <p>Example:</p> <pre>RP/0/RP0/CPU0:router# interface TenGigE 0/0/0/2</pre>	Enters interface configuration mode.
Step 3	<p>ethernet cfm</p> <p>Example:</p>	Enters Ethernet CFM interface configuration mode.

	Command or Action	Purpose
	<pre>RP/0/RP0/CPU0:router(config)# ethernet cfm</pre>	
Step 4	<p>ais transmission up interval 1m cos <i>cos</i></p> <p>Example:</p> <pre>RP/0/RP0/CPU0:router(config-if-cfm)# ais transmission up interval 1m cos 7</pre>	Configures Alarm Indication Signal (AIS) transmission on a Connectivity Fault Management (CFM) interface.
Step 5	<p>end or commit</p> <p>Example:</p> <pre>RP/0/RP0/CPU0:router(config-sla-prof-stat-cfg)# commit</pre>	<p>Saves configuration changes.</p> <ul style="list-style-type: none"> When you issue the end command, the system prompts you to commit changes: <pre>Uncommitted changes found, commit them before exiting(yes/no/cancel)? [cancel]:</pre> Entering yes saves configuration changes to the running configuration file, exits the configuration session, and returns the router to EXEC mode. Entering no exits the configuration session and returns the router to EXEC mode without committing the configuration changes. Entering cancel leaves the router in the current configuration session without exiting or committing the configuration changes. Use the commit command to save the configuration changes to the running configuration file and remain within the configuration session.

Configuring Flexible VLAN Tagging for CFM

Use this procedure to set the number of tags in CFM packets in a CFM domain service.

SUMMARY STEPS

- configure**
- ethernet cfm**
- domain *name* level *level***
- service *name* bridge group *name* bridge-domain *name***
- tags *number***
- end or commit**

DETAILED STEPS

	Command or Action	Purpose
Step 1	configure Example: RP/0/RP0/CPU0:router# configure	Enters global configuration mode.
Step 2	ethernet cfm Example: RP/0/RP0/CPU0:router(config)# ethernet cfm	Enters Ethernet CFM global configuration mode.
Step 3	domain name level level Example: RP/0/RP0/CPU0:router(config-cfm)# domain D1 level 1	Specifies the domain and domain level.
Step 4	service name bridge group name bridge-domain name Example: RP/0/RP0/CPU0:router(config-cfm-dmn)# service S2 bridge group BG1 bridge-domain BD2	Specifies the service, bridge group, and bridge domain.
Step 5	tags number Example: RP/0/RP0/CPU0:router(config-cfm-dmn-svc)# tags 1	Specifies the number of tags in CFM packets. Currently, the only valid value is 1.
Step 6	end or commit Example: RP/0/RP0/CPU0:router(config-cfm-dmn-svc)# commit	Saves configuration changes. <ul style="list-style-type: none"> When you issue the end command, the system prompts you to commit changes: Uncommitted changes found, commit them before exiting(yes/no/cancel)? [cancel]: Entering yes saves configuration changes to the running configuration file, exits the configuration session, and returns the router to EXEC mode. Entering no exits the configuration session and returns the router to EXEC mode without committing the configuration changes. Entering cancel leaves the router in the current configuration session without exiting or committing the configuration changes.

	Command or Action	Purpose
		<ul style="list-style-type: none"> Use the commit command to save the configuration changes to the running configuration file and remain within the configuration session.

Verifying the CFM Configuration

To verify the CFM configuration, use one or more of the following commands:

show ethernet cfm configuration-errors [domain <i>domain-name</i>] [interface <i>interface-path-id</i>]	Displays information about errors that are preventing configured CFM operations from becoming active, as well as any warnings that have occurred.
show ethernet cfm local maintenance-points <i>domain name</i> [service name] [interface type <i>interface-path-id</i>] [mep mip]	Displays a list of local maintenance points.



Note After you configure CFM, the error message, *cfmd[317]: %L2-CFM-5-CCM_ERROR_CCMS_MISSED : Some received CCMs have not been counted by the CCM error counters*, may display. This error message does not have any functional impact and does not require any action from you.

Troubleshooting Tips

To troubleshoot problems within the CFM network, perform these steps:

SUMMARY STEPS

- To verify connectivity to a problematic MEP, use the **ping ethernet cfm** command as shown in this example:
- If the results of the **ping ethernet cfm** command show a problem with connectivity to the peer MEP, use the **tracert ethernet cfm** command to help further isolate the location of the problem as shown in the following example:

DETAILED STEPS

Step 1 To verify connectivity to a problematic MEP, use the **ping ethernet cfm** command as shown in this example:

```
RP/0/RP0/CPU0:router# ping ethernet cfm domain D1 service S1 mep-id 16 source
interface TenGigE 0/0/0/1
```

```
Type escape sequence to abort.
Sending 5 CFM Loopbacks, timeout is 2 seconds -
Domain foo (level 2), Service foo
Source: MEP ID 1, interface TenGigE0/0/0/1
Target: 0001.0002.0003 (MEP ID 16):
Running (5s) ...
Success rate is 60.0 percent (3/5), round-trip min/avg/max = 1251/1349/1402 ms
Out-of-sequence: 0.0 percent (0/3)
```

```
Bad data: 0.0 percent (0/3)
Received packet rate: 1.4 pps
```

Step 2 If the results of the **ping ethernet cfm** command show a problem with connectivity to the peer MEP, use the **traceroute ethernet cfm** command to help further isolate the location of the problem as shown in the following example:

```
RP/0/RP0/CPU0:router# traceroute ethernet cfm domain D1 service S1 mep-id 16 source interface TenGigE 0/0/0/2
```

```
Traceroutes in domain D1 (level 4), service S1
Source: MEP-ID 1, interface TenGigE0/0/0/2
```

```
=====
Traceroute at 2009-05-18 12:09:10 to 0001.0203.0402,
TTL 64, Trans ID 2:
```

Hop	Hostname/Last	Ingress MAC/name	Egress MAC/Name	Relay
1	ios 0000-0001.0203.0400	0001.0203.0400 [Down] TenGigE0/0/0/2		FDB
2	abc ios		0001.0203.0401 [Ok] Not present	FDB
3	bcd abc	0001.0203.0402 [Ok] TenGigE0/0		Hit

```
Replies dropped: 0
```

If the target was a MEP, verify that the last hop shows “Hit” in the Relay field to confirm connectivity to the peer MEP.

If the Relay field contains “MPDB” for any of the hops, then the target MAC address was not found in the bridge MAC learning table at that hop, and the result is relying on CCM learning. This result can occur under normal conditions, but it can also indicate a problem. If you used the **ping ethernet cfm** command before using the **traceroute ethernet cfm** command, then the MAC address should have been learned. If “MPDB” is appearing in that case, then this indicates a problem at that point in the network.

CFM Over Bundles

CFM over bundle supports the following:

- CFM Maintenance Points—Up Maintenance-association End Points (MEP), Down MEP, and MIP, which includes L2 bundle main and sub-interfaces.
- CCM interval of 100 microsecond, 1second, 10 seconds, and 1 minute. CCM interval of 10 minutes is supported only in the versions earlier than IOS XR 7.3.2.
- RP OIR/VM reload, without impacting learned CFM peer MEPs.
- Process restart without impacting CFM sessions.
- CFM MEPs on bundle interfaces as software-offloaded-MEPs with all possible rewrite and encapsulation combinations supported by L2 sub-interfaces.
- CCM learning on MIP over bundle interfaces. CCM database learning supports investigation of one CCM out of 50 that goes over MIP.
- Static and dynamic MEPs.

Restrictions for Configuration of CFM on Bundles

Following are the restrictions for configuring CFM over bundle member interfaces:

- Only Layer 2 bundle Ethernet interfaces and sub-interfaces are supported except for those matching the VLAN tag `any`.
- CCM interval of 3.3 milliseconds and 10 milliseconds are not supported.
- CCM interval of 10 minutes is not supported from IOS XR 7.3.2.
- Supports 5000 pps rates of CCM traffic for bundle interfaces.
- Ethernet CFM is not supported with MEP that are configured on default and untagged encapsulated sub-interfaces that are part of a single physical interface.

Unidirectional Link Detection Protocol

Unidirectional Link Detection (UDLD) is a single-hop physical link protocol for monitoring an ethernet link, including both point-to-point and shared media links. This is a Cisco-proprietary protocol to detect link problems, which are not detected at the physical link layer. This protocol is specifically targeted at possible wiring errors, when using unbundled fiber links, where there can be a mismatch between the transmitting and receiving connections of a port.

Limitations

- UDLD must not be enabled on a Switched Port Analyzer (SPAN) source or a destination port.
- UDLD must not be enabled on a port that acts as a source or destination port for SPAN.

Types of Fault Detection

UDLD can detect these types of faults:

- Transmit faults — These are cases where there is a failure in transmitting packets from the local port to the peer device, but packets are being received from the peer. These faults are caused by failure of the physical link (where notification at layer 1 of unidirectional link faults is not supported by the media) as well as packet path faults on the local or peer device.
- Miswiring faults — These are cases where the receiving and transmitting sides of a port on the local device are connected to different peer ports (on the same device or on different devices). This can occur when using unbundled fibers to connect fiber optic ports.
- Loopback faults — These are cases where the receiving and transmitting sides of a port are connected to each other, creating a loopback condition. This can be an intentional mode of operation, for certain types of testing, but UDLD must not be used in these cases.
- Receive faults — The protocol includes a heartbeat signal that is transmitted at a negotiated periodic interval to the peer device. Missed heartbeats can therefore be used to detect failures on the receiving side of the link (where they do not result in interface state changes). These could be caused by a unidirectional link with a failure only affecting the receiving side, or by a link which has developed a bidirectional fault. This detection depends on reliable, regular packet transmission by the peer device. For this reason, the UDLD protocol has two (configurable) modes of operation which determine the

behavior on a heartbeat timeout. These modes are described in the section [UDLD Modes of Operation, on page 48](#).

UDLD Modes of Operation

UDLD can operate in these modes:

- **Normal mode:** In this mode, if a `Receive Fault` is detected, the user is informed and no further action is taken.
- **Aggressive mode:** In this mode, if a `Receive Fault` is detected, the user is informed and the affected port is disabled.



Note The difference of behavior between normal and aggressive modes is only seen in case of neighbor timeout. In all other cases, irrespective of the normal or aggressive mode, the system error disables a link once a unidirectional link is detected.

Configure UDLD

UDLD is configured for each interface. The interface must be a physical ethernet interface.

Perform the following steps to configure UDLD protocol on an interface:

```
RP/0/RSP0/CPU0:router# configure
RP/0/RSP0/CPU0:router(config)# interface TenGigE 0/1/0/0
```



Note The example indicates an 8-port 10-Gigabit Ethernet interface in modular services card slot 1.

Running Configuration

```
RP/0/RSP0/CPU0:router(config-if)# ethernet udldRP/0/RSP0/CPU0:router(config-if-udld)# mode?
RP/0/RP0/CPU0:IOS(config)#interface tenGigE 0/0/0/0
RP/0/RP0/CPU0:IOS(config-if)#ethernet udld
RP/0/RP0/CPU0:IOS(config-if-udld)#mode ?
    aggressive  Run UDLD in aggressive mode
    normal      Run UDLD in normal mode
RP/0/RP0/CPU0:IOS(config-if-udld)#mode aggressive
RP/0/RP0/CPU0:IOS(config-if-udld)#message-time ?
    <7-90> 'Mslow' message time (in seconds) to use for the UDLD protocol
RP/0/RP0/CPU0:IOS(config-if-udld)#message-time 50
```



```

RP/0/RP0/CPU0:IOS(config-if-udld)#destination mac-address ?
  H.H.H
      A valid multicast MAC address

  cisco-l2cp          Use the Cisco L2CP MAC address (used by CDP)

  ieee-slow-protocols Use the IEEE slow protocol destination MAC address
RP/0/RP0/CPU0:IOS(config-if-udld)#destination mac-address 0100.5e01.0101

RP/0/RP0/CPU0:IOS(config-if-udld)#logging disable

RP/0/RP0/CPU0:IOS(config-if-udld)#commit

RP/0/RP0/CPU0:IOS(config-if-udld)#end

RP/0/RP0/CPU0:IOS#sh run interface tenGigE 0/0/0/0
interface TenGigE0/0/0/0

  ethernet udld

  mode aggressive

  message-time 50

  destination mac-address 0100.5e01.0101

  logging disable

!
!

```

Verification

```

RP/0/RP0/CPU0:IOS#sh ethernet udld interfaces

Device ID:                00:8a:96:e1:20:d8

Device name:              IOS

Interface TenGigE0/0/0/0

Port state:               Up

Main FSM state:           Advertising

Detection FSM state:      Unknown

Message interval:         7 seconds

Timeout interval:        5 seconds

Destination MAC:          01:00:5e:01:01:01

RP/0/RP0/CPU0:IOS#sh ethernet udld statistics tenGigE 0/0/0/0

Interface TenGigE0/0/0/0

Counters last cleared:    00:01:18 ago

Main FSM transitions (to each state)

```

```

Link up:      1
Detection:    0
Advertise:    1

Port shutdown: 0
UDLD inactive: 0

Detection FSM transitions (to each state)

Unknown: 0
Bidirectional: 0
Unidirectional: 0
Neighbor mismatch: 0

Loopback: 0

Rx packet counts
Probe: 0

Echo:                                0
Flush:                                0
Invalid packets (dropped):            0

Tx packet counts
Probe:                                19
Echo:                                0
Flush:                                0
Unable to send (dropped):              0

RP/0/RP0/CPU0:IOS#
RP/0/RP0/CPU0:IOS#sh ethernet udld daemon database

Interface TenGigE0/0/0/0

```

Item	Value
Interface handle	Te0/0/0/0 (0x00000200)
Name	Te0/0/0/0
Name (long internal format)	TenGigE0_0_0_0
Configured ?	TRUE
Caps add in progress ?	FALSE
Caps remove in progress ?	FALSE
Caps added ?	TRUE
Protocol start pending ?	FALSE
Protocol running ?	TRUE
Registered for packet I/O ?	TRUE

```

Aggressive mode ?           TRUE
Logging enabled ?          FALSE
Error disabled on start ?   FALSE
Error disabled during ISSU ? FALSE
Attributes read ?          TRUE
Pending state down nfn ?    FALSE
Message time                50

```

Y.1731 Performance Monitoring

Table 5: Feature History Table

Feature Name	Release	Description
Cisco NC57 Native Mode: Y.1731 Loss and Delay Measurement	Release 7.3.1	This feature is now supported on routers that have the Cisco NC57 line cards installed and operate in the native mode.

Y.1731 Performance Monitoring (PM) provides a standard Ethernet PM function that includes measurement of Ethernet frame delay, frame delay variation, frame loss, and frame throughput measurements. This is specified by the ITU-T Y-1731 standard and interpreted by the Metro Ethernet Forum (MEF) standards group.

The router supports the following:

- Delay Measurement (DM)
- Synthetic Loss Measurement (SLM)

Two-Way Delay Measurement for Scalability

Use the Ethernet frame delay measurement to measure frame delay and frame delay variations. The system measures the Ethernet frame delay by using the Delay Measurement Message (DMM) method.

Restrictions for Configuring Two-Way Delay Measurement

Follow the guidelines and restrictions listed here when you configure two-way delay measurement:

- Y.1731 PM does not support One-Way DMM since PTP support is not available in the Release 6.3.1 for NCS 5500.
- System supports software-based timestamping for Two-Way DMM for NCS5502 and NCS5508 routers. The restriction is only applicable to UP MEP (Maintenance association End Point), which requires core NPU (Network Processor) and access NPU to have ToD (Time of Day) in sync to support 64-bit hardware-based timestamping. After you enable PTP (Precision Time Protocol) and sync all NPUs, the restriction is removed.

Configuring Two-Way Delay Measurement

Perform the following steps to configure two-way delay measurement:

```
RP/0/RP0/CPU0:router (config) # ethernet sla
```

```

profile DMM type cfm-delay-measurement
  probe
    send burst every 5 seconds packet count 5 interval 1 seconds
  !
  schedule
    every 1 minutes for 40 seconds
  !
  statistics
    measure round-trip-delay
      buckets size 1 probes
      buckets archive 5
    !
    measure round-trip-jitter
      buckets size 1 probes
      buckets archive 1
    !
  !
  !
  !
interface TenGigE0/0/0/10.1 l2transport
encapsulation dot1q 1
ethernet cfm
  mep domain DOWN0 service s10 mep-id 2001
  sla operation profile DMM target mep-id 6001
  !

```

Configuring an On-Demand Ethernet SLA Operation for CFM Delay Measurement

To configure an on-demand Ethernet SLA operation for CFM delay measurement, use this command in privileged EXEC configuration mode:

RP/0/RP0/CPU0:router (config) #

```

ethernet sla on-demand operation type cfm-synthetic-loss-measurement probe domain D1 source
interface TenGigE 0/6/1/0 target mac-address 2.3.4

```

Running Configuration

RP/0/RP0/CPU0:router# **show ethernet cfm peer meps**

Mon Sep 11 12:09:44.534 UTC

Flags:

```

> - Ok                               I - Wrong interval
R - Remote Defect received           V - Wrong level
L - Loop (our MAC received)         T - Timed out
C - Config (our ID received)        M - Missing (cross-check)
X - Cross-connect (wrong MAID)      U - Unexpected (cross-check)
* - Multiple errors received        S - Standby

```

Domain UP6 (level 6), Service s6
Up MEP on FortyGigE0/0/1/2.1 MEP-ID 1

```

=====
St   ID MAC Address   Port   Up/Downtime   CcmRcvd SeqErr   RDI Error
--  -
>   4001 70e4.227c.2865  Up     00:01:27     0       0       0       0

```

Domain DOWN0 (level 0), Service s10
Down MEP on TenGigE0/0/0/10.1 MEP-ID 2001

```

=====
St   ID MAC Address   Port   Up/Downtime   CcmRcvd SeqErr   RDI Error
--  -
>   6001 70e4.227c.287a  Up     00:02:11     0       0       0       0

```

RP/0/RP0/CPU0:router#

RP/0/RP0/CPU0:router# **show running-config**

```

Mon Sep 11 12:10:18.467 UTC
Building configuration...
!! IOS XR Configuration version = 6.4.1.14
!! Last configuration change at Mon Sep 11 12:08:16 2017 by root
!
logging console disable
telnet vrf default ipv4 server max-servers 10
username root
group root-lr
group cisco-support
secret 5 $1$QJT3$94M5/wK5J0v/lpAu/wz31/
!
line console
exec-timeout 0 0
!
ethernet cfm
domain UP6 level 6 id null
  service s6 xconnect group g1 p2p p1 id number 6
  mip auto-create all ccm-learning
  continuity-check interval 1s
  mep crosscheck
  mep-id 4001
  !
!
domain DOWN0 level 0 id null
  service s10 down-meps id number 10
  continuity-check interval 1s
  mep crosscheck
  mep-id 6001
  !
!
!
profile DMM type cfm-delay-measurement
  probe
    send burst every 5 seconds packet count 5 interval 1 seconds
  !
  schedule
    every 1 minutes for 40 seconds
  !
  statistics
    measure round-trip-delay
      buckets size 1 probes
      buckets archive 5
    !
    measure round-trip-jitter
      buckets size 1 probes
      buckets archive 1
    !
interface MgmtEth0/RP0/CPU0/0
shutdown
!
interface TenGigE0/0/0/0
shutdown
!
interface TenGigE0/0/0/1
shutdown
!
interface TenGigE0/0/0/2
shutdown
!
interface TenGigE0/0/0/3
shutdown

```

```
!  
interface TenGigE0/0/0/4  
shutdown  
!  
interface TenGigE0/0/0/5  
shutdown  
!  
interface TenGigE0/0/0/6  
shutdown  
!  
interface TenGigE0/0/0/7  
shutdown  
!  
interface TenGigE0/0/0/8  
shutdown  
!  
interface TenGigE0/0/0/9  
shutdown  
!  
interface TenGigE0/0/0/10.1 l2transport  
encapsulation dot1q 1  
ethernet cfm  
    mep domain DOWN0 service s10 mep-id 2001  
    sla operation profile DMM target mep-id 6001  
    sla operation profile test-slm target mep-id 6001  
!  
!  
interface TenGigE0/0/0/11  
shutdown  
!  
interface TenGigE0/0/0/12  
shutdown  
!  
interface TenGigE0/0/0/13  
shutdown  
!  
interface TenGigE0/0/0/14  
shutdown  
!  
interface TenGigE0/0/0/15  
shutdown  
!  
interface TenGigE0/0/0/16  
shutdown  
!  
interface TenGigE0/0/0/17  
shutdown  
!  
interface TenGigE0/0/0/18  
shutdown  
!  
interface TenGigE0/0/0/19  
shutdown  
!  
interface TenGigE0/0/0/20  
shutdown  
!  
interface TenGigE0/0/0/21  
shutdown  
!  
interface TenGigE0/0/0/22  
shutdown  
!
```

```
interface TenGigE0/0/0/23
shutdown
!
interface TenGigE0/0/0/24
shutdown
!
interface TenGigE0/0/0/25
shutdown
!
interface TenGigE0/0/0/26
shutdown
!
interface TenGigE0/0/0/27
shutdown
!
interface TenGigE0/0/0/28
shutdown
!
interface TenGigE0/0/0/29
shutdown
!
interface TenGigE0/0/0/30
shutdown
!
!
interface TenGigE0/0/0/31
shutdown
!
interface TenGigE0/0/0/32
shutdown
!
interface TenGigE0/0/0/33
shutdown
!
interface TenGigE0/0/0/34
shutdown
!
interface TenGigE0/0/0/35
shutdown
!
interface TenGigE0/0/0/36
shutdown
!
interface TenGigE0/0/0/37
shutdown
!
interface TenGigE0/0/0/38
shutdown
!
interface TenGigE0/0/0/39
shutdown
!
interface TenGigE0/0/1/0/1
shutdown
!
interface TenGigE0/0/1/0/2
shutdown
!
interface TenGigE0/0/1/0/3
shutdown
!
controller Optics0/0/1/0
breakout 4x10
!
```

```

interface HundredGigE0/0/1/1
 shutdown
 !
interface FortyGigE0/0/1/2.1 l2transport
 encapsulation dot1q 1
 ethernet cfm
  mep domain UP6 service s6 mep-id 1
   sla operation profile DMM target mep-id 6001
   sla operation profile test-slm target mep-id 6001
 !
 !
 !
l2vpn
 xconnect group g1
  p2p p1
   interface TenGigE0/0/0/10.1
   interface FortyGigE0/0/1/2.1
 !
 !
end

```

Verification

One-way Delay (Source->Dest)

~~~~~

1 probes per bucket

Bucket started at 12:11:19 UTC Mon 11 September 2017 lasting 10s

Pkts sent: 10; Lost: 0 (0.0%); Corrupt: 0 (0.0%);  
 Misordered: 0 (0.0%); Duplicates: 0 (0.0%)

Result count: 10

Min: 1912765.961ms; Max: 1912765.961ms; Mean: 1912765.961ms; StdDev: -2147483.648ms

One-way Delay (Dest->Source)

~~~~~

1 probes per bucket

Bucket started at 12:11:19 UTC Mon 11 September 2017 lasting 10s

Pkts sent: 10; Lost: 0 (0.0%); Corrupt: 0 (0.0%);
 Misordered: 0 (0.0%); Duplicates: 0 (0.0%)

Result count: 10

Min: -1912765.952ms; Max: -1912765.951ms; Mean: -1912765.951ms; StdDev: -2147483.648ms

Round Trip Jitter

~~~~~

1 probes per bucket

Bucket started at 12:11:19 UTC Mon 11 September 2017 lasting 10s

Pkts sent: 10; Lost: 0 (0.0%); Corrupt: 0 (0.0%);  
 Misordered: 0 (0.0%); Duplicates: 0 (0.0%)

Result count: 9

Min: 0.000ms; Max: 0.001ms; Mean: 0.000ms; StdDev: 0.000ms

One-way Jitter (Source->Dest)

~~~~~

1 probes per bucket

Bucket started at 12:11:19 UTC Mon 11 September 2017 lasting 10s

Pkts sent: 10; Lost: 0 (0.0%); Corrupt: 0 (0.0%);
 Misordered: 0 (0.0%); Duplicates: 0 (0.0%)

```

Result count: 9
Min: 0.000ms; Max: 0.000ms; Mean: 0.000ms; StdDev: 0.000ms

```

```

One-way Jitter (Dest->Source)
~~~~~

```

```

1 probes per bucket

```

```

Bucket started at 12:11:19 UTC Mon 11 September 2017 lasting 10s
  Pkts sent: 10; Lost: 0 (0.0%); Corrupt: 0 (0.0%);
    Misordered: 0 (0.0%); Duplicates: 0 (0.0%)
  Result count: 9
  Min: 0.000ms; Max: 0.001ms; Mean: 0.000ms; StdDev: 0.000ms

```

```

RP/0/RP0/CPU0:ios#ethernet sla on-demand operation type cfm-syn probe domain DOWN0 source
interface tenGigE 0/0/0/10.1 target mep-id 6001

```

```

Mon Sep 11 12:12:39.259 UTC

```

```

Warning: Burst configuration is present and so this profile cannot be represented in the
MEF-SOAM-PM-MIB configuration tables. However, the statistics are still collected

```

```

On-demand operation 2 succesfully created

```

```

/ - Completed - statistics will be displayed shortly.

```

```

RP/0/RP0/CPU0:ios#show ethernet sla statistics on-demand id 2

```

```

Mon Sep 11 12:13:24.825 UTC

```

```

Source: Interface TenGigE0/0/0/10.1, Domain DOWN0

```

```

Destination: Target MEP-ID 6001

```

```

=====
On-demand operation ID #2, packet type 'cfm-synthetic-loss-measurement'

```

```

Started at 12:12:41 UTC Mon 11 September 2017, runs once for 10s

```

```

Frame Loss Ratio calculated every 10s

```

```

One-way Frame Loss (Source->Dest)
~~~~~

```

```

1 probes per bucket

```

```

Bucket started at 12:12:41 UTC Mon 11 September 2017 lasting 10s
  Pkts sent: 100; Lost: 0 (0.0%); Corrupt: 0 (0.0%);
    Misordered: 0 (0.0%); Duplicates: 0 (0.0%)
  Result count: 1
  Min: 0.000%; Max: 0.000%; Mean: 0.000%; StdDev: 0.000%; Overall: 0.000%

```

```

One-way Frame Loss (Dest->Source)
~~~~~

```

```

1 probes per bucket

```

```

Bucket started at 12:12:41 UTC Mon 11 September 2017 lasting 10s
  Pkts sent: 100; Lost: 0 (0.0%); Corrupt: 0 (0.0%);
    Misordered: 0 (0.0%); Duplicates: 0 (0.0%)
  Result count: 1
  Min: 0.000%; Max: 0.000%; Mean: 0.000%; StdDev: 0.000%; Overall: 0.000%

```

```

RP/0/RP0/CPU0:ios#show ethernet cfm local meps verbose

```

```

Mon Sep 11 12:13:04.461 UTC

```

```

Domain UP6 (level 6), Service s6

```

```

Up MEP on FortyGigE0/0/1/2.1 MEP-ID 1

```

```

=====
Interface state: Up      MAC address: 008a.960f.c4a8
Peer MEPs: 1 up, 0 with errors, 0 timed out (archived)
Cross-check errors: 0 missing, 0 unexpected

```

```

CCM generation enabled: Yes, 1s (Remote Defect detected: No)
                        CCM processing offloaded to hardware

```

```

AIS generation enabled: No
Sending AIS:           No
Receiving AIS:        No

No packets sent/received

Domain DOWN0 (level 0), Service s10
Down MEP on TenGigE0/0/0/10.1 MEP-ID 2001
=====
Interface state: Up      MAC address: 008a.960f.c428
Peer MEPS: 1 up, 0 with errors, 0 timed out (archived)
Cross-check errors: 0 missing, 0 unexpected

CCM generation enabled: Yes, 1s (Remote Defect detected: No)
                        CCM processing offloaded to hardware
AIS generation enabled: No
Sending AIS:           No
Receiving AIS:        No

Packet      Sent      Received
-----
DMM         10         0
DMR          0         10
SLM        100         0
SLR          0        100

```

Synthetic Loss Measurement

The synthetic loss measurement mechanism defined in Y.1731 can only be used in point-to-point networks, and only works when there is sufficient flow of data traffic. The difficulties with the Y.1731 loss measurement mechanism was recognized across the industry and hence an alternative mechanism has been defined and standardized for measuring loss of traffic.

This alternative mechanism does not measure the loss of the actual data traffic, but instead injects synthetic CFM frames and measures the loss of these synthetic frames. You can perform a statistical analysis to give an approximation of the loss of data traffic. This technique is called Synthetic Loss Measurement (SLM). SLM has been included in the latest version of the Y.1731 standard. Use SLA to perform the following measurements:

- One-way loss (Source to Destination)
- One-way loss (Destination to Source)

SLM supports the following:

- All Layer 2 transport interfaces, such as physical, bundle interfaces, Layer2 sub-interfaces, pseudowire Head-end interfaces or attachment circuits. Transport network can be EVPN or BGP-MPLS.
- Up and Down MEPS.
- Transparent passing of the SLM packets through the MIP without punting it to the software.
- 100 concurrent SLM sessions.
- 1000 pps of SLM/SLR traffic.

Configuring Synthetic Loss Measurement

The following section describes how you can configure Synthetic Loss Measurement:

```

RP/0/RP0/CPU0:router (config)# ethernet sla
profile test-slm type cfm-synthetic-loss-measurement
  probe
    send packet every 1 seconds
    synthetic loss calculation packets 24
  !
  schedule
    every 3 minutes for 120 seconds
  !
  statistics
    measure one-way-loss-sd
      buckets size 1 probes
      buckets archive 5
    !
    measure one-way-loss-ds
      buckets size 1 probes
      buckets archive 5
  !
!
!
!
!
interface TenGigE0/0/0/10.1 12transport
encapsulation dot1q 1
ethernet cfm
  mep domain DOWN0 service s10 mep-id 2001
  sla operation profile test-slm target mep-id 6001
!

```

Configuring an On-Demand Ethernet SLA Operation for CFM Synthetic Loss Measurement

To configure an on-demand Ethernet SLA operation for CFM synthetic loss measurement, use this command in privileged EXEC configuration mode:

```

RP/0/RP0/CPU0:router (config) # ethernet sla on-demand operation type
cfm-synthetic-loss-measurement probe domain D1 source interface TenGigE
0/6/1/0 target mac-address 2.3.4

```

Running Configuration

```

RP/0/RP0/CPU0:router# show ethernet sla statistics on-demand id 1
Mon Sep 11 12:12:00.699 UTC
Source: Interface TenGigE0/0/0/10.1, Domain DOWN0
Destination: Target MEP-ID 6001
=====
On-demand operation ID #1, packet type 'cfm-delay-measurement'
RP/0/RP0/CPU0:router#
RP/0/RP0/CPU0:router# show running-config
Mon Sep 11 12:10:18.467 UTC
Building configuration...
!! IOS XR Configuration version = 6.4.1.14I
!! Last configuration change at Mon Sep 11 12:08:16 2017 by root
!
logging console disable
telnet vrf default ipv4 server max-servers 10
username root
group root-lr
group cisco-support
secret 5 $1$QJT3$94M5/wK5J0v/lpAu/wz31/
!
line console

```

```

exec-timeout 0 0
!
ethernet cfm
domain UP6 level 6 id null
  service s6 xconnect group g1 p2p p1 id number 6
  mip auto-create all ccm-learning
  continuity-check interval 1s
  mep crosscheck
  mep-id 4001
  !
!
domain DOWN0 level 0 id null
  service s10 down-meps id number 10
  continuity-check interval 1s
  mep crosscheck
  mep-id 6001
  !
!
!
!
profile test-slm type cfm-synthetic-loss-measurement
  probe
  send packet every 1 seconds
  synthetic loss calculation packets 24
  !
  schedule
  every 3 minutes for 120 seconds
  !
  statistics
  measure one-way-loss-sd
  buckets size 1 probes
  buckets archive 5
  !
  measure one-way-loss-ds
  buckets size 1 probes
  buckets archive 5
  !
interface MgmtEth0/RP0/CPU0/0
shutdown
!
interface TenGigE0/0/0/0
shutdown
!
interface TenGigE0/0/0/1
shutdown
!
interface TenGigE0/0/0/2
shutdown
!
interface TenGigE0/0/0/3
shutdown
!
interface TenGigE0/0/0/4
shutdown
!
interface TenGigE0/0/0/5
shutdown
!
interface TenGigE0/0/0/6
shutdown
!
interface TenGigE0/0/0/7
shutdown

```

```
!  
interface TenGigE0/0/0/8  
shutdown  
!  
interface TenGigE0/0/0/9  
shutdown  
!  
interface TenGigE0/0/0/10.1 l2transport  
encapsulation dot1q 1  
ethernet cfm  
    mep domain DOWN0 service s10 mep-id 2001  
    sla operation profile DMM target mep-id 6001  
    sla operation profile test-slm target mep-id 6001  
    !  
!  
!  
interface TenGigE0/0/0/11  
shutdown  
!  
interface TenGigE0/0/0/12  
shutdown  
!  
interface TenGigE0/0/0/13  
shutdown  
!  
interface TenGigE0/0/0/14  
shutdown  
!  
interface TenGigE0/0/0/15  
shutdown  
!  
interface TenGigE0/0/0/16  
shutdown  
!  
interface TenGigE0/0/0/17  
shutdown  
!  
interface TenGigE0/0/0/18  
shutdown  
!  
interface TenGigE0/0/0/19  
shutdown  
!  
interface TenGigE0/0/0/20  
shutdown  
!  
interface TenGigE0/0/0/21  
shutdown  
!  
interface TenGigE0/0/0/22  
shutdown  
!  
interface TenGigE0/0/0/23  
shutdown  
!  
interface TenGigE0/0/0/24  
shutdown  
!  
interface TenGigE0/0/0/25  
shutdown  
!  
interface TenGigE0/0/0/26  
shutdown  
!
```

```

interface TenGigE0/0/0/27
shutdown
!
interface TenGigE0/0/0/28
shutdown
!
interface TenGigE0/0/0/29
shutdown
!
interface TenGigE0/0/0/30
shutdown
!
!
interface TenGigE0/0/0/31
shutdown
!
interface TenGigE0/0/0/32
shutdown
!
interface TenGigE0/0/0/33
shutdown
!
interface TenGigE0/0/0/34
shutdown
!
interface TenGigE0/0/0/35
shutdown
!
interface TenGigE0/0/0/36
shutdown
!
interface TenGigE0/0/0/37
shutdown
!
interface TenGigE0/0/0/38
shutdown
!
interface TenGigE0/0/0/39
shutdown
!
interface TenGigE0/0/1/0/1
shutdown
!
interface TenGigE0/0/1/0/2
shutdown
!
interface TenGigE0/0/1/0/3
shutdown
!
controller Optics0/0/1/0
breakout 4x10
!
interface HundredGigE0/0/1/1
shutdown
!
interface FortyGigE0/0/1/2.1 l2transport
encapsulation dot1q 1
ethernet cfm
mep domain UP6 service s6 mep-id 1
sla operation profile DMM target mep-id 6001
sla operation profile test-slm target mep-id 6001
!
!
!
```

```

l2vpn
xconnect group g1
  p2p pl
    interface TenGigE0/0/0/10.1
    interface FortyGigE0/0/1/2.1
  !
!
!
end

```

Verification

Round Trip Delay

```

~~~~~
1 probes per bucket

```

```

Bucket started at 12:11:19 UTC Mon 11 September 2017 lasting 10s
  Pkts sent: 10; Lost: 0 (0.0%); Corrupt: 0 (0.0%);
    Misordered: 0 (0.0%); Duplicates: 0 (0.0%)
  Result count: 10
  Min: 0.009ms; Max: 0.010ms; Mean: 0.009ms; StdDev: 0.000ms

```

One-way Delay (Source->Dest)

```

~~~~~
1 probes per bucket

```

```

Bucket started at 12:11:19 UTC Mon 11 September 2017 lasting 10s
  Pkts sent: 10; Lost: 0 (0.0%); Corrupt: 0 (0.0%);
    Misordered: 0 (0.0%); Duplicates: 0 (0.0%)
  Result count: 10
  Min: 1912765.961ms; Max: 1912765.961ms; Mean: 1912765.961ms; StdDev: -2147483.648ms

```

One-way Delay (Dest->Source)

```

~~~~~
1 probes per bucket

```

```

Bucket started at 12:11:19 UTC Mon 11 September 2017 lasting 10s
  Pkts sent: 10; Lost: 0 (0.0%); Corrupt: 0 (0.0%);
    Misordered: 0 (0.0%); Duplicates: 0 (0.0%)
  Result count: 10
  Min: -1912765.952ms; Max: -1912765.951ms; Mean: -1912765.951ms; StdDev: -2147483.648ms

```

Round Trip Jitter

```

~~~~~
1 probes per bucket

```

```

Bucket started at 12:11:19 UTC Mon 11 September 2017 lasting 10s
  Pkts sent: 10; Lost: 0 (0.0%); Corrupt: 0 (0.0%);
    Misordered: 0 (0.0%); Duplicates: 0 (0.0%)
  Result count: 9
  Min: 0.000ms; Max: 0.001ms; Mean: 0.000ms; StdDev: 0.000ms

```

One-way Jitter (Source->Dest)

```

~~~~~
1 probes per bucket

```

```

Bucket started at 12:11:19 UTC Mon 11 September 2017 lasting 10s
  Pkts sent: 10; Lost: 0 (0.0%); Corrupt: 0 (0.0%);
    Misordered: 0 (0.0%); Duplicates: 0 (0.0%)
  Result count: 9

```

```
Min: 0.000ms; Max: 0.000ms; Mean: 0.000ms; StdDev: 0.000ms
```

```
One-way Jitter (Dest->Source)
```

```
~~~~~
```

```
1 probes per bucket
```

```
Bucket started at 12:11:19 UTC Mon 11 September 2017 lasting 10s
```

```
Pkts sent: 10; Lost: 0 (0.0%); Corrupt: 0 (0.0%);
```

```
Misordered: 0 (0.0%); Duplicates: 0 (0.0%)
```

```
Result count: 9
```

```
Min: 0.000ms; Max: 0.001ms; Mean: 0.000ms; StdDev: 0.000ms
```

Ethernet SLA Statistics Measurement in a Profile

Table 6: Feature History Table

Feature Name	Release Information	Feature Description
Enhancement to Ethernet SLA Statistics Measurement	Release 7.7.1	<p>You can now configure the size of bins that are used to aggregate the results of Ethernet SLA statistics, in microseconds. The size of the bins is defined by the width value of delay and jitter measurement in Ethernet SLA statistics. You can configure the width value ranging from 1 to 10000000 microseconds. This enhancement provides granularity to store more accurate results of Ethernet SLA statistics in the aggregate bins.</p> <p>In earlier releases, you could only configure the width value for the delay and jitter measurement in milliseconds.</p> <p>This feature introduces the usec keyword in the aggregate command.</p>

The Ethernet SLA feature supports measurement of one-way and two-way delay and jitter statistics, and one-way FLR statistics.

Ethernet SLA statistics measurement for network performance is performed by sending packets and storing data metrics such as:

- Round-trip delay time—The time for a packet to travel from source to destination and back to source again.
- Round-trip jitter—The variance in round-trip delay time (latency).
- One-way delay and jitter—The router also supports measurement of one-way delay or jitter from source to destination, or from destination to source.

- One-way frame loss—The router also supports measurement of one-way frame loss from source to destination, or from destination to source.

In addition to these metrics, these statistics are also kept for SLA probe packets:

- Packet loss count
- Packet corruption event
- Out-of-order event
- Frame Loss Ratio (FLR)

Counters for packet loss, corruption, and, out-of-order packets are kept for each bucket, and in each case, a percentage of the total number of samples for that bucket is reported (for example, 4% packet corruption). For delay, jitter, and loss statistics, the minimum, maximum, mean and standard deviation for the whole bucket are reported, as well as the individual samples or aggregated bins. Also, the overall FLR for the bucket, and individual FLR measurements or aggregated bins are reported for synthetic loss measurement statistics. The packet loss count is the overall number of measurement packets lost in either direction and the one-way FLR measures the loss in each direction separately.

When aggregation is enabled using the **aggregate** command, bins are created to store a count of the samples that fall within a certain value range, which is set by the **width** keyword. Only a counter of the number of results that fall within the range for each bin is stored. This uses less memory than storing individual results. When aggregation is not used, each sample is stored separately, which can provide a more accurate statistics analysis for the operation, but it is highly memory-intensive due to the independent storage of each sample.

A bucket represents a time period during which statistics are collected. All the results received during that time period are recorded in the corresponding bucket. If aggregation is enabled, each bucket has its own set of bins and counters, and only results relating to the measurements initiated during the time period represented by the bucket are included in those counters.

Frame Loss Ratio (FLR) is a primary attribute that can be calculated based on loss measurements. FLR is defined by the ratio of lost packets to sent packets and expressed as a percentage value. FLR is measured in each direction (source to destination and destination to source) separately. Availability is an attribute that is typically measured over a long period of time, such as weeks or months. The intent is to measure the proportion of time when there was prolonged high loss.

To configure one-way delay or jitter measurements, you must first configure the **profile (SLA)** command using the **type cfm-delay-measurement** form of the command.

For valid one-way delay results, you must have both local and remote devices time synchronized. In order to do this, you must select sources for frequency and time-of-day (ToD).

Frequency selection can be between any source of frequency available to the router, such as: BITS, GPS, SyncE, or PTP. The ToD selection is between the source selected for frequency and PTP or DTI. Note that NTP is not sufficient.

Configuration Guidelines



Caution Certain SLA configurations can use a large amount of memory which can affect the performance of other features on the router.

Before you configure Ethernet SLA, consider the following guidelines:

- Aggregation—Use of the **aggregate none** command significantly increases the amount of memory required because each individual measurement is recorded, rather than just counts for each aggregation bin. When you configure aggregation, consider that more bins will require more memory.
- Buckets archive—When you configure the **buckets archive** command, consider that the more history that is kept, the more memory will be used.
- Measuring two statistics (such as both delay and jitter) will use approximately twice as much memory as measuring one.
- Separate statistics are stored for one-way source-to-destination and destination-to-source measurements, which consumes twice as much memory as storing a single set of round-trip statistics.
- You must define the schedule before you configure SLA probe parameters to send probes for a particular profile. It is recommended to set up the profile—probe, statistics, and schedule before any commit.

Restrictions

One-way delay and jitter measurements are not supported by `cfm-loopback` profile types.

Configure Ethernet SLA Statistics Measurement in a Profile

To configure SLA statistics measurement in a profile, perform these steps:

1. Enter the Ethernet SLA configuration mode, using the **ethernet sla** command in Global Configuration mode.
2. Create an SLA operation profile with the **profile profile-name type cfm-delay-measurement** command.
3. Enable the collection of SLA statistics using the **statistics measure {one-way-delay-ds | one-way-delay-sd | one-way-jitter-ds | one-way-jitter-sd | round-trip-delay | round-trip-jitter | one-way-loss-ds | one-way-loss-sd}** command.
4. Configure the size and number of bins into which to aggregate the results of statistics collection. For delay measurements and data loss measurements, the default is that all values are aggregated into 1 bin. For synthetic loss measurements, by default the aggregation is disabled. Use the **aggregate {bins count width [usec] width | none}** command to configure the bins.
 - For delay and jitter measurements, you can configure a width value from 1 to 10000 milliseconds, if the number of bins is at least 2. To configure the width value in microseconds, use the **usec** option. You can configure the width value from 1 to 10000000 microseconds.
 - For data loss and synthetic loss measurements, you can configure a width value from 1 to 100 percentage points, if the number of bins is at least 2.
5. Configure the size of the buckets in which statistics are collected, using the **buckets size number probes** command.
6. Configure the number of buckets to store in memory using the **buckets archive number** command.
7. Save the configuration changes using the **end** or **commit** command.

Configuration Example

This example shows configuration of round-trip-delay statistics measurement in 5 bins each with a range of 123 microseconds:

```

Router(config)# ethernet sla
Router(config-sla)# profile test type cfm-delay-measurement
Router(config-sla-prof)# statistics measure round-trip-delay
Router(config-sla-prof-stat-cfg)# aggregate bins 5 width usec 123
Router(config-sla-prof-stat-cfg)# buckets size 1 probes
Router(config-sla-prof-stat-cfg)# buckets archive 50
Router(config-sla-prof-stat-cfg)# commit

```

This example shows configuration of round-trip-delay statistics measurement in 5 bins each with a range of 10 milliseconds:

```

Router(config)# ethernet sla
Router(config-sla)# profile test type cfm-delay-measurement
Router(config-sla-prof)# statistics measure round-trip-delay
Router(config-sla-prof-stat-cfg)# aggregate bins 5 width 10
Router(config-sla-prof-stat-cfg)# buckets size 1 probes
Router(config-sla-prof-stat-cfg)# buckets archive 50
Router(config-sla-prof-stat-cfg)# commit

```

Verification

This example displays aggregate bins configured with a range of 123 microseconds:

```

Router# show ethernet sla statistics detail
Tue Sep 28 07:59:22.340 PDT
Source: Interface GigabitEthernet0/0/0/2, Domain dom1
Destination: Target MAC Address 0012.0034.0056
=====
Profile 'test', packet type 'cfm-delay-measurement'
Scheduled to run every 1min first at 00:00:31 UTC for 10s

Round Trip Delay
~~~~~
1 probes per bucket

No stateful thresholds.

Bucket started at 07:56:31 PDT Tue 28 September 2021 lasting 10s
  Pkts sent: 10; Lost: 0 (0.0%); Corrupt: 0 (0.0%);
    Misordered: 0 (0.0%); Duplicates: 0 (0.0%)
  Result count: 10
  Min: 0.000ms, occurred at 07:56:32 PDT Tue 28 September 2021
  Max: 1.000ms, occurred at 07:56:31 PDT Tue 28 September 2021
  Mean: 0.100ms; StdDev: 0.300ms

  Bins:
  Range          Samples   Cum. Count   Mean
  -----
    0 to 0.123 ms  9 (90.0%)   9 (90.0%)   0.000ms
  0.123 to 0.246 ms 0 (0.0%)   9 (90.0%)   -
  0.246 to 0.369 ms 0 (0.0%)   9 (90.0%)   -
  0.369 to 0.492 ms 0 (0.0%)   9 (90.0%)   -
  > 0.492      ms 1 (10.0%)  10 (100.0%) 1.000ms

```

This example displays aggregate bins configured with a range of 10 milliseconds:

```

Router# show ethernet sla statistics detail
Tue Sep 28 08:00:57.527 PDT
Source: Interface GigabitEthernet0/0/0/2, Domain dom1
Destination: Target MAC Address 0012.0034.0056
=====
Profile 'test', packet type 'cfm-delay-measurement'

```

Scheduled to run every 1min first at 00:00:31 UTC for 10s

Round Trip Delay

~~~~~

1 probes per bucket

No stateful thresholds.

Bucket started at 08:00:32 PDT Tue 28 September 2021 lasting 10s

Pkts sent: 9; Lost: 0 (0.0%); Corrupt: 0 (0.0%);

Misordered: 1 (11.1%); Duplicates: 0 (0.0%)

Result count: 9

Min: 0.000ms, occurred at 08:00:32 PDT Tue 28 September 2021

Max: 0.000ms, occurred at 08:00:32 PDT Tue 28 September 2021

Mean: 0.000ms; StdDev: 0.000ms

Results suspect due to a probe starting mid-way through a bucket

Bins:

| Range       | Samples    | Cum. Count | Mean    |
|-------------|------------|------------|---------|
| 0 to 10 ms  | 9 (100.0%) | 9 (100.0%) | 0.000ms |
| 10 to 20 ms | 0 (0.0%)   | 9 (100.0%) | -       |
| 20 to 30 ms | 0 (0.0%)   | 9 (100.0%) | -       |
| 30 to 40 ms | 0 (0.0%)   | 9 (100.0%) | -       |
| > 40 ms     | 0 (0.0%)   | 9 (100.0%) | -       |

## Bit Error Rate

**Table 7: Feature History Table**

| Feature Name   | Release Information | Feature Description                                                                                                                                                                                                                                         |
|----------------|---------------------|-------------------------------------------------------------------------------------------------------------------------------------------------------------------------------------------------------------------------------------------------------------|
| Bit Error Rate | Release 7.4.1       | This functionality that informs you of the number of bit errors per unit time and helps you test cables and diagnose signal problems in the field is now supported on routers that have the Cisco NC57 line cards installed and operate in the native mode. |

In network transmission, data streaming over communication channels is susceptible to unplanned alterations during transmission. Such alterations are due to noise, interference, or synchronization errors. The number of bits thus received with alterations is measured as the number of bit errors.

Bit Error Rate (BER) is the number of bit errors per unit time or time window. For example, consider a scenario where the bit rate reaching the receiver is 10 bits per second, and the bit error is 1 bit per second. In this example, the BER is bit errors/unit time or time window = 1 bit/second.

Using this feature, you can test cables and diagnose signal problems in the field. You can display and analyze the total number of error bits transmitted and the total received on the link. Your router supports BER on 10/40/100 GE interfaces.

The error range measurement that your router supports is 10E-8 through 10E-12 bits, where E = \*10<sup>^</sup>. Thus, the error range is from:

$$10 * 10^{-8} = 10 \times 0.00000001 = 0.0000001 \text{ bits}$$

through

$$10 * 10^{-12} = 10 \times 0.000000000001 = 0.00000000001 \text{ bits}$$

Bit errors usually occur because of:

- Faulty or bad cables
- Loose cable connections at one or both ends

### How is Bit Error Rate Measured?

BER algorithm polls the hardware counters periodically for bit errors, every 500ms.

**For 40 GE and 100GE interfaces**, your router uses a physical coding sublayer (PCS) bit interleaved parity (BIP) error counter.

**For 10 GE interfaces**, your router employs a sync header error counter. (BIP counters aren't supported for 10GE interfaces.)

### What are Bit Error Rate Error States and Thresholds?

BER has the following error conditions for which you must configure threshold values at the interface:

- Signal Degradation (SD): there's a reduction in the signal quality but no loss of service, referred to as 'graceful error'.
- Signal Failure (SF): there's a loss of service because of a link-state change, referred to as 'catastrophic error'. The SF threshold state is enabled by default.

A switch uses the BER threshold value to detect an increased error rate before performance degradation seriously affects traffic. If the polling indicates reaching of the error threshold value:

- For SD BER: the console generates an IOS message.
- For SF BER: the console generates an IOS message. Plus, you can bring down the interface transmission at the device under test (DUT) end.

### Sliding Window for Polling

BER employs the concept of a sliding window to measure bit performance while polling happens in a small-length sequence of several windows. Here, 'window' refers to the BIP period or duration defined for different threshold levels. Consider a scenario where the BIP period is 2.5 seconds and the software polls the hardware counter every 500 ms. In this example, the 2.5 seconds BIP period is complete after five polls, and the window completely deploys. For the next round of polling, the window slides to the following sequence, thus ensuring better error performance while consuming lesser memory.

### Alarm Raise

If errors above the configured threshold accumulate in the first poll, an alarm is raised right away instead of waiting for the completion of the BIP period. For example, if there are errors above the threshold value in the

first poll of 500 ms, an alarm is raised immediately and not after completing 2.5 seconds (five polls) of the BIP period.

### Alarm Clearance

The SD and SF alarm clearance is automatic once the error value is below a certain threshold level. Your router uses the configured error threshold value to measure the errors and generates IOS messages at that threshold.

Your router waits till the last poll of window deployment before clearing the alarm. The alarm is cleared as soon as the error value goes below the configured threshold value. This ensures that no new errors accumulate during the last poll of the completed window, which might keep the error count above the threshold.

### Configure BER

To configure BER thresholds:

1. Enter the configuration mode for your interface.
2. Enable the Signal Degrade Bit Error Rate (SD-BER) on the interface.



---

**Note** SD-BER is disabled by default.

---

3. Configure the SD-BER threshold.
4. Configure the Signal Fail Bit Error Rate (SF-BER) threshold.



---

**Note** SF-BER is enabled by default.

---

5. Enable remote fault signaling when SF BER is triggered.



---

**Note** Remote signaling for SF BER is disabled by default.

---

```
Router#config
Router(config)#int hundredGigE 0/1/0/17
/*Enable SD-BER*/
Router(config-if)#report sd-ber
/*Configure SD-BER threshold*/
Router(config-if)#threshold sd-ber 12
/*Configure SF-BER threshold*/
Router(config-if)#threshold sf-ber 8
/*Enable remote fault signaling*/
Router(config-if)#signal sf-ber remote-fault
Router(config-if)#commit
Router(config-if)#exit
```

### Running Configuration

```
int hundredGigE 0/1/0/17
!
```

```
report sd-ber
!
threshold sd-ber 12
!
threshold sf-ber 8
!
signal sf-ber remote-fault
!
!
```

### Verification

Run the **show controllers <interface> all** command to verify the BER default value as well as the configured threshold values.

```
BER monitoring:
Signal Degrade: 1e-11 (report-alarm)
Signal Fail: 1e-9 (report-alarm, signal-rf)
Current SD BER: 0
Current SF BER: 0
```

```
BER-SD Threshold: 1e-12
BER-SD Report: Enabled
BER-SF Threshold: 1e-8
BER-SF Report: Not configured (Enabled)
BER-SF Signal Remote Failure: Enabled
```

### Associated Commands

- [report sd-ber](#)
- [report sf-ber disable](#)
- [signal sf-ber remote-fault](#)
- [threshold sd-ber](#)
- [threshold sf-ber](#)

## Configuration Examples for Ethernet OAM

This section provides the following configuration examples:

### Configuration Examples for EOAM Interfaces

This section provides the following configuration examples:

#### Configuring an Ethernet OAM Profile Globally: Example

This example shows how to configure an Ethernet OAM profile globally:

```
configure terminal
ethernet oam profile Profile_1
  link-monitor
  symbol-period window 60000
  symbol-period threshold ppm low 10000000 high 60000000
```

```

frame window 60
frame threshold ppm low 10000000 high 60000000
frame-period window 60000
frame-period threshold ppm low 100 high 12000000
frame-seconds window 900000
frame-seconds threshold low 3 high 900
exit
mib-retrieval
connection timeout 30
require-remote mode active
require-remote mib-retrieval
action dying-gasp error-disable-interface
action critical-event error-disable-interface
action discovery-timeout error-disable-interface
action session-down error-disable-interface
action capabilities-conflict error-disable-interface
action wiring-conflict error-disable-interface
action remote-loopback error-disable-interface
commit

```

## Configuring Ethernet OAM Features on an Individual Interface: Example

This example shows how to configure Ethernet OAM features on an individual interface:

```

configure terminal
interface TenGigE 0/1/0/0
  ethernet oam
  link-monitor
  symbol-period window 60000
  symbol-period threshold ppm low 10000000 high 60000000
  frame window 60
  frame threshold ppm low 10000000 high 60000000
  frame-period window 60000
  frame-period threshold ppm low 100 high 12000000
  frame-seconds window 900000
  frame-seconds threshold low 3 high 900
  exit
mib-retrieval
connection timeout 30
require-remote mode active
require-remote mib-retrieval
action link-fault error-disable-interface
action dying-gasp error-disable-interface
action critical-event error-disable-interface
action discovery-timeout error-disable-interface
action session-down error-disable-interface
action capabilities-conflict error-disable-interface
action wiring-conflict error-disable-interface
action remote-loopback error-disable-interface
commit

```

## Configuring Ethernet OAM Features to Override the Profile on an Individual Interface: Example

This example shows the configuration of Ethernet OAM features in a profile followed by an override of that configuration on an interface:

```

configure terminal
ethernet oam profile Profile_1
  mode passive
  action dying-gasp disable
  action critical-event disable

```



```
action discovery-timeout disable
action session-up disable
action session-down disable
action capabilities-conflict disable
action wiring-conflict disable
action remote-loopback disable
action uni-directional link-fault error-disable-interface
commit

configure terminal
interface TenGigE 0/1/0/0
  ethernet oam
  profile Profile_1
  mode active
  action dying-gasp log
  action critical-event log
  action discovery-timeout log
  action session-up log
  action session-down log
  action capabilities-conflict log
  action wiring-conflict log
  action remote-loopback log
  action uni-directional link-fault log
  uni-directional link-fault detection
commit
```

## Clearing Ethernet OAM Statistics on an Interface: Example

This example shows how to clear Ethernet OAM statistics on an interface:

```
RP/0/RP0/CPU0:router# clear ethernet oam statistics interface gigabitethernet 0/1/5/1
```

## Enabling SNMP Server Traps on a Router: Example

This example shows how to enable SNMP server traps on a router:

```
configure terminal
snmp-server traps ethernet oam events
```

## Configuration Examples for Ethernet CFM

This section includes the following examples:

### Ethernet CFM Domain Configuration: Example

This example shows how to configure a basic domain for Ethernet CFM:

```
configure
ethernet cfm
  traceroute cache hold-time 1 size 3000
  domain Domain_One level 1 id string D1
commit
```

### Ethernet CFM Service Configuration: Example

This example shows how to create a service for an Ethernet CFM domain:

```

service Bridge_Service bridge group BD1 bridge-domain B1
service Cross_Connect_1 xconnect group XG1 p2p X1
commit

```

## Flexible Tagging for an Ethernet CFM Service Configuration: Example

This example shows how to set the number of tags in CFM packets from down MEPs in a CFM domain service:

```

configure
 ethernet cfm
  domain D1 level 1
    service S2 bridge group BG1 bridge-domain BD2
    tags 1
  commit

```

## Continuity Check for an Ethernet CFM Service Configuration: Example

This example shows how to configure continuity-check options for an Ethernet CFM service:

```

continuity-check archive hold-time 100
continuity-check loss auto-traceroute
continuity-check interval 100ms loss-threshold 10
commit

```

## MIP Creation for an Ethernet CFM Service Configuration: Example

This example shows how to enable MIP auto-creation for an Ethernet CFM service:

```

RP/0/RP0/CPU0:router(config-cfm-dmn-svc)# mip auto-create all
RP/0/RP0/CPU0:router(config-cfm-dmn-svc)# commit

```

## Cross-check for an Ethernet CFM Service Configuration: Example

This example shows how to configure cross-check for MEPs in an Ethernet CFM service:

```

mep crosscheck
 mep-id 10
 mep-id 20
 commit

```

## Other Ethernet CFM Service Parameter Configuration: Example

This example shows how to configure other Ethernet CFM service options:

```

maximum-meps 4000
log continuity-check errors
commit
exit
exit
exit

```

## MEP Configuration: Example

This example shows how to configure a MEP for Ethernet CFM on an interface:

```
interface TenGigE 0/0/0/1
  ethernet cfm
  mep domain Dm1 service Sv1 mep-id 1
  commit
```

## Ethernet CFM Show Command: Examples

These examples show how to verify the configuration of Ethernet Connectivity Fault Management (CFM):

### Example 1

This example shows how to display all the maintenance points that have been created on an interface:

```
RP/0/RP0/CPU0:router# show ethernet cfm local maintenance-points
```

| Domain/Level | Service | Interface   | Type   | ID | MAC       |
|--------------|---------|-------------|--------|----|-----------|
| fig/5        | bay     | Gi0/10/0/12 | Dn MEP | 2  | 44:55:66  |
| fig/5        | bay     | Gi0/0/1/0   | MIP    |    | 55:66:77  |
| fred/3       | barney  | Gi0/1/0/0   | Dn MEP | 5  | 66:77:88! |

### Example 2

This example shows how to display all the CFM configuration errors on all domains:

```
RP/0/RP0/CPU0:router# show ethernet cfm configuration-errors
```

```
Domain fig (level 5), Service bay
* MIP creation configured using bridge-domain blort, but bridge-domain blort does not exist.

* An Up MEP is configured for this domain on interface TenGigE0/0/0/3 and an Up MEP is
also configured for domain blort, which is at the same level (5).
* A MEP is configured on interface TenGigE0/0/0/1 for this domain/service, which has CC
interval 100ms, but the lowest interval supported on that interface is 1s
```

### Example 3

This example shows how to display operational state for local maintenance end points (MEPs):

```
RP/0/RP0/CPU0:router# show ethernet cfm local meps
```

```
A - AIS received           I - Wrong interval
R - Remote Defect received V - Wrong Level
L - Loop (our MAC received) T - Timed out (archived)
C - Config (our ID received) M - Missing (cross-check)
X - Cross-connect (wrong MAID) U - Unexpected (cross-check)
P - Peer port down
```

```
Domain foo (level 6), Service bar
  ID Interface (State)      Dir MEPs/Err RD Defects AIS
-----
  100 Gi1/1/0/1 (Up)        Up    0/0   N  A    L7

Domain fred (level 5), Service barney
  ID Interface (State)      Dir MEPs/Err RD Defects AIS
-----
  2 Gi0/1/0/0 (Up)         Up    3/2   Y  RPC  L6
Domain foo (level 6), Service bar
```

```

      ID Interface (State)          Dir MEPS/Err RD Defects AIS
-----
100 Gi1/1/0/1 (Up)              Up    0/0   N   A

Domain fred (level 5), Service barney
      ID Interface (State)          Dir MEPS/Err RD Defects AIS
-----
  2 Gi0/1/0/0 (Up)              Up    3/2   Y  RPC

```

#### Example 4

This example shows how to display operational state of other maintenance end points (MEPs) detected by a local MEP:

```
RP/0/RP0/CPU0:router# show ethernet cfm peer meps
```

Flags:

```

> - Ok                      I - Wrong interval
R - Remote Defect received  V - Wrong level
L - Loop (our MAC received) T - Timed out
C - Config (our ID received) M - Missing (cross-check)
X - Cross-connect (wrong MAID) U - Unexpected (cross-check)

```

```
Domain fred (level 7), Service barney
Down MEP on TenGigE0/0/0/1, MEP-ID 2
```

```

=====
St   ID MAC address      Port    Up/Downtime    CcmRcvd SeqErr   RDI Error
---
>   1 0011.2233.4455 Up      00:00:01      1234    0    0    0
R>  4 4455.6677.8899 Up      1d 03:04      3456    0   234  0
L   2 1122.3344.5566 Up      3w 1d 6h      3254    0    0   3254
C   2 7788.9900.1122 Test    00:13         2345    6    20  2345
X   3 2233.4455.6677 Up      00:23         30     0    0    30
I   3 3344.5566.7788 Down    00:34         12345   0    300 1234
V   3 8899.0011.2233 Blocked 00:35         45     0    0    45
T   5 5566.7788.9900      00:56         20     0    0    0
M   6                                0     0    0    0
U>  7 6677.8899.0011 Up      00:02         456    0    0    0

```

```
Domain fred (level 7), Service fig
Down MEP on TenGigE0/0/0/12, MEP-ID 3
```

```

=====
St   ID MAC address      Port    Up/Downtime    CcmRcvd SeqErr   RDI Error
---
>   1 9900.1122.3344 Up      03:45         4321    0    0    0

```

#### Example 5

This example shows how to display operational state of other maintenance end points (MEPs) detected by a local MEP with details:

```
RP/0/RP0/CPU0:router# show ethernet cfm peer meps detail
```

```
Domain dom3 (level 5), Service ser3
Down MEP on TenGigE0/0/0/1 MEP-ID 1
```

```

=====
Peer MEP-ID 10, MAC 0001.0203.0403
CFM state: Wrong level, for 00:01:34
Port state: Up
CCM defects detected:      V - Wrong Level
CCMs received: 5
Out-of-sequence:          0

```

```

Remote Defect received:      5
Wrong Level:                0
Cross-connect (wrong MAID): 0
Wrong Interval:             5
Loop (our MAC received):    0
Config (our ID received):   0
Last CCM received 00:00:06 ago:
Level: 4, Version: 0, Interval: 1min
Sequence number: 5, MEP-ID: 10
MAID: String: dom3, String: ser3
Port status: Up, Interface status: Up

Domain dom4 (level 2), Service ser4
Down MEP on TenGigE0/0/0/2 MEP-ID 1
=====
Peer MEP-ID 20, MAC 0001.0203.0402
CFM state: Ok, for 00:00:04
Port state: Up
CCMs received: 7
  Out-of-sequence:          1
  Remote Defect received:   0
  Wrong Level:              0
  Cross-connect (wrong MAID): 0
  Wrong Interval:          0
  Loop (our MAC received):  0
  Config (our ID received): 0
Last CCM received 00:00:04 ago:
Level: 2, Version: 0, Interval: 10s
Sequence number: 1, MEP-ID: 20
MAID: String: dom4, String: ser4
Chassis ID: Local: ios; Management address: 'Not specified'
Port status: Up, Interface status: Up

Peer MEP-ID 21, MAC 0001.0203.0403
CFM state: Ok, for 00:00:05
Port state: Up
CCMs received: 6
  Out-of-sequence:          0
  Remote Defect received:   0
  Wrong Level:              0
  Cross-connect (wrong MAID): 0
  Wrong Interval:          0
  Loop (our MAC received):  0
  Config (our ID received): 0
Last CCM received 00:00:05 ago:
Level: 2, Version: 0, Interval: 10s
Sequence number: 1, MEP-ID: 21
MAID: String: dom4, String: ser4
Port status: Up, Interface status: Up

Peer MEP-ID 601, MAC 0001.0203.0402
CFM state: Timed Out (Standby), for 00:15:14, RDI received
Port state: Down
CCM defects detected:      Defects below ignored on local standby MEP
                           I - Wrong Interval
                           R - Remote Defect received
                           T - Timed Out
                           P - Peer port down

CCMs received: 2
  Out-of-sequence:          0
  Remote Defect received:   2
  Wrong Level:              0

```

```

Wrong Interval:          2
Loop (our MAC received): 0
Config (our ID received): 0
Last CCM received 00:15:49 ago:
Level: 2, Version: 0, Interval: 10s
Sequence number: 1, MEP-ID: 600
MAID: DNS-like: dom5, String: ser5
Chassis ID: Local: ios; Management address: 'Not specified'
Port status: Up, Interface status: Down

```

## Ethernet CFM Show Command for flexible packet format: Examples

The flexible packet format supports the following two types of formats:

- MDID String format
- MDID Invalid format



---

**Note** To enable the feature in native mode, use the **hw-module profile oam 48byte-cfm-maid-enable** command in the System Admin Config mode. Ensure that you reload the router after configuring the native mode.

---

```

Router(config)#hw-module profile oam ?
  48byte-cfm-maid-enable  Enable 48byte cfm maid feature
  sat-enable              enable SAT feature
Router(config)#hw-module profile oam 48byte-cfm-maid-enable
In order to make the oam profile take effect, the router must be manually reloaded.
Router(config)#commit

Router(config)#hw-module profile npu native-mode-enable
Tue Nov 16 06:48:34.027 UTC
In order to activate this new npu profile, you must manually reload the chassis
Router(config)#commit

```

### MDID String format: Example

#### Configuration

```

Router(config)#ethernet cfm
Router(config-cfm)#domain test level 3 id string test_domain
Router(config-cfm-dmn)#service test down-meps id string test_service
Router(config-cfm-dmn-svc)#mep crosscheck mep-id 4
Router(config-cfm-dmn-svc)#log continuity-check mep changes
Router(config-cfm-dmn-svc)#continuity-check interval 10ms
Router(config-cfm-dmn-svc)#commit
Router(config-cfm-dmn-svc)#root
Router(config)#interface TenGigE0/0/0/0.1 12tr

Router(config-subif)#encapsulation dot1q 1

Router(config-subif)#ethernet cfm
Router(config-if-cfm)#mep domain test service test mep-id 3
Router(config-if-cfm-mep)#commit

```

**Verification**

```
Router#show ethernet cfm peer meps
```

```
Tue Nov 16 06:46:13.859 UTC
Flags:
> - Ok                               I - Wrong interval
R - Remote Defect received           V - Wrong level
L - Loop (our MAC received)         T - Timed out
C - Config (our ID received)        M - Missing (cross-check)
X - Cross-connect (wrong MAID)      U - Unexpected (cross-check)
* - Multiple errors received         S - Standby
```

```
Domain test (level 3), Service test
Down MEP on TenGigE0/0/0/0.1 MEP-ID 3
```

```
=====
St   ID MAC Address   Port   Up/Downtime   CcmRcvd SeqErr   RDI Error
---  ---
>   4 d46a.355c.b814 Up     00:02:30     0      0      0      0
```

```
Router#show ethernet cfm peer meps detail
```

```
Tue Nov 16 06:46:29.169 UTC
Domain test (level 3), Service test
Down MEP on TenGigE0/0/0/0.1 MEP-ID 3
```

```
=====
Peer MEP-ID 4, MAC d46a.355c.b814
CFM state: Ok, for 00:02:46
Received CCM handling offloaded to hardware
Port state: Up
CCMs received: 0
  Out-of-sequence:          0
  Remote Defect received:   0
  Wrong level:              0
  Cross-connect (wrong MAID): 0
  Wrong interval:          0
  Loop (our MAC received):  0
  Config (our ID received): 0
Last CCM received:
  Level: 3, Version: 0, Interval: 10ms
  Sequence number: 0, MEP-ID: 4
  MAID: String: test_domain, String: test_service
  Port status: Up, Interface status: Up
```

```
Router#show ethernet cfm local meps verbose
```

```
Tue Nov 16 06:46:41.783 UTC
Domain test (level 3), Service test
Down MEP on TenGigE0/0/0/0.1 MEP-ID 3
=====
Interface state: Up      MAC address: b0c5.3cff.c080
Peer MEPs: 1 up, 0 with errors, 0 timed out (archived)
Cross-check errors: 0 missing, 0 unexpected

CCM generation enabled: Yes, 10ms (Remote Defect detected: No)
                        CCM processing offloaded to hardware
AIS generation enabled: No
Sending AIS:            No
Receiving AIS:         No
Sending CSF:           No
Receiving CSF:         No

No packets sent/received
```

```
Router#
```

## MDID Invalid format: Example

```

Router#show run interface tenGigE 0/0/0/0.1
Tue Nov 16 06:47:09.035 UTC
interface TenGigE0/0/0/0.1 l2transport
encapsulation dot1q 1
ethernet cfm
  mep domain test service test mep-id 3
  !
  !
  !

Router#show run ethernet cfm
Tue Nov 16 06:47:23.800 UTC
ethernet cfm
domain test level 3 id string test_domain
  service test down-meps id string test_service
  continuity-check interval 10ms
  mep crosscheck
  mep-id 4
  !
  log continuity-check mep changes
  !
  !
  !
-----

```

## MDID Invalid format: Example

## Configuration

```

Router#show run ethernet cfm
Tue Nov 16 06:57:14.099 UTC

ethernet cfm
domain test level 3
  service test down-meps
  continuity-check interval 10ms
  mep crosscheck
  mep-id 4
  !
  log continuity-check mep changes
  !
  !
  !

```

## Verification

```

Router#show ethernet cfm peer meps
Tue Nov 16 06:57:19.027 UTC
Flags:
> - Ok                               I - Wrong interval
R - Remote Defect received           V - Wrong level
L - Loop (our MAC received)          T - Timed out
C - Config (our ID received)         M - Missing (cross-check)
X - Cross-connect (wrong MAID)       U - Unexpected (cross-check)
* - Multiple errors received         S - Standby

```

```

Domain test (level 3), Service test
Down MEP on TenGigE0/0/0/0.1 MEP-ID 3

```

```

=====
St   ID MAC Address      Port    Up/DownTime    CcmRcvd SeqErr    RDI Error
--   -
>   4 d46a.355c.b814 Up      00:00:24      0        0        0        0

```



```
Router#show ethernet cfm peer meps detail
```

```
Tue Nov 16 06:57:23.567 UTC
Domain test (level 3), Service test
Down MEP on TenGigE0/0/0/0.1 MEP-ID 3
```

```
=====
Peer MEP-ID 4, MAC d46a.355c.b814
  CFM state: Ok, for 00:00:29
  Received CCM handling offloaded to hardware
  Port state: Up
  CCMs received: 0
    Out-of-sequence:          0
    Remote Defect received:    0
    Wrong level:              0
    Cross-connect (wrong MAID): 0
    Wrong interval:           0
    Loop (our MAC received):   0
    Config (our ID received):  0
  Last CCM received:
    Level: 3, Version: 0, Interval: 10ms
    Sequence number: 0, MEP-ID: 4
    MAID: String: test, String: test
    Port status: Up, Interface status: Up
```

```
Router#show ethernet cfm local meps
```

```
Tue Nov 16 06:57:36.672 UTC
Defects (from at least one peer MEP):
A - AIS received           I - Wrong interval
R - Remote Defect received V - Wrong level
L - Loop (our MAC received) T - Timed out
C - Config (our ID received) M - Missing (cross-check)
X - Cross-connect (wrong MAID) U - Unexpected (cross-check)
P - Peer port down        F - CSF received
```

```
Domain test (level 3), Service test
  ID Interface (State)      Dir MEPs/Err RD Defects AIS
-----
  3 Te0/0/0/0.1 (Up)      Dn      1/0  N
```

```
Router#show ethernet cfm local meps verbose
```

```
Tue Nov 16 06:57:39.015 UTC
Domain test (level 3), Service test
Down MEP on TenGigE0/0/0/0.1 MEP-ID 3
=====
Interface state: Up      MAC address: b0c5.3cff.c080
Peer MEPs: 1 up, 0 with errors, 0 timed out (archived)
Cross-check errors: 0 missing, 0 unexpected

CCM generation enabled: Yes, 10ms (Remote Defect detected: No)
                        CCM processing offloaded to hardware
AIS generation enabled: No
Sending AIS:           No
Receiving AIS:         No
Sending CSF:           No
Receiving CSF:         No

No packets sent/received
Router#
```

## AIS for CFM Configuration: Examples

### Example 1

This example shows how to configure Alarm Indication Signal (AIS) transmission for a CFM domain service:

```
RP/0/RP0/CPU0:router# configure
RP/0/RP0/CPU0:router(config)# ethernet cfm
RP/0/RP0/CPU0:router(config-cfm)# domain D1 level 1
RP/0/RP0/CPU0:router(config-cfm-dmn)# service S1 bridge group BG1 bridge-domain BD2
RP/0/RP0/CPU0:router(config-cfm-dmn-svc)# ais transmission interval 1m cos 7

RP/0/RP0/CPU0:router# configure
RP/0/RP0/CPU0:router(config)# ethernet cfm
RP/0/RP0/CPU0:router(config-cfm)# domain D1 level 1
RP/0/RP0/CPU0:router(config-cfm-dmn)# service Cross_Connect_1 xconnect group XG1 p2p X1
RP/0/RP0/CPU0:router(config-cfm-dmn-svc)# ais transmission interval 1m cos 7
```

### Example 2

This example shows how to configure AIS logging for a Connectivity Fault Management (CFM) domain service to indicate when AIS or LCK packets are received:

```
RP/0/RP0/CPU0:router# configure
RP/0/RP0/CPU0:router(config)# ethernet cfm
RP/0/RP0/CPU0:router(config-cfm)# domain D1 level 1
RP/0/RP0/CPU0:router(config-cfm-dmn)# service S2 bridge group BG1 bridge-domain BD2
RP/0/RP0/CPU0:router(config-cfm-dmn-svc)# log ais

RP/0/RP0/CPU0:router# configure
RP/0/RP0/CPU0:router(config)# ethernet cfm
RP/0/RP0/CPU0:router(config-cfm)# domain D1 level 1
RP/0/RP0/CPU0:router(config-cfm-dmn)# service Cross_Connect_1 xconnect group XG1 p2p X1
RP/0/RP0/CPU0:router(config-cfm-dmn-svc)# log ais
```

This example shows how to configure AIS transmission on a CFM interface.

```
RP/0/RP0/CPU0:router# configure
RP/0/RP0/CPU0:router(config)# interface TenGigE 0/1/0/2
RP/0/RP0/CPU0:router(config-if)# ethernet cfm
RP/0/RP0/CPU0:router(config-if-cfm)# ais transmission up interval 1m cos 7
```

## AIS for CFM Show Commands: Examples

This section includes the following examples:

### show ethernet cfm interfaces ais Command: Example

This example shows how to display the information published in the Interface AIS table:

```
RP/0/RP0/CPU0:router# show ethernet cfm interfaces ais

Defects (from at least one peer MEP):
A - AIS received           I - Wrong interval
R - Remote Defect received V - Wrong Level
L - Loop (our MAC received) T - Timed out (archived)
C - Config (our ID received) M - Missing (cross-check)
```

X - Cross-connect (wrong MAID) U - Unexpected (cross-check)  
 P - Peer port down D - Local port down

| Interface (State)   | AIS Dir | Trigger |         | Via Levels | Transmission |     |              |         |
|---------------------|---------|---------|---------|------------|--------------|-----|--------------|---------|
|                     |         | L       | Defects |            | L            | Int | Last started | Packets |
| TenGigE0/0/0/0 (Up) | Dn      | 5       | RPC     | 6          | 7            | 1s  | 01:32:56 ago | 5576    |
| TenGigE0/0/0/0 (Up) | Up      | 0       | M       | 2,3        | 5            | 1s  | 00:16:23 ago | 983     |
| TenGigE0/0/0/1 (Dn) | Up      |         | D       |            | 7            | 60s | 01:02:44 ago | 3764    |
| TenGigE0/0/0/2 (Up) | Dn      | 0       | RX      | 1!         |              |     |              |         |

## show ethernet cfm local meps Command: Examples

### Example 1: Default

This example shows how to display statistics for local maintenance end points (MEPs):

```
RP/0/RP0/CPU0:router# show ethernet cfm local meps
```

A - AIS received I - Wrong interval  
 R - Remote Defect received V - Wrong Level  
 L - Loop (our MAC received) T - Timed out (archived)  
 C - Config (our ID received) M - Missing (cross-check)  
 X - Cross-connect (wrong MAID) U - Unexpected (cross-check)  
 P - Peer port down

```
Domain foo (level 6), Service bar
  ID Interface (State) Dir MEPS/Err RD Defects AIS
-----
  100 Gi1/1/0/1 (Up) Up 0/0 N A 7
```

```
Domain fred (level 5), Service barney
  ID Interface (State) Dir MEPS/Err RD Defects AIS
-----
  2 Gi0/1/0/0 (Up) Up 3/2 Y RPC 6
```

### Example 2: Domain Service

This example shows how to display statistics for MEPs in a domain service:

```
RP/0/RP0/CPU0:router# show ethernet cfm local meps domain foo service bar detail
```

```
Domain foo (level 6), Service bar
Down MEP on TenGigE0/0/0/1, MEP-ID 100
=====
Interface state: Up MAC address: 1122.3344.5566
Peer MEPS: 0 up, 0 with errors, 0 timed out (archived)

CCM generation enabled: No
AIS generation enabled: Yes (level: 7, interval: 1s)
Sending AIS: Yes (started 01:32:56 ago)
Receiving AIS: Yes (from lower MEP, started 01:32:56 ago)

Domain fred (level 5), Service barney
Down MEP on TenGigE0/0/0/1, MEP-ID 2
=====
Interface state: Up MAC address: 1122.3344.5566
Peer MEPS: 3 up, 2 with errors, 0 timed out (archived)
Cross-check defects: 0 missing, 0 unexpected
```

**show ethernet cfm local meps detail Command: Example**

```

CCM generation enabled: Yes (Remote Defect detected: Yes)
CCM defects detected:  R - Remote Defect received
                       P - Peer port down
                       C - Config (our ID received)
AIS generation enabled: Yes (level: 6, interval: 1s)
Sending AIS:           Yes (to higher MEP, started 01:32:56 ago)
Receiving AIS:         No

```

**Example 4: Detail**

This example shows how to display detailed statistics for MEPs in a domain service:

```

RP/0/RP0/CPU0:router# show ethernet cfm local meps detail

Domain foo (level 6), Service bar
Down MEP on TenGigE0/0/0/1, MEP-ID 100
=====
Interface state: Up      MAC address: 1122.3344.5566
Peer MEPs: 0 up, 0 with errors, 0 timed out (archived)

CCM generation enabled: No
AIS generation enabled: Yes (level: 7, interval: 1s)
Sending AIS:           Yes (started 01:32:56 ago)
Receiving AIS:         Yes (from lower MEP, started 01:32:56 ago)

Domain fred (level 5), Service barney
Down MEP on TenGigE0/0/0/1, MEP-ID 2
=====
Interface state: Up      MAC address: 1122.3344.5566
Peer MEPs: 3 up, 2 with errors, 0 timed out (archived)
Cross-check defects: 0 missing, 0 unexpected

CCM generation enabled: Yes (Remote Defect detected: Yes)
CCM defects detected:  R - Remote Defect received
                       P - Peer port down
                       C - Config (our ID received)
AIS generation enabled: Yes (level: 6, interval: 1s)
Sending AIS:           Yes (to higher MEP, started 01:32:56 ago)
Receiving AIS:         No

```

**show ethernet cfm local meps detail Command: Example**

Use the **show ethernet cfm local meps detail** command to display MEP-related EFD status information. This example shows that EFD is triggered for MEP-ID 100:

```

RP/0/RP0/CPU0:router# show ethernet cfm local meps detail

Domain foo (level 6), Service bar
Down MEP on TenGigE0/0/0/1, MEP-ID 100
=====
Interface state: Up      MAC address: 1122.3344.5566
Peer MEPs: 0 up, 0 with errors, 0 timed out (archived)
Cross-check errors: 2 missing, 0 unexpected

CCM generation enabled: No
AIS generation enabled: Yes (level: 7, interval: 1s)
Sending AIS:           Yes (started 01:32:56 ago)
Receiving AIS:         Yes (from lower MEP, started 01:32:56 ago)
EFD triggered:         Yes

Domain fred (level 5), Service barney

```

```
Down MEP on TenGigE0/0/0/1, MEP-ID 2
```

```
=====
Interface state: Up      MAC address: 1122.3344.5566
Peer MEPs: 3 up, 0 with errors, 0 timed out (archived)
Cross-check errors: 0 missing, 0 unexpected

CCM generation enabled: Yes (Remote Defect detected: No)
AIS generation enabled: Yes (level: 6, interval: 1s)
Sending AIS:            No
Receiving AIS:          No
EFD triggered:          No
```



**Note** You can also verify that EFD has been triggered on an interface using the **show interfaces** and **show interfaces brief** commands. When an EFD trigger has occurred, these commands will show the interface status as *up* and the line protocol state as *down*.

## CFM Adaptive Bandwidth Notifications

Microwave links are used in carrier ethernet networks, because they are cheaper than laying fibre either in dense metro areas or rural locations. However, the disadvantage of microwave links is that the signal is affected by atmospheric conditions and can degrade.

Modern microwave devices support adaptive modulation schemes to prevent a complete loss of signal. This allows them to continue to operate during periods of degradation, but at a reduced bandwidth. However, to fully take advantage of this, it's necessary to convey the decrease in bandwidth to the head-end router so that appropriate actions can be taken. Otherwise, the link may become saturated and traffic dropped arbitrarily as shown in the following figure:

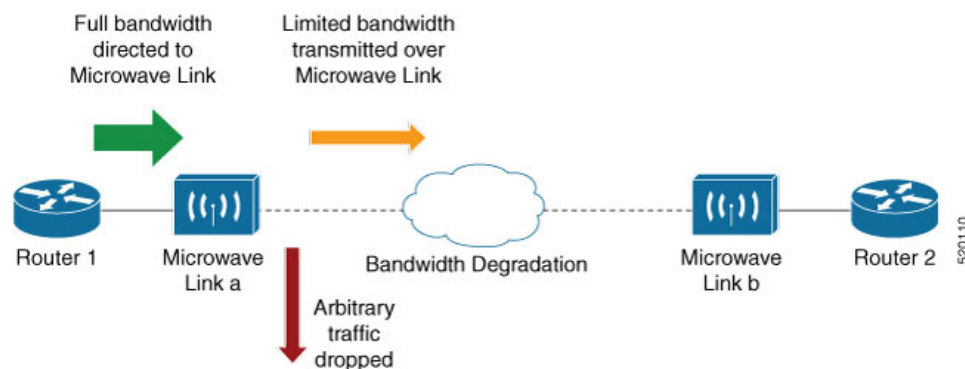

A generic solution to this is a Connectivity Fault Management (CFM) extension to send Bandwidth Notifications Messages (BNM) to Maintenance Endpoints (MEPs) on the corresponding interface on the head-end router. To be flexible in the actions taken, the choice of solution uses Embedded Event Manager (EEM) to invoke operator written TCL scripts. For information on EEM, see [Embedded Event Manager, on page 89](#).

## Bandwidth Notification Messages

The two types of messages used to notify the head-end router are:

- G.8013 Bandwidth Notification Messages (G.8013 BNM)

- Cisco proprietary Bandwidth Vendor-Specific Messages (Cisco BW-VSM)

Both the message types contain the following information:

- Source MAC
- Port ID
- Maintenance Domain (MD) Level
- Transmission period
- Nominal Bandwidth
- Current Bandwidth

During signal degradation, periodic BNMs are sent to the head-end router containing the current bandwidth (sampled over a period of time) and nominal bandwidth (full bandwidth when there is no degradation). This allows the router to reduce the bandwidth directed to the link as shown in the figure below:

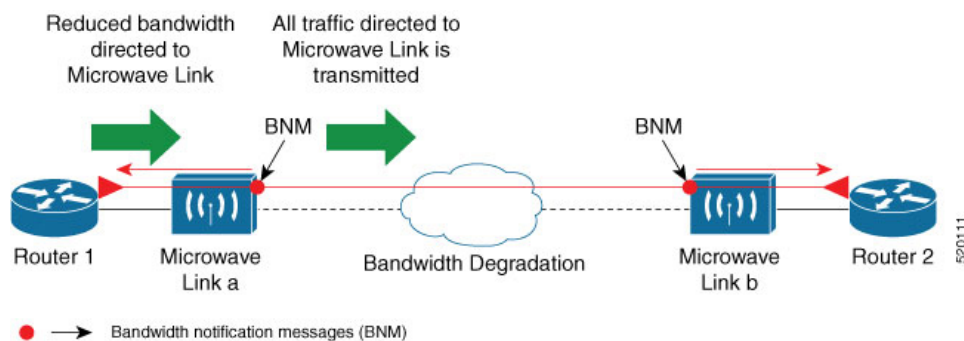

When degradation in bandwidth is detected, depending on the topology, the degradation may affect one or more paths in the network. Therefore, in more complex topologies, the head-end router may need information about links in each affected path. The BNM transmission period and a Link ID are used to differentiate between messages from the same source MAC address which refer to different links.

## Restrictions for CFM Bandwidth Notifications

The list of restrictions for CFM Bandwidth Notifications is:

- Up to 200 unique BNM enabled links learnt from BNMs are supported per line card. Any BNMs for links over this limit will be discarded.

To reset CFM BNM enabled links for the specified interfaces, use the `clear ethernet cfm interface [ <interface> ] bandwidth-notifications { all | state <state> } [ location { all | <node> } ]` command. An archive timer is used to clean up any BNM enabled links whose loss timer expired at least 24 hours ago.

- Over process restart:
  - Loss threshold, wait-to-restore, and hold-off timers are restarted. This may cause links to take longer to transition between states than they would have otherwise.
  - Archive timers are restarted. This may cause historical statistics for links to persist longer than they would have otherwise.

- Queued events for EEM scripts which have been rate-limited are not preserved. Scripts with at least one link in DEGRADED state, or BNM's have changed over process restart, and are invoked. Rate-limit timers are restarted. This may cause scripts to be invoked when they would otherwise have been filtered by the damping or conformance-testing algorithms. If the last link returns to its nominal bandwidth within the rate-limit period but before the process restart, then the script will not be invoked after the process restart. Thus, actions taken by the script may not reflect the (increased) latest bandwidths of any links which returned to their nominal bandwidths within the rate-limit period.

## Bandwidth Reporting

Received BNM's are used to identify BNM enabled links within a Maintenance Entity Group (MEG), and should be uniquely identifiable within the MEG by Port-ID or MAC address. Each link has an associated nominal bandwidth, and a Reported Bandwidth (RBW), which are notified to the operator. The link is considered to be in OK state when the RBW is equal to the nominal bandwidth and DEGRADED if RBW is less than nominal.

Devices sending BNM's can detect changes in bandwidth many times a second. For example, changes caused by an object passing through a microwave link's line of sight. The protocol for sending BNM's is designed to mitigate fluctuating current bandwidth by sampling across a 'monitoring-interval' and applying basic damping to degradation events. To help mitigate this further, a damping algorithm is used. This algorithm is applied on the receiving device, and is distinct from any damping performed by the sender. For more information on this, see [Damping Algorithm, on page 88](#).

An operator may be interested in more than one BNM enabled link, and needs the ability to register on a set of BNM enabled links which affect the path to a node in the network. To do this, the state and RBW for each link of interest are put into a conformance testing algorithm, which both filters and rate-limits changes to publish events notifying the operator only of significant changes. For more information on this, see [Conformance Testing Algorithm, on page 89](#).

The following diagram shows how a received BNM flows through the damping and conformance testing algorithm to invoke operator scripts:



### Note

- Port ID takes precedence over MAC address. This means that BNM's with same port ID but different MAC addresses are counted as same BNM's.
- If BNM reported bandwidth is equal to the threshold, then EEM will not be invoked.
- If a degraded link having bandwidth higher than the threshold receives BNM with bandwidth less than the threshold, it doesn't wait for the hold-off timer and instantly changes the bandwidth by invoking EEM script.

## Damping Algorithm

A damping algorithm is applied to each unique BNM enabled link for which BNMs are received. The table below describes the timers used for this purpose:

| Timers                             | Description                                                                                                                                                                                                                                                                                                                                                                                                                                                                                                         |
|------------------------------------|---------------------------------------------------------------------------------------------------------------------------------------------------------------------------------------------------------------------------------------------------------------------------------------------------------------------------------------------------------------------------------------------------------------------------------------------------------------------------------------------------------------------|
| loss threshold (in packet numbers) | This timer handles the case when BNMs stop being received. This timer is (re)started whenever any BNM is received for the link. The value is equal to the expected period between BNMs (as indicated by the last BNM) multiplied by the configured loss threshold. When the loss threshold timer expires, as the link may have changed or been removed entirely, bandwidth information is no longer available, therefore the link is considered to have been restored to its previously notified nominal bandwidth. |
| hold-off (in seconds)              | This timer is used to damp transient transitions from OK to DEGRADED state. It is started when the first degraded BNM is received, and is stopped if the loss threshold timer expires or the current bandwidth returns to the nominal bandwidth. If the timer expires, then the BNM enabled link enters DEGRADED state. The value of this timer is configurable. If it is zero, then the link immediately enters degraded state and the timer is not started.                                                       |
| wait-to-restore (WTR, in seconds)  | This timer is used to damp transient transitions from DEGRADED to OK state. It is started when a BNM Enabled Link is in DEGRADED state and either the loss threshold timer expires or a BNM is received that indicates the current bandwidth has returned to the nominal bandwidth. If a degraded BNM is received while the timer is running then it is stopped and the BNM Enabled Link remains in DEGRADED state. If this timer expires then the link returns to OK state.                                        |

The following internal state transition diagram shows how damping algorithm takes place:



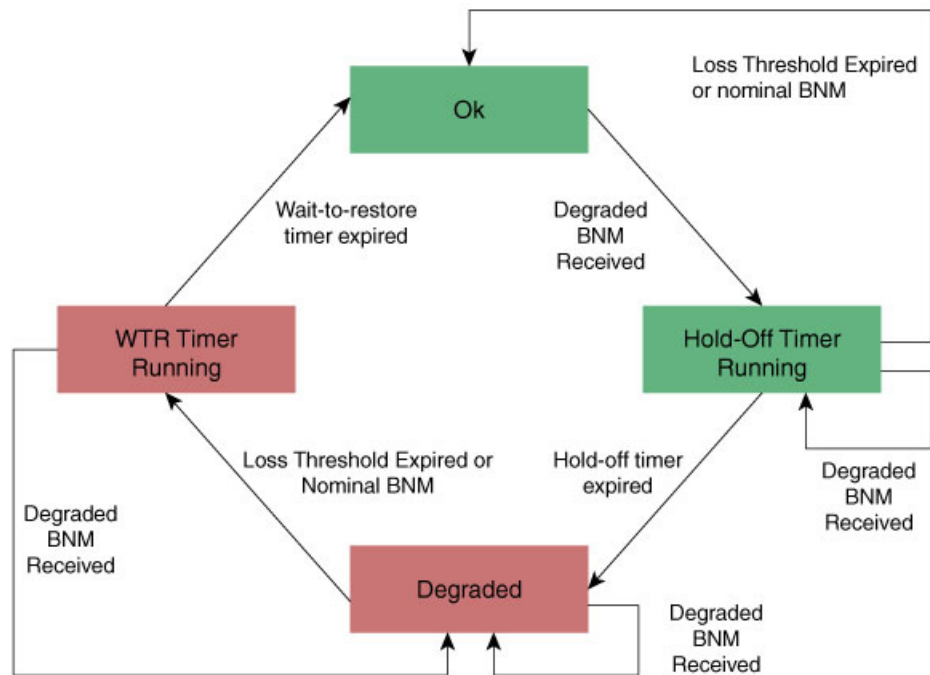

## Conformance Testing Algorithm

The conformance testing algorithm comprises of two parts:

### 1. Filtering bandwidth changes.

Filtering is done so that events are published whenever either:

- Any link which was in OK state or had a RBW more than or equal to the specified threshold, has transitioned to DEGRADED state and has a RBW less than the specified threshold.
- Any link which was in DEGRADED state and had a RBW less than the specified threshold, is still in DEGRADED state and has a RBW less than the specified threshold, but the old and new RBWs are different.
- Any link which was in DEGRADED state and had a RBW less than the specified threshold, has transitioned to OK state or has a RBW more than or equal to the specified threshold.

### 2. Rate-limiting bandwidth changes

Rate-limiting is done by only publishing events at most once within any rate-limit period. If there is a change in bandwidth (which passes the filter) within this rate-limit period, a timer is started to expire at the end of the period. Upon timer expiry, an event is published which reflects the latest state and bandwidth of all links of interest which are in DEGRADED state.

## Embedded Event Manager

The Embedded Event Manager (EEM) consists of an EEM server that monitors various real-time events in the system using programs called Event Detectors (EDs) and triggers registered policies (for example, TCLscripts) to run. The EEM supports at least 200 script registrations.

Typical actions taken in response to signal degradation events include:

- Signaling to G.8032 to switch some flows to alternative paths
- Modifying QoS configuration to adjust traffic shaping to the new bandwidth
- Adjusting IGP metrics to switch some traffic to an alternative path

The following variables can be queried within the TCL script:

| EEM Variables                                              | Comment                                                                                                                                                                                                                                                                                                                                                                                        |
|------------------------------------------------------------|------------------------------------------------------------------------------------------------------------------------------------------------------------------------------------------------------------------------------------------------------------------------------------------------------------------------------------------------------------------------------------------------|
| <code>interface, level, direction</code>                   | Identify the MEP in the registration                                                                                                                                                                                                                                                                                                                                                           |
| <code>min_reported_bandwidth</code>                        | Minimum reported bandwidth across all links in the registration that are currently in DEGRADED state, and below the specified threshold                                                                                                                                                                                                                                                        |
| <code>bnm_enabled_links [{ MAC address   Port ID }]</code> | Array of BNM enabled links, with each one containing the following elements: <ul style="list-style-type: none"> <li>• <code>reported_bw</code>: Reported Bandwidth</li> <li>• <code>nominal_bw</code>: Nominal BW in last BNM</li> </ul>                                                                                                                                                       |
| <code>event_type</code>                                    | Either 'DEGRADED' or 'OK'<br><br>DEGRADED indicates that at least one BNM enabled link in the registration is in DEGRADED state with a reported bandwidth less than the threshold.<br><br>This means that the <code>event_type</code> could be 'OK' if all BNM enabled links in the registration which are in DEGRADED state have a reported bandwidth greater than or equal to the threshold. |

The command for EEM TCL scripts registering for CFM Bandwidth Notification events is `interface <interface name> level <level> direction <direction> {mac-addresses { <addr1> [, ..., <addr20>] } | port-ids { <id1> [, ..., <id20>] } threshold <bandwidth> [ ratelimit <time> ]`.

To configure EEM, use the following commands:

```
event manager directory user policy disk0:/
event manager directory user library disk0:/
event manager policy EEMscript7.tcl username root persist-time 3600
aaa authorization eventmanager default local
```

Individual scripts located in the specified directory can then be configured with:

```
event manager policy <script_name> username lab persist-time <time>
```

## Event Publishing

CFM publishes events for a given EEM registration after applying the damping and conformance testing algorithms as described in [Damping Algorithm, on page 88](#) and [Conformance Testing Algorithm, on page 89](#) respectively. The set of BNM Enabled Links published in an event are those in DEGRADED state and whose RBW is less than the specified threshold.

## Configure CFM Bandwidth Notifications

Use the following steps to configure CFM bandwidth notifications:

- Configure a CFM domain at the level BNMs are expected to be received at, and a CFM service in the direction (either up or down-MEPs) the BNMs are expected to be received.
- Configure a CFM MEP on the interface expected to receive BNMs in the domain and service above.

Configuration consists of two parts:

- Configuring global CFM. This is similar to Continuity Check Message (CCM) and other CFM configurations.

### Global CFM configuration:

```

ethernet cfm
domain DM1 level 2 id null
  service SR1 down-meps
!
!
domain dom1 level 1
  service ser1 down-meps
!
!

```

- Configuration related to CFM-BNMs under interfaces. This is optional and used for changing default values.

### Interface configuration:

```

Interface TenGigE0/0/1/1
ethernet cfm
  mep domain DM1 service SR1 mep-id 3001
!
  bandwidth-notifications
  hold-off 0
  wait-to-restore 60
  loss-threshold 10
  log changes
!
!
l2transport
!
!
interface TenGigE0/0/0/3
ethernet cfm
  mep domain dom1 service ser1 mep-id 11
!
  bandwidth-notifications
  hold-off 10
  wait-to-restore 40
  log changes
!
!
l2transport
!
!

```

### Running Configuration

```

RP/0/RP0/CPU0:router#show running-configuration
!! IOS XR Configuration 7.1.1.104I

```

```

!! Last configuration change at Mon Jun 24 21:26:46 2019 by root
!
hostname R2_cXR
logging console debugging
logging buffered 125000000
event manager directory user policy harddisk:/tcl/
event manager directory user library harddisk:/tcl/
event manager policy EEMmac_levl.tcl username root persist-time 3600
event manager policy EEMport_levl.tcl username root persist-time 3600
aaa authorization exec default local group tacacs+
aaa authorization eventmanager default local
!
ethernet cfm
domain DM0 level 1 id null
  service SR0 down-meps
    continuity-check interval 1m
    mep crosscheck
    mep-id 1003
  !
  ais transmission interval 1s cos 4
  log ais
  log continuity-check errors
  log crosscheck errors
  log continuity-check mep changes
  !
!
domain DM1 level 2 id null
  service SR1 down-meps id number 1
    continuity-check interval 1m
    mep crosscheck
    mep-id 431
  !
  ais transmission interval 1m
  log ais
  log continuity-check errors
  log crosscheck errors
  log continuity-check mep changes
  !
!
domain dom1 level 3 id string domain3
  service ser1 xconnect group XG1 p2p XC1 id number 2300
    mip auto-create all
    continuity-check interval 1m
    mep crosscheck
    mep-id 2030
  !
!
interface Loopback0
  ipv4 address 30.30.30.30 255.255.255.255
!
interface MgmtEth0/RSP0/CPU0/0
  ipv4 address 5.18.9.102 255.255.0.0
!
interface MgmtEth0/RSP0/CPU0/1
  shutdown
!
interface TenGigE0/0/0/0
  shutdown
!
interface TenGigE0/0/0/3.1 12transport
  encapsulation dot1q 6
  ethernet cfm
  mep domain DM1 service SR1 mep-id 231
  !
  bandwidth-notifications
  hold-off 50

```

```

wait-to-restore 50
loss-threshold 100
log changes
!

```

### Verification

```

RP/0/RP0/CPU0:router#show ethernet cfm interfaces bandwidth-notifications detail
BNM Enabled Links at Level 3 (Down MEP) for GigabitEthernet/1
MAC Address 000a.000a.000a
  State (OK):
    Nominal Bandwidth:                3000 Mbps
    Reported Bandwidth:                1000 Mbps
    Elapsed time in this state:        00:00:13.000
    Transitions into degraded state:   5000
    Hold-off:                          111s remaining
  Last BNM received 00:00:10 ago
    Nominal Bandwidth:                1000 Mbps
    Current Bandwidth:                2000 Mbps
    Interval:                          10s
    Packet-type:                       Cisco BW-VSM
    Packets received:                  20000

Port ID 7 (MAC Address 000c.000c.000c)
  State (DEGRADED):
    Nominal Bandwidth:                6000 Mbps
    Reported Bandwidth:                2000 Mbps
    Elapsed time in this state:        00:00:39.000
    Transitions into degraded state:   10000
    Wait-to-restore:                  111s remaining
  Last BNM received 00:00:33 ago
    Nominal Bandwidth:                2000 Mbps
    Current Bandwidth:                4000 Mbps
    Interval:                          1min
    Packet-type:                       Cisco BW-VSM
    Packets received:                  40000

```

## Link Loss Forwarding

The Cisco ASR9000 Series Routers support Link Loss Forwarding (LLF). LLF uses CFM to transmit notification of a signal loss or fault across the network. If a local AC goes down, LLF sends signals across to the neighboring device.

The following packet types indicate a fault in a network:

- Continuity Check Message (CCM). Also known as CFM
- Alarm Indication Signal (AIS)
- Client Signal Frame (CSF)

When the system receives a CCM or AIS with fault indication, or a CSF error packet, CFM communicates with Ether-MA to TX-disable the interface.

Ether-MA handles owner channel communication and resyncs from CFMD, L2VPN, and other Ether-MA processes.

## Restrictions for LLF

- LLF isn't permitted on sub-interfaces.
- LLF is only permitted on up MEPs.
- The system runs a damping timer to govern transitions from an interface being TX-disabled to an interface being TX-enabled. The following restrictions apply on such a scenario:
  - The period of the damping timer is given by three times the configured CCM interval. However, you can't configure the damping timer.
  - The system doesn't provide damping for transitions from TX-enabled to TX-disabled.

## Configure Link Loss Forwarding

This section describes how to configure LLF on a network by using the `propagate-remote-status` config command.

```
/* Enable LLF */
RP/0/RP0/CPU0:router# configure
RP/0/RP0/CPU0:router(config)# interface GigabitEthernet0/2/0/0
RP/0/RP0/CPU0:router(config-cfm)# ethernet cfm
RP/0/RP0/CPU0:router(config-cfm)# mep domain foo service bar mep-id 1
RP/0/RP0/CPU0:router(config-cfm)# propagate remote-status
RP/0/RP0/CPU0:router(config-cfm)# commit
```

### Optional Configuration for Client Signal Fail (CSF)



**Note** CSF configuration is required for inter-operation with certain client-end setups that contain devices from other clients.

```
ethernet cfm
  domain <domain> level <level> service <service> <type>
  csf [<interval> {1s | 1m}] [cos <cos>]
  log csf
```

### Running Configuration

```
ethernet cfm
  domain dom1 level 1
  service ser1 bridge group up-meps bridge-domain up-mep
  continuity-check interval 1m
  csf interval 1m cos 4
  csf-logging
  !
  !
  !
interface GigabitEthernet0/2/0/0
  ethernet cfm
  mep domain dom1 service ser1 mep-id 1
  propagate-remote-status
  !
  !
  !
```

**Verification**

```

show ethernet cfm interfaces [ <interface> ] llf [ location <node> ]
Defects (from at least one peer MEP):
A - AIS received           I - Wrong interval
R - Remote Defect received V - Wrong Level
L - Loop (our MAC received) T - Timed out (archived)
C - Config (our ID received) M - Missing (cross-check)
X - Cross-connect (wrong MAID) U - Unexpected (cross-check)
P - Peer port down        F - CSF received

GigabitEthernet0/1/0/0
MEP Defects                               Restore Timer
-----
100 R                                     Not running
101 None           10s remaining
102 RPF                                               Not running

GigabitEthernet0/1/0/1
MEP Defects                               Restore Timer
-----
110 None           3s remaining

GigabitEthernet0/1/0/2
MEP Defects                               Restore Timer
-----
120 P                                     Not running

```

## CFM and Y 1731 on VPLS over BGP Signaling

**Table 8: Feature History Table**

| Feature Name                              | Release Information | Feature Description                                                                                                                                                                                                                                                                   |
|-------------------------------------------|---------------------|---------------------------------------------------------------------------------------------------------------------------------------------------------------------------------------------------------------------------------------------------------------------------------------|
| CFM and Y 1731 on VPLS over BGP Signaling | Release 7.6.1       | VPLS over BGP Signaling services supports CFM continuity check, ITU-T Y.1731 compliant Delay Measurement Message (DMM), and Synthetic Loss Measurement (SLM) functions.<br><br>This feature allows you to effectively manage a network with L2VPN services running VPLS using BGP AD. |

Connectivity fault management (CFM) is a service-level Operations and Maintenance (OAM) protocol that provides tools for monitoring and troubleshooting end-to-end Ethernet services. This feature provides high-speed Layer 2 and Layer 3 services with high resiliency and less operational complexity to different market segments.

The CFM on VPLS over BGP Signaling feature allows you to effectively manage a network with L2VPN services running VPLS. The CFM provides proactive network management, troubleshooting, connectivity monitoring, fault verification, and fault isolation.

CFM on VPLS services supports CFM continuity check, ITU-T Y.1731 compliant Delay Measurement Message (DMM), and Synthetic Loss Measurement (SLM) functions.

DMM is used to periodically measure frame delay and frame delay variation between a pair of point-to-point Maintenance End Point (MEPs). Measurements are made between two MEPs belonging to the same domain and Maintenance Association (MA).

SLM is used to periodically measure Frame Loss and Forward Loss Ratio (FLR) between a pair of point-to-point MEPs. Measurements are made between two MEPs that belong to the same domain and MA.

### Supported Offload Types and Timer Values

The following are supported offload types:

- Hardware (HW) Offload type: The check message (CCM) timers for a CFM session are 3.3ms, 10ms, 100ms, or 1s.
- Non-Offload type: The CCM timers for a CFM session on a physical interface are equal to 10s or 1m.
- Software (SW) Offload type: The CFM session on a bundle interface. SW Offload type supports 1s, 10s, or 1m.

The following are the supported timer values:

- 3.3ms: Interval of 3.3 milliseconds
- 10ms: Interval of 10 milliseconds
- 100ms: Interval of 100 milliseconds
- 1s: Interval of 1 second
- 10s: Interval of 10 seconds
- 1m: Interval of 1 minute

The following combinations of scale and timers are supported:

- 8K HW Offload with timers of 3.3ms or higher
- 6K HW Offload + 2K SW Offload with timers of 1s or higher
- 4K SW Offload with timers of 1s or higher

### Feature Highlights

- CFM and Y 1731 on VPLS over BGP Signaling is now supported only on routers that have Cisco NC57 line cards that are installed and operate in native mode only.
- Supports single homing with one AC per PW.
- Support 1 and 2 Way DMM and SLM for UP and Down MEPs

### Restrictions

- Supports single homing with one AC per PW.
- Supports 1 Way DMM for the hardware with support for timing sync.
- The Cisco NC57 line cards operating in native mode support hardware timestamping only when the RP card is used as an RP-E card. With non-RP-E cards, the Cisco NC 57 line cards perform software timestamping and Delay Measurement Message (DMM) results have higher value for Mean, Maximum, and Minimum.



## Configure CFM and Y 1731 on VPLS over BGP Signaling

### Configuration Example

```

/* BGP AD based VPLS with single AC.
*/
l2vpn
bridge group cfmvpls
bridge-domain cfmvpls1
interface Bundle-Ether203.6001
!
vfi cfmvpls1
vpn-id 1001
autodiscovery bgp
rd auto
route-target 1001:1001
signaling-protocol bgp
ve-id 1

/* Global CFM UP MEP configuration */
ethernet cfm
domain cfmvpls level 3 id null
service cfmvpls1 bridge group cfmvpls bridge-domain cfmvpls1 id number 50001
continuity-check interval 1s loss-threshold 3
mep crosscheck
mep-id 4000

/* Global CFM DOWN MEP configuration */
ethernet cfm
domain cfmvplsdown level 3 id null
service cfmvplsdown1 down-meps id number 29001
continuity-check interval 1s loss-threshold 3
mep crosscheck
mep-id 4000

/* Global Y1731 DMM Configuration */
ethernet sla
profile dmml type cfm-delay-measurement
probe
send burst every 1 minutes packet count 30 interval 2 seconds
priority 4
schedule
every 5 minutes for 300 seconds
statistics
measure round-trip-delay
measure one-way-delay-sd
!
measure one-way-delay-ds
measure round-trip-jitter
measure one-way-jitter-sd
measure one-way-jitter-ds

/* Global Y1731 SLM Configuration */
ethernet sla
profile eth_sla_slm type cfm-synthetic-loss-measurement
probe
send burst every 1 minutes packet count 60 interval 1 seconds
priority 7
!

```

```

schedule
  every 5 minutes for 300 seconds
!
statistics
  measure one-way-loss-sd
!
  measure one-way-loss-ds
!

/* CFM UP MEP or DOWN MEP and Ethernet SLA applied to interface */
interface Bundle-Ether203.6001 l2transport
encapsulation dot1q 4002 second-dot1q 1
rewrite ingress tag pop 2 symmetric
ethernet cfm
  mep domain cfmvpls service cfmvpls1 mep-id 1
    sla operation profile dmml target mep-id 4000
!
  mep domain cfmvplsdown service cfmvplsdown1 mep-id 1
    sla operation profile eth_sla_slm target mep-id 4000

```

### Verification Example

Example output with the CFM Up MEP is configured.

```

Router(PE1)# show ethernet cfm peer meps interface bundle-Ether 203.6001
Flags:
> - Ok
R - Remote Defect received
L - Loop (our MAC received)
C - Config (our ID received)
X - Cross-connect (wrong MAID)
* - Multiple errors received
I - Wrong interval
V - Wrong level
T - Timed out
M - Missing (cross-check)
U - Unexpected (cross-check)
S - Standby
Domain cfmvpls (level 3), Service cfmvpls1
Up MEP on Bundle-Ether203.6001 MEP-ID 1

```

| St | ID   | MAC Address    | Port | Up/Downtime | CcmRcvd | SeqErr | RDI | Error |
|----|------|----------------|------|-------------|---------|--------|-----|-------|
| >  | 4000 | d46d.5059.1db0 | Up   | 15:33:42    | 56055   | 0      | 0   | 0     |

Example output with the CFM Down MEP is configured.

```

Router(PE1)#show ethernet cfm peer meps interface bundle-Ether 203.6001
Flags:
> - Ok
R - Remote Defect received
L - Loop (our MAC received)
C - Config (our ID received)
X - Cross-connect (wrong MAID)
* - Multiple errors received
I - Wrong interval
V - Wrong level
T - Timed out
M - Missing (cross-check)
U - Unexpected (cross-check)
S - Standby

```

```

Domain cfmvplsdown (level 3), Service cfmvplsdown1
Down MEP on Bundle-Ether203.6001 MEP-ID 1

```

| St | ID   | MAC Address    | Port | Up/Downtime | CcmRcvd | SeqErr | RDI | Error |
|----|------|----------------|------|-------------|---------|--------|-----|-------|
| >  | 4000 | 0024.f71d.af3e | Up   | 15:37:33    | 112487  | 0      | 0   | 0     |

Example output with the Ethernet SLA DMM statistics.

```

Router(PE1)#show ethernet sla statistics interface bundle-Ether 203.6001 domain cfmvpls
profile dmml
Source: Interface Bundle-Ether203.6001, Domain cfmvpls

```

```

Destination: Target MEP-ID 4000
=====
Profile 'dmml', packet type 'cfm-delay-measurement'
Scheduled to run every 5min first at 00:03:31 UTC for 5min
Round Trip Delay
~~~~~
1 probes per bucket
No stateful thresholds.
Bucket started at 03:18:31 IST Mon 14 February 2022 lasting 5min
 Pkts sent: 150; Lost: 0 (0.0%); Corrupt: 0 (0.0%);
 Misordered: 0 (0.0%); Duplicates: 0 (0.0%)
 Result count: 150
 Min: 290857.011ms; Max: 291925.308ms; Mean: 291367.479ms; StdDev: 317.339ms

```

#### Example output with the Ethernet SLA SLM statistics.

```

Router(PE1)#show ethernet sla statistics interface bundle-Ether 203.6001 domain cfmvplsdown
 profile eth_sla_slm
Source: Interface Bundle-Ether203.6001, Domain cfmvplsdown
Destination: Target MEP-ID 4000
=====
Profile 'eth_sla_slm', packet type 'cfm-synthetic-loss-measurement'
Scheduled to run every 5min first at 00:01:50 UTC for 5min
Frame Loss Ratio calculated every 5min
One-way Frame Loss (Source->Dest)
~~~~~
1 probes per bucket
No stateful thresholds.
Bucket started at 03:21:50 IST Mon 14 February 2022 lasting 5min
  Pkts sent: 300; Lost: 0 (0.0%); Corrupt: 0 (0.0%);
    Misordered: 0 (0.0%); Duplicates: 0 (0.0%)
  Result count: 1
  Min: 0.000%; Max: 0.000%; Mean; 0.000%; StdDev: 0.000%; Overall: 0.000%

```

