



Text Part Number: 78-5661-01 Rev. B0

Cisco IOS for S/390 Release 2.0 Release Notes

October, 1998

These release notes provide information for system administrators and installation managers who are responsible for the installation and support of the Cisco IOS for S/390 product. This document includes information specifically related to Cisco IOS for S/390 release 2.0 only.

This document contains these sections:

- “Enhanced Features,” page 2, provides a list of feature enhancements in Cisco IOS for S/390 release 2.0.
- “Product Changes,” page 3, describes changes to the product architecture from the previous release of Cisco IOS for S/390.
- “New Features,” page 7, describes features that were added in this release of Cisco IOS for S/390.
- “Cisco Connection Online,” page 8, describes the availability of information on the World Wide Web via the Cisco Connection Online.
- “Documentation,” page 8, describes the documentation for this release of Cisco IOS for S/390 and provides documentation updates for features and changes to the product that were received after the documentation CD went to press.
- “Installing Cisco IOS for S/390 Release 2.0,” page 23, provides information on converting to Cisco IOS for S/390 release 2.0 from a previous release of Cisco IOS for S/390.
- “Diagnosis and Problem Reporting,” page 33, documents problems that can occur if you are not using the correct versions of other products, or that worked differently in previous version of Cisco IOS for S/390. Also provides instructions on how to obtain a list of the reported problems that have been resolved in Cisco IOS for S/390 release 2.0.
- “SAS/C Usage Notes,” page 34 provides important information about the SAS/C compiler.
- “Converting from Cisco IOS for S/390 Release 1.0 to Cisco IOS for S/390 Release 2.0,” page 34, provides instructions for converting from the previous release of Cisco IOS for S/390.

Corporate Headquarters

Cisco Systems, Inc.
170 West Tasman Drive
San Jose, CA 95134-1706
USA

Copyright © 1998
Cisco Systems, Inc.
All rights reserved.

Enhanced Features

This section describes the new product features of Cisco IOS for S/390 release 2.0.

Improved Performance and Efficiency

- Increased throughput, reduction in CPU utilization, and inbound and outbound multiprocessing. TCP/IP processing is now multi-threaded instead of single-threaded. This is especially significant to FTP transmissions as it will let you obtain an aggregate transmission rate using up to four FTP applications running at the same time on four different CPUs. Outbound processing occurs in the dispatchable unit of the caller; Inbound processing is done on one or more SRBs to provide multitasking and proper accountability of CPU usage.
- Capability of configuring up to 25,000 tn3270 sessions.
- CLAW performance enhancements. With a Cisco 7xxx router and a Channel Interface Processor (CIP), large CLAW blocks can be used. Multiple packets are packed into one CLAW block to increase performance.

Improved Management

With Cisco IOS for S/390 release 2.0 you can dynamically:

- Activate, inactivate, define, and remove virtual IP addresses
- Alter, add, or delete the real IP addresses of interfaces
- Start or stop device drivers
- Start, stop, add, or remove interfaces
- Modify message routing/filtering at component and message suffix levels
- Update message routing—for problem diagnosis situations, message logging levels and destinations may be manipulated on the fly with operator commands

Enhanced Functionality

- The ACPEEP trace utility has been replaced by the TRACE utility that uses the MVS Component Trace facility, IPCS formatting routines, and an interactive TSO / component trace interface (TCPEEP).
- NETSTAT accepts commands from TSO, Telnet, and the operator console.
- SMF records are generated at various processing points such as connection establishment, connection termination, connection rejection, failed connection attempts, etc. for transport (TCP, UDP, Raw), Server Telnet, FTP, storage utilization, and drivers.
- Logging of tn3270 IP address-to-LU name mapping.
- The STOP command can be used for either a graceful shutdown or for an immediate shutdown.
- Messages can be selectively displayed or suppressed on a component or type basis.
- All Cisco IOS for S/390 address spaces now record trace information onto a common TRACE address space.

Enhanced APIs

- OS/390 OpenEdition (UNIX System Services) asynchronous I/O (required for DB2 V5 TCP/IP support) and SRB mode.
- Multiple BIND support for server applications (parallel processing for FTP, Telnet, and vendor applications).
- Enhanced TLI interface—data spaces, cross memory, SRB mode, etc.
- SAS 6.0 support.

Other Enhancements

- Year 2000 support.
- FTP server support for IP address as RACROUTE TERMID—allows security rules to deny FTP access unless permitted by IP address.
- Cisco router-based queuing—IP Type of Service (TOS) can be set for applications to better interface to Cisco queuing mechanisms like Weighted Fair Queuing (WFQ).

Product Changes

- The parameter WRELIM has been removed from the UDP and TCP statements. Buffering is handled automatically in Cisco IOS for S/390 release 2.0.
- Some of the control blocks for the **POOL** command have changed. The EPCB control block is now called the SEPM, the SRE is now called the SAW, and the ARCB, TUCB, and TSQB control blocks have been combined into the ATCB. The 256B pool no longer exists.
- The message ACC210I Internet Protocol Task Started no longer displays to indicate that startup has completed. A message will display indicating startup completion in Cisco IOS for S/390 release 2.0. The message number will vary, depending on the device you are using; the message text will be

```
Media media_name is now operational with one or more active interfaces.
```

Initialization and termination messages now appear in mixed case. This may impact some automated operations packages that search for messages to invoke some action. You should review these messages and take appropriate action.
- Some parameters for Cisco IOS for S/390 release 2.0 have been renamed to improve readability, but aliases have been added for the names used in Version release 1.0. The following names and aliases are available for Cisco IOS for S/390 release 2.0:

Table 1 Parameter Aliases

Parameters	Aliases
MAXSNDBUF	MAXSENDBUF MAXLSEND MAXLSND
MAXRCVBUF	MAXRECVBUF MAXLRECV MAXLRCV
DEFQSEND	DEFQSND
DEFQRECV	DEFQRCV
DEFSNDBUF	DEFSENDBUF DEFSEND DEFLSND
DEFRCVBUF	DEFRECVBUF DEFRECV DEFRLCV
MAXTSEND	MAXTSND MAXLTSEND MAXLTSND
MAXTRECV	MAXTRCV MAXLTRECV MAXLTRCV

Table 1 Parameter Aliases (continued)

MAXQSEND	MAXQSND		
MAXQRECV	MAXQRCV		
TADDRUSE	PORTUSE		
TADDRASSIGN	PORTASGN	PORTASSIGN	PORTASGN
KEEPALIVETYPE	KEEPALIVE		
KATIMER	KEEPALIVETIMER		
KACOUNT	KEEPALIVECOUNT		
ROUNDTRIPDEV	RTD		
ROUNDTRIPINIT	RTO		

- The ACPCFG00, APICFG00, and XITCFG00 configuration members have been removed. The TCP/IP stack configuration has moved into a new configuration member, TCPCFG00. The applications, such as Server FTP, Server Telnet, etc., moved to a new configuration member, APPCFG00.

Table 2 ACPCFG Member Changes

ACPCFG00	APPCFG00	TCPCFG00	IJTCFG00
HOST	GLOBAL		IFSPARM
<i>LNL_device</i>		<i>device</i>	
NETWORK		NETWORK	
ROUTE DEST		ROUTE DEST	
TIB TCP		TCP	
TIB UDP		UDP	
TIB RAW		RAW	
SERVICE	SERVICE		
TELNET	TELNET		
APPLNAME	APPLNAME		
TERMPROF	TERMPROF		
FTP	FTP		
GAT TYPE	GAT TYPE		
SMTP	SMTP		
LPR	LPR		
SMF			SMF

- Many APICFG00 parameters are now available through the following configuration members:
 - APPCFG00
 - DNRCFG00
 - IJTCFG00
 - SNMCFG00
 - TCPCFG00

As for parameters in the Cisco IOS for S/390 Release 1.0 configuration member APICFG00, the TPCB was replaced with the SPCB. You will only need 3 (default) because there are only 3 APIs.

CBUFs were replaced with the set of MBUFs. Previously, there were two CBUFs per session, one for input and one for output. Now all data is buffered in MBUFs, so there is no relation between the size of the CBUF pool, and the sizes of the MBUF pools. Pool sizes are based on the amount of data buffered, not on the number of endpoints.

In Cisco IOS for S/390 Release 2.0, usage of the API is no longer limited, so there was no need for the (1.0) API statement.

- The APP task group may have up to four tasks for parallel processing.
- The SSN parameter of member ACPCFG00 is now in the startup JCL.
- The startup JCL has the following changes:
 - WTPLOG11, WTPLOG12, WTPLOG13, and ACLOG DD statements have been replaced by T01LOG
 - T01LOG DD SYSOUT=&SOUT has been added
 - ACSNAP DD statements have been removed
 - PRFX=ACS parameter on the EXEC statement has changed to PRFX=T01
 - CNFG parameter has been added to the EXEC statement.
- The following pools that were in Cisco IOS for S/390 release 1.0 are not in Cisco IOS for S/390 release 2.0:
 - ARCB
 - CBUF
 - EPCB
 - SRE
 - TPCB
 - TSQB
 - TUCB
- The NETSTAT RTM (Recovery and Termination Manager) function is no longer supported. NETSTAN CONN COUNT and NETSTAT CNFG LNI provide similar information
- The NETSTAT WTOLOG function is no longer supported.
- The LOGSTAMP feature and task is no longer provided. All messages in the T01LOG are timestamped.

- Most of the prefixed messages have a consistent message format of the form *pppmmxxxs*, where:
 - *ppp* is a letter followed by 2 numbers which identifies the component:

<i>T00mmxxxs</i>	Messages issued by IFS common routines
<i>T01mmxxxs</i>	Messages issued by Cisco IOS for S/390 routines
<i>T02mmxxxs</i>	Messages issued by IUCV routines
<i>T03mmxxxs</i>	Messages issued by Component Trace routines

- *mm* is a pair of letters that identifies the subcomponent:

<i>pppAPxxxs</i>	Messages issued by API common application support routines
<i>pppCFxxxs</i>	Messages issued by Configuration
<i>pppCOxxxs</i>	Messages issued by Commutator service routines
<i>pppDNxxxs</i>	Messages issued by DNR (IFS routines only)
<i>pppF3xxxs</i>	Messages issued by FTP3
<i>pppGDxxxs</i>	Messages issued by GateD
<i>pppIFxxxs</i>	Messages issued by IFS
<i>pppIPxxxs</i>	Messages issued by Internet layer (IP, ICMP) routine
<i>IpppUxxxs</i>	Messages issued by IUCV transport provider
<i>pppLLxxxs</i>	Messages issued by Link layer routine
<i>pppNTxxxs</i>	Messages issued by Telnet
<i>pppOExxxs</i>	Messages issued by OpenEdition MVS transport provider
<i>pppPMxxxs</i>	Messages issued by port Mapper (IFS routines only)
<i>pppSFxxxs</i>	Messages issued by Server FTP
<i>pppSNxxxs</i>	Messages issued by Simple Network Management Protocol (SNMP)
<i>pppSOxxxs</i>	Messages issued by Socket API layer
<i>pppSTxxxs</i>	Messages issued by Server Telnet
<i>pppS4xxxs</i>	Messages issued by Spool#4
<i>pppTCxxxs</i>	Messages issued by Transport layer (TCP, UDP, RAW) routine
<i>pppUDxxxs</i>	Messages issued by Server UDP mini services
<i>pppUSxxxs</i>	Messages issued by User SMTP
<i>pppVTxxxs</i>	Messages issued by VTAMAPPL

- *xxx* is a number in the range of 000 - 999, uniquely identifying the message
- *s* is a letter indicating the severity level of the message:

<i>pppmmxxxR</i>	Response message produced in response to a command
<i>pppmmxxxF</i>	Fatal message signifying that a catastrophic error has occurred
<i>pppmmxxxE</i>	Error message indicating that some kind of error has occurred and action should be taken to correct it
<i>pppmmxxxW</i>	Warning message indicating that an action did not happen entirely correctly, but TCP could make adjustments or use defaults to correct the situation
<i>pppmmxxxI</i>	Informational message about operations and actions in progress
<i>pppmmxxxS</i>	Statistic message displaying metrics to be used for performance tuning, problem determination, and usage accounting
<i>pppmmxxxD</i>	Debug message to help diagnose problems or provide further details about operations and actions
<i>pppmmxxxT</i>	Trace messages recording specific events as they occur

- Results of using the TPOIPBRO option (query IP broadcast value) when issuing a TOPTION OPTCD=QUERY differ between Cisco IOS for S/390 release 1.0 and Cisco IOS for S/390 release 2.0. The result of the query on release 1.0 returns a value of 1 (allow broadcast), while the result on release 2.0 returns a value of zero (do not allow broadcast).

Returning the value of zero is correct since the default for Cisco IOS for S/390 release 2.0 is do not allow broadcast. Therefore, the SO_BROADCAST flag is not set. To set this flag to ON, you must run TOPTION with OPTCD=DECLARE and the TPOIPBRO option set to a value of 1 to override the default. After the flag is set, TOPTION OPTCD=QUERY will return a value of 1.

New Features

- Updated FTP Server provides compatibility with IBM TCP/IP FTP command
- Support for Inter-User Communications Vehicle (IUCV) sockets
- Support for Channel Data Link Control (CDLC) driver (3745)
- Support for TCPassist to allow TCP CHECKSUM processing to be off-loaded to Cisco 7000/7500 Series Channel Attached routers
- New Client FTP3 provides compatibility with IBM TCP/IP FTP client input and commands
- New storage parameters are provided to control virtual storage usage for TCP connections
- NETSTAT is available from TSO
- Most PARM members can be dynamically refreshed.

Cisco Connection Online

Cisco Connection Online (CCO) is Cisco Systems' primary, real-time support channel. Maintenance customers and partners can self-register on CCO to obtain additional information and services.

Available 24 hours a day, 7 days a week, CCO provides a wealth of standard and value-added services to Cisco's customers and business partners. CCO services include product information, product documentation, software updates, release notes, technical tips, the Bug Navigator, configuration notes, brochures, descriptions of service offerings, and download access to public and authorized files.

CCO serves a wide variety of users through two interfaces that are updated and enhanced simultaneously: a character-based version and a multimedia version that resides on the World Wide Web (WWW). The character-based CCO supports Zmodem, Kermit, Xmodem, FTP, and Internet e-mail, and it is excellent for quick access to information over lower bandwidths. The WWW version of CCO provides richly formatted documents with photographs, figures, graphics, and video, as well as hyperlinks to related information.

You can access CCO in the following ways:

- WWW: <http://www.cisco.com>
- WWW: <http://www-europe.cisco.com>
- WWW: <http://www-china.cisco.com>
- Telnet: cco.cisco.com
- Modem: From North America, 408 526-8070; from Europe, 33 1 64 46 40 82. Use the following terminal settings: VT100 emulation; databits: 8; parity: none; stop bits: 1; and connection rates up to 28.8 kbps.

For a copy of CCO's Frequently Asked Questions (FAQ), contact cco-help@cisco.com. For additional information, contact cco-team@cisco.com.

Note If you are a network administrator and need personal technical assistance with a Cisco product that is under warranty or covered by a maintenance contract, contact Cisco's Technical Assistance Center (TAC) at 800 553-2447, 408 526-7209, or tac@cisco.com. To obtain general information about Cisco Systems, Cisco products, or upgrades, contact 800 553-6387, 408 526-7208, or cs-rep@cisco.com.

Documentation

Cisco documentation and additional literature are available in a CD-ROM package, which ships with your product. The Documentation CD-ROM, a member of the Cisco Connection Family, is updated monthly. Therefore, it might be more current than printed documentation. To order additional copies of the Documentation CD-ROM, contact your local sales representative or call customer service. The CD-ROM package is available as a single package or as an annual subscription. You can also access Cisco documentation on the World Wide Web at <http://www.cisco.com>, <http://www-china.cisco.com>, or <http://www-europe.cisco.com>.

If you are reading Cisco product documentation on the World Wide Web, you can submit comments electronically. Click **Feedback** in the toolbar, select **Documentation**, and click **Enter the feedback form**. After you complete the form, click **Submit** to send it to Cisco. We appreciate your comments.

The Product Documentation Library

The Cisco IOS for S/390 manual set has been reorganized along functional lines. The complete manual set includes these documents:

- *Cisco IOS for S/390 Planning Guide*

Describes the Cisco IOS for S/390 architecture, how to prepare for installation, customize system security, and how to use OpenEdition and user exits. It also includes information about editing tools, information to help configure Cisco IOS for S/390 for Cisco routers and plan storage usage, and about the CDLC driver. This manual is targeted for Computer Operations personnel.

This document ships prior to shipment of the product.

- *Cisco IOS for S/390 Customization Guide*

Complete guide to customizing Cisco IOS for S/390 for your site. A bound copy of this document is included with the product shipment.

- *Cisco IOS for S/390 System Management Guide*

Describes the operator commands (startup and shutdown of Cisco IOS for S/390), how to use the System Management Facility (SMF), diagnostic procedures, diagnostic commands, and Inter-User Communications Vehicle (IUCV) sockets.

A bound copy of this document is included with the product shipment.

- *Cisco IOS for S/390 User's Guide*

Guide to the Cisco IOS for S/390 Client FTP2, Client FTP3, Client FTP, Server FTP, Telnet, and Mail commands, USPOOL, remote executor, API and socket applications, and programmable batch interface for Client FTP2 and Client FTP3.

- *Cisco IOS for S/390 Prefixed Messages*

Describes all messages that have an alphanumeric prefix and are printed to the console or the Cisco IOS for S/390 log files.

- *Cisco IOS for S/390 Unprefixed Messages and Codes*

Describes messages from FTP, Telnet, Mail, and general API return codes.

- *Cisco IOS for S/390 Assembler API Concepts*

Describes the concepts, flow, and operation of the Cisco IOS for S/390 API.

- *Cisco IOS for S/390 Assembler API Macro Reference*

Guide to the Assembler API macros.

- *Cisco IOS for S/390 C/Socket Programmer's Reference*

Describes calls for the basic C library and for the Socket API. This manual contains a chapter describing the OpenEdition (UNIX System Services) socket interface.

- *Cisco IOS for S/390 RPC/XDR Programmer's Reference*

Describes the RPC and XDR API calls.

Changes to the Documentation Set

The *Cisco IOS for S/390 Planning and Operations Guide* and *Cisco IOS for S/390 Installation Guide* of previous releases have been reorganized as described below:

- *Cisco IOS for S/390 Planning Guide*

This guide provides information to help you plan your installation of Cisco IOS for S/390. It will ship prior to shipment of the product.

- *Cisco IOS for S/390 System Management Guide*

This guide provides information about Cisco IOS for S/390 operation and system commands. It will ship with the product.

- *Cisco IOS for S/390 release 2.0 Release Notes* (this document)

The release notes now contain installation information. They will ship with the product.

Cisco IOS for S/390 User's Guide

A correction is required for Chapter 9, "Remote Executor," of the *Cisco IOS for S/390 User's Guide*. On page 9-2, in the section "What is the Remote Executor?" the following statement is incorrect:

This product uses version 5.5 of SAS C.

You must use SAS/C Release 6.00.

Cisco IOS for S/390 Planning Guide

The information in this section should be added to the *Cisco IOS for S/390 Planning Guide*.

SERVICE Startup Statement

Keywords `IBUF(aaa bbb)` and `OBUF(aaa bbb)` have been added to the SERVICE startup statement to allow default override:

`IBUF(aaa bbb)` If the service name is TELNET, you can use IBUF to specify the number of input buffers as *aaa*, and their size as *bbb*. The lower limits are (2 256); defaults are (1 1460).

`OBUF(aaa bbb)` If the service name is TELNET, you can use OBUF to specify the number of output buffers as *aaa*, and their size as *bbb*. The lower limits are (2 256); the defaults are (4 1460).

The minimum value for IBUF and OBUF is 512; it is the product of multiplying the buffer size times the number of buffers. The buffer size cannot be less than 256, and the number of buffers cannot be 0, so the lower limit would be (2 256) or (1 512).

Enhancements to the Global Exit Facility

The following enhancements have been made to the Global Exit Facility.

Exit Work Area

If requested, the exit facility provides a work area to the exit program upon each invocation, except the INIT exit point. Request the work area with the EWALENGTH parameter of the EXIT statement in member IJTCFGxx, or with a parameter returned by the program at the INIT exit point (the program parameter taking precedence).

The Exit Work Area (EWA) addressed will be passed to the exit program at each exit point as the fifth parameter, following the address of the message-writing routine.

Note The parameter lists for all exit points *must* be updated.

The EWA size can be from 1 to 65532 bytes. It is taken from pooled storage; the smallest pool that will satisfy the requested size will be used. Pool usage can be monitored via the IFS **POOL** command. One of the following pools will be used:

Table 3 EWA Pools

Pool Name	EWA Size
256B	1-252
512B	253-508
01KB	509-1020
04KB	1021-4092
08KB	4093-8188
16KB	8189-65532

Note These figures are provided to allow the exit program designer to make efficient use of the EWA buffers. It is important that the exit use only the size requested on the EWALENGTH parameter, or by the INIT exit. The exit facility monitors the exit program's use of the EWA, and will force an ABEND if an overrun is detected, *even if space remains in the buffer*.

Add the following parameters to the INIT exit parameter list, following the subsystem ID address:

Table 4 INIT Exit Parameters

Offset	Parameter Length	Data Length	Description
32	04	04	The address of the four-byte Cisco IOS for S/390 subsystem ID.
36	04	04	The address of a fullword area in which the exit program may put the size of the EWA to be obtained.
40	04	04	The address of a fullword area in which the exit program may put the address of a recovery routine to be called in the event the exit program ABENDs at a subsequent entry point.

Exit Recovery Routine

The exit program can supply the address of a recovery routine via a parameter returned at the INIT exit point. The exit facility calls this routine in the event of an ABEND in the exit program. The recovery routine is called in the same mode as the ABENDING exit program, and is passed the System Diagnostic Work Area (SDWA) address and the EWA address (if any). Since the exit's recovery routine is called after the system's Recovery and Termination Manager (RTM) has finished processing the ABEND, it should perform only local clean-up functions. Any updates to the SDWA are ignored. The recovery routine should *not* attempt to free the SDWA, since this will be done by the exit facility.

Recovery Exit

Exit Point: When an ABEND has occurred in an exit program.

Function: Perform clean-up associated with the exit program.

Dispatchable Unit: Identical with the ABENDING exit program.

Register contents are shown in the following table.

Table 5 Recovery Exit Register Contents

Register	Contents on Entry
R00	SDWA (if processing under an SRB, a copy of the SDWA)
R01	Exit Work Area address (if applicable)
R02-R12	Zeros
R13	Save area address
R14	Return address
R15	Entry point address

On return from the recovery exit, R13 must be restored.

Exit Parameter List Mapping Macro - T00DEXPL

A new macro, T00DEXPL, is supplied to map the parameter lists to the exit program at the various exit points. The macro is distributed in the SAMP library.

Customizing CA-ACF2 Version 6 or Later

A correction is required for Chapter 3 of the *Cisco IOS for S/290 Planning Guide*. Under the heading Customizing CA-ACF2 Version 6 or Later (page 3-12), step 2 is Update GSO Records for Cisco IOS for S/390. The code listed in this step is incorrect. The correct code is:

```
ACF
SET CONTROL(GSO)
INSERT CLASMAP.AC#CMD RESOURCE(AC#CMD) RSRCTYPE(SAF) ENTITYLN(8)
CHANGE INFODIR TYPES(D-RSAF)
INSERT SAFDEF.ACSECPC1 ID(ACSECPC) MODE(GLOBAL) REP
PROGRAM(BYPASS#1) RACROUTE(SUBSYS=SNSTCP,REQSTOR=ACSECPC)
INSERT SAFDEF.ACSECPC2 ID(ACSECPC) MODE(GLOBAL) REP
PROGRAM(BYPASS#2) RACROUTE(SUBSYS=SNSTCP,REQSTOR=ACSECPC)
INSERT SAFDEF.ACSECPC3 ID(ACSECPC) MODE(GLOBAL) REP
PROGRAM(BYPASS#3) RACROUTE(SUBSYS=SNSTCP,REQSTOR=ACSECPC)
INSERT SAFDEF.ACSECPC4 ID(ACSECPC) MODE(GLOBAL) REP
PROGRAM(BYPASS#4) RACROUTE(SUBSYS=SNSTCP,REQSTOR=ACSECPC)
INSERT SAFDEF.ACCFTP2 ID(ACCFTP2) MODE(GLOBAL) REP
PROGRAM(ACCFTP2) RACROUTE(REQUEST=EXTRACT)
INSERT SAFDEF.FTP ID(FTP) MODE(GLOBAL)
PROGRAM(FPT) RACROUTE(REQUEST=EXTRACT)
INSERT SAFDEF.FTP2 ID(FTP2) MODE(GLOBAL)
PROGRAM(FPT2) RACROUTE(REQUEST=EXTRACT)
INSERT SAFDEF.FTP3 ID(FTP3) MODE(GLOBAL)
PROGRAM(FPT3) RACROUTE(REQUEST=EXTRACT)
```

Cisco IOS for S/390 System Management Guide

The information in this section should be added to the *Cisco IOS for S/390 System Management Guide*.

Refreshing USSTAB

USSTAB tables can be refreshed with the **REFRESH** command.

In the “APP Commands” section, which describes the **REFRESH** command, the second sentence of the description of the **REFRESH** command, the USS Table should be added. That sentence should be corrected to read as follows:

“It can be used to refresh the LU pool, greeting member, or the USS Table used by Server Telnet.”

The correct syntax is:

```
[ APP ] REFRESH TASK ( n ) [ LUPARM ( mem_name ) | GREETING ( mem_name ) |
USSTAB ( tbl_name ) ]
```

Syntax Description

USSTAB (*tbl_name*) Specifies the USS Table *tbl_name* coded in the active APPCFG.xx SERVICE segment to be refreshed.

Note LUPARM, GREETING, and USSTAB are mutually exclusive.

The following is an example of the usage of the **REFRESH USSTAB** command.

```
REFRESH USSTAB( T01USS01 ) TASK( 1 )
```

The **REFRESH** command is described in the “Cisco IOS for S/390 Operation” chapter.

Parameters for the SVCDUMP Command

Two parameters have been added to the **SVCDUMP** command, ASID and JOBname. These parameters let the user request that other address spaces be dumped along with Cisco IOS for S/390.

ASID(*asid_list*) A list of address space IDs. Cisco IOS for S/390 will include these address spaces in the dump. This parameter can be combined with the JOBname parameter for a total of five address spaces.

The address space IDs may be listed in decimal or in hexadecimal notation, as x'999'.

JOBname(*jobname_list*) A list of one-to-eight character jobnames. Cisco IOS for S/390 will include these address spaces in the dump. This parameter can be combined with the ASID parameter for a total of five address spaces.

Note: If there is more than one job active in the system with the same jobname Cisco IOS for S/390 will dump the first one found in the Address Space Vector Table.

The **SVCDUMP** command is described in the “Cisco IOS for S/390 Operation” chapter.

Protocol Layer Events (Subtypes 110 - 123) Descriptions

The SMF subtype 110-123 records, described on page 3-17, are written to record certain protocol-related events, such as a bind or connect request.

The following table describes the relationship of each of these subtypes:

Subtype	Description
110	Endpoint create
111	TCP connect request
112	TCP accept request
113	TCP connection close
114	TCP bind
115	TCP unbind
116	TCP listen
117	UDP bind
118	UDP connect
119	UDP close
120	RAW open
121	RAW close
122	Endpoint destroy
123	Inbound connection failures

MU1IUCV USERMOD Correction

The zap example for EZASOK03 configuration overrides and defaults on page 4-14 and the USERMOD on page 4-15 are incorrect. Use USERMOD MU1IUCV in the SAMP data set instead.

NETSTAT RTM Command

The NETSTAT diagnostic commands are described beginning on page 5-12. The NETSTAT RTM command can be used by a Telnet user to display a continuous activity report on all active hardware interfaces. The frequency is determined by the value in seconds, and defaults to 9 if not entered. Permissible values are between 1 and 32767.

Once activated, the RTM command will continue to display a time-stamped connection counter, and LNI counts and rates. The display itself will appear after the specified interval in seconds, but the rate is based on a time difference between now and the last sampling. If multiple RTM commands are in effect, the rates will not always be consistently smooth.

To terminate the RTM command, press **Enter**.

Capture of User Data in a TLI Trace

You can use the trace facility or TCPEEP to capture user data in a TLI trace. The data is from the TPL field DABUF.

To capture and view user data, two actions are required.

- The filter MAXTLIDATA (alias MTLIDATA or MTDATA) must specify the maximum amount of data to be captured. The default is zero; the maximum is 65,535.

For example, the following command will capture up to 100 bytes of data:

```
GROUPS( ( TLI,'MTDATA( 100 ) ' ) )
```

- The FORMAT parameter must be specified for the maximum amount of data to be displayed. You may also specify which translation to use:
 - TLIDATA(*nn*) - mixed translation (default)
 - TLIEBCDIC(*nn*) - EBCDIC translation
 - TLIASCII(*nn*) - ASCII translation

For example, the following command will display up to 50 bytes of captured data:

```
FORMAT( TLIEBCDIC( 50 ) )
```

The **TCPEEP** command is described in the “Diagnostic Commands” chapter.

Cisco IOS for S/390 Customization Guide

The information in this section should be added to the *Cisco IOS for S/390 Customization Guide*.

TCPEEP NETIF Option

The default maximum data captured by the TCPEEP option NETIF is now 256 bytes of data, which includes device header, IP header, etc. A new filter option, MAXDATA (alias MDATA), allows resetting this to a maximum of 65,535.

This is an example of the usage of the MAXDATA (MDATA) filter option:

```
GROUPS( ( NETIF,'MDATA( 512 ) ' ) )
```

This command will capture up to 512 bytes of data. The **FORMAT** options DATA(*nn*), EBCDIC(*nn*), and ASCII(*nn*) still limit what is seen.

TCP MINDEV and RTO Defaults Changed

Two of the defaults in the TCPCFG00 file have changed.

For the TCP statement, the MINDEV parameter defaults to 40 (0.10 second).

Also on the TCP statement, the RTO parameter defaults to 0; range 0 - 6000.

APPEND Keyword for LUPOOL Statement

In configuration member APPLUP00, a new keyword, APPEND has been added to the LUPOOL statement.

LUPOOL NAME(*pool_name*)

APPEND(*lu_name*,...,*lu_name*)

Syntax Description

APPEND Specifies additional LU names for an LUPOOL. When APPEND is specified with a previously defined NAME, the LU names specified are appended to that previously defined for LUPOOL. There is no limit to the number of LUPOOL statements that can be specified with the APPEND keyword. Duplicate LU name checking is done for the complete list of LU names (original and appended).

Example:

```
LUPOOL  NAME (VLTPOOL0)
LU (T20000, T20001, T20002, T20003, T20004, T20005, T20006, T20007, T20008)
LUPOOL  NAME (VLTPOOL0) APPEND
LU (T20010, >T20011, T20012, T20013, T20014, T20015, T20016, T20017, T20018)
```

CDLC Considerations

The 3746-900 unit is configured with a network MTU size, but will override it with the lowest MTU size it encounters. That MTU size will be applied to whatever mainframe software will be running next. Therefore, if a small MTU size is used, that will become the restriction for subsequent IP packet sizes and may cause problems if fragmentation is not allowed. The CDLC MTU size should correspond to its network configuration parameter.

Recommendations on Setting TOS

The following recommendations for setting TOS (type of service) have been added to the *Cisco IOS for S/390 Customization Guide*.

When setting TOS, precedence bits should be set to zero. Of the next 4 bits, only one is to be set on in any one packet: 16 = mindelay, 8 = max thruput, 4 = reliability, 2 = min cost. These should be set as follows:

- Telnet = 16
- FTP Control = 16, Data = 8,
- SMTP Commands = 16, Data = 8
- DNS query = 16, zone transfer = 8
- SNMP = 4
- NNTP = 2

Note that Cisco IOS for S/390 does not configure TOS for SNMP or DNR queries, and NNTP is not implemented. Telnet and the FTP control connection can be configured in the Service statement. The FTP data connection can be configured in the FTP statement. The SMTP connection can be configured on the Service statement.

LOGGING Keywords Logically Grouped

The LOGGING command has been changed slightly to introduce a logical grouping of the keywords that control SYSOUT attributes and when the log is spun. The changes in this section apply to the *Cisco IOS for S/390 System Management Guide*.

This change makes the command easier to use in that you do not need to specify all of the keywords for an action, as is shown in the following table.

Keywords specified	Action
All the keywords are specified.	The LOGGING command will change all of the attributes as specified.
Some of the keywords are specified.	The specified attributes are changed, but the remaining attributes of the grouped attributes are set to the default.
None of the keywords are specified.	None of the attributes of the group will be changed, and any previous attributes will be carried forward.

The SYSOUT attributes that are grouped are:

- CLASS
- DEST
- FORM
- WRITER

The SPIN attributes that are grouped are:

- LINES
- MINUTES
- SYNC

Note The NOW keyword is not associated with LINES, MINUTES, and SYNC. The PRINT and WTO keywords are separate from each other, and from all the rest.

LOGGING Examples

Here are some examples of the usage of these grouped keywords.

LOGGING PRINT(ALL)

Prints all messages; leaves WTO, SYSOUT, and spin unchanged.

LOGGING WTO(ALL)

WTOs all messages; leaves PRINT, SYSOUT, and spin unchanged.

LOGGING CLASS(X)

Resets SYSOUT class to X; defaults DEST, FORM, and WRITER, and leaves remaining keywords unchanged.

LOGGING SPIN NOW

Spins the log now; leaves all specifications unchanged.

LOGGING SPIN(LINES(5000) MINUTES(60))

Resets spin to every 5000 lines or 60 minutes, whichever comes first; leaves remaining keywords unchanged.

LOGGING PRINT(ALL) WTO(ALL) WRITER(TOLSTOY) SPIN(SYNC) NOW

Prints and WTOs all message, resets SYSOUT writer to TOLSTOY and defaults CLASS, DEST, and FORM. Also resets spin to every hour on the hour, ignoring line count, and spins the log now.

Cisco IOS for S/390 Prefixed Messages

The following error messages should be added to the *Cisco IOS for S/390 Prefixed Messages* manual to support the **REFRESH USSTAB**:

These messages are described in the chapter “T01CFnnn Configuration Messages.”

T01CF080R

USSTAB *tbl_name* successfully refreshed for APP task *task_num*

Explanation The **REFRESH USSTAB(*tbl_name*) TASK(*task_num*)** operator command executed successfully.

T01CF081W

Refresh of USSTAB failed, APP task *task_num* inactive.

Explanation There was a negative response to a **REFRESH USSTAB(*tbl_name*) TASK(*task_num*)** operator command. The APP task *task_num* was not fully initialized or is in the process of stopping.

Recommended Action Wait for the APP task to complete initialization or restart the APP task *task_num* if it was stopped.

T01CF082W

Refresh of USSTAB failed, *tbl_name* not found.

Explanation There was a negative response to a **REFRESH USSTAB(*tbl_name*) TASK(*tasknum*)** operator command. *tbl_name* was not found in the JOBLIB/STEPLIB or link-listed library.

Recommended Action You will need to research what happened to the USS Table.

T01CF083W

Refresh of USSTAB failed, invalid format in *tbl_name*

Explanation There was a negative response to **REFRESH USSTAB(*tbl_name*) TASK(*task_num*)** operator command. *tbl_name* has an invalid format (it should start with X'BD').

Recommended Action You will need to research what happened to the USS Table.

T01CF084W

Refresh of USSTAB failed, *tbl_name* not used in APP task *task_num*

Explanation There was a negative response to **REFRESH USSTAB(*tbl_name*) TASK(*task_num*)** operator command. *tbl_name* for APP task *task_num* was not specified in the active APPCFGxx SERVICE segment.

Recommended Action Check the spelling of *tbl_name* and APP task *task_num* that may have been entered correctly.

T01NT069I

HH:MM:SS - nnn active TCP connections

T01NT070I

LNI aaaaaaaaa : bbb / ccc bytes/packdts in, at ddd bytes/sec

Syntax Description

aaaaaaaa	Hardware interface name
bbbb	Total byte count.
ccc	Total packet count.
ddd	Rate based on the time difference from the last sampling.

T01NT071I

LNI aaaaaaaaa: bbb/ccc/ bytes/packets out, at ddd bytes/sec

Syntax Description

aaaaaaaa	Hardware interface name
bbbb	Total byte count.
ccc	Total packet count.
ddd	Rate based on the time difference from the last sampling.

Cisco IOS for S/390 Unprefixed Messages and Codes

The information in this section should be added to the *Cisco IOS for S/390 Unprefixed Messages and Codes* manual.

C245xxxx (07xx) T012TCLS

The following table *replaces* Table 60 “X’C245’ Instance Codes” in the “API Diagnostic Codes” chapter:

Table 6 X’C245’ Instance Codes

4-byte code	2-byte code	Description
C2450001	0701	Unexpected abend

Table 6 X'C245' Instance Codes (continued)

4-byte code	2-byte code	Description
C2450002	0702	Recursive error
C2450003	0703	Error copying TPL to secondary
C2450004	0704	Error copying exit codes to TPL
C2450005	0705	VTPL abend
C2450020	0720	SAW not obtained
C2450021	0721	ASCB validation failed
C2450022	0722	TCB address is negative
C2450023	0723	31-bit TCB address passed
C2450024	0724	Close-pass:Close-pass pending
C2450025	0725	Close-pass:Accept pending
C2450026	0726	Close-pass:Receive pending
C2450027	0727	Close-pass:Send pending
C2450028	0728	Close-pass:Select pending
C2450029	0729	Close-pass:MBUFs awaiting send
C245002A	072A	Close-pass:UDP/RAW send pending
C245002B	072B	Close-pass:Shutdown pending
C245002C	072C	Close-pass:Open-old retracted
C245002D	072D	Close-pass:Close Pending
C245002E	072E	Open-old:Authorization failed
C245002F	072F	SEPM state NULL after suspend/callback
C2450030	0730	SEPM state DEAD after suspend/callback
C2450031	0731	Open-old:Failed by close-delete
C2450032	0732	TCP is terminating:SSIT is unavailable
C2450033	0733	TCP is terminating:SAVT is unavailable
C2450034	0734	TCP is terminating:SAVX is unavailable
C2450035	0735	TCP is terminating:SAVXLTCB is unavailable
C2450036	0736	Close-delete already in progress

C24Cxxxx (0Exx) T012TOPT

This table *replaces* Table 67 “X'C24C' Instance Codes” in the “API Diagnostic Codes” chapter:

Table 7 X'C24C' Instance Codes

4-byte code	2-byte code	Description
C24C0001	0E01	Unexpected abend
C24C0002	0E02	Recursive error
C24C0003	0E03	Error copying TPL to secondary
C24C0004	0E04	Error copying exit codes to TPL
C24C0005	0E05	VTPL abend
C24C0006	0E06	Error during rollback

Table 7 X'C24C' Instance Codes (continued)

4-byte code	2-byte code	Description
C24C0020	0E20	SAW not obtained
C24C0021	0E21	TLI state invalid
C24C0022	0E22	No option buffer provided
C24C0023	0E23	Option buffer length not positive
C24C0024	0E24	Option length not positive
C24C0025	0E25	OPTCD=API and option number negative
C24C0026	0E26	OPTCD=API and option number out of range
C24C0027	0E27	OPTCD=TP and option number not positive
C24C0028	0E28	Option number out of range
C24C0029	0E29	Option not supported
C24C002A	0E2A	Option length greater than maximum allowed
C24C002B	0E2B	OPTCD=VERIFY not supported (IOCTL)
C24C002C	0E2C	OPTCD=DEFAULT not supported (IOCTL)
C24C002D	0E2D	OPTCD=DECLARE not supported
C24C002E	0E2E	OPTCD=DECLARE user length too large
C24C002F	0E2F	T01XOPT1 ended in error
C24C0030	0E30	OPTCD=VERIFY not supported
C24C0031	0E31	OPTCD=VERIFY user length too large
C24C0032	0E32	Unknown exception from T01XOPT1
C24C0033	0E33	OPTCD=DEFAULT not supported
C24C0034	0E34	OPTCD=DEFAULT user length too large
C24C00 35	0E35	OPTCD=DECLARE not supported (IOCTL)
C24C0036	0E36	OPTCD=DECLARE user length too large (IOCTL)
C24C0037	0E37	IOCTL OPTCD=DECLARE and not HASN=SASN or sup
C24C0038	0E38	SET INTERFACE METRIC not in IFS address space
C24C0039	0E39	Option length greater than maximum allowed
C24C003A	0E3A	OPTCD=QUERY not supported
C24C003B	0E3B	OPTCD=QUERY not supported (IOCTL)
C24C003C	0E3C	OPTCD=QUERY user length too large (IOCTL)
C24C003D	0E3D	Unable to get MBUF

C25Bxxxx (1Dxx) T012TERR

The following table *replaces* Table 82 “X'C25B' Instance Codes” in the “API Diagnostic Codes” chapter:

Table 8 X'C25B' Instance Codes

4-byte code	2-byte code	Description
C25B0001	1D01	Unexpected abend

4-byte code	2-byte code	Description
C25B0002	1D02	Recursive error
C25B0003	1D03	Error copying TPL to secondary
C25B0004	1D04	Error copying exit codes to TPL
C25B0005	1D05	VTPL abend
C25B0006	1D06	Abend obtaining TEM storage
C25B0007	1D07	Abend building TEM
C25B0020	1D20	SAW not obtained
C25B0021	1D21	TPL is active
C25B0022	1D22	STORAGE OBTAIN for TEM failed
C25B0023	1D23	Summary format not supported

C25Fxxxx (21xx) T01PSTUB

This table replaces Table 84 “X’C25F’ Instance Codes” in the “API Diagnostic Codes” chapter:

Table 9 X’C25F’ Instance Codes

4-byte Code	2-byte Code	Description
C25F0001	2101	Unable to obtain TSCE
C25F0002	2102	SAS/C initialization failed
C25F0003	2103	SAVT not available
C25F0004	2104	PC not available
C25F0005	2105	TCP restarted after AOPEN
C25F0006	2106	Subsystem not active
C25F0007	2107	PC not available
C25F0008	2108	<not assigned>
C25F0009	2109	Subsystem not found
C25F000A	210A	Subsystem not active
C25F000B	210B	SAS/C termination failed
C25F000C	210C	TCP restarted after AOPEN
C25F000D	210D	User active during TCP restart

C262xxxx (6Fxx) T012TPLK

There is a duplicate entry in Table 85, “X’C262’ Instance Codes,” in the “API Diagnostic Codes” chapter. The second C262000A 4-byte code entry:

4-byte Code	2-byte Code	Description
C262000A	6F0A	SEPM storage verification failed

...should be C262000B and the 2-byte code should be 6F0B, as follows:

Table 10 X'C262'Instance Codes

4-byte Code	2-byte Code	Description
C262000B	6F0B	SEPM storage verification failed

C909xxx T01SISND

The following 4-byte code has been added to Table 116, “X’C909’ Instance Codes,” in the “API Diagnostic Codes” chapter:

Table 11 X’C909’ Instance Codes

C909000C	Unable to find a route because SO_DONTROUTE was set.
----------	--

Installing Cisco IOS for S/390 Release 2.0

This section contains information about installing Cisco IOS for S/390 release 2.0.

Installation Requirements

Cisco IOS for S/390 Version release 2.0 is composed of the base Cisco IOS for S/390 release 2.0 distribution tape and a tape containing additional PTFs. You must install both tapes.

MVS Releases

Cisco IOS for S/390 release 2.0 requires MVS/ESA Release 5.1 or higher. MVS/SP releases are not supported. OpenEdition support is available only at MVS/ESA Releases 5.x and above.

The MVS PTF associated with APAR **OW30322** must be applied prior to starting Cisco IOS for S/390 release release 2.0.

APF Authorizations

The PFSLOAD library is used with OpenEdition and contains Physical File System (PFS) modules. It must be APF-authorized to work correctly.

If you use the SASLINK data set as described in the ALLOCT00 section of these instructions you must also APF-authorize that library.

Link List Data Sets

TCPLOAD must *never* be in the link list. If SASLINK is used, you must place it after the LINK library in any concatenation to ensure that the Cisco IOS for S/390 version of LSCNCOM is used.

Automated Operations Impact

The message ACC210I Internet Protocol Task Started no longer displays to indicate that startup has completed. A message will display indicating startup completion in Cisco IOS for S/390 release 2.0. The message number will vary, depending on the device you are using. The message text will be

Media `media_name` is now operational with one or more active interfaces.

Callable System Services Library

You must have the Callable System Services library, `SYS1.CSSLIB`, available for the installation. Modules from this library are linked with Cisco IOS for S/390 release 2.0 for OpenEdition support. This library is distributed with MVS/ESA. If you do not have this library available, OpenEdition support will not function properly.

TSO/E

New users must verify that the IBM program product TSO/E is installed. Cisco IOS for S/390 configuration files are parsed using TSO/E parsing routines and S0C4 ABENDs can result if these routines are not available.

ACF/2

For some users of CA-ACF2, the CA-ACF2 fixes listed here affect the way the Cisco IOS for S/390 SAF security interface to CA-ACF2 works. These fixes should be reviewed by the CA-ACF2 Systems Programmer to determine if they are still applicable or have been superseded by later maintenance.

Table 12 CA-ACF2 Fixes

ACF2 R _{release 2.0}	
Fixes	ACF2 R6.0 Fixes
TW87092	G016544
TW95626	G025907
TW95673	G023824
CO96846	G026166
CO97436	G026702
	G031029
	TA1294B

SAS/C Release Level

Cisco IOS for S/390 release 2.0 is designed to work with SAS/C Release 6.00, which is included with the product. If you are not running with the correct SAS/C libraries, unpredictable results may occur.

The zap associated with Usage Note 1670 for SAS/C 6.0 must be applied in order to run applications via IUCV over the SAS LSCNCOM interface, including SAS/connect.

Asynchronous Sockets

Cisco IOS for S/390 release 2.0 supports asynchronous socket calls from OpenEdition. The following system levels are required to run this option:

- OS/390 V1.3 requires PTF level 9705 or higher
- DB2 V5 requires PTF level 9708 or higher

- DB2/CONNECT V5 requires Fix Pack WR09014. *Do not apply Fix Pack WR09024.*

Common Inet Sockets in OpenEdition

You must install the APAR **OW20620** in order to use Common Inet sockets in OpenEdition.

RS6000

You must install the RS/6000 patch **U432867** to use the CLAW driver. With earlier RS/6000 maintenance, MVS error recovery problems can occur.

VTAM Release 3.3

VTAM Release 3.3 users must apply PTF **UY67100** or **UY69746**, or their equivalent. If this is not possible, contact Cisco TAC and request APAR **MB18602**. If the PTFs or APAR are not applied, problems can occur handling control vector X'5F' and cause connection errors.

MVS/ESA Release 5.1 Considerations

Interlink 3722 users must install the latest release of the CETI microcode. Interlink 3762 users must install the latest release of the ECA CETI microcode. The CETI driver may terminate at startup if you are using earlier releases.

Novell LAN Workplace

We recommend that you apply Novell fixes **LWP41N** and **LWP168** (to correct an FTP hang condition). These fixes are available on NetWire.

Walker, Richer, & Quinn Software

If you are using software from Walker, Richer, & Quinn, we recommend that you install version 2.1.2 or above of Reflection 8+ (for DOS using IBM 3270) and Version 2.2 of WRQNET TCP/IP. Users of earlier releases can experience a tn3270 hang condition.

Hardware Requirements

These minimum hardware levels are required for Cisco IOS for S/390 release 2.0, including Cisco IOS for S/390 Fault Tolerant:

Interlink 3762 ECA CETI 3.0 Checksum B030

Interlink 3762 TCA 4.0 Checksum 5841

Interlink 3762 FCA 2.5 Checksum 6273

Interlink 3722 ELC2 CETI 2.2 Checksum 67FE

Interlink 3722 ELC2 8232 3.1 Checksum 4132

IBM 2216 MAS V1 R1.1

IBM 3172 Model 3 ICP 3.3

IBM 3172 Model 1 ICP 1.1 and higher (ICP 1.1 with patch PLXXX48)

NSC HYPERchannel DX CDA 7.2

IP Hardware, Cisco IOS Software, and CIP Microcode Compatibility

The following table lists the compatibility requirements for Cisco IOS for S/390. However, we recommend that you refer to the CCO service and your Systems Engineer to choose the most appropriate level for your configuration.

Table 13 Hardware/Software/Microcode Compatibility

CIP Hardware Version	Minimum Cisco IOS Release Required	Minimum CIP Microcode Version Recommended
CIP 4.4 or later	11.0(14a)	cip21-14
CIP 2 5.x or later	11.0(13a)BT	cip22-17
	11.1(9)	cip22-14
	11.2(4)	cip22-14
	11.2(9)BC	cip24-1
	11.3(0.6)	cip25-2
	11.3(3)T	cip26-0
CPA	11.3(3)T	xcpa26-0

Note For the CLAW PACKING feature, you must use IOS level 11.2(14)BC and CIP microcode version cip24-6 and above.

Installation Process

Use these instructions to install Cisco IOS for S/390 release 2.0 and to upgrade from a previous release of Cisco IOS for S/390.

Note In order to avoid a potential CSA overlay problem, *do not* use the same subsystem ID for Cisco IOS for S/390 release 1.0 and Cisco IOS for S/390 release 2.0 stack address spaces. To determine which subsystems are in use on your system, execute the MVS command **D SSI**.

Control File JCL

Copy and execute the JCL below to unload the control file from which you will be able to install and customize Cisco IOS for S/390 release 2.0. The control file is on your Cisco IOS for S/390 release 2.0 base tape.

```
//UNLDTCP JOB (Cisco IOS for S/390),'UNLOAD TCP CNTL',MSGCLASS=X
//*
//UNLOAD EXEC PGM=IEBCOPY
//INDD DD DSN=CNTRL,DISP=SHR,VOL=SER=TCP001,
// LABEL=(27,SL,EXPDT=98000),UNIT=tapunit
//OUTDD DD DSN=trgindx.CNTRL,DISP=(NEW,CATLG,DELETE),
// VOL=SER=trgvol,SPACE=(TRK,(30,2,25)),UNIT=trgunit,
// DCB=(DSORG=PO,RECFM=FB,LRECL=80,BLKSIZE=6160)
//SYSPRINT DD SYSOUT=holdc1
//SYSIN DD *
COPY INDD=((INDD,R)),OUTDD=OUTDD
```

Note Some members of the CNTL library are now under SMP/E control and some members will be loaded as part of the APPLY process. When modifying the ALLOCT00 JCL stream, verify that the TCPJCL DDDEF points to your CNTL library. Also, you should exit the CNTL library as soon as the INSTSMPE job stream is submitted. Keeping the data set open in your TSO session will cause the APPLY job to fail.

Allocate the Data Set Names for Cisco IOS for S/390 release 2.0

References to member names in the following instructions are located in the control file that you loaded onto your system in Control File JCL.

1 TCPNAMES

Member TCPNAMES in the CNTL library is used to customize all other installation members.

The TCPNAMES member, a REXX EXEC, lets you assign consistent data set name allocations. You can customize member TCPNAMES so that you do not need to edit the other installation members manually.

Step 1 Edit the data set name symbolics to be consistent with naming conventions of your site.

Verify adequate space on the volume specified.

The LNKINDX data set is allocated as a SYS1 data set in job ALLOCT00. You can change to a different high level node if you do not have authority to allocate SYS1.

Step 2 Copy the TCPNAMES member to a CMDLIB listed in the SYSPROC concatenation of your TSO logon procedure as described below.

Determine the name of your logon procedure. It is identified on the first screen of your TSO logon.

Determine the data set in which your logon procedure is located. It is most likely in SYS1.PROCLIB. If not, from your TSO command line execute the command **TSO LISTA**, which will list all data sets allocated to your TSO session. Your TSO logon procedure is most likely located in a data set with final node of PROCLIB.

Determine the CMDLIB you will use. Select the member containing your logon procedure, find the SYSPROC DD, and select a CMDLIB to copy TCPNAMES into.

If you are copying TCPNAMES into a VBA library, you must delete the line numbers that appear in columns 73 through 80 after you copy it in.

2 JOBCARD

Member JOBCARD in the CNTL library is used by the TCPNAMES EXEC to customize the jobcards of all other installation members.

Choose a jobcard and copy it into the CNTL data set member JOBCARD.

If you are using JES3, replace the JOBPARM card with the following:

```
//*MAIN LINES=(999,W)
```

3 ALLOCSMP

Member ALLOCSMP allocates the data sets that contain your consolidated software inventory. Edit and submit member ALLOCSMP according to the instructions below.

Before submitting the ALLOCSMP member, consider the following:

— ALLOCSMP requires 53 cylinders.

- Verify that the Linkage Editor/Binder attributes for the CSI include NCAL, LET, and SIZE=(660000,160000). If you are using the linkage editor you must remove the NCAL, LET, and SIZE parameters from the ALLOCSMP JCL. You must also change your maximum return code to a 4.
- For users running MVS/ESA 4.3 or above, Binder is now supported. To use the Linkage Editor, update the options entry for IEWL to point to HEWLF064. In Cisco IOS for S/390 release 2.0 the default is to use HEWLH096, which invokes the Binder.
- Cisco IOS for S/390 release 2.0 must be installed into a new CSI; you cannot use a shared CSI. Data set allocation changes in this release will cause attempts to install over an existing release to fail.

Edit the ALLOCSMP member by entering **TCPNAMES** at the command line.

Submit ALLOCSMP.

4 ALLOCT00

Member ALLOCT00 in the CNTL library allocates the libraries that will contain the Cisco IOS for S/390 base product.

Before submitting the ALLOCT00 member, consider the following:

ALLOCT00 requires 2333 tracks. You may choose to distribute some of the libraries across multiple volumes. This requires manual editing of ALLOCT00 after you execute TCPNAMES.

The PFSLOAD and FTPLOAD libraries are allocated. The PFSLOAD library is used with OpenEdition and contains Physical File System (PFS) modules. It must be APF-authorized. If you are not using OpenEdition, the library is not required. The FTPLOAD library will contain the FTP3 load module for IBM-FTP client compatibility.

Edit the ALLOCT00 member by entering **TCPNAMES** at the command line.

Submit ALLOCT00.

5 INSTSMPE

Member INSTSMPE in the CNTL library is used to install the base product.

Before submitting the INSTSMPE member, consider the following:

The Cisco IOS for S/390 release 2.0 product consists of four FMIDs. You must apply the Cisco IOS for S/390 FMID, **T01T520**, and the translate table FMID, **T01X520**. Optional FMIDs are the development FMID, **T01D520**, and the SAS 6.0 runtime FMID, **SAS0600**. No user changes are required.

You may submit only the RECEIVE portion of this job first. This will let you review the HOLDDATA, especially any hold action that may appear, and take appropriate action. It will also let you add additional BYPASS HOLD keywords to your APPLY statement.

Edit the INSTSMPE member by entering **TCPNAMES** at the command line.

If you are using a tape management system such as CA1, you must modify the label parameter on your DD statements to include EXPDT=98000.

```
LABEL=1,NL, ,EXPDT=98000
```

If you are using JES3, replace the JOBPARM card with the following:

```
//*MAIN LINES=(999,W)
```

Submit INSTSMPE.

Note Exit the CNTL library as soon as the INSTSMPE job stream is submitted. Keeping the data set open in your TSO session will cause the APPLY job to fail.

6 HOLDDATA

Before installing system maintenance, obtain the most recent HOLDDATA file. You can obtain this file through anonymous FTP by logging in to `ftp.interlink.com` and requesting it as shown in the following example. For user ID, use `anonymous`; for password, use your email address.

ftp2

open ftp.interlink.com

cd pub/ptf520

ascii

get hold.txt

At the prompt for a storfile name, enter the following (including the single quotation marks):

'your_80byte_pds(member)'

quit

This file is in ASCII and is to be downloaded to MVS for processing by SMP/E. Translation of ASCII text to EBCDIC is automatic during transfer.

PTFs may have a HOLD status associated with them that should be reviewed before you begin the APPLY process. Review the ++HOLD requirements after you RECEIVE the SYSMODS. When satisfied, use a BYPASS(HOLDSYS) on the APPLY command and rerun the APPLY job without the CHECK parameter.

Use this HOLDDATA file as your SMPHOLD file in the SMPHOLD DD statement. If you do not have Internet access, contact Cisco TAC for the latest HOLDDATA file.

7 SMPECUMT

Member SMPECUMT in the CNTL library is used to apply maintenance to the base product.

The non-labeled (VOL=SER=PTFTAP) maintenance tape distributed with the product contains the latest maintenance for the Cisco IOS for S/390 product. Apply this maintenance, as well as any maintenance obtained interactively from our web site, prior to beginning any customization, as configuration files or parameters may have changed.

Before submitting the INSTSMPE member, consider the following:

- You may submit only the RECEIVE portion of this job first. This will let you review the HOLDDATA, especially any hold action that may appear and take appropriate action. It will also let you add additional BYPASS HOLD keywords to your APPLY statement.

Edit the SMPECUMT member by entering **TCPNAMES** at the command line.

- If you are using a tape management system such as CA1, you must modify the label parameter on your DD statements to include EXPDT=98000.

```
LABEL=1,NL, ,EXPDT=98000
```

- If you are using JES2, add the following statement:

```
/*JOBPARM L=9999
```

— If you are using JES3, add the following statement:

```
//*MAIN LINES=(999,W)
```

— Verify that the tape unit is correct. It is hardcoded as CART.

Submit SMPECUMT.

SMPECUMT will generate the following message:

```
GIM34701E: SMPE expected to find ++MCS
```

This is expected and normal.

View the SDSF job output log to verify accuracy of the job. Execute the ISPF Browse or SDSF View command **F 'APPLY PROCESSING WAS SUCCESS' ALL**. Confirm that the number of occurrences matches the number of PTFs you applied.

8 Web Site PTFs

If you require additional PTFs that are not on the CUM tape received with your installation package, access the following web site for a list of PTF numbers available:

<http://www.interlink.com/support/>

Scroll down approximately two pages and select the hypertext */pub directory*.

Select the *ptf520* directory.

Note Sometimes the incorrect year appears in the PTF creation dates. This is a known bug with the Microsoft Internet Explorer and has no effect on the validity of the PTFs. When using Microsoft Internet Explorer to access a PTF directory, the year in the date adjacent to a file is displayed as the current year if the file has not been updated for six months, even though the file might have been created in the previous year.

Create a data set to contain the PTFs you will select. we recommend you use the same naming convention you used in the TCPNAMES High Level Qualifiers (HLQ) for your LNKINDX variable.

When you know the PTF numbers you want from the web site, set up a batch job with multiple **GET** commands using the specific PTF numbers and FTP to the Interlink anonymous FTP site. For User ID, use *anonymous*; for password, use *guest*.

open ftp.interlink.com

anonymous

guest

bin

cd /pub/ptf520

get TPnnnnn.BIN 'your_data_set_name(TPnnnnn)'

bye

Customization

This section describes the members that can be customized.

PARM Customization

The statements described in this section are all described in the *Cisco IOS for S/390 Customization Guide*. That document is the definitive source of information for these members. These members are all shipped with the product.

Note PARM members are now under SMP/E control. In order to avoid possible overwrite by future PTFs, copy your 00 members to 01 or another suffix of your choice. You must also make the appropriate adjustments in members `STARTxx`, `DNRCFGxx`, and `TCPCFGxx` which point to other PARM members.

Some of the Cisco IOS for S/390 release 1.0 members have been changed or deleted and many parameters have been relocated to different members in Cisco IOS for S/390 release 2.0. We recommend that you select your Cisco IOS for S/390 release 2.0 members and then split screen to browse your Cisco IOS for S/390 release 1.0 members in order to transfer the appropriate parameters to the correct Cisco IOS for S/390 release 2.0 members. Use the chart at the beginning of this document to see where parameters were in Cisco IOS for S/390 release 1.0.

APPCFGxx: Verify that the service statements that were in member `ACPCFGxx` in Cisco IOS for S/390 release 1.0 are now in `APPCFGxx`.

APPLUPxx: The `LUPOOL` statement has a new `ALLOCATE` parameter:

`ALLOCATE(FIRST)` Directs `LUPOOL` to allocate the first available LU.

Due to performance considerations this is the preferred startup option

This is the default.

`ALLOCATE(NEXT)` Directs `LUPOOL` to allocate LUs in sequential order.

This option adds flexibility in an error LU situation. This option should be specified at a site only at the direction of TAC personnel when the VTAM network is not working properly.

DNRxxxxx: In general, you can transfer or copy these members from the Cisco IOS for S/390 release 1.0 PARM library to the Cisco IOS for S/390 release 2.0 PARM library. However, be sure to verify accuracy and validity of the parameters and their placement.

DNRALCxx: Users running in a multihomed environment must place entries in the `DNRALCxx` member for all non-loopback LNIs to allow domain name resolution to occur. If only one is defined, expect the following message:

```
T01CF150E APP configuration error: invalid SUBSYS Name subsysname
```

Processing continues after the message displays.

DNRCFG01: Replace `NAMESERVER(NONE)` with `NAMESERVER(DNRNSC01)`. You will be customizing this member later.

DNRNSC01: Complete the lines requesting that you “set server for your domain.”

IJTCFGxx: The existing Cisco IOS for S/390 release 1.0 authorization keys work for Cisco IOS for S/390 release 2.0 if you use the same CPU. CPU serial numbers, processor status, and other information can be obtained via execution of the MVS command `D M=CPU`.

STARTxx: To aid in diagnosis, insert the following statement on the first line of the `STARTxx` member:

MODIFY TRACE ON SIZE(256)

TCPCFG01: There is a new NETMASK parameter that lets the Network Information Center (NIC) divide the Class B addresses into Class C addresses to alleviate some of the worldwide IP address shortages. If your installation is affected you will have already applied to the NIC for these addresses.

USERMOD Customization

The statements described in this section are all described in the *Cisco IOS for S/390 Customization Guide*. These members all ship with the product.

UMODTRAN: Read the section “Maintaining Translation Tables Using UMODTRAN” in the “Telnet and tn3270 Configuration Chapter” of the *Cisco IOS for S/390 Customization Guide*.

UMODAPPL: This is the usermode that you will most likely apply. In order for UMODAPPL to run, you must modify member APPLNAME in the SAMP library with your correct VTAM APPL.

UMODPOOL: UMODPOOL uses member ACCPOOL in the SAMP library. Old style 3174 controllers did not let things start with 01, so the starting name is ACSVLT02.

Invoking Cisco IOS for S/390 Release 2.0

The startup member, RUNTCP, is located in the control library you designated in your installation JCL. This member will invoke Cisco IOS for S/390 release 2.0. You will have a choice to submit RUNTCP as either a started task or as a batch job.

Before submitting the RUNTCP member, consider the following:

- The CMND data set is no longer allocated or used. The START00 member is now located in the PARM data set. The RUNTCP member in the CNTL data set reflects this change.
- Two libraries, PFSLOAD and FTPLOAD, are allocated. The PFSLOAD library is used with OpenEdition and contains Physical File System (PFS) modules. It must be APF-authorized to work as specified in the Installation Requirements section earlier in this document. If you are not using OpenEdition, the library is not required. The FTPLOAD library is reserved for future use.

Note TCPLOAD must *never* be in the linklist. If SASLINK is used, you must place it after the LINK library in any concatenation to ensure that the Cisco IOS for S/390 version of LSCNCOM is used.

Edit the RUNTCP member.

- Do *not* execute TCPNAMES.
- Change the symbolic ‘TRGINDX’ to the value you specified in member TCPNAMES.
- Verify that the symbolic SSN=ACSS is available for use. The MVS command **D SSI** will display subsystem names that have been invoked during the life of the current IPL. You can use ACSS if it either does not display or if it shows as inactive. If ACSS is active, you must choose a different name for your subsystem.
- Verify that the symbolic ‘SRC=%’ is available for use.
- If you are using a user VTAMLIB, you must add it to your STEPLIB concatenation to make sure RUNTCP can find your USSTAB.
- You need to add one of the following lines immediately after the JOBCARD to support diagnostics.

- If you are using JES2 add:

```
/*JOBPARM LINES=9999
```

- If you are using JES3, add:

```
//*MAIN LINES=(999,W)
```

- To prepare RUNTCP as a batch job:

- Complete your RUNTCP JOBCARD and add the following JCL statements to the end of the RUNTCP JCL stream:

```
// PEND
//label EXEC TCPIP
```

To prepare RUNTCP as a started task:

- Delete the RUNTCP JOBCARD and comments that appear prior to the PROC statement.
- Copy member RUNTCP into a system PROCLIB.

Submit RUNTCP.

- To submit RUNTCP as a batch job, submit member RUNTCP.
- To submit RUNTCP as a started task, issue the MVS command **S RUNTCP**.
- The message ACC210I Internet Protocol Task Started no longer displays to indicate that startup has completed. A message will display indicating startup completion in Cisco IOS for S/390 release 2.0. The message number will vary, depending on the device you are using. The message text will be

```
Media media_name is now operational with one or more active interfaces.
```

To stop RUNTCP, issue the MVS command **F RUNTCP,P CLEAR** and answer YES to the reply. This reply is generated if you have the PROMPT parameter specified in your IJTFCGxx member.

If RUNIUCV is to be stopped, it must be done after RUNTCP has terminated.

Diagnosis and Problem Reporting

Generally, Cisco needs the following documentation to help diagnose problems thoroughly:

- TCP SNAP
- TCPEEP
- SVC dump of the Cisco IOS for S/390 and other related address spaces
- JCL output of the Cisco IOS for S/390 job

Obtaining GTF Output

The “Command Scripts” section of Chapter 2, “Cisco IOS for S/390 Operation” in the *Cisco IOS for S/390 System Management Guide* provides a sample command script to start GTF and turn on tracing.

Obtaining a SNAP Dump

As soon as a problem occurs, enter the following MVS command to your Cisco IOS for S/390 address space:

F RUNTCP,TCP SNAP ALL

Obtaining a TCPEEP

Read the *Cisco IOS for S/390 System Management* for information to help you set up and submit your trace address space and submit the TCPEEP TSO command.

Obtaining an SVC Dump

Read the IBM document *MVS/ESA System Commands Reference Summary* for the syntax of the required **DUMP** commands. In particular, include all jobs involved in the problem using the JOBNAME parameter of the **DUMP** command.

Obtaining JCL Output

Copy the JCL output of RUNTCP to a file using the following procedure:

- If you are using JES2/SDSF, type **XDC** beside the job listed in SDSF and follow the panel instructions. This will let you copy to a data set of your choice. Generally, for every thousand lines of job output you need three 3390 tracks.
- If you are using JES3, you may use **FLASHER** or a similar product to copy the RUNTCP output to a data set in a similar fashion.

SAS/C Usage Notes

You *must* use the SAS 6.0 compiler, header files, object files, and runtime libraries to **COMPILE** and **LINK** using the Cisco IOS for S/390 release 2.0 socket library

You can run a down-level (SAS 5.5) **c** program against Cisco IOS for S/390 release 2.0, and it can be compiled and linked using the Cisco IOS for S/390 release 1.0 (or lower) socket library. However, it *must* be run using the SAS 5.5 runtime library. This program can then run over the Cisco IOS for S/390 release 2.0 stack.

- Mixing any SAS 6.0 modules/headers with SAS 5.5 modules/headers will cause problems.
- Mixing any Cisco IOS for S/390 release 2.0 socket modules/headers with Cisco IOS for S/390 release 1.0 socket modules/headers will cause problems.
- Mixing runtime modules between releases will cause problems.

In addition, in SAS 6.0, **LSCNCOM** is always dynamically loaded. If linked with the application program in 6.0, **LSCNCOM** will cause ABENDs.

Converting from Cisco IOS for S/390 Release 1.0 to Cisco IOS for S/390 Release 2.0

This section provides information on how to convert your Cisco IOS for S/390 release 1.0 configuration files to the configuration files used for Cisco IOS for S/390 release 2.0. There is also a discussion on the use of the **LOGGING** statement.

Several diagrams are given to show the parameter changes. In the diagrams, parameters not available in Cisco IOS for S/390 release 2.0 are shown crossed out (~~OLDPARAM~~). New parameters are shown in boldface type (**BOLD**).

For complete information on the Cisco IOS for S/390 product, please refer to your documentation set.

This section contains the following topics:

- ACPCFG00 HOST Statement
- Application Statement Mappings
- TCP Protocol Parameters
- UDP Protocol Parameters
- RAW Protocol Parameters
- NETWORK Parameters
- ROUTE Parameters
- Driver Configuration
- IJTCFG00 Changes
- LOGGING Statement

ACPCFG00 HOST Statement

Many of the ACPCFG00 HOST statement parameters were distributed into new and existing configuration files for release 2.0. Parameters that affect applications have been moved to APPCFG00, system parameters have been moved to IJTCFG00, and protocol parameters have been moved to TCPCFG00.

These release 1.0 parameters have been deleted:

- LOGSTAMP
- LOOPBUF
- MVS
- SYSDUMP
- LOOPMTU

Parameters renamed for release 1.0:

- HOST SSN -> GLOBAL API

New statements/parameters for release 2.0:

- SECURITY - SECURITY CLASS, PROFILE, APPLNAME, XSEC
- LOGGING

The following diagram illustrates the changes.

Figure 1 HOST parameters

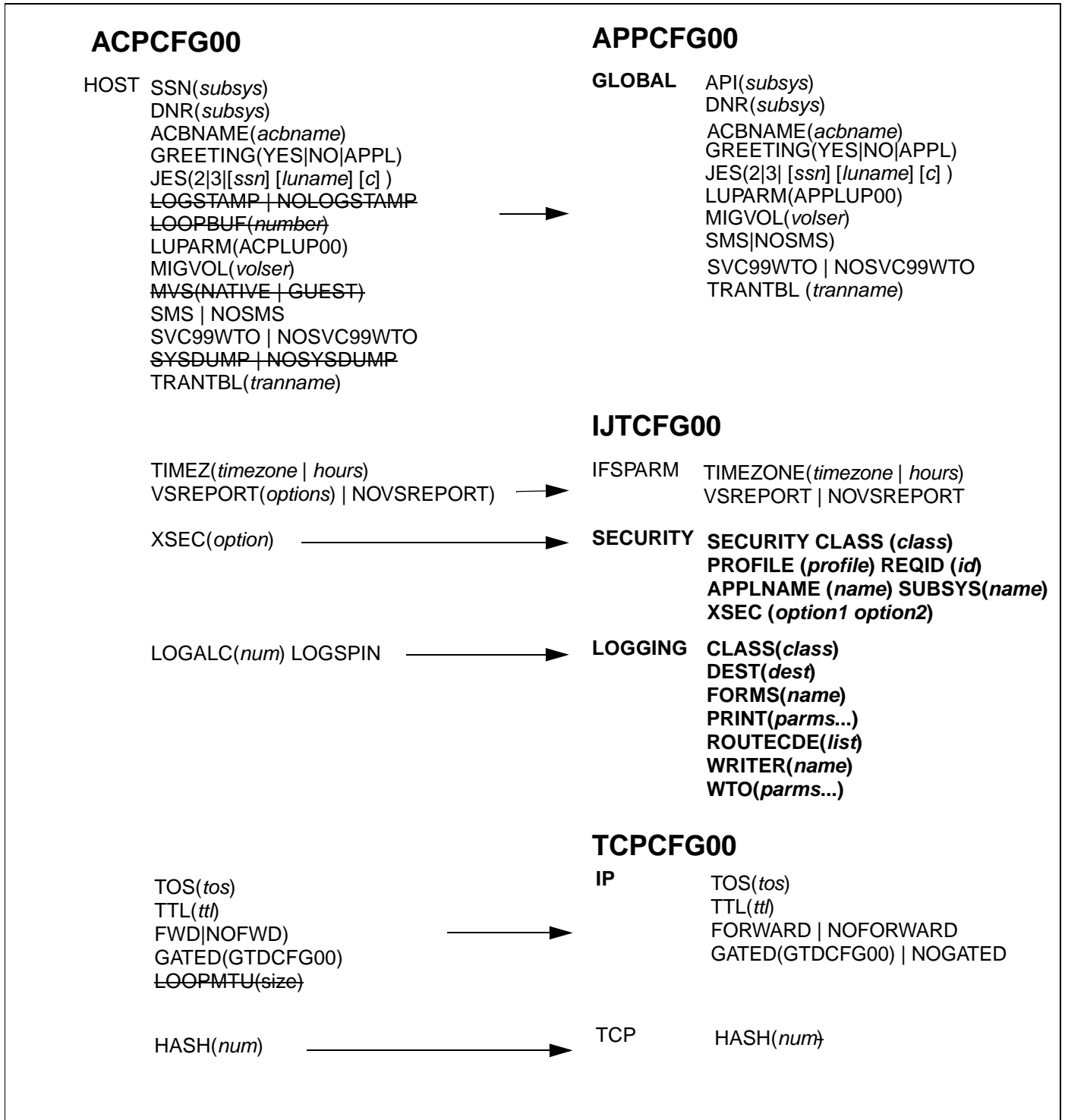

Application Statement Mappings

The application statements in the former ACPCFG00 file can be mapped to the same statements in the APPCFG00 member, although the SMF statement has been moved to IJTCFG00.

These release 1.0 statements have been removed:

- VTAM

New parameters for release 2.0:

- SMF INTERVAL

Figure 2 Application Parameters

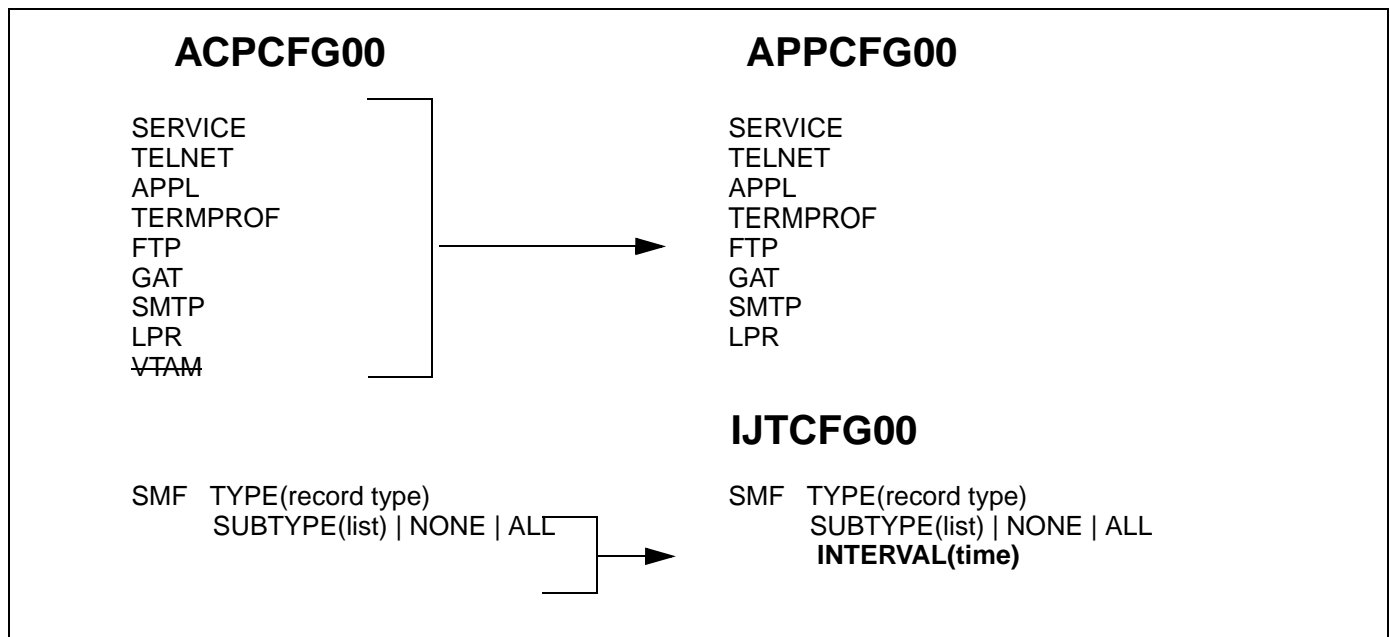

TCP Protocol Parameters

The TIB, TCP and UDP parameters from ACPCFG00 have been moved to TCPCFG00. These parameters are now defined under each protocol, TCP, UDP, IP, and RAW. There was only one parameter name change. TADDRASSIGN and TADDRUSE have been renamed to PORTASSIGN and PORTUSE, respectively. Aliases have been added to support former names, including the TADDRASSIGN and TADDRUSE parameters.

Parameters removed from release 1.0:

- PROTOCOL
- WRELIM
- RABLIM

Parameters renamed for release 1.0:

- TADDRASSIGN -> PORTASSIGN
- TADDRUSE -> PORTUSE

There are new parameters for the TCP statement in release 2.0:

- IPNOTIFY
- KEEPALIVECOUNT
- RTD
- RTO
- TIMEWAIT
- TIMEWAIT

The following diagram shows the parameters.

Figure 3 TCP Parameters

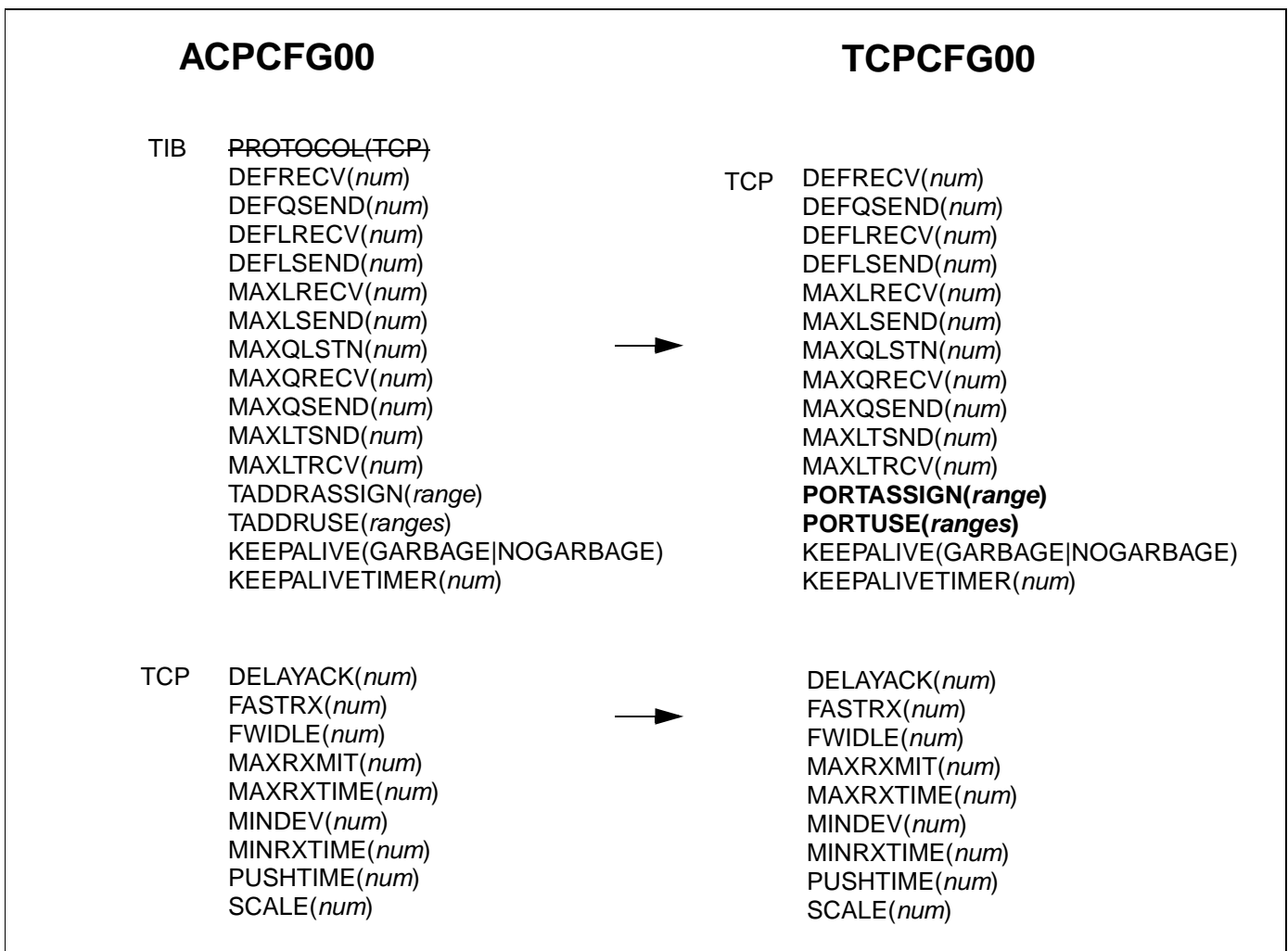

UDP Protocol Parameters

The ACPCFG00 TIB and UDP mappings have been moved to TCPCFG00.

Parameters removed from release 1.0:

- PROTOCOL(UDP)
- UDP IDLE, RABLIM, WRELIM

Parameters renamed for release 1.0:

- TADDRASSIGN -> PORTASSIGN
- TADDRUSE -> PORTUSE

New parameters for release 2.0.

- (None)

Figure 4 UDP Parameters

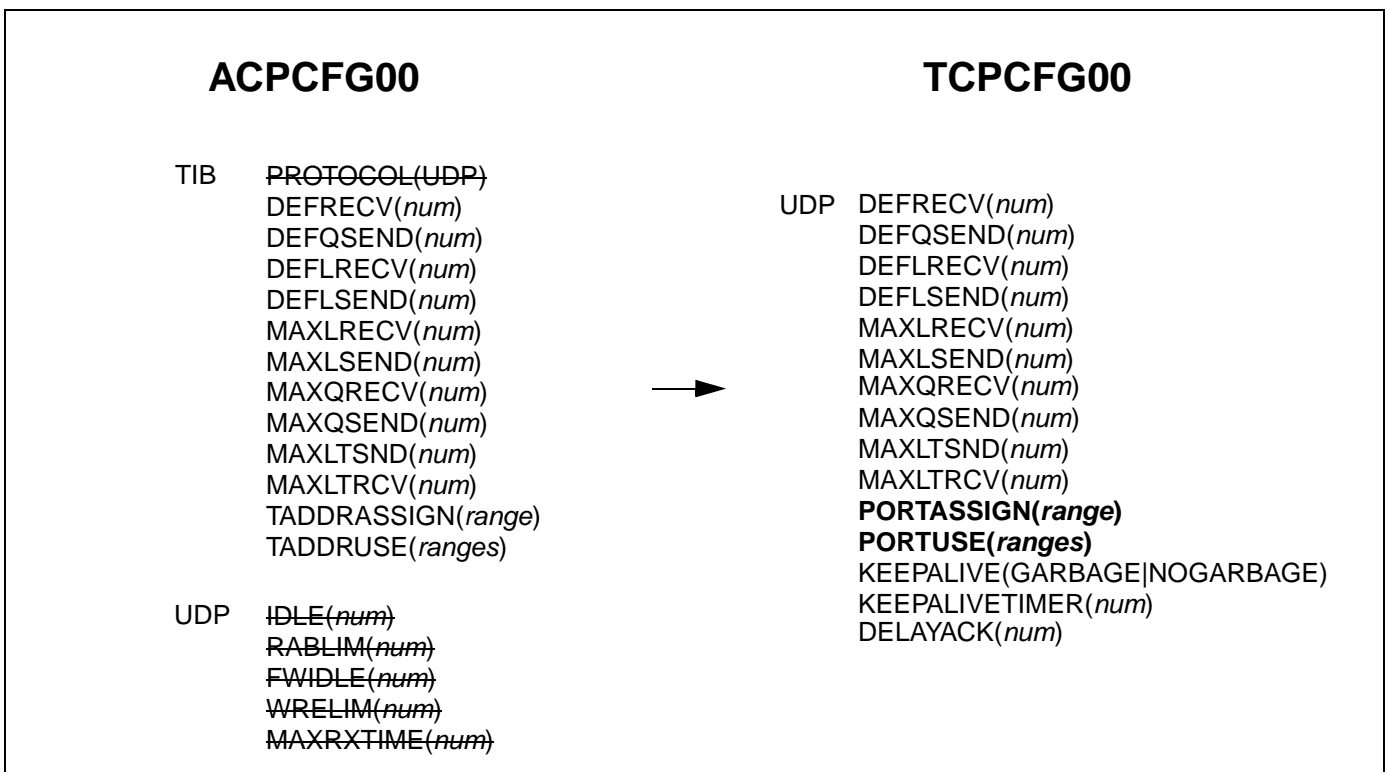

RAW Protocol Parameters

The ACPCFG00 TIB parameters for the RAW protocol have been moved to TCPCFG00.

Parameters removed from release 1.0:

- PROTOCOL(RAW)

Parameters renamed for release 1.0:

- (None)

New parameters for release 2.0.

- (None)

Figure 5 RAW Protocol Parameters

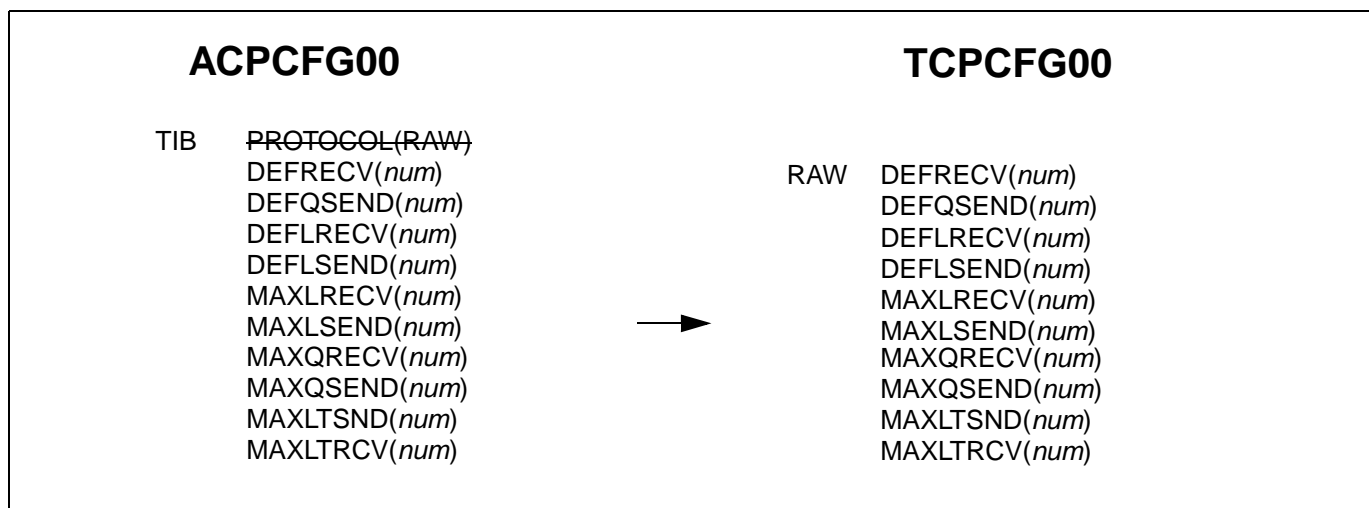

NETWORK Parameters

NETWORK parameters have been moved to TCPCFG00 NETWORK and MEDIA statements.

Parameters removed from release 1.0:

- ARPTABLE
- LNID
- LOOP

Parameters renamed for release 2.0:

- CHECKSUM -> HOSTCKSUM

New parameters for release 2.0.

- MEDIA Statement
- NETWORK MEDIANAME
- NETWORK METRIC

Figure 6 NETWORK Parameters

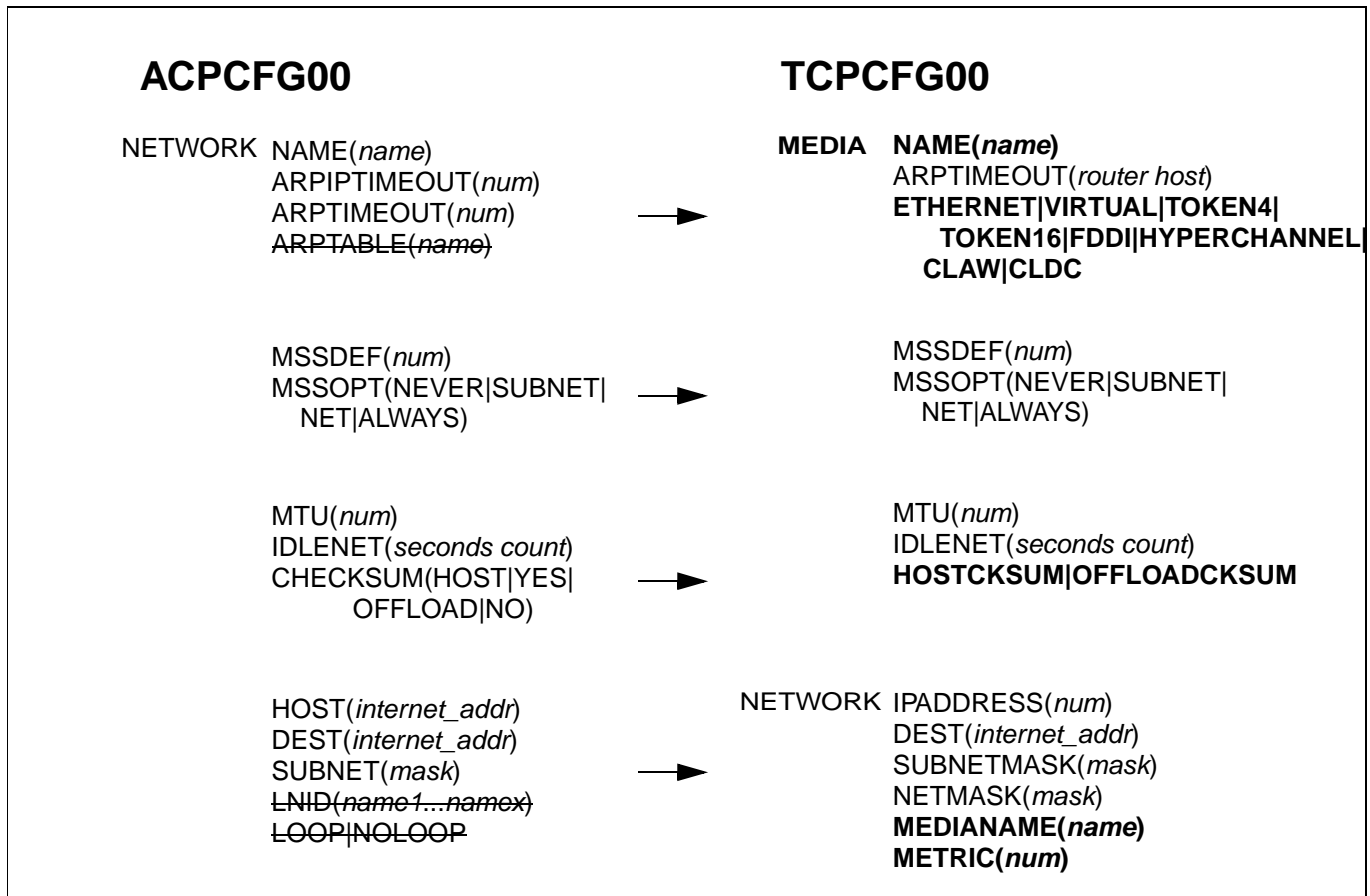

ROUTE Parameters

The following diagram shows the routing statements from Cisco IOS for S/390 release 1.0 and their usage in Cisco IOS for S/390 release 2.0. Most important to notice is that the old ROUTE NET parameter is now a ROUTE MEDIANAME parameter.

Parameters removed from release 1.0:

- NET
- ARPTABLE NAME, TYPE
- ARP FLAGS, MTU, TRUNK, TYPE

Parameters renamed for release 2.0:

- ROUTE -> ROUTER

New parameters for release 2.0.

- ARP MAC, MEDIANAME

Figure 7 ROUTE Parameters

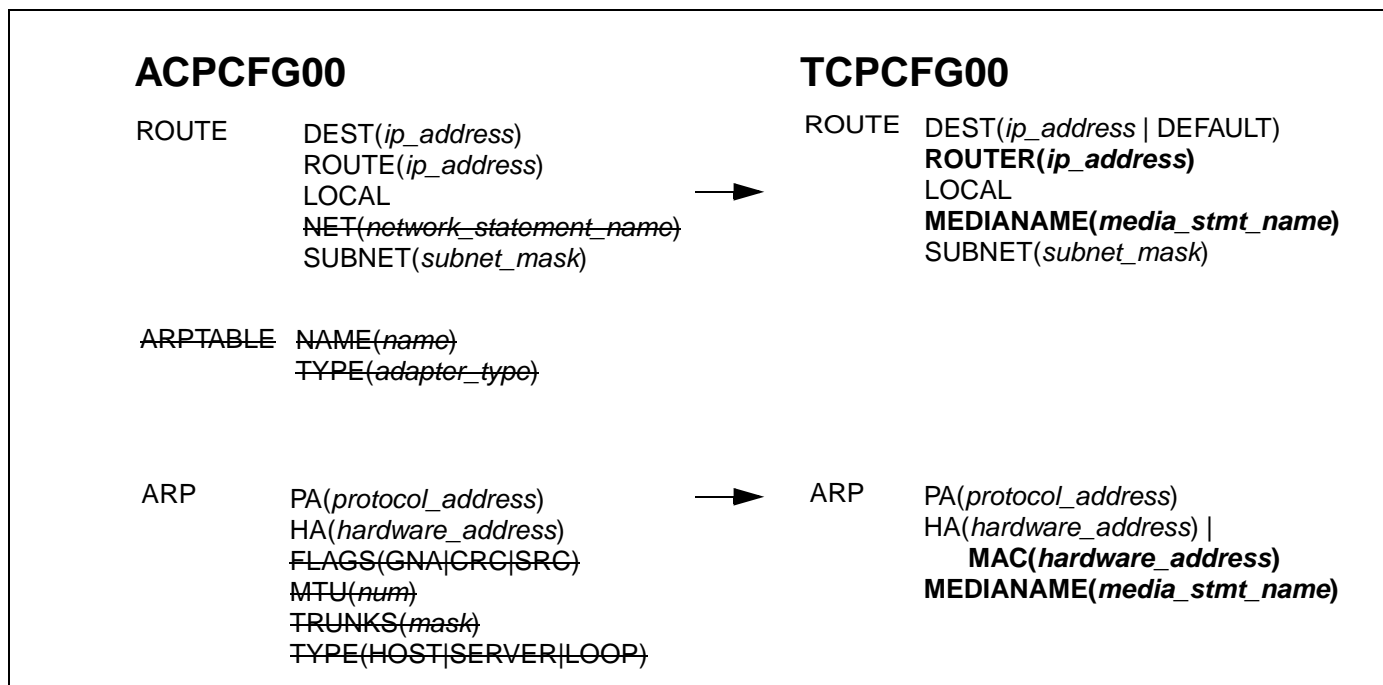

Driver Configuration

Driver configuration has been moved to TCPCFG00.

CETI Driver

CETI driver commands have been moved to TCPCFG00.

Parameters removed from release 1.0:

- LOGOUT
- OPTIONS
- SIDB
- SIDM
- TRACE
- NAME
- ERROR

Parameters changed:

- LNICETI -> CETI
- RETRY has been changed to RESTART

New parameters for release 2.0.

- AUTOSTART
- MEDIANAME

Figure 8 Ceti Driver Parameters

ACPCFG00	→	TCPCFG00
LNICETI CUTYPE(<i>cutype</i>) DEVADDR(<i>ccuu</i>) IBUF(<i>number</i>) IPARM(<i>buf_thresh gat_time</i>) OBUF(<i>number</i>) OPARM(<i>buf_thresh gat_time</i>) RETRY(<i>sec</i>) WTIME(<i>number</i>) LOGOUT(<i>num</i> {SYNC NOSYNC}) OPTIONS((ASYNC SYNC) _____ {DSM ESM} {GETMAIN PCORE} _____ {LOOP NOLOOP} {DOCP EOCP}) SADB(<i>sense_id</i>) SIDM(<i>sense_mask</i>) TRACE NOTRACE NAME(<i>lniname</i>) ERROR{ABEND}		CETI CUTYPE(3752 3762) DEVADDR(<i>ccuu</i>) IBUF(<i>number</i>) IPARM(<i>buf_thresh gat_time</i>) OBUF(<i>number</i>) OPARM(<i>buf_thresh gat_time</i>) RESTART(<i>restart_time</i>) WTIME(<i>number</i>) AUTOSTART NOAUTOSTART MEDIANAME(<i>media_stmt_name</i>)

LNICLAW

ACPCFG00 LNICLAW parameters have been moved to the TCPCFG00 CLAW statement.

Parameters removed from release 1.0:

- TRACE
- NAME
- ERROR

Parameters changed:

- LNICLAW -> CLAW
- RETRY has been changed to RESTART

New parameters for release 2.0.

- PACKED
- MEDIANAME
- New BUFSIZE options have been added
- AUTOSTART

Figure 9 CLAW Driver Parameters

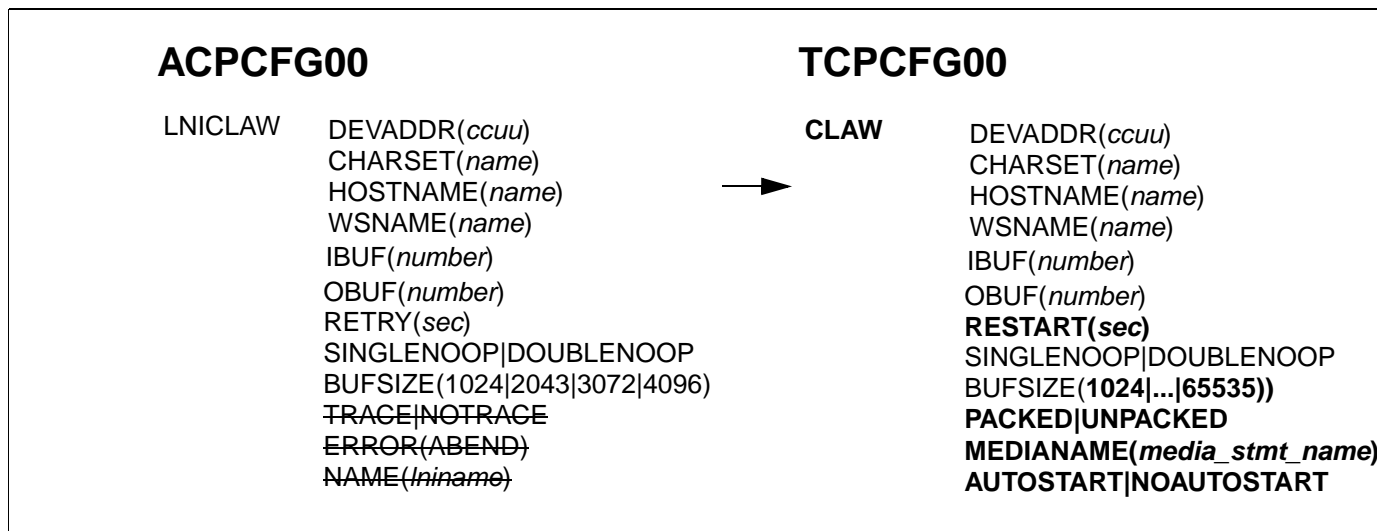

LNICDLC

ACPCFG00 LNICDLC parameters have been moved to the TCPCFG00 CDLC statement.

Parameters removed from release 1.0:

- TRACE
- NAME
- ERROR

Parameters changed:

- LNICDLC -> CDLC
- RETRY has been changed to RESTART

New parameters for release 2.0.

- MEDIANAME
- AUTOSTART

Figure 10 CDLC Driver Parameters

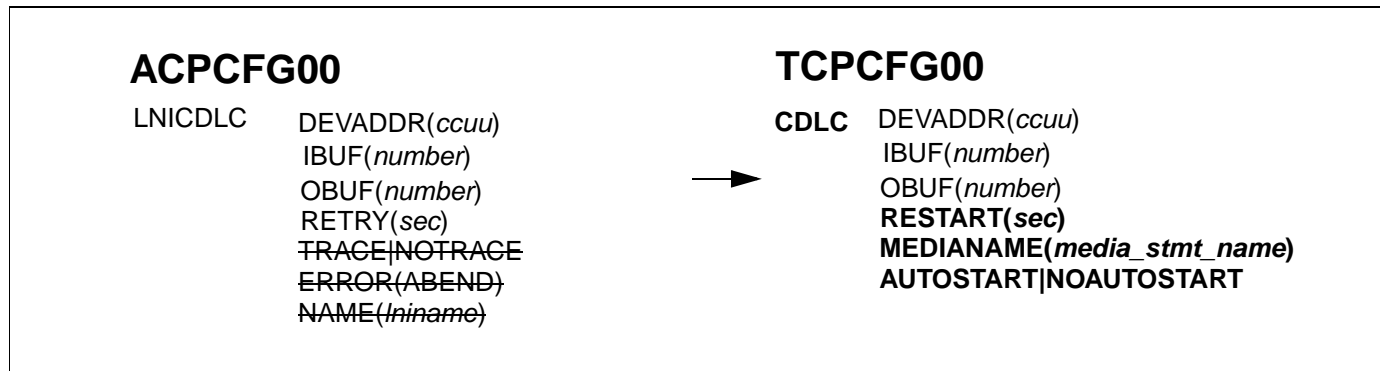
**LNIHYPR**

ACPCFG00 LNIHYPR parameters have been moved to the TCPCFG00 HYPER statement.

Parameters removed from release 1.0:

- TRACE
- NAME
- ERROR

Parameters changed:

- LNIHYPR -> HYPR
- RETRY has been changed to RESTART

New parameters for release 2.0.

- MEDIANAME
- AUTOSTART

Figure 11 HYPR Driver Parameters

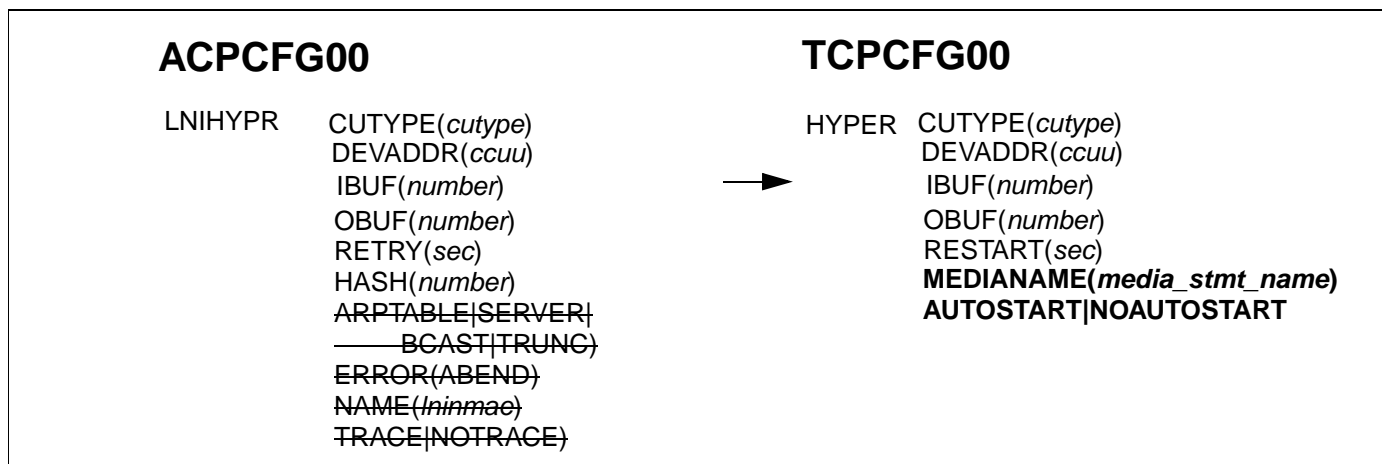

LNILCS and LNILINK

ACPCFG00 LNILCS and LNILINK parameters have been moved to TCPCFG00 LCS and LINK statements.

Parameters removed from release 1.0:

- TRACE
- NAME
- ERROR

Parameters changed:

- LNILCS -> LCS
- LNILINK -> LINK
- LOCLADDR -> LOCALADDR, NOTLADDR -> NOLOCALADDR
- RETRY has been changed to RESTART

New parameters for release 2.0.

- MEDIANAME
- AUTOSTART
- PFILTER
- MEDIA statement parameters ETHERNET|TOKEN4|TOKEN16|FDDI

Figure 12 LCS and LINK Parameters

ACPCFG00			TCPCFG00	
LNILCS	DEVADDR(<i>ccuu</i>) BUFSIZE(<i>number</i>) CUTYPE(<i>type</i>) IBUFFS(<i>number</i>) OBUFFS(<i>number</i>) RETRY(<i>sec</i>) NAME(<i>LCS_stmt_name</i>) NOTLADDR LOCLADDR ERROR(<i>ABEND</i>)	→	LCS	DEVADDR(<i>ccuu</i>) BUFSIZE(<i>number</i>) CUTYPE(<i>type</i>) IBUF(<i>number</i>) OBUF(<i>number</i>) RESTART(<i>sec</i>) NAME(<i>LCS_stmt_name</i>)
			LINK	LOCALADDR NOLOCALADDR
LNILINK	DEVNAME(<i>devname</i>) ADAPTER(<i>number</i>) ALLRT SINGLERT NAME(<i>lniname</i>) TRACE NOTRACE	→	LINK	DEVNAME(<i>devname</i>) ADAPTER(<i>number</i>) ALLRT SINGLERT PFILTER NOPFILTER MEDIANAME(<i>media_stmt_name</i>) AUTOSTART NOAUTOSTART
			MEDIA	ETHERNET TOKEN4 TOKEN16 FDDI

IJTCFG00 Changes

There have been minimal changes to the IJTCFG00 IFSPARM and AUTH statements. The LOGGING statement has been added to IJTCFG00.

Parameters removed from release 1.0:

- (none)

Parameters changed:

- (none)

New parameters for release 2.0.

- LOGGING
- DATASPACE SIZE
- TIMER
- TIMEZONE
- TRACENAME
- VSREPORT

Figure 13 IFSPARM and AUTH Statements

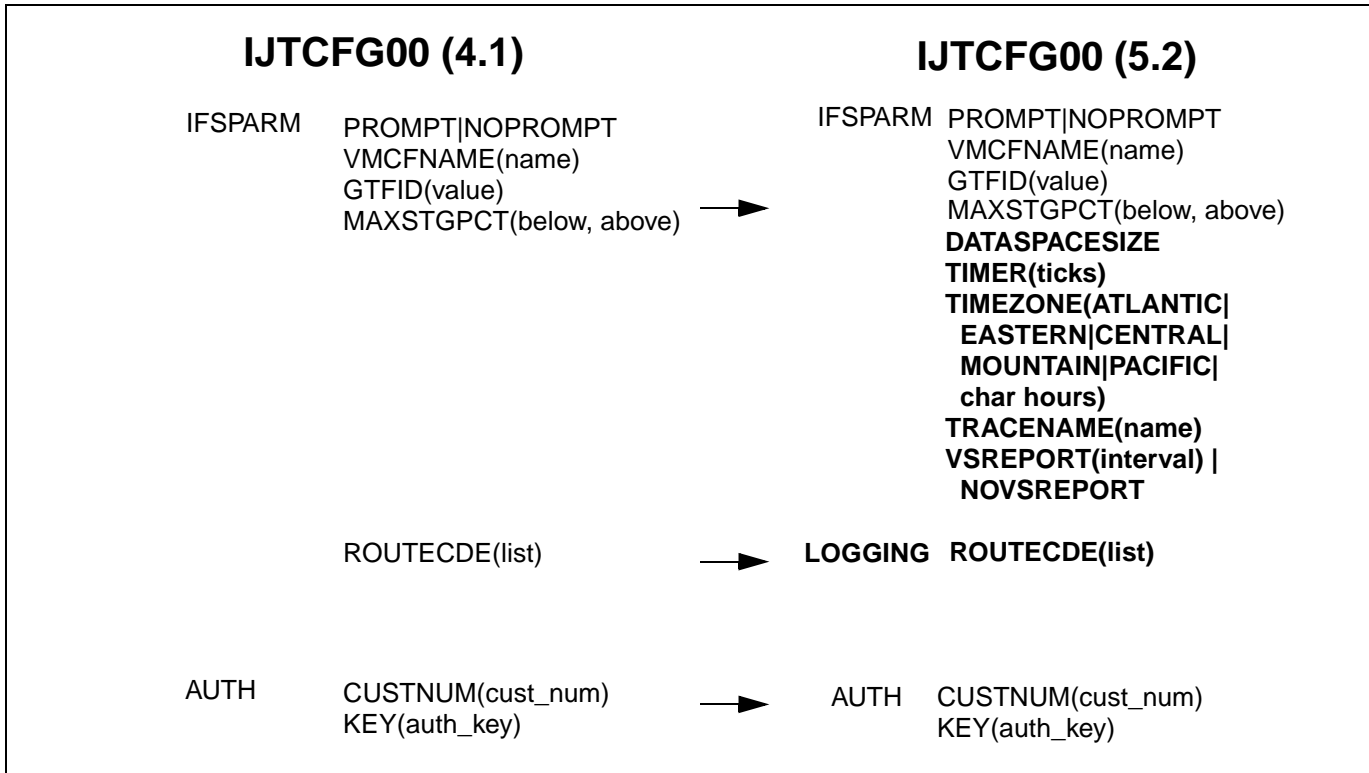

LOGGING Statement

One of the design goals of Cisco IOS for S/390 release 2.0 was to reduce the volume of message output printed. SMF recording was enhanced to allow many of the events previously recorded only by a message to be written to the SMF datasets.

Messages were renumbered so that each message now has a unique prefix, which includes both a severity, and a component code to identify the area of the product which issued the message. The LOGGING statement was added in IJTCFGxx to give you control over which messages will be written to the log or to the console. Message routing can be controlled by severity and component, using the LOGGING statement.

By default, many events previously reported by messages will go unreported in Cisco IOS for S/390 release 2.0. Some customers may prefer to continue seeing the same level of message output as in previous releases of the product. The following LOGGING statement parameters are designed to give a level of event recording reasonably close to what was provided by previous releases of Cisco IOS for S/390:

```
LOGGING PRINT(ALL,(DN,RFEW),(IF,RFEWIS))
WTO((LL,RFEWIS),(CF,RFEWI))
```

You may find that there are other defaults you will wish to change. The LOGGING parameters can be changed dynamically by means of the new LOGGING command, making it easy to experiment with different configurations.

For complete information on the LOGGING statement, and the LOGGING operator command, refer to the Cisco IOS for S/390 documentation.

This document is to be used in conjunction with the Cisco IOS for S/390 publications.

AccessPath, AtmDirector, the CCIE logo, CD-PAC, Centri, the Cisco Capital logo, *CiscoLink*, the Cisco NetWorks logo, the Cisco Powered Network logo, the Cisco Press logo, ClickStart, ControlStream, DAGAZ, Fast Step, FireRunner, IGX, JumpStart, Kernel Proxy, LoopRunner, MGX, Natural Network Viewer, NetRanger, NetSonar, *Packet*, PIX, Point and Click Internetworking, Policy Builder, RouteStream, Secure Script, SMARTnet, SpeedRunner, Stratm, StreamView, *The Cell*, TrafficDirector, TransPath, VirtualStream, VlanDirector, Workgroup Director, and Workgroup Stack are trademarks; Changing the Way We Work, Live, Play, and Learn and Empowering the Internet Generation are service marks; and BPX, Catalyst, Cisco, Cisco IOS, the Cisco IOS logo, Cisco Systems, the Cisco Systems logo, Enterprise/Solver, EtherChannel, FastHub, FastPacket, ForeSight, FragmentFree, IPX, LightStream, MICA, Phase/IP, StrataSphere, StrataView Plus, and SwitchProbe are registered trademarks of Cisco Systems, Inc. in the U.S. and certain other countries. All other trademarks mentioned in this document are the property of their respective owners.

Copyright © 1998, Cisco Systems, Inc.
All rights reserved. Printed in USA.
9810R