



## V.92 Quick Connect for Cisco AS5300 and Cisco AS5800 Universal Access Servers

---

### Feature History

Release	Modification
12.2(2)XA	This feature was introduced on the Cisco AS5350 and Cisco AS5400 running NextPort firmware.  <b>Note</b> As of July 18, 2001, this feature was introduced on the Cisco AS5300 running Cisco MICA Portware Version 2.9.1.0.
12.2(2)XB	This feature was supported with Cisco IOS Release 12.2(2)XB.
12.2(2)XB1	This feature was supported on Cisco AS5800.
12.2(11)T	This feature was integrated into Cisco IOS Release 12.2(11)T and support was added for the Cisco AS5300 and Cisco AS5800 platforms.

This feature module describes the V.92 International Telecommunication Union Telecommunication Standardization Sector (ITU-T) standard Quick Connect (QC) feature with Cisco MICA portware platforms using Cisco IOS Software Releases 12.2(2)XB1 and 12.2(11)T.

This document includes the following sections:

- [Feature Overview, page 2](#)
- [Supported Platforms, page 6](#)
- [Supported Standards, MIBs, and RFCs, page 7](#)
- [Prerequisites, page 7](#)
- [Configuration Tasks, page 7](#)
- [Configuration Examples, page 7](#)
- [Command Reference, page 8](#)
- [Glossary, page 9](#)



# Feature Overview

## V.92

To remain current with industry needs, the ITU-T V.90 modem standard recommendations have been enhanced. The new standard, V.92, meets the need for a digital modem and analog modem pair on the Public Switched Telephone Network (PSTN). V.92 improves the upstream data signaling rate and adds new features that enhance modem usability. These new modem protocols and standards are implemented at the modem level.

This feature module introduces the V.92 [Quick Connect](#) feature on Cisco AS5300 and Cisco AS5800 universal access servers with Cisco MICA Portware Version 2.9.1.0.

**Note**

---

The other feature introduced with the new V.92 standard is V.92 Modem on Hold, which is documented in the *V.92 Modem on Hold for Cisco AS5300 and Cisco AS5800 Universal Access Servers* feature module. V.92 Modem On Hold and V.92 Quick Connect can be enabled independently of each other.

---

V.92 is implemented at the modem level as new modem protocols and standards. The new V.92 features co-reside with existing portware features and have no impact on the hardware configuration of either the Hex Modem Module (HMM) or Double Density Modem Module (DMM), including memory requirements. Cisco IOS software is responsible for controlling the features and displaying the new statistics. V.92 and V.44 support is bound with the rest of the Cisco IOS device driver components.

**Note**

---

V.92 and V.44 are packaged together with Cisco IOS software. For more information about V.44, refer to the *V.44 LZJH Compression for Cisco AS5300 and Cisco AS5800 Universal Access Servers* feature module.

---

**Note**

---

This feature does not support pulse code modulation (PCM) upstream as defined in the V.92 ITU standard. This feature does, however, interoperate with modems that support PCM upstream.

---

## Quick Connect

V.92 Quick Connect speeds up the client-to-server startup negotiation, reducing the overall connect time up to 30 percent. The client modem retains line condition information and characteristics of the connection to the Internet service provider (ISP), which reduces connect time by avoiding some of the initial signal handshaking.

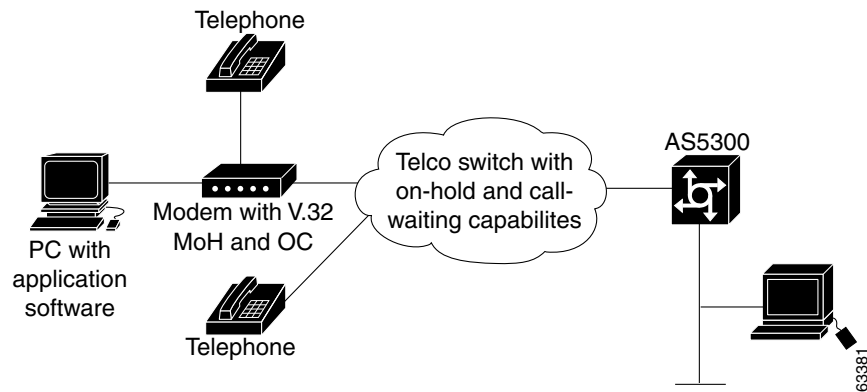

Disconnect reasons and modem states and statistics (link information) have been added or modified to support V.92 Quick Connect. [Table 1](#) lists the new V.92 Quick Connect states, and [Table 2](#) lists the new link information parameters.

**Table 1 Quick Connect States**

Name	Description
Quick Connect	Phase 1 V.92 Quick Connect is being negotiated.
Steady QC	V.92 Quick Connect is being used to reconnect after a V.92 Modem on Hold exchange.
V.8bis Exchange	A V.8bis exchange is taking place.
Ranging	A full phase 2 trainup is taking place.
Ranging Short	A shortened phase 2, using V.92 Quick Connect, is taking place.
Half Duplex Train	Adaptive equalizer training has begun.

**Table 2 Quick Connect Link Information Parameters**

Name	Value
QC Exchange	0: No QC 1: QC Requested 2: QC Short Train Fail 3: QC Full Train Success 4: QC Short Train Success

## AT Commands and S-Registers

V.92 Quick Connect is enabled by default and is controlled with standard **AT** commands and S-registers. S29 is used to enable V.92 sequence detection and S63 is used to enable Quick Connect negotiation, both of which are enabled by default. The S63 S-register controls the feature through the ANSpcm signal.

You can choose the power level of the ANSpcm signal, which defaults to -12dBm (the transmit power level for the United States). The **ATS<sub>n</sub>=v** and **ATS<sub>n</sub>? AT** commands are used to configure V.92 Quick Connect on Cisco MICA platforms.

To disable V.92 Quick Connect or to set a different ANSpcm value, you can use a modemcap (for example, `v92_v44:MSC=s62=8s63=0s21=15s29=12`), or you can set the S29 register to any number other than 12. [Table 3](#) lists the S-registers used to enable and disable the V.92 Quick Connect feature.

**Table 3** Configuring V.92 Quick Connect with S-Registers

Name	Register	Index	Default	Description
V.92 QC Configuration	S63	MICA 64	0x3 QC Enabled ANSpcm Level -12 dBm	Bit 0: QC Enabled 0: Disabled 1: Enabled Bits 1–2 ANSpcm Level 00: -9 dBm 01: -12 dBm 10: -15 dBm 11: -18 dBm
	S29	MICA 19	12 (V.92 enabled)	0 = V.34bis Automode, with V.32ter 1 = V.34bis Automode, without V.32ter 2 = reserved 3 = V.32bis Automode 4 = V.22bis Automode 5 = K56Flex 1.1 Automode 6 = V.90 Automode 7 = MICA:SS7/COT 8 = V.110 9 = Reserved 10 = Reserved 11 = Reserved 12 = V.92 Auto-mode



**Note**

If the V.92 Quick Connect feature is enabled using S29=12, and QC is disabled using S63=0, then the QC Exchange Link Information Parameter is updated to show if QC was requested. However, completely disabling the feature by setting S29 to a value other than 12 disables the reporting of QC requests.

For detailed information about the AT commands and S-registers that are used to configure the V.92 Quick Connect feature on Cisco MICA platforms, refer to the *AT Command Set and Register Summary for MICA 6-Port Modules*.

## Benefits

### Improved Port Use

This feature improves ISP port usage because of the reduction in connect time.

### Standard Modem Feature

V.92 is a standard modem feature that is offered as a no-cost upgrade to the installed system.

## Restrictions

- Configuration of these features using S-registers is carried out by using modemcaps (**AT** commands). Cisco IOS software does not check these values to guarantee that they are valid. The behavior of invalid values is determined by the module.
- Cisco IOS software is packaged as multiple program image types with varying capabilities. Because not all modem interfaces support Quick Connect and because images may be built to support specific modem types, not all software images contain functions to control Quick Connect. In addition, the modems that do support Quick Connect implement their control functions differently. Therefore, registry functions are used to interface between local authorization and Quick Connect control for modems.

## Related Features and Technologies

- V.92 Modem on Hold
- V.44 LZJH data compression service
- Mindspeed CSMv6 hardware solution

## Related Documents

- *AT Command Set and Register Summary for MICA Six-Port Modules*
- *Call Tracker plus ISDN and AAA Enhancements for the Cisco AS5300*
- Cisco AS5300 documentation index
- Cisco AS5800 documentation index
- Cisco IOS Release 12.2 Master Indexes
- *Release Notes for Cisco AS5300 Universal Access Servers, Cisco IOS Release 12.2(2)XA*
- *Release Notes for Cisco AS5300 Universal Access Servers, Cisco IOS Release 12.2(2)XB*
- Cisco IOS Release 12.2T Cross-Platform Release Notes
- Cisco AS5800 Universal Access Server Release Notes
- *Comparing NextPort SPE Commands to MICA Modem Commands*
- *Release Notes for Cisco MICA Portware Version 2.9.1.0 on Cisco AS5300 Universal Access Servers*
- New Features in Release 12.2(2)XB
- *SPE and Firmware Download Enhancements*

- *V.44 LZJH Compression for Cisco AS5300 and Cisco AS5800 Universal Access Servers*
- *V.92 Modem on Hold for Cisco AS5300 and Cisco AS5800 Universal Access Servers*

## Supported Platforms

This feature is supported on the following Cisco platforms:

- Cisco AS5300
- Cisco AS5800

**Table 4** Cisco IOS Release and Platform Support for this Feature

Platform	12.2(2)XA	12.2(2)XB	12.2(2)XB1	12.2(2)XB1
Cisco AS5300	X	X	X	X
Cisco AS5800	Not supported	Not supported	X	X

### Determining Platform Support Through Cisco Feature Navigator

Cisco IOS software is packaged in feature sets that support specific platforms. To get updated information regarding platform support for this feature, access Cisco Feature Navigator. Cisco Feature Navigator dynamically updates the list of supported platforms as new platform support is added for the feature.

Cisco Feature Navigator is a web-based tool that enables you to determine which Cisco IOS software images support a specific set of features and which features are supported in a specific Cisco IOS image. You can search by feature or release. Under the release section, you can compare releases side by side to display both the features unique to each software release and the features in common.

To access Cisco Feature Navigator, you must have an account on Cisco.com. If you have forgotten or lost your account information, send a blank e-mail to [cco-locksmith@cisco.com](mailto:cco-locksmith@cisco.com). An automatic check will verify that your e-mail address is registered with Cisco.com. If the check is successful, account details with a new random password will be e-mailed to you. Qualified users can establish an account on Cisco.com by following the directions at <https://tools.cisco.com/RPF/register/register.do>

Cisco Feature Navigator is updated regularly when major Cisco IOS software releases and technology releases occur. For the most current information, go to the Cisco Feature Navigator home page at the following URL:

<http://www.cisco.com/go/fn>

### Availability of Cisco IOS Software Images

Platform support for particular Cisco IOS software releases is dependent on the availability of the software images for those platforms. Software images for some platforms may be deferred, delayed, or changed without prior notice. For updated information about platform support and availability of software images for each Cisco IOS software release, refer to the online release notes or, if supported, Cisco Feature Navigator.

# Supported Standards, MIBs, and RFCs

## Standards

- V.44
- V.92 Modem on Hold
- V.92 Quick Connect

## MIBs

- CISCO-MODEM-MGMT-MIB
- CISCO-CALL-TRACKER-MODEM-MIB

To locate and download MIBs for selected platforms, Cisco IOS releases, and feature sets, use Cisco MIB Locator found at the following URL:

<http://tools.cisco.com/ITDIT/MIBS/servlet/index>

If Cisco MIB Locator does not support the MIB information that you need, you can also obtain a list of supported MIBs and download MIBs from the Cisco MIBs page at the following URL:

<http://www.cisco.com/public/sw-center/netmgmt/cmtk/mibs.shtml>

To access Cisco MIB Locator, you must have an account on Cisco.com. If you have forgotten or lost your account information, send a blank e-mail to [cco-locksmith@cisco.com](mailto:cco-locksmith@cisco.com). An automatic check will verify that your e-mail address is registered with Cisco.com. If the check is successful, account details with a new random password will be e-mailed to you. Qualified users can establish an account on Cisco.com by following the directions found at this URL:

<http://www.cisco.com/register>

## RFCs

No new or changed RFCs are supported by this feature.

## Prerequisites

- Cisco IOS Release 12.2(2)XA, 12.2(2)XB, or 12.2(11)T
- Basic configuration of the Cisco AS5300 or Cisco AS5800
- Upgraded modem firmware (Cisco MICA portware 2.9.1.0)

## Configuration Tasks

None

## Configuration Examples

None

# Command Reference

This feature uses no new or modified commands. For information about all Cisco IOS commands, go to the Command Lookup Tool at <http://tools.cisco.com/Support/CLILookup> or to the *Cisco IOS Master Commands List*.

Also see the following documentation for further information about V.92 and V.44 using Cisco MICA technology:

- *V.44 LZJH Compression for Cisco AS5300 and Cisco AS5800 Universal Access Servers*
- *V.92 Modem on Hold for Cisco AS5300 and Cisco AS5800 Universal Access Servers*



# Glossary

**CLI**—command-line interface.

**CSMv6**—Mindspeed modem hardware solution.

**CSR**—call success rate.

**DFC**—dial feature card.

**DSP**—Digital Signal Processor. Microprocessor on which the modulation/demodulation process is carried out.

**ISP**—Internet service provider.

**ITU-T**—International Telecommunication Union Telecommunication Standardization Sector.

**LZJH**—Lempel-Ziv-Jeff-Heath data compression algorithm used in V.44.

**MICA**—Multi-service IOS Channel Aggregation. Used as a generic term to describe the Dial Technology Division (DTD) high density modem technology.

**MOH**—Modem on Hold functionality specified in V.92.

**NextPort**—Device driver architecture for Cisco IOS software that supports the NextPort hardware and software interfaces. Supports the universal port concept.

**PCM**—pulse code modulation.

**PSTN**—Public Switched Telephone Network.

**RADIUS**—Remote Dial-In User Service. Database for authenticating modem and ISDN connections and for tracking connection time.

**SPE**—service processing element.

**QC**—Quick Connect functionality specified in V.92

**universal port**—Concept of a single device that can terminate one digital signaling level zero (DS0) with a data modem, fax modem, ISDN, or voice solution.

**V.44**—ITU modem standard for LZJH data compression algorithm.

**V.92**—ITU modem standard that contains Quick Connect, Modem On Hold, and PCM upstream.

**VSA**—vendor specific attribute (as used with RADIUS).

---

Cisco and the Cisco logo are trademarks or registered trademarks of Cisco and/or its affiliates in the U.S. and other countries. To view a list of Cisco trademarks, go to this URL: [www.cisco.com/go/trademarks](http://www.cisco.com/go/trademarks). Third-party trademarks mentioned are the property of their respective owners. The use of the word partner does not imply a partnership relationship between Cisco and any other company. (1110R)

Any Internet Protocol (IP) addresses and phone numbers used in this document are not intended to be actual addresses and phone numbers. Any examples, command display output, network topology diagrams, and other figures included in the document are shown for illustrative purposes only. Any use of actual IP addresses or phone numbers in illustrative content is unintentional and coincidental.

© 2001–2009 Cisco Systems, Inc. All rights reserved.