



802.1ah Support for Ethernet Infrastructure

First Published: November 20, 2009

Last Updated: November 20, 2009

The Excalibur MAC Tunneling Protocol (MTP) feature is based on IEEE 802.1ah standard and provides Virtual Bridged Local Area Network (VLAN) and MAC scalability. This feature extends the Cisco QinQ (IEEE 802.1ad) capability to support highly scalable Provider Backbone Bridge Architecture (PBB). MTP allows a service provider to interconnect multiple Provider Bridged Networks (PBNs) with maximum 10,48,576 (2 to the 20th power) Service VLANS support and extend the MAC address scalability.

Finding Feature Information

Your software release may not support all the features documented in this module. For the latest feature information and caveats, see the release notes for your platform and software release. To find information about the features documented in this module, and to see a list of the releases in which each feature is supported, see the “[Feature Information for 802.1ah Support for Ethernet Infrastructure](#)” section on [page 11](#).

Use Cisco Feature Navigator to find information about platform support and Cisco IOS and Catalyst OS software image support. To access Cisco Feature Navigator, go to <http://www.cisco.com/go/cfn>. An account on Cisco.com is not required.

Contents

- [Information About 802.1ah Support for Ethernet Infrastructure](#), page 2
- [How to Configure 802.1ah Support for Ethernet Infrastructure](#), page 5
- [Configuration Examples for 802.1ah Support for Ethernet Infrastructure](#), page 8
- [Additional References](#), page 9
- [Feature Information for 802.1ah Support for Ethernet Infrastructure](#), page 11



Americas Headquarters:

Cisco Systems, Inc., 170 West Tasman Drive, San Jose, CA 95134-1706 USA

Information About 802.1ah Support for Ethernet Infrastructure

With this feature, you can scale a Provider Bridged P802.1ad network using the existing Bridged and VLAN deployment. Although the current Cisco QinQ capability provides for VLAN scaling, this feature extends the scaling and inter-operability between multiple vendors.

To make forwarding decisions, Bridges in a Provider Backbone Bridged Network (PBBN) need to learn MAC address of each host. MTP resolves the issue of MAC address learning by encapsulating the data packet and MAC addresses (source and destination) into a new Ethernet frame. The header of the new Ethernet frame contains:

- Destination Backbone MAC (B-MAC)
- Source Backbone MAC (B-MAC)
- Backbone VLAN TAG (B-TAG) with 12 bit Backbone VLAN ID (B-VID)
- Service Instance TAG (I-TAG) with 24 bit Service Instance ID (I-SID)

MAC scalability is implemented using the B-MACs. Since the new Ethernet frames are encapsulated with MAC address while traversing the PBBN, a bridge needs to learn only the B-MACs. The MAC addresses of hosts are hidden from the Provider Backbone Bridges (PBB), resulting in the PB Bridges to learn only the provider MAC address, independent of the number of hosts or the number of host MAC addresses supported. Since the data packets are sent to specific MAC addresses, the 802.1ah cloud is not flooded with unnecessary traffic. A MAC address may be a static entry in the MAC address table on the Backbone Core Bridge.

The VLAN scalability is implemented using the I-SID. The MTP achieves VLAN scalability by using a backbone VLAN TAG with 12 bit B-VID and the Service Instance TAG with 24 bit Service Instance ID to provide the VLAN scalability necessary to map large number of customers.

MTP Software Architecture

The encapsulation and de-capsulation of MAC addresses is performed on a Backbone Edge Bridge (BEB) at the edge of the PBBN. A BEB can be an I-Bridge (I-BEB), a B-bridge (B-BEB), or an IB-bridge (IB-BEB). MTP with IB-BEB functionality is also supported. [Figure 1](#) shows the MTP software architecture:

Figure 1 MTP Software Architecture

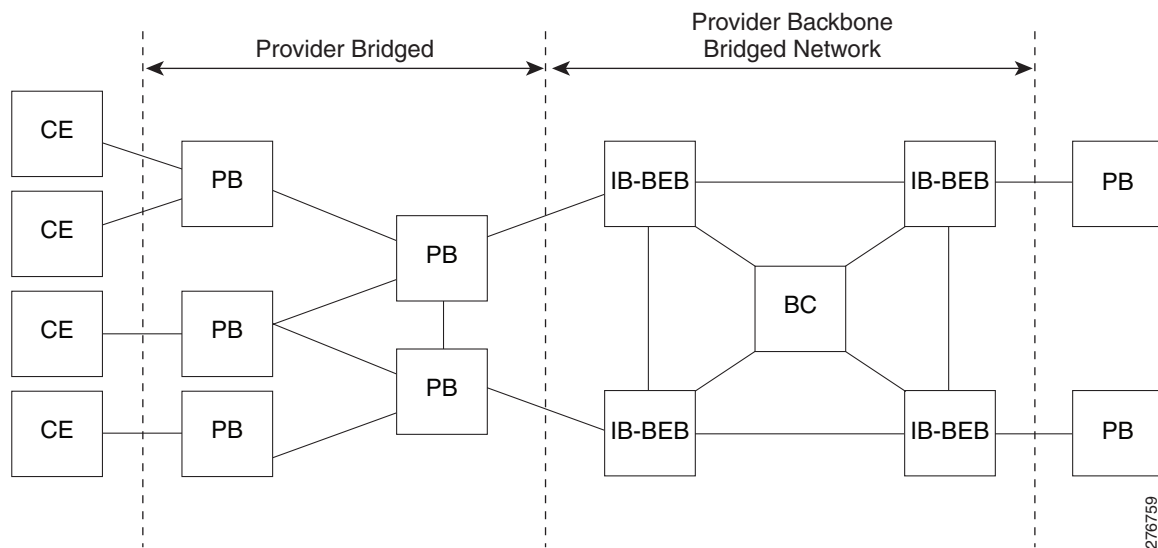

IB Backbone Edge Bridge

The IB-BEB consists of one B-Component and one or more I-Components. An IB-BEB provides the functionality to select the B-MAC and insert I-SIDs based on the supported tags. It also validates the I-SIDs and transmits or receives the frames on the B-VLAN.

The 802.1ah draft describes two types of customer facing interfaces supported by IB-BEB:

- S-Tagged Service Interface
 - Translating S-tagged Interface
 - Bundling S-tagged interface
- Port Based (transparent) Service Interface

MTP supports these interfaces.

Data Plane Processing

The packets on the ingress EFP are tunneled to the appropriate MAC tunnel using the C-MAC bridge domain. For multiple EFPs using the same I-SID, the switching among EFPs is done using the C-MAC bridge domain. The local switching is performed across all the ports in the bridge domain even if they span multiple tunnel engines.

MTP Configuration

[Table 1](#) lists the relationship between the various entities in a Cisco 7600 Series router for MTP implementation:

Table 1 Relationship between the various entities in a Cisco 7600 Series Router

Entity to Entity	Relationship
EFP to C-MAC bridge domain	many to one
C-MAC bridge domain to I-SID	one to one
I-SID to B-MAC bridge domain	many to one

Figure 2 show N to N relationship within a Cisco 7600 Series Router:

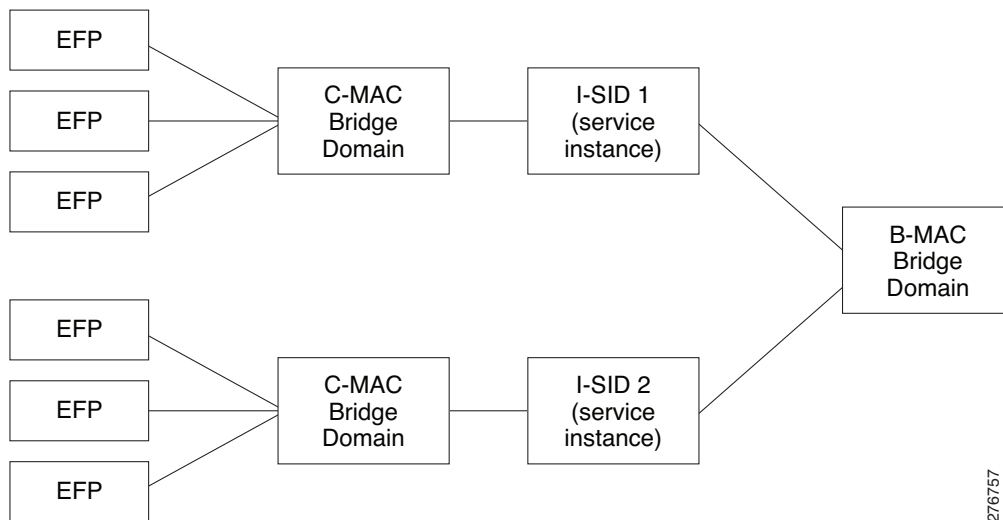
Figure 2 N to N relationship within a Cisco 7600 Series Router

Scalability Information

Table 2 lists the scalability information for MTP:

Table 2 Scalability Information for MTP

Scalability Factor	Scalability Number
Total number of EVCs in the system	32000
Total number of EVCs per line card	16000
Total number of ISIDs in the system	
Total C-MAC addresses per LC	128000 (32000 per NPU)
Total number of EVCs per ISID per NPU	110
Total number of EVCs per ISID for a two port Excalibur	220
Total number of EVCs per ISID for a four port Excalibur	440
Total B-bridge-domains per chassis	4094

Scalability Factor	Scalability Number
Total I-SIDs or MAC-Tunnels	16000
Total entries in a C-MAC table	32000

How to Configure 802.1ah Support for Ethernet Infrastructure

The configuration of 802.1ah support for ethernet infrastructure of Excalibur MTP for Cisco 7600 Router is described in detail below.

Restrictions

Follow these restrictions and usage guidelines when configuring the MAC Tunneling Protocol on an ES40 line card:

- By default, all the BPDUs are dropped.
- The Port channels with 802.1ah EVCs are supported. However, there can only be one member link per port channel.
- The IGMP Snooping or any multicast protocol support on the C bridge-domain.
- The MAC address synchronization and MAC address move notification in the C bridge-domain is not supported.
- The DHCP Snooping with 802.1ah EVCs is not supported.
- The B-Bridge and I-Bridge models are not supported.
- An ISID configured under a MAC-Tunnel cannot be configured on another MAC-Tunnel.
- The tunnel-engine configuration is not supported.
- Source MAC address configuration for a Tunnel-Engine is not supported.

SUMMARY STEPS

1. **enable**
2. **configure terminal**
3. **interface gigabitEthernet *slot/port* or interface tengigabitEthernet *slot/port***
4. **service instance *id* {Ethernet [*service-name*]}**
5. **encapsulation untagged dot1q {*any* | *vlan-id*[*vlan-id*]*vlan-id*} second-dot1q {*any* | *vlan-id*[*vlan-id*]*vlan-id*]}**
6. **rewrite ingress tag {push {dot1q *vlan-id* | dot1q *vlan-id* second-dot1q *vlan-id* | dot1ad *vlan-id* dot1q *vlan-id*} | pop {1 | 2} | translate {1-to-1 {dot1q *vlan-id* | dot1ad *vlan-id*} | 2-to-1 dot1q *vlan-id* | dot1ad *vlan-id*} | 1-to-2 {dot1q *vlan-id* second-dot1q *vlan-id* | dot1ad *vlan-id* dot1q *vlan-id*} | 2-to-2 {dot1q *vlan-id* second-dot1q *vlan-id* | dot1ad *vlan-id* dot1q *vlan-id*}} [symmetric]**
7. **bridge-domain bridge-id c-mac**
8. **exit**
9. **exit**
10. **ethernet mac-tunnel virtual *mac-in-mac-tunnel-identifier***
11. **bridge-domain bridge-id**

12. **service instance id {Ethernet [service-name]}**
13. **encapsulation dot1ah i-sid i-sid_number**
14. **bridge-domain bridge-id c-mac**
15. **exit**
16. **exit**
17. **exit**

DETAILED STEPS

	Command or Action	Purpose
Step 1	<pre>enable</pre> <p>Example: Router> enable</p>	<p>Enables privileged EXEC mode.</p> <ul style="list-style-type: none"> Enter your password if prompted.
Step 2	<pre>configure terminal</pre> <p>Example: Router# configure terminal</p>	<p>Enters global configuration mode.</p>
Step 3	<pre>interface gigabitEthernet slot/port or interface tengigabitEthernet slot/port</pre> <p>Example: Router(config)#interface GigabitEthernet 3/1</p>	<p>Specifies the Gigabit Ethernet interface to be configured, where:</p> <ul style="list-style-type: none"> <i>slot/port</i>—Specifies the location of the interface
Step 4	<pre>service instance id {Ethernet [service-name]}</pre> <p>Example: Router(config-if)#service instance 20 ethernet</p>	<p>Creates a service instance (an instance of an EVC) on an interface and sets the device into the config-if-srv mode.</p>
Step 5	<pre>encapsulation untagged dot1q {any vlan-id[vlan-id[vlan-id]]} second-dot1q {any vlan-id[vlan-id[vlan-id]]}</pre> <p>Example: Router(config-if-srv)#encapsulation dot1q 40 second-dot1q 42</p>	<p>Configures the encapsulation. Defines the matching criteria to be used in order to map ingress dot1q frames on an interface to the appropriate service instance.</p>
Step 6	<pre>rewrite ingress tag {push {dot1q vlan-id dot1q vlan-id second-dot1q vlan-id dot1ad vlan-id dot1q vlan-id} pop {1 2} translate {1-to-1 {dot1q vlan-id dot1ad vlan-id} 2-to-1 dot1q vlan-id dot1ad vlan-id} 1-to-2 {dot1q vlan-id second-dot1q vlan-id dot1ad vlan-id dot1q vlan-id} 2-to-2 {dot1q vlan-id second-dot1q vlan-id dot1ad vlan-id dot1q vlan-id}} [symmetric] [no] bridge-domain bridge-id c-mac</pre> <p>Example: Router(config-if-srv)#rewrite ingress tag pop 1 symmetric</p>	<p>Specifies the tag manipulation that is to be performed on the frame ingress to the service instance.</p>

	Command or Action	Purpose
Step 7	<code>bridge-domain bridge-id c-mac</code> Example: Router(config-if-srv)# <code>bridge-domain 21 c-mac</code>	Configuring the bridge domain. Binds the service instance to a bridge domain instance where bridge-id is the identifier for the bridge domain instance.
Step 8	<code>exit</code> Example: Router(config-if-srv)# <code>exit</code>	Exits the service instance mode.
Step 9	<code>exit</code> Example: Router(config-if)# <code>exit</code>	Exits the interface mode.
Step 10	<code>ethernet mac-tunnel virtual mac-in-mac-tunnel-identifier</code> Example: Router(config)# <code>ethernet mac-tunnel virtual 22</code>	Configures mac-in-mac tunnel and creates a tunnel identifier for the 802.1ah cloud. Sets the configuration to config-tunnel-minm mode.
Step 11	<code>bridge-domain bridge-id</code> Example: Router(config-tunnel-minm)# <code>bridge-domain 200</code>	Binds the mac tunnel to the B-MAC bride domain instance.
Step 12	<code>service instance id {Ethernet [service-name]}</code> Example: Router(config-tunnel-minm)# <code>service in 23 ethernet</code>	Defines the service instance to be used with B-VLAN. Set the configuration mode to config-tunnel-srv mode.
Step 13	<code>encapsulation dot1ah i-sid i-sid_number</code> Example: Router(config-tunnel-srv)# <code>encapsulation dot1ah isis 24</code>	Defines the matching criteria to be used to map 802.1ah frames with I-SID id to the appropriate EVC.
Step 14	<code>bridge-domain bridge-id c-mac</code> Example: Router(config-tunnel-srv)# <code>bridge-domain 21 c-mac</code>	Maps the I-SID used for forwarding the customer packets to a specific EVC on the interface. The bridge-id mentioned step 7 must match with bridge-id in this step to ensure proper configuration.
Step 15	<code>exit</code> Example: Router(config-tunnel-srv)# <code>exit</code>	Exits the mac-tunnel service instance mode.

	Command or Action	Purpose
Step 16	<code>exit</code> Example: Router(config-tunnel-minm)# <code>exit</code>	Exits the mac-tunnel mode.
Step 17	<code>exit</code> Example: Router(config)# <code>exit</code>	Exits the global config mode.

Configuration Examples for 802.1ah Support for Ethernet Infrastructure

This example shows how to configure Excalibur MTP for Cisco 7600 Routers:

```
Router>enable
Router#configure terminal
Router(config)#interface GigabitEthernet 3/1
Router(config-if)#service instance 20 ethernet
Router(config-if-srv)#encapsulation dot1q 40 second-dot1q 42
Router(config-if-srv)#rewrite ingress tag pop 1 symmetric
Router(config-if-srv)#bridge-domain 21 c-mac
Router(config-if-srv)#exit
Router(config-if)#exit
Router(config)#ethernet mac-tunnel virtual 22
Router(config-tunnel-minm)#bridge-domain 200
Router(config-tunnel-minm)#service in 23 ethernet
Router(config-tunnel-srv)#encapsulation dot1ah isid 24
Router(config-tunnel-srv)#bridge-domain 21 c-mac
Router(config-tunnel-srv)#exit
Router(config-tunnel-minm)#exit
Router(config)#exit
```

Use the following commands to verify the MTP configuration:

- You can use the **show platform mtp slot *slot_num*** command to verify the MTP configuration. This command shows the information about MTP for each slot:

```
Router#sh platform mtp slot 3
SLOT      TUNNELENGINE      VLAN_LIST
 3         MacTunnelEngine3/0  200
 3         MacTunnelEngine3/1
 3         MacTunnelEngine3/2
 3         MacTunnelEngine3/3
```

- You can use **show platform mtp c_bd *c-vlan-id*** to view information about a specific C-VLAN:

```
Router#sh platform mtp c_bd 21
C_BD      B_BD      SLOT      PPE      C_BD_COUNT
 21       200       3         0         1
Router#
```

- You can use **show platform mtp b_bd *b-vlan-id*** to view information about a specific B-VLAN:

```
Router#sh platform mtp b_bd 200
B_BD      SLOT      PPE      B_BD_COUNT
 200       3         0         1
Router#
```

- You can use **show platform mtp befp** *b-efp-id* to view information about a specific B-EFP:

```
Router#sh platform mtp befp 23
BEFP      C_BD      B_BD      SLOT      PPE      C_BD_COUNT
23        21         200       3         0        1
Router#
```

- You can use **show ethernet service mac-tunnel summary** to view a summary of information about a specific mac tunnel.
- You can use **show ethernet service mac-tunnel** *id* [**detail**] to view information about a specific mac tunnel, and the ID can range from 1 to 4094.

```
Router#show ethernet service mac-tunnel 1 detail
Tunnel Id: 1
EFP Microblocks:
*****
Microblock type: Bridge-domain
Bridge-domain: 20

No. of Service Instances: 1

Service Instance ID: 16000
Associated Tunnel Id: 1
Encapsulation: dot1ah 1 vlan-type 0x88E7
Rewrite: egress tag push dot1ah 1 vlan-type 0x88E7 symmetric
State: Up
mac-tunnel address map: 0001.0001.0001 0002.0002.0002
EFP Statistics:
  Pkts In  Bytes In  Pkts Out  Bytes Out
      0      0         0         0
EFP Microblocks:
*****
Microblock type: Bridge-domain
Bridge-domain: 1 c-mac

Microblock type: CFM
CFM encapsulation:
```

Additional References

The following sections provide references related to the IEEE 802.1ah Support for Ethernet Infrastructure feature.

Related Documents

Related Topic	Document Title
Configuring ATM	Configuring ATM
ATM commands	Cisco IOS Asynchronous Transfer Mode Command Reference

Standards

Standard	Title
No new or modified standards are supported by this feature.	—

MIBs

MIB	MIBs Link
<ul style="list-style-type: none"> None. 	<p>To locate and download MIBs for selected platforms, Cisco IOS releases, and feature sets, use Cisco MIB Locator found at the following URL:</p> <p>http://www.cisco.com/go/mibs</p>

RFCs

RFC	Title
No new or modified RFCs are supported by this feature.	—

Technical Assistance

Description	Link
<p>The Cisco Support website provides extensive online resources, including documentation and tools for troubleshooting and resolving technical issues with Cisco products and technologies.</p> <p>To receive security and technical information about your products, you can subscribe to various services, such as the Product Alert Tool (accessed from Field Notices), the Cisco Technical Services Newsletter, and Really Simple Syndication (RSS) Feeds.</p> <p>Access to most tools on the Cisco Support website requires a Cisco.com user ID and password.</p>	<p>http://www.cisco.com/techsupport</p>

Feature Information for 802.1ah Support for Ethernet Infrastructure

Table 3 lists the release history for this feature.

Not all commands may be available in your Cisco IOS software release. For release information about a specific command, see the command reference documentation.

Use Cisco Feature Navigator to find information about platform support and software image support. Cisco Feature Navigator enables you to determine which Cisco IOS and Catalyst OS software images support a specific software release, feature set, or platform. To access Cisco Feature Navigator, go to <http://www.cisco.com/go/cfn>. An account on Cisco.com is not required.



Note

Table 3 lists only the Cisco IOS software release that introduced support for a given feature in a given Cisco IOS software release train. Unless noted otherwise, subsequent releases of that Cisco IOS software release train also support that feature.

Table 3 Feature Information for 802.1ah Support for Ethernet Infrastructure

Feature Name	Releases	Feature Information
802.1ah Support for Ethernet Infrastructure	12.2(33)SRE	<p>The Excalibur MAC Tunneling Protocol (MTP) feature is based on 802.1ah standard and provides VLAN and MAC scalability. This feature extends the Cisco QinQ (IEEE 802.1ad) capability to support highly scalable PBA.</p> <p>In 12.2(33)SRE, this feature was introduced on the Cisco 7600.</p> <p>The following commands were introduced or modified: service instance id, encapsulation untagged dot1q, rewrite ingress tag, bridge-domain bridge-id c-mac, ethernet mac-tunnel virtual, encapsulation dot1ah, bridge-domain bridge-id c-mac, show ethernet service mac-tunnel.</p>

CCDE, CCENT, CCSI, Cisco Eos, Cisco HealthPresence, Cisco IronPort, the Cisco logo, Cisco Nurse Connect, Cisco Pulse, Cisco SensorBase, Cisco StackPower, Cisco StadiumVision, Cisco TelePresence, Cisco Unified Computing System, Cisco WebEx, DCE, Flip Channels, Flip for Good, Flip Mino, Flipshare (Design), Flip Ultra, Flip Video, Flip Video (Design), Instant Broadband, and Welcome to the Human Network are trademarks; Changing the Way We Work, Live, Play, and Learn, Cisco Capital, Cisco Capital (Design), Cisco:Financed (Stylized), Cisco Store, Flip Gift Card, and One Million Acts of Green are service marks; and Access Registrar, Aironet, AllTouch, AsyncOS, Bringing the Meeting To You, Catalyst, CCDA, CCDP, CCIE, CCIP, CCNA, CCNP, CCSP, CCVP, Cisco, the Cisco Certified Internetwork Expert logo, Cisco IOS, Cisco Lumin, Cisco Nexus, Cisco Press, Cisco Systems, Cisco Systems Capital, the Cisco Systems logo, Cisco Unity, Collaboration Without Limitation, Continuum, EtherFast, EtherSwitch, Event Center, Explorer, Follow Me Browsing, GainMaker, iLYNX, IOS, iPhone, IronPort, the IronPort logo, Laser Link, LightStream, Linksys, MeetingPlace, MeetingPlace Chime Sound, MGX, Networkers, Networking Academy, PCNow, PIX, PowerKEY, PowerPanels, PowerTV, PowerTV (Design), PowerVu, Prisma, ProConnect, ROSA, SenderBase, SMARTnet, Spectrum Expert, StackWise, WebEx, and the WebEx logo are registered trademarks of Cisco Systems, Inc. and/or its affiliates in the United States and certain other countries.

All other trademarks mentioned in this document or website are the property of their respective owners. The use of the word partner does not imply a partnership relationship between Cisco and any other company. (0910R)

Any Internet Protocol (IP) addresses and phone numbers used in this document are not intended to be actual addresses and phone numbers. Any examples, command display output, network topology diagrams, and other figures included in the document are shown for illustrative purposes only. Any use of actual IP addresses or phone numbers in illustrative content is unintentional and coincidental.

© 2009 Cisco Systems, Inc. All rights reserved.