



L2VPN Interworking

First Published: August 26, 2003

Last Updated: November 17, 2006

This feature module explains how to configure the following Layer 2 Virtual Private Network (L2VPN) Interworking features:

- Ethernet/VLAN to ATM AAL5 Interworking
- Ethernet/VLAN to Frame Relay Interworking
- Ethernet/VLAN to PPP Interworking
- Ethernet to VLAN Interworking
- Frame Relay to ATM AAL5 Interworking
- Frame Relay to PPP Interworking

Finding Feature Information in This Module

Your Cisco IOS software release may not support all of the features documented in this module. To reach links to specific feature documentation in this module and to see a list of the releases in which each feature is supported, use the [“Feature Information for L2VPN Interworking”](#) section on page 58.

Finding Support Information for Platforms and Cisco IOS Software Images

Use Cisco Feature Navigator to find information about platform support and Cisco IOS software image support. Access Cisco Feature Navigator at <http://www.cisco.com/go/fn>. You must have an account on Cisco.com. If you do not have an account or have forgotten your username or password, click **Cancel** at the login dialog box and follow the instructions that appear.

Contents

- [Prerequisites for L2VPN Interworking, page 2](#)
- [Restrictions for L2VPN Interworking, page 2](#)
- [Information About L2VPN Interworking, page 13](#)
- [How to Configure L2VPN Interworking, page 15](#)



Corporate Headquarters
Cisco Systems, Inc., 170 West Tasman Drive, San Jose, CA 95134-1706 USA

© 2006 Cisco Systems, Inc. All rights reserved.

- [Configuration Examples for L2VPN Interworking, page 20](#)
- [Additional References, page 27](#)
- [Command Reference, page 29](#)
- [Feature Information for L2VPN Interworking, page 58](#)

Prerequisites for L2VPN Interworking

Before you configure L2VPN Interworking on a router:

- You must enable Cisco Express Forwarding .
- On the Cisco 12000 series Internet router, before you configure Layer 2 Tunnel Protocol version 3 (L2TPv3) for L2VPN Interworking on an IP Services Engine (ISE/Engine 3) or Engine 5 interface, you must also enable the L2VPN feature bundle on the line card. To enable the feature bundle, enter the **hw-module slot np mode feature** command in global configuration mode as follows:

```
Router# configure terminal
Router(config)# hw-module slot slot-number np mode feature
```

Restrictions for L2VPN Interworking

The following sections list the L2VPN Interworking restrictions:

- [General Restrictions, page 2](#)
- [Cisco 7200 and 7500 Series Routers Supported Port Adapters, page 3](#)
- [Cisco 7200 Series Routers Supported Interface Processors, page 4](#)
- [Cisco 7500 Series Routers Supported Interface Processors, page 4](#)
- [Cisco 10720 Internet Router Supported Line Cards, page 4](#)
- [Cisco 12000 Series Router Restrictions, page 5](#)
- [Cisco 12000 Series Routers Supported Line Cards, page 7](#)
- [Cisco 7600 Series Router Supported Line Cards, page 8](#)
- [Cisco 7600 Series Router Supported Line Cards, page 8](#)
- [Cisco 7600 Series Routers Restrictions, page 9](#)
- [Unsupported Hardware, page 10](#)
- [ATM AAL5 Interworking Restrictions, page 10](#)
- [Ethernet/VLAN Interworking Restrictions, page 10](#)
- [Frame Relay Interworking Restrictions, page 12](#)
- [PPP Interworking Restrictions, page 12](#)

General Restrictions

This section lists general restrictions that apply to L2VPN Interworking. Other restrictions that are platform- or device-specific are listed in the following sections.

- The interworking type on one provider edge (PE) router must match the interworking type on the peer PE router.
- Distributed Cisco Express Forwarding switching is supported on the Cisco 7500.
- Although Layer 2 quality of service (QoS) is supported extensively on Cisco 12000 series routers (details are given in *Any Transport over MPLS (AToM): Layer 2 QoS (Quality of Service) for the Cisco 12000 Series Router*), on other platforms only the following QoS features are supported with L2VPN Interworking:
 - Static IP type of service (ToS) or Multiprotocol Label Switching (MPLS) experimental bit (EXP) setting in tunnel header
 - IP ToS reflection in tunnel header (Layer 2 Tunnel Protocol Version 3 (L2TPv3) only)
 - Frame Relay policing
 - Frame Relay data-link connection identifier (DLCI)-based congestion management (Cisco 7500/Versatile Interface Processor (VIP))
 - One-to-one mapping of VLAN priority bits to MPLS EXP bits

Cisco 7200 and 7500 Series Routers Supported Port Adapters

L2VPN Interworking is supported only on the following port adapters in the Cisco 7200 and 7500 series routers:

- PA-FE-TX (single-port Fast Ethernet 100BASE-TX)
- PA-FE-FX (single-port Fast Ethernet 100BASE-FX)
- PA-2FE-TX (dual-port Fast Ethernet 100BASE-TX)
- PA-2FE-FX (dual-port Fast Ethernet 100BASE-FX)
- PA-8E (8-port Ethernet Adapter) [7200 only, L2TPv3 only]
- PA-4E (4-port Ethernet Adapter) [7200 only, L2TPv3 only]
- PA-12E/2FE (12-port Ethernet/2-port FE Adapter) [7200 only, L2TPv3 only]
- PA-GE (Gigabit Ethernet Port Adapter) [7200 only]
- PA-4T (4-port synchronous serial port adapter)
- PA-4T+ (enhanced 4-port synchronous serial port adapter)
- PA-8T (8-port synchronous serial port adapter)
- PA-H—single-port High-Speed Serial Interface (HSSI) adapter
- PA-2H (dual-port HSSI adapter)
- PA-MC-8E1 (8-port multichannel E1 G.703/G.704 120-ohm interfaces)
- PA-MC-2E1 (2-port multichannel E1 G.703/G.704 120-ohm interfaces)
- PA-MC-8T1—8-port multichannel T1 with integrated channel service unit (CSU) and data service unit (DSUs)
- PA-MC-4T1 (4-port multichannel T1 with integrated CSUs and DSUs)
- PA-MC-2T1 (2-port multichannel T1 with integrated CSUs and DSUs)
- PA-MC-8TE1+ (8-port multichannel T1/E1)
- PA-MC-T3 (1-port multichannel T3 interface)

- PA-MC-E3 (1-port multichannel E3 interface)
- PA-MC-2T3+ (2-port enhanced multichannel T3 port adapter)
- PA-MC-STM1 (1-port multichannel STM-1 port adapter)
- PA-T3 (single-port T3 port adapter)
- PA-E3 (single-port E3 port adapter)
- PA-2E3 (2-port T3 port adapter)
- PA-2T3 (2-port T3 port adapter)
- PA-POS-OC3SML- (single-port Packet over SONET (POS), Single-mode, long reach)
- PA-POS-OC3SMI- (single-port POS, Single-mode, intermediate reach)
- PA-POS-OC3MM- (single-port POS, Multimode)
- PA-A3-OC3 (1-port ATM OC-3/STM-1 port adapter, enhanced)
- PA-A3-OC12 (1-port ATM OC-12/STM-4 port adapter, enhanced)
- PA-A3-T3 (DS3 high-speed interface)
- PA-A3-E3 (E3 medium-speed interface)
- PA-A3-8T1IMA (ATM inverse multiplexer over ATM port adapter with 8 T1 ports)
- PA-A3-8E1IMA (ATM inverse multiplexer over ATM port adapter with 8 E1 ports)
- PA-A6 (Cisco ATM Port Adapter)

Cisco 7200 Series Routers Supported Interface Processors

L2VPN Interworking is supported only on the following Cisco 7200 series router interface processors:

- C7200-I/O-2FE
- C7200-I/O-GE+E (Only the Gigabit Ethernet port of this port adapter is supported.)
- C7200-I/O-FE
- PA-GE

Cisco 7500 Series Routers Supported Interface Processors

L2VPN Interworking is supported only on the following Cisco 7500 series router interface processors:

- GEIP (Gigabit Ethernet interface processor)
- GEIP+ (enhanced Gigabit Ethernet interface processor)

Cisco 10720 Internet Router Supported Line Cards

L2VPN Interworking is supported only on the following Cisco 10720 Internet router line cards:

- 10720-FE-TX
- 10720-FE-FX-SM
- 10720-FE-FX-MM

- 10720-GE-FE-TX
- 10720-GE-SFP-SX
- 10720-GE-SFP-LH

Cisco 12000 Series Router Restrictions

Frame Relay to PPP and High-Level Data Link Control (HDLC). Interworking

The Cisco 12000 series Internet router does not support L2VPN Interworking with PPP and HDLC transport types in Cisco IOS releases earlier than 12.0(32)S.

Starting in Cisco IOS Release 12.0(32)S, the Cisco 12000 series Internet router supports L2VPN interworking for Frame Relay over MPLS and PPP and HDLC over MPLS only on the following shared port adapters (SPAs):

- ISE/Engine 3 SPAs:
 - SPA-2XCT3/DS0 (2-port channelized T3 to DS0)
 - SPA-4XCT3/DS0 (4-port channelized T3 to DS0)
- Engine 5 SPAs:
 - SPA-1XCHSTM1/OC-3 (1-port channelized STM-1c/OC-3c to DS0)
 - SPA-8XCHT1/E1 (8-port channelized T1/E1)
 - SPA-2XOC-48-POS/RPR (2-port OC-48/STM16 POS/RPR)
 - SPA-OC-192POS-LR (1-port OC-192/STM64 POS/RPR)
 - SPA-OC-192POS-XFP (1-port OC-192/STM64 POS/RPR)

L2VPN Interworking over L2TPv3

On the Cisco 12000 series Internet router, Ethernet (bridged) interworking is not supported for L2TPv3. Only IP (routed) interworking is supported.

IP (routed) interworking is not supported in an L2TPv3 pseudowire that is configured for data sequencing (using the **sequencing** command).

Starting in Cisco IOS Release 12.0(32)SY, the Cisco 12000 series Internet router supports L2VPN Interworking over L2TPv3 tunnels in IP mode on ISE and Engine 5 line cards as follows:

- On an ISE interface configured for L2TPv3 tunneling, the following Layer 2 encapsulations are supported:
 - ATM Adaptation Layer Type-5 (AAL5)
 - Ethernet
 - 802.1q (VLAN)
 - Frame Relay DLCI
- On an Engine 5 interface configured for L2TPv3 tunneling, the following Layer 2 encapsulations are supported:
 - Ethernet
 - 802.1q (VLAN)
 - Frame Relay DLCI

For more information, refer to [Layer 2 Tunnel Protocol Version 3](#).

The only frame format supported for L2TPv3 interworking on Engine 5 Ethernet SPAs is Ethernet Version 2 (also known as Ethernet II) with the Ether type 0x0800 value set as Internet Protocol Payload and (optionally) 802.1q VLAN. Ethernet packets with other Ethernet frame formats are dropped.

Remote Ethernet Port Shutdown Support

The Cisco Remote Ethernet Port Shutdown feature (which minimizes potential data loss after a remote link failure) is supported only on the following Engine 5 Ethernet SPAs:

- SPA-8XFE (8-port Fast Ethernet)
- SPA-2X1GE (2-port Gigabit Ethernet)
- SPA-5X1GE (5-port Gigabit Ethernet)
- SPA-10X1GE (10-port Gigabit Ethernet)
- SPA-1X10GE (1-port 10-Gigabit Ethernet)

For more information about this feature, refer to [Any Transport over MPLS \(AToM\): Remote Ethernet Port Shutdown](#).

L2VPN Any-to-Any Interworking on Engine 5 Line Cards

Table 1 shows the different combinations of transport types supported for L2VPN interworking on Engine 3 and Engine 5 SPA interfaces connected through an attachment circuit over MPLS or L2TPv3.

Table 1 Engine 3 and Engine 5 Line Cards/SPAs Supported for L2VPN Interworking

Attachment Circuit 1 (AC1)	Attachment Circuit 2 (AC2)	Interworking Mode	AC1 Engine Type and Line Card/SPA	AC2 Engine Type and Line Card/SPA
Frame Relay	Frame Relay	IP	Engine 5 POS and channelized	Engine 3 ATM line cards
Frame Relay	ATM	Ethernet	Engine 5 POS and channelized	Engine 3 ATM line cards
Frame Relay	ATM	IP	Engine 5 POS and channelized	Engine 3 ATM line cards
Frame Relay	Ethernet	Ethernet	Engine 5 POS and channelized	Engine 5 Gigabit Ethernet
Frame Relay	Ethernet	IP	Engine 5 POS and channelized	Engine 5 Gigabit Ethernet
Frame Relay	VLAN	Ethernet	Engine 5 POS and channelized	Engine 5 Gigabit Ethernet
Frame Relay	VLAN	IP	Engine 5 POS and channelized	Engine 5 Gigabit Ethernet
Ethernet	Ethernet	Ethernet	Engine 5 Gigabit Ethernet	Engine 5 Gigabit Ethernet
Ethernet	Ethernet	IP	Engine 5 Gigabit Ethernet	Engine 5 Gigabit Ethernet
Ethernet	VLAN	Ethernet	Engine 5 Gigabit Ethernet	Engine 5 Gigabit Ethernet
Ethernet	VLAN	IP	Engine 5 Gigabit Ethernet	Engine 5 Gigabit Ethernet

Table 1 Engine 3 and Engine 5 Line Cards/SPAs Supported for L2VPN Interworking

Attachment Circuit 1 (AC1)	Attachment Circuit 2 (AC2)	Interworking Mode	AC1 Engine Type and Line Card/SPA	AC2 Engine Type and Line Card/SPA
ATM	Ethernet	Ethernet	Engine 3 ATM line cards	Engine 5 Gigabit Ethernet
ATM	Ethernet	IP	Engine 3 ATM line cards	Engine 5 Gigabit Ethernet

Cisco 12000 Series Routers Supported Line Cards

L2VPN Interworking is supported only on the following Cisco 12000 series router line cards:

- 4GE-SFP-LC
- 4OC-12X/ATM-MM-SC
- 4OC-12X/ATM-IR-SC
- 4OC-3X/ATM-IR-SC
- 4OC-3X/POS-MM-MJ-B
- 4OC-3X/POS-IR-LC-B
- 4OC-3X/POS-LR-LC-B
- 8OC-3X/POS-MM-MJ-B
- 8OC-3X/POS-IR-LC-B
- 16OC-3X/POS-M-MJ-B
- 16OC-3X/POS-I-LC-B
- 4OC-12X/POS-M-SC-B
- 4OC-12X/POS-I-SC-B
- OC-48X/POS-SR-SC
- OC-48X/POS-LR-SC
- ISE Engine 3 SPAs:
 - SPA-2XCT3/DS0 (2-port channelized T3 to DS0)
 - SPA-4XCT3/DS0 (4-port channelized T3 to DS0)
 - SPA-2XT3/E3 (2-port T3/E3 Serial)
 - SPA-4XT3/E3 (4-port T3/E3 Serial)
- Engine 5 SPAs:
 - SPA-1XCHSTM1/OC-3 (1-port channelized STM-1c/OC-3c to DS0)
 - SPA-8XCHT1/E1 (8-port channelized T1/E1)
 - SPA-1XTENGE-XFP (1-port 10-Gigabit Ethernet)
 - SPA-1X10GE-L-V2 (1-port 10-Gigabit Ethernet)
 - SPA-2X1GE (2-port Gigabit Ethernet)
 - SPA-2X1GE-V2 (2-port Gigabit Ethernet)

- SPA-5X1GE (5-port Gigabit Ethernet)
- SPA-5X1GE-V2 (5-port Gigabit Ethernet)
- SPA-10X1GE (10-port Gigabit Ethernet)
- SPA-10X1GE-V2 (10-port Gigabit Ethernet)
- SPA-8XFE (8-port Fast Ethernet)
- SPA-8X1FE-TX-V2 (8-port 10/100 Ethernet)
- SPA-4XOC-3-POS-V2 (4-port OC-3/STM-4 POS)
- SPA-8XOC-3-POS (8-port OC-3/STM-4 POS)
- SPA-2XOC-12-POS (2-port OC-12/STM-4 POS)
- 4SPA-4XOC-12-POS (4-port OC-12/STM-4 POS)
- SPA-8XOC-12-POS (8-port OC-12/STM-4 POS)
- SPA-2XOC-48-POS/RPR (2-port OC-48/STM-16 POS/RPR)
- SPA-OC-192POS-VSR (1-port OC-192/STM-64 POS/RPR)
- SPA-OC-192POS-LR (1-port OC-192/STM-64 POS/RPR)
- SPA-OC-192POS-XFP (1-port OC-192/STM-64 POS/RPR)
- SPA Interface Processors (SIPs):
 - 12000-SIP-400 (2.5G ISE SPA Interface Processor)
 - 12000-SIP-600 (10G Engine 5 SPA Interface Processor)
 - 12000-SIP-401 (2.5G multiservice engine SPA Interface Processor)
 - 12000-SIP-501 (5G multiservice engine SPA Interface Processor)
 - 12000-SIP-601 (10G multiservice engine SPA Interface Processor)

Cisco 7600 Series Router Supported Line Cards

The following line cards are supported on the Cisco 7600 series router. [Table 2](#) shows the line cards that are supported on the WAN (ATM, Frame Relay, or PPP) side of the interworking link. [Table 3](#) shows the line cards that are supported on the Ethernet side of the interworking link.

Table 2 Cisco 7600 Series Routers: Supported Line Cards for the WAN Side

Interworking Type	Core-Facing Line Cards	Customer-Edge Line Cards
Ethernet (Bridged)	Any	EflexWAN
(ATM and Frame Relay)		SIP-200
IP (Routed)	Any	EflexWAN
(ATM, Frame Relay, and PPP)		SIP-200

Table 3 Cisco 7600 Series Routers: Supported Line Cards for the Ethernet Side

Interworking Type	EoMPLS Mode	Core-Facing Line Cards	Customer-Edge Line Cards
Ethernet (Bridged)	PFC-based	Any, except optical service module (OSM)	Catalyst LAN SIP-600
Ethernet (Bridged)	WAN-based	EflexWAN SIP-200 SIP-400 SIP-600	Catalyst LAN EflexWAN (with MPB) SIP-200 (with MPB) SIP-400 (with MPB) SIP-600
Ethernet (Bridged)	Scalable (with E-MPB)	Any, except OSM	SIP-600 with gigabit Ethernet (GE) SPA
IP (Routed)	PFC-based	Catalyst LAN SIP-600	Catalyst LAN SIP-600
IP (Routed)	WAN-based	EflexWAN SIP-200	Catalyst LAN EflexWAN (with MPB) SIP-200 (with MPB) SIP-400 (with MPB) SIP-600

Cisco 7600 Series Routers Restrictions

- The Cisco 7600 series routers do not support L2VPN Interworking over L2TPv3.
- Cisco 7600 series routers support only the following interworking types:
 - Ethernet/VLAN to Frame Relay (IP and Ethernet modes)
 - Ethernet/VLAN to ATM AAL5SNAP (IP and Ethernet modes)
 - Ethernet/VLAN to PPP (IP only)
 - Ethernet to VLAN Interworking
- Cisco 7600 series routers do not support the following interworking types:
 - Ethernet/VLAN to ATM AAL5MUX
 - Frame Relay to PPP Interworking
 - Frame Relay to ATM AAL5 Interworking
- Both ends of the interworking link must be configured with the same encapsulation and interworking type:
 - If you use Ethernet encapsulation, you must use the Ethernet (bridged) interworking type. If you are not using Ethernet encapsulation, you can use a bridging mechanism, such as routed bridge encapsulation (RBE).
 - If you use an IP encapsulation (such as ATM or Frame Relay), you must use the IP (routed) interworking type. The PE routers negotiate the process for learning and resolving addresses.

Unsupported Hardware

The following hardware is not supported:

- Cisco 7200—non-VXR chassis
- Cisco 7500—RSP1 and RSP2
- Cisco 7500—Cisco Versatile Interface Processor 2, Model 40 (VIP2-40) and earlier
- Cisco 10720—OC-48c/STM-16c Spatial Reuse Protocol (SRP)/PoS uplink modules

ATM AAL5 Interworking Restrictions

The following restrictions apply to ATM AAL5 Interworking:

- Cisco 12000 series Engine 5 line cards do not support L2VPN interworking on ATM. On other line cards and platforms, only ATM AAL5 VC mode is supported; ATM VP and port mode are not supported.
- Switched virtual circuits (SVCs) are not supported.
- Inverse ARP is not supported with IP interworking.
- Customer edge (CE) routers must use point-to-point subinterfaces or static maps.
- Both AAL5MUX and AAL5SNAP encapsulation are supported. In the case of AAL5MUX, no translation is needed.
- On the Cisco 12000 series Engine 3 line card, Network Layer Protocol ID (NLPID) encapsulation is not supported in routed mode; and neither NLPID nor AAL5MUX is supported in bridged mode.
- In the Ethernet end-to-end over ATM scenario, the following translations are supported:
 - Ethernet without LAN frame check sequence (FCS) (AAAA030080C200070000)
 - Spanning tree (AAAA030080c2000E)

Everything else is dropped.

- In the IP over ATM scenario, the IPv4 (AAAA030000000800) translation is supported. Everything else is dropped.
- Operation, Administration, and Management (OAM) emulation for L2VPN Interworking is the same as like-to-like. The end-to-end F5 loopback cells are looped back on the PE router. When the pseudowire is down, an F5 end-to-end segment Alarm Indication Signal (AIS)/Remote Defect Identification (RDI) is sent from the PE router to the CE router.
- Interim Local Management Interface (ILMI) can manage virtual circuits (VCs) and permanent virtual circuits (PVCs). To enable ILMI management, configure ILMI PVC 0/16 on the PE router's ATM interface. If a PVC is provisioned or deleted, an ilmiVCCChange trap is sent to the CE router. Only the user side of the User-Network Interface (UNI) is supported; the network side of the UNI is not supported.

Ethernet/VLAN Interworking Restrictions

The following restrictions apply to Ethernet/VLAN interworking:

- On the Cisco 12000 series Internet router, Ethernet (bridged) interworking is not supported for L2TPv3.

In an L2VPN Interworking configuration, after you configure L2TPv3 tunnel encapsulation for a pseudowire using the **encapsulation l2tpv3** command, you cannot enter the **interworking ethernet** command.

- On Ethernet SPAs on the Cisco 12000 series Internet router, the only frame format supported for L2TPv3 interworking is Ethernet Version 2 (also known as Ethernet II) with the Ether type 0x0800 value set as Internet Protocol Payload and [optionally] 802.1q VLAN.

Ethernet packets with other Ethernet frame formats are dropped.

- The Cisco 10720 Internet router supports Ethernet to VLAN Interworking Ethernet only over L2TPv3.
- Ethernet interworking for a raw Ethernet port or a VLAN trunk is not supported. Traffic streams are not kept separate when traffic is sent between transport types.
- In routed mode, only one CE router can be attached to an Ethernet PE router.
- There must be a one-to-one relationship between an attachment circuit and the pseudowire. Point-to-multipoint or multipoint-to-point configurations are not supported.
- Configure routing protocols for point-to-point operation on the CE routers when configuring an Ethernet to non-Ethernet setup.
- In the IP interworking mode, the IPv4 (0800) translation is supported. The PE router captures ARP (0806) packets and responds with its own MAC address (proxy ARP). Everything else is dropped.
- The Ethernet or VLAN must contain only two IP devices: PE router and CE router. The PE router performs proxy ARP and responds to all ARP requests it receives. Therefore, only one CE and one PE router should be on the Ethernet or VLAN segment.
- If the CE routers are doing static routing, you can perform the following tasks:
 - The PE router needs to learn the MAC address of the CE router to correctly forward traffic to it. The Ethernet PE router sends an Internet Control Message Protocol (ICMP) Router discovery protocol (RDP) solicitation message with the source IP address as zero. The Ethernet CE router responds to this solicitation message. To configure the Cisco CE router's Ethernet or VLAN interface to respond to the ICMP RDP solicitation message, issue the **ip irdp** command in interface configuration mode. If you do not configure the CE router, traffic is dropped until the CE router sends traffic toward the PE router.
 - To disable the CE routers from running the router discovery protocol, issue the **ip irdp maxadvertinterval 0** command in interface mode.
- When the PE router on the Ethernet side receives a VLAN tagged packet from the CE router, the PE router removes the VLAN tag from the Ethernet frame from the CE router. In the reverse direction, the PE router adds the VLAN tag to the frames before sending the frame to the CE router. The VLAN tag needs to be inserted or removed in this way when you configure VLAN to Ethernet interworking, VLAN to Frame Relay, or ATM using Ethernet (bridged) interworking.

This restriction applies if you configure interworking between Ethernet and VLAN with Catalyst switches as the CE routers. The spanning tree protocol is supported for Ethernet interworking. Ethernet interworking between an Ethernet port and a VLAN supports spanning tree protocol only on VLAN 1. Configure VLAN 1 as a nonnative VLAN.

- In bridged interworking from VLAN to Frame Relay, the Frame Relay PE router does not strip off VLAN tags from the Ethernet traffic it receives.
- When you change the interworking configuration on an Ethernet PE router, clear the ARP entry on the adjacent CE router so that it can learn the new MAC address. Otherwise, you might experience traffic drops.

Frame Relay Interworking Restrictions

The following restrictions apply to Frame Relay interworking:

- The attachment circuit maximum transmission unit (MTU) sizes must match when you connect them over MPLS. By default, the MTU size associated with a Frame Relay DLCI is the interface MTU. This may cause problems, for example, when connecting some DLCIs on a PoS interface (with a default MTU of 4470 bytes) to Ethernet or VLAN (with a default MTU of 1500 bytes) and other DLCIs on the same PoS interface to ATM (with a default MTU of 4470 bytes). To avoid reducing all the interface MTUs to the lowest common denominator (1500 bytes in this case), you can specify the MTU for individual DLCIs using the **mtu** command.
- Only DLCI mode is supported. Port mode is not supported.
- Configure Frame Relay switching to use DCE or Network-to-Network Interface (NNI). DTE mode does not report status in the Local Management Interface (LMI) process. If a Frame Relay over MPLS circuit goes down and the PE router is in DTE mode, the CE router is never informed of the disabled circuit. You must configure the **frame-relay switching** command in global configuration mode in order to configure DCE or NNI.
- Frame Relay policing is nondistributed on the Cisco 7500 series routers. If you enable Frame Relay policing, traffic is sent to the RSP for processing.
- Inverse ARP is not supported with IP interworking. CE routers must use point-to-point subinterfaces or static maps.
- The PE router automatically supports translation of both the Cisco encapsulations and the Internet Engineering Task Force (IETF) encapsulations that come from the CE, but translates only to IETF when sending to the CE router. This is not a problem for the Cisco CE router, because it can handle IETF encapsulation on receipt even if it is configured to send Cisco encapsulation.
- With Ethernet interworking, the following translations are supported:
 - Ethernet without LAN FCS (0300800080C20007 or 6558)
 - Spanning tree (0300800080C2000E or 4242)All other translations are dropped.
- With IP interworking, the IPv4 (03CC or 0800) translation is supported. All other translations are dropped.
- PVC status signaling works the same way as in like-to-like case. The PE router reports the PVC status to the CE router, based on the availability of the pseudowire. PVC status detected by the PE router will also be reflected into the pseudowire. LMI to OAM interworking is supported when you connect Frame Relay to ATM.

PPP Interworking Restrictions

The following restrictions apply to PPP interworking:

- There must be a one-to-one relationship between a PPP session and the pseudowire. Multiple PPP sessions multiplexing over the pseudowire is not supported.
- There must be a one-to-one relationship between a PPP session and a Frame Relay DLCI. Each Frame Relay PVC must have only one PPP session.
- Only IP (IPv4 (0021) interworking is supported. Link Control Protocol (LCP) packets and Internet Protocol Control Protocol (IPCP) packets are terminated at the PE router. Everything else is dropped.

- Proxy IPCP is automatically enabled on the PE router when IP interworking is configured on the pseudowire.
- By default, the PE router assumes that the CE router knows the remote CE router's IP address.
- Password Authentication Protocol (PAP) and Challenge-Handshake Authentication Protocol (CHAP) authentication are supported.

Information About L2VPN Interworking

The following sections provide an introduction to L2VPN interworking.

- [Overview of L2VPN Interworking, page 13](#)
- [L2VPN Interworking Modes, page 13](#)

Overview of L2VPN Interworking

Layer 2 transport over MPLS and IP already exists for like-to-like attachment circuits, such as Ethernet-to-Ethernet or PPP-to-PPP. L2VPN Interworking builds on this functionality by allowing disparate attachment circuits to be connected. An interworking function facilitates the translation between the different Layer 2 encapsulations. [Figure 1](#) is an example of Layer 2 interworking, where ATM and Frame Relay packets travel over the MPLS cloud.

Figure 1 ATM to Frame Relay Interworking Example

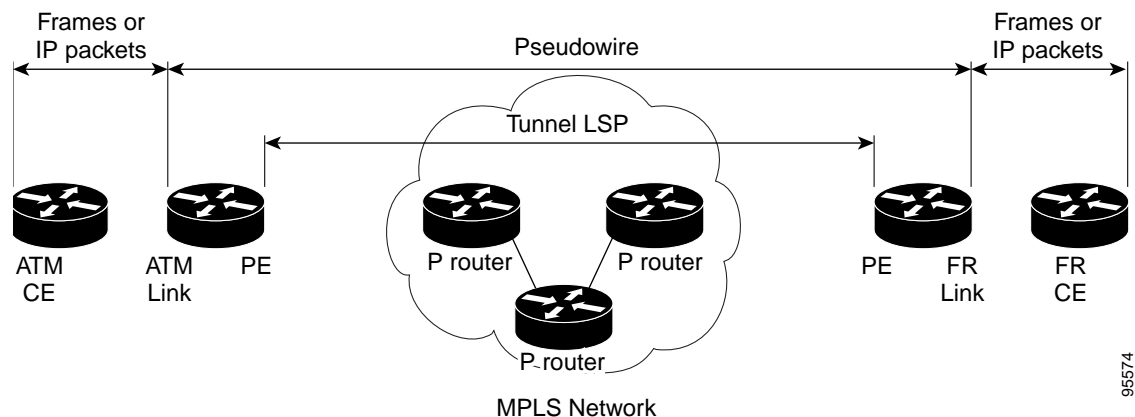

The L2VPN Interworking feature supports Ethernet, 802.1Q (VLAN), Frame Relay, ATM AAL5, and PPP attachment circuits over MPLS and L2TPv3. The features and restrictions for like-to-like functionality also apply to L2VPN Interworking.

L2VPN Interworking Modes

L2VPN Interworking works in either Ethernet (“bridged”) mode or IP (“routed”) mode. You specify the mode by issuing the **interworking {ethernet | ip}** command in pseudowire-class configuration mode.

The **interworking** command causes the attachment circuits to be terminated locally. The two keywords perform the following functions:

95574

- The **ethernet** keyword causes Ethernet frames to be extracted from the attachment circuit and sent over the pseudowire. Ethernet end-to-end transmission is assumed. Attachment circuit frames that are not Ethernet are dropped. In the case of VLAN, the VLAN tag is removed, leaving an untagged Ethernet frame.
- The **ip** keyword causes IP packets to be extracted from the attachment circuit and sent over the pseudowire. Attachment circuit frames that do not contain IPv4 packets are dropped.

The supported L2VPN Interworking features are listed in [Table 4](#).

Table 4 L2VPN Interworking Supported Features

Feature	MPLS or L2TPv3 Support	IP or Ethernet Support
Ethernet/VLAN to ATM AAL5	MPLS L2TPv3 (12000 series only)	IP Ethernet
Ethernet/VLAN to Frame Relay	MPLS L2TPv3	IP Ethernet
Ethernet/VLAN to PPP	MPLS	IP
Ethernet to VLAN	MPLS L2TPv3	IP Ethernet
Frame Relay to ATM AAL5	MPLS L2TPv3 (12000 series only)	IP
Frame Relay to Ethernet or VLAN	MPLS L2TPv3	IP Ethernet
Frame Relay to PPP	MPLS L2TPv3	IP

Note: On the Cisco 12000 series Internet router:

- Ethernet (bridged) interworking is not supported for L2TPv3.
- IP (routed) interworking is not supported in an L2TPv3 pseudowire configured for data sequencing (using the **sequencing** command).



Note

The Cisco 7600 series routers do not support L2VPN Interworking over L2TPv3.

The following sections explain more about Ethernet and IP interworking modes.

Ethernet Interworking

As mentioned earlier, Ethernet Interworking is also called bridged interworking. Ethernet frames are bridged across the pseudowire. The CE routers could be natively bridging Ethernet or could be routing using a bridged encapsulation model, such as Bridge Virtual Interface (BVI) or RBE. The PE routers operate in Ethernet like-to-like mode.

This mode is used to offer the following services:

- LAN services—An example is an enterprise that has several sites, where some sites have Ethernet connectivity to the service provider (SP) network and others have ATM connectivity. The enterprise wants LAN connectivity to all its sites. In this case, traffic from the Ethernet or VLAN of one site can be sent through the IP/MPLS network and encapsulated as bridged traffic over an ATM VCof another site.
- Connectivity services—An example is an enterprise that has different sites that are running an Internal Gateway Protocol (IGP) routing protocol, which has incompatible procedures on broadcast and nonbroadcast links. The enterprise has several sites that are running an IGP, such as Open Shortest Path First (OSPF) or Intermediate System to Intermediate System (IS-IS), between the sites. In this scenario, some of the procedures (such as route advertisement or designated router) depend on the underlying Layer 2 protocol and are different for a point-to-point ATM connection versus a broadcast Ethernet connection. Therefore, the bridged encapsulation over ATM can be used to achieve homogenous Ethernet connectivity between the CE routers running the IGP.

IP Interworking

IP Interworking is also called routed interworking. The CE routers encapsulate IP on the link between the CE and PE routers. A new VC type is used to signal the IP pseudowire in MPLS and L2TPv3. Translation between the Layer 2 and IP encapsulations across the pseudowire is required. Special consideration needs to be given to address resolution and routing protocol operation, because these are handled differently on different Layer 2 encapsulations.

This mode is used to provide IP connectivity between sites, regardless of the Layer 2 connectivity to these sites. It is different from a layer 3 VPN because it is point-to-point in nature and the service provider does not maintain any customer routing information.

Address resolution is encapsulation dependent:

- Ethernet uses ARP
- Frame Relay and ATM use Inverse ARP
- PPP uses IPCP

Therefore, address resolution must be terminated on the PE router. End-to-end address resolution is not supported.

Routing protocols operate differently over broadcast and point-to-point media. For Ethernet, the CE routers must either use static routing or configure the routing protocols to treat the Ethernet side as a point-to-point network.

How to Configure L2VPN Interworking

The following sections explain the tasks you can perform to configure L2VPN Interworking:

- [Configuring L2VPN Interworking, page 16](#) (required)
- [Configuring Static IP Addresses for L2VPN Interworking for PPP, page 17](#) (optional)
- [Verifying the L2VPN Interworking Configuration, page 17](#) (optional)

Configuring L2VPN Interworking

Configuring the L2VPN Interworking feature requires that you add the **interworking** command to the list of commands that comprise the pseudowire. The steps for configuring the pseudowire for L2VPN Interworking are included in this section. You use the **interworking** command as part of the overall AToM or L2TPv3 configuration. For specific instructions on configuring Any Transport over MPLS (AToM) or L2TPv3, see the following documents:

- *Layer 2 Tunnel Protocol Version 3*
- *Any Transport over MPLS*

SUMMARY STEPS

1. **enable**
2. **configure terminal**
3. **hw-module slot *slot-number* np mode feature**
4. **pseudowire-class *name***
5. **encapsulation {mpls | l2tpv3}**
6. **interworking {ethernet | ip}**

DETAILED STEPS

	Command or Action	Purpose
Step 1	enable Example: Router> enable	Enables privileged EXEC mode. • Enter your password if prompted.
Step 2	configure terminal Example: Router# configure terminal	Enters global configuration mode.
Step 3	hw-module slot <i>slot-number</i> np mode feature Example: Router(config)# hw-module slot 3 np mode feature	(Optional) Enter this command only on a Cisco 12000 series Internet router if you use L2TPv3 for L2VPN Interworking on an ISE (Engine 3) or Engine 5 interface. In this case, you must first enable the L2VPN feature bundle on the line card by entering the hw-module slot <i>slot-number</i> np mode feature command.
Step 4	pseudowire-class <i>name</i> Example: Router(config)# pseudowire-class class1	Establishes a pseudowire class with a name that you specify and enters pseudowire class configuration mode.

	Command or Action	Purpose
Step 5	<pre>encapsulation {mpls l2tpv3}</pre> <p>Example: Router(config-pw)# encapsulation mpls</p>	Specifies the tunneling encapsulation, which is either mpls or l2tpv3 .
Step 6	<pre>interworking {ethernet ip}</pre> <p>Example: Router(config-pw)# interworking ip</p>	<p>Specifies the type of pseudowire and the type of traffic that can flow across it.</p> <p>Note On the Cisco 12000 series Internet router, Ethernet (bridged) interworking is not supported for L2TPv3. After you configure the L2TPv3 tunnel encapsulation for the pseudowire using the encapsulation l2tpv3 command, you cannot enter the interworking ethernet command.</p>

Configuring Static IP Addresses for L2VPN Interworking for PPP

If the PE router needs to perform address resolution with the local CE router for PPP, you can configure the remote CE router's IP address on the PE router. Issue the **ppp ipcp address proxy** command with the remote CE router's IP address on the PE router's xconnect PPP interface. The following example shows a sample configuration:

```
pseudowire-class ip-interworking
  encapsulation mpls
  interworking ip

interface Serial12/0
  encapsulation ppp
  xconnect 10.0.0.2 200 pw-class ip-interworking
  ppp ipcp address proxy 10.65.32.14
```

You can also configure the remote CE router's IP address on the local CE router with the **peer default ip address** command if the local CE router performs address resolution.

Verifying the L2VPN Interworking Configuration

To verify the L2VPN Interworking configuration, you can use the following commands.

SUMMARY STEPS

1. **show l2tun session all** (L2TPv3 only)
2. **show arp**
3. **ping**
4. **show l2tun session interworking** (L2TPv3 only)
5. **show mpls l2transport vc detail** (AToM only)

DETAILED STEPS

Step 1 show l2tun session all (L2TPv3 only)

For L2TPv3, you can verify the L2VPN Interworking configuration using the **show l2tun session all** command on the PE routers. In the following example, the interworking type is shown in bold.

PE1	PE2
<pre> Router# show l2tun session all Session Information Total tunnels 1 sessions 1 Session id 15736 is up, tunnel id 35411 Call serial number is 4035100045 Remote tunnel name is PE2 Internet address is 10.9.9.9 Session is L2TP signalled Session state is established, time since change 1d22h 16 Packets sent, 16 received 1518 Bytes sent, 1230 received Receive packets dropped: out-of-order: 0 total: 0 Send packets dropped: exceeded session MTU: 0 total: 0 Session vcid is 123 Session Layer 2 circuit, type is Ethernet, name is FastEthernet1/1/0 Circuit state is UP Remote session id is 26570, remote tunnel id 46882 DF bit off, ToS reflect disabled, ToS value 0, TTL value 255 No session cookie information available FS cached header information: encaps size = 24 bytes 00000000 00000000 00000000 00000000 00000000 00000000 Sequencing is off </pre>	<pre> Router# show l2tun session all Session Information Total tunnels 1 sessions 1 Session id 26570 is up, tunnel id 46882 Call serial number is 4035100045 Remote tunnel name is PE1 Internet address is 10.8.8.8 Session is L2TP signalled Session state is established, time since change 1d22h 16 Packets sent, 16 received 1230 Bytes sent, 1230 received Receive packets dropped: out-of-order: 0 total: 0 Send packets dropped: exceeded session MTU: 0 total: 0 Session vcid is 123 Session Layer 2 circuit, type is Ethernet Vlan, name is FastEthernet2/0.1:10 Circuit state is UP, interworking type is Ethernet Remote session id is 15736, remote tunnel id 35411 DF bit off, ToS reflect disabled, ToS value 0, TTL value 255 No session cookie information available FS cached header information: encaps size = 24 bytes 00000000 00000000 00000000 00000000 00000000 00000000 Sequencing is off </pre>

Step 2 show arp

You can issue **show arp** command between the CE routers to ensure that data is being sent:

```
Router# show arp
```

Protocol	Address	Age (min)	Hardware Addr	Type	Interface
Internet	10.1.1.5	134	0005.0032.0854	ARPA	FastEthernet0/0
Internet	10.1.1.7	-	0005.0032.0000	ARPA	FastEthernet0/0

Step 3 ping

You can issue ping command between the CE routers to ensure that data is being sent:

```
Router# ping 10.1.1.5
```

```

Type escape sequence to abort.
Sending 5, 100-byte ICMP Echos to 10.1.1.5, timeout is 2 seconds:
!!!!
Success rate is 100 percent (5/5), round-trip min/avg/max = 1/2/4 ms

```

Step 4 show l2tun session interworking

To verify that the interworking type is correctly set, use the **show l2tun session interworking** command. Enter the command on the PE routers that are performing the interworking translation.

- In Example 1, the PE router performs the raw Ethernet translation. The command output displays the interworking type with a dash (-).
- In Example 2, the PE router performs the Ethernet VLAN translation. The command output displays the interworking type as ETH.

Example 1 Command Output for Raw Ethernet Translation

```
Router# show l2tun session interworking

Session Information Total tunnels 1 sessions 1

LocID      TunID      Peer-address  Type IWrk Username, Intf/Vcid, Circuit
15736      35411      10.9.9.9      ETH  -   123,      Fa1/1/0
```

Example 2 Command Output for Ethernet VLAN Translation

```
Router# show l2tun session interworking

Session Information Total tunnels 1 sessions 1

LocID      TunID      Peer-address  Type IWrk Username, Intf/Vcid, Circuit
26570      46882      10.8.8.8      VLAN ETH  123,      Fa2/0.1:10
```

Step 5 show mpls l2transport vc detail

You can verify the AToM configuration by using the **show mpls l2transport vc detail** command. In the following example, the interworking type is shown in bold.

PE1	PE2
<pre>Router# show mpls l2transport vc detail Local interface: Fa1/1/0 up, line protocol up, Ethernet up Destination address: 10.9.9.9, VC ID: 123, VC status: up Preferred path: not configured Default path: active Tunnel label: 17, next hop 10.1.1.3 Output interface: Fa4/0/0, imposed label stack {17 20} Create time: 01:43:50, last status change time: 01:43:33 Signaling protocol: LDP, peer 10.9.9.9:0 up MPLS VC labels: local 16, remote 20 Group ID: local 0, remote 0 MTU: local 1500, remote 1500 Remote interface description: Sequencing: receive disabled, send disabled VC statistics: packet totals: receive 15, send 4184 byte totals: receive 1830, send 309248 packet drops: receive 0, send 0</pre>	<pre>Router# show mpls l2transport vc detail Local interface: Fa2/0.3 up, line protocol up, Eth VLAN 10 up MPLS VC type is Ethernet, interworking type is Ethernet Destination address: 10.8.8.8, VC ID: 123, VC status: up Preferred path: not configured Default path: active Tunnel label: 16, next hop 10.1.1.3 Output interface: Fa6/0, imposed label stack {16 16} Create time: 00:00:26, last status change time: 00:00:06 Signaling protocol: LDP, peer 10.8.8.8:0 up MPLS VC labels: local 20, remote 16 Group ID: local 0, remote 0 MTU: local 1500, remote 1500 Remote interface description: Sequencing: receive disabled, send disabled VC statistics: packet totals: receive 5, send 0 byte totals: receive 340, send 0 packet drops: receive 0, send 0</pre>

Configuration Examples for L2VPN Interworking

The following sections show examples of L2VPN Interworking:

- [Ethernet to VLAN over L2TPV3 \(Bridged\): Example, page 20](#)
- [Ethernet to VLAN over AToM \(Bridged\): Example, page 21](#)
- [Frame Relay to VLAN over L2TPV3 \(Routed\): Example, page 21](#)
- [Frame Relay to VLAN over AToM \(Routed\): Example, page 22](#)
- [Frame Relay to ATM AAL5 over AToM \(Routed\): Example, page 23](#)
- [VLAN to ATM AAL5 over AToM \(Bridged\): Example, page 24](#)
- [Frame Relay to PPP over L2TPv3 \(Routed\): Example, page 25](#)
- [Frame Relay to PPP over AToM \(Routed\): Example, page 26](#)
- [Ethernet/VLAN to PPP over AToM \(Routed\): Example, page 27](#)

Ethernet to VLAN over L2TPV3 (Bridged): Example

The following example shows the configuration of Ethernet to VLAN over L2TPv3:

PE1	PE2
<pre> ip cef ! l2tp-class interworking-class authentication hostname PE1 password 0 lab ! pseudowire-class inter-ether-vlan encapsulation l2tpv3 interworking ethernet protocol l2tpv3 interworking-class ip local interface Loopback0 ! interface Loopback0 ip address 10.8.8.8 255.255.255.255 ! interface FastEthernet1/0 xconnect 10.9.9.9 1 pw-class inter-ether-vlan </pre>	<pre> ip cef ! l2tp-class interworking-class authentication hostname PE2 password 0 lab ! pseudowire-class inter-ether-vlan encapsulation l2tpv3 interworking ethernet protocol l2tpv3 interworking-class ip local interface Loopback0 ! interface Loopback0 ip address 10.9.9.9 255.255.255.255 ! interface FastEthernet0/0 no ip address ! interface FastEthernet0/0.3 encapsulation dot1Q 10 xconnect 10.8.8.8 1 pw-class inter-ether-vlan </pre>

Ethernet to VLAN over AToM (Bridged): Example

The following example shows the configuration of Ethernet to VLAN over AToM:

PE1	PE2
<pre> ip cef ! mpls label protocol ldp mpls ldp router-id Loopback0 force ! pseudowire-class atom-eth-iw encapsulation mpls interworking ethernet ! interface Loopback0 ip address 10.8.8.8 255.255.255.255 ! interface FastEthernet1/0.1 encapsulation dot1q 100 xconnect 10.9.9.9 123 pw-class atom-eth-iw </pre>	<pre> ip cef ! mpls label protocol ldp mpls ldp router-id Loopback0 force ! pseudowire-class atom encapsulation mpls ! interface Loopback0 ip address 10.9.9.9 255.255.255.255 ! interface FastEthernet0/0 no ip address ! interface FastEthernet1/0 xconnect 10.9.9.9 123 pw-class atom </pre>

Frame Relay to VLAN over L2TPV3 (Routed): Example

The following example shows the configuration of Frame Relay to VLAN over L2TPv3:

PE1	PE2
<pre> configure terminal ip cef frame-relay switching ! ! interface loopback 0 ip address 10.8.8.8 255.255.255.255 no shutdown ! pseudowire-class ip encapsulation l2tpv3 interworking ip ip local interface loopback0 ! interface POS1/0 encapsulation frame-relay clock source internal logging event dlci-status-change no shutdown no fair-queue ! connect fr-vlan POS1/0 206 l2transport xconnect 10.9.9.9 6 pw-class ip ! router ospf 10 network 10.0.0.2 0.0.0.0 area 0 network 10.8.8.8 0.0.0.0 area 0 </pre>	<pre> configure terminal ip routing ip cef frame-relay switching ! interface loopback 0 ip address 10.9.9.9 255.255.255.255 no shutdown ! pseudowire-class ip encapsulation l2tpv3 interworking ip ip local interface loopback0 ! interface FastEthernet1/0/1 speed 10 no shutdown ! interface FastEthernet1/0/1.6 encapsulation dot1q 6 xconnect 10.8.8.8 6 pw-class ip no shutdown ! router ospf 10 network 10.0.0.2 0.0.0.0 area 0 network 10.9.9.9 0.0.0.0 area 0 </pre>

Frame Relay to VLAN over AToM (Routed): Example

The following example shows the configuration of Frame Relay to VLAN over AToM:

PE1	PE2
<pre> configure terminal ip cef frame-relay switching ! mpls label protocol ldp mpls ldp router-id loopback0 mpls ip ! pseudowire-class atom encapsulation mpls interworking ip ! interface loopback 0 ip address 10.8.8.8 255.255.255.255 no shutdown ! connect fr-vlan POS1/0 206 l2transport xconnect 10.9.9.9 6 pw-class atom </pre>	<pre> configure terminal ip routing ip cef frame-relay switching ! mpls label protocol ldp mpls ldp router-id loopback0 mpls ip ! pseudowire-class atom encapsulation mpls interworking ip ! interface loopback 0 ip address 10.9.9.9 255.255.255.255 no shutdown ! interface FastEthernet1/0/1.6 encapsulation dot1Q 6 xconnect 10.8.8.8 6 pw-class atom no shutdown </pre>

Frame Relay to ATM AAL5 over AToM (Routed): Example



Note Frame Relay to ATM AAL5 is available only with AToM in IP mode.

The following example shows the configuration of Frame Relay to ATM AAL5 over AToM:

PE1	PE2
<pre> ip cef frame-relay switching mpls ip mpls label protocol ldp mpls ldp router-id loopback0 force pseudowire-class fratmip encapsulation mpls interworking ip interface Loopback0 ip address 10.33.33.33 255.255.255.255 interface serial 2/0 encapsulation frame-relay ietf frame-relay intf-type dce connect fr-eth serial 2/0 100 l2transport xconnect 10.22.22.22 333 pw-class fratmip interface POS1/0 ip address 10.1.7.3 255.255.255.0 crc 32 clock source internal mpls ip mpls label protocol ldp router ospf 10 passive-interface Loopback0 network 10.33.33.33 0.0.0.0 area 10 network 10.1.7.0 0.0.0.255 area 10 </pre>	<pre> ip cef mpls ip mpls label protocol ldp mpls ldp router-id loopback0 force pseudowire-class fratmip encapsulation mpls interworking ip interface Loopback0 ip address 10.22.22.22 255.255.255.255 interface ATM 2/0 pvc 0/203 l2transport encapsulation aa5snap xconnect 10.33.33.33 333 pw-class fratmip interface POS1/0 ip address 10.1.1.2 255.255.255.0 crc 32 clock source internal mpls ip mpls label protocol ldp router ospf 10 passive-interface Loopback0 network 10.22.22.22 0.0.0.0 area 10 network 10.1.1.0 0.0.0.255 area 10 </pre>

VLAN to ATM AAL5 over AToM (Bridged): Example

The following example shows the configuration of VLAN to ATM AAL5 over AToM:

PE1	PE2
<pre> ip cef ! mpls ip mpls label protocol ldp mpls ldp router-id Loopback0 ! pseudowire-class inter-ether encapsulation mpls interworking ethernet ! interface Loopback0 ip address 10.8.8.8 255.255.255.255 ! interface ATM1/0.1 point-to-point pvc 0/100 l2transport encapsulation aal5snap xconnect 10.9.9.9 123 pw-class inter-ether ! interface FastEthernet1/0 xconnect 10.9.9.9 1 pw-class inter-ether ! router ospf 10 log-adjacency-changes network 10.8.8.8 0.0.0.0 area 0 network 10.1.1.1 0.0.0.0 area 0 </pre>	<pre> ip cef ! mpls ip mpls label protocol ldp mpls ldp router-id Loopback0 ! pseudowire-class inter-ether encapsulation mpls interworking ethernet ! interface Loopback0 ip address 10.9.9.9 255.255.255.255 ! interface FastEthernet0/0 no ip address ! interface FastEthernet0/0.1 encapsulation dot1Q 10 xconnect 10.8.8.8 123 pw-class inter-ether ! router ospf 10 log-adjacency-changes network 10.9.9.9 0.0.0.0 area 0 network 10.1.1.2 0.0.0.0 area 0 </pre>

Frame Relay to PPP over L2TPv3 (Routed): Example

The following example shows the configuration of Frame Relay to PPP over L2TPv3:

PE1	PE2
<pre> ip cef ip routing ! ! ! pseudowire-class ppp-fr encapsulation l2tpv3 interworking ip ip local interface Loopback0 ! interface Loopback0 ip address 10.1.1.1 255.255.255.255 ! interface FastEthernet1/0/0 ip address 10.16.1.1 255.255.255.0 ! interface Serial3/0/0 no ip address encapsulation ppp ppp authentication chap ! ip route 10.0.0.0 255.0.0.0 10.16.1.2 ! xconnect 10.2.2.2 1 pw-class ppp-fr ppp ipcp address proxy 10.65.32.14 </pre>	<pre> ip cef ip routing ! ! frame-relay switching ! pseudowire-class ppp-fr encapsulation l2tpv3 interworking ip ip local interface Loopback0 ! interface Loopback0 ip address 10.2.2.2 255.255.255.255 ! interface FastEthernet1/0/0 ip address 10.16.2.1 255.255.255.0 ! interface Serial3/0/0 no ip address encapsulation frame-relay frame-relay intf-type dce ! ip route 10.0.0.0 255.0.0.0 10.16.2.2 ! connect ppp-fr Serial3/0/0 100 l2transport xconnect 10.1.1.1 100 pw-class ppp-fr </pre>

Frame Relay to PPP over AToM (Routed): Example

The following example shows the configuration of Frame Relay to PPP over AToM:

PE1	PE2
<pre> ip cef ip routing mpls label protocol ldp mpls ldp router-id loopback0 force ! ! ! pseudowire-class ppp-fr encapsulation mpls interworking ip ip local interface Loopback0 ! interface Loopback0 ip address 10.1.1.1 255.255.255.255 ! interface FastEthernet1/0/0 ip address 10.16.1.1 255.255.255.0 mpls ip label protocol ldp ! interface Serial3/0/0 no ip address encapsulation ppp ppp authentication chap xconnect 10.2.2.2 1 pw-class ppp-fr ppp ipcp address proxy 10.65.32.14 ! ip route 10.0.0.0 255.0.0.0 10.16.1.2 </pre>	<pre> ip cef ip routing mpls label protocol ldp mpls ldp router-id loopback0 force ! ! frame-relay switching ! pseudowire-class ppp-fr encapsulation mpls interworking ip ip local interface Loopback0 ! interface Loopback0 ip address 10.2.2.2 255.255.255.255 ! ! interface FastEthernet1/0/0 ip address 10.16.2.1 255.255.255.0 mpls ip mpls label protocol ldp ! ! interface Serial3/0/0 no ip address encapsulation frame-relay frame-relay intf-type dce ! ! ip route 10.0.0.0 255.0.0.0 10.16.2.2 ! ! connect ppp-fr Serial3/0/0 100 l2transport xconnect 10.1.1.1 100 pw-class ppp-fr </pre>

Ethernet/VLAN to PPP over AToM (Routed): Example

The following example shows the configuration of Ethernet VLAN to PPP over AToM:

PE1	PE2
<pre> configure terminal mpls label protocol ldp mpls ldp router-id Loopback0 mpls ip ! pseudowire-class ppp-ether encapsulation mpls interworking ip ! interface Loopback0 ip address 10.8.8.8 255.255.255.255 no shutdown ! interface POS2/0/1 no ip address encapsulation ppp no peer default ip address ppp ipcp address proxy 10.10.10.1 xconnect 10.9.9.9 300 pw-class ppp-ether no shutdown </pre>	<pre> configure terminal mpls label protocol ldp mpls ldp router-id Loopback0 mpls ip ! pseudowire-class ppp-ether encapsulation mpls interworking ip ! interface Loopback0 ip address 10.9.9.9 255.255.255.255 no shutdown ! interface vlan300 mtu 4470 no ip address xconnect 10.8.8.8 300 pw-class ppp-ether no shutdown ! interface GigabitEthernet6/2 switchport switchport trunk encapsulation dot1q switchport trunk allowed vlan 300 switchport mode trunk no shut </pre>

Additional References

The following sections provide references related to the L2VPN Interworking feature.

Related Documents

Related Topic	Document Title
Layer 2 Tunnel Protocol Version 3	Layer 2 Tunnel Protocol Version 3
Any Transport over MPLS	Any Transport over MPLS
Cisco 12000 series router shared port adaptors	Cisco 12000 Series Router SIP and SPA Software Configuration Guide, 12.0(32)S

Standards

Standards	Title
draft-ietf-l2tpext-l2tp-base-03.txt	Layer Two Tunneling Protocol (Version 3) 'L2TPv3'
draft-martini-l2circuit-trans-mpls-09.txt	Transport of Layer 2 Frames Over MPLS

Standards	Title
draft-ietf-pwe3-frame-relay-03.txt.	<i>Encapsulation Methods for Transport of Frame Relay over MPLS Networks</i>
draft-martini-l2circuit-encap-mpls-04.txt.	<i>Encapsulation Methods for Transport of Layer 2 Frames Over IP and MPLS Networks</i>
draft-ietf-pwe3-ethernet-encap-08.txt.	<i>Encapsulation Methods for Transport of Ethernet over MPLS Networks</i>
draft-ietf-pwe3-hdlc-ppp-encap-mpls-03.txt.	<i>Encapsulation Methods for Transport of PPP/HDLC over MPLS Networks</i>
draft-ietf-ppvpn-l2vpn-00.txt.	<i>An Architecture for L2VPNs</i>

MIBs

MIBs	MIBs Link
No new or modified MIBs are supported by this feature, and support for existing MIBs has not been modified by this feature.	To locate and download MIBs for selected platforms, Cisco IOS releases, and feature sets, use Cisco MIB Locator found at the following URL: http://www.cisco.com/go/mibs

RFCs

RFCs	Title
No new or modified RFCs are supported by this feature, and support for existing RFCs has not been modified by this feature.	—

Technical Assistance

Description	Link
The Cisco Technical Support & Documentation website contains thousands of pages of searchable technical content, including links to products, technologies, solutions, technical tips, tools, and technical documentation. Registered Cisco.com users can log in from this page to access even more content.	http://www.cisco.com/techsupport

Command Reference

This section documents new and modified commands.

- [debug frame-relay pseudowire](#)
- [debug ssm](#)
- [interworking](#)
- [mtu](#)
- [show l2tun session](#)
- [show l2tun tunnel](#)
- [show mpls l2transport vc](#)

debug frame-relay pseudowire

To display events and error conditions that occur when binding a Frame Relay data-link connection identifier (DLCI) to a pseudowire, use the **debug frame-relay pseudowire** command in privileged EXEC mode. To disable the display of these events and error conditions, use the **no** form of this command.

debug frame-relay pseudowire

no debug frame-relay pseudowire

Syntax Description This command contains no arguments or keywords.

Defaults DLCI events and errors are not displayed.

Command Modes Privileged EXEC

Command History	Release	Modification
	12.0(26)S	This command was introduced.
	12.2(25)S	This command was integrated into Cisco IOS Release 12.2(25)S.
	12.2(33)SRA	This command was integrated into Cisco IOS Release 12.2(33)SRA.
	12.4(11)T	This command was integrated into Cisco IOS Release 12.4(11)T.

Usage Guidelines The following are examples of Frame Relay pseudowire events:

- Command-line interface (CLI) provisioning events
- Pseudowire circuit status updates
- Failures occurring during the management of these events

Examples The following example enables the display of Frame Relay pseudowire events. In this example, the interface has been shut down and then enabled.

```
Router# debug frame-relay pseudowire
Router(config)# interface hss11/0/0
Router(config-if)# shutdown

09:18:33.303: FRoPW [10.15.15.15, 100]: acmgr_circuit_down
09:18:33.303: FRoPW [10.15.15.15, 100]: SW AC update circuit state to down
09:18:33.303: FRoPW [10.15.15.15, 100]: Setting connection DOWN
09:18:35.299: %LINK-5-CHANGED: Interface Hss11/0/0, changed state to administratively down
09:18:36.299: %LINEPROTO-5-UPDOWN: Line protocol on Interface Hss11/0/0, changed state to down

Router(config-if)# no shutdown
```

```

09:18:41.919: %LINK-3-UPDOWN: Interface Hss11/0/0, changed state to up
09:18:41.919: FRoPW [10.15.15.15, 100]: Local up, sending acmgr_circuit_up
09:18:41.919: FRoPW [10.15.15.15, 100]: Setting pw segment UP
09:18:41.919: FRoPW [10.15.15.15, 100]: PW nni_pvc_status set ACTIVE
09:18:41.919: label_oce_get_label_bundle: flags 14 label 28
09:18:42.919: %LINEPROTO-5-UPDOWN: Line protocol on Interface Hss11/0/0, changed state to
up

```

Table 5 describes the significant fields shown in the display.

Table 5 *debug frame-relay pseudowire Field Descriptions*

Field	Description
Time (09.18.41)	When the event occurred (in hours, minutes, and seconds).
[10.15.15.15, 100]	10.15.15.15 is the IP address of the peer provider edge (PE) router. 100 is the DLCI number of the Frame Relay permanent virtual circuit (PVC) used for this pseudowire.

debug ssm

To display diagnostic information about the Segment Switching Manager (SSM) for switched Layer 2 segments, use the **debug ssm** command in privileged EXEC mode. To disable debugging, use the **no** form of this command.

```
debug ssm { cm errors | cm events | fhm errors | fhm events | sm errors | sm events | sm counters
           | xdr }
```

```
no debug ssm { cm errors | cm events | fhm errors | fhm events | sm errors | sm events | sm
              counters | xdr }
```

Syntax Description

cm errors	Displays Connection Manager (CM) errors.
cm events	Displays CM events.
fhm errors	Displays Feature Handler Manager (FHM) errors.
fhm events	Displays FHM events.
sm errors	Displays Segment Handler Manager (SM) errors.
sm events	Displays SM events.
sm counters	Displays SM counters.
xdr	Displays external data representation (XDR) messages related to traffic sent across the backplane between Router Processors and line cards.

Defaults

SSM events and errors are not displayed.

Command Modes

Privileged EXEC

Command History

Release	Modification
12.0(26)S	This command was introduced.
12.2(25)S	This command was integrated into Cisco IOS Release 12.2(25)S.
12.2(28)SB	This command was integrated into Cisco IOS Release 12.2(28)SB.
12.2(33)SRA	This command was integrated into Cisco IOS Release 12.2(33)SRA.
12.4(11)T	This command was integrated into Cisco IOS Release 12.4(11)T.

Usage Guidelines

The SSM manages the data-plane component of the Layer 2 Virtual Private Network (L2VPN) configuration. The CM tracks the connection-level errors and events that occur on an xconnect. The SM tracks the per-segment events and errors on the xconnect.

Use the **debug ssm** command to troubleshoot problems in bringing up the data plane.

This command is generally used only by Cisco engineers for internal debugging of SSM processes.

Examples

The following example shows sample output for the **debug ssm xdr** command:

```
Router# debug ssm xdr

SSM xdr debugging is on

2w5d: SSM XDR: [4096] deallocate segment, len 16
2w5d: SSM XDR: [8193] deallocate segment, len 16
2w5d: %LINK-3-UPDOWN: Interface FastEthernet2/1, changed state to down
2w5d: %LINK-3-UPDOWN: Interface FastEthernet2/1, changed state to up
2w5d: SSM XDR: [4102] provision segment, switch 4101, len 106
2w5d: SSM XDR: [4102] update segment status, len 17
2w5d: SSM XDR: [8199] provision segment, switch 4101, len 206
2w5d: SSM XDR: [4102] update segment status, len 17
2w5d: %SYS-5-CONFIG_I: Configured from console by console
2w5d: %LINK-3-UPDOWN: Interface FastEthernet2/1, changed state to down
2w5d: SSM XDR: [4102] update segment status, len 17
2w5d: %LINK-3-UPDOWN: Interface FastEthernet2/1, changed state to up
2w5d: SSM XDR: [4102] deallocate segment, len 16
2w5d: SSM XDR: [8199] deallocate segment, len 16
2w5d: SSM XDR: [4104] provision segment, switch 4102, len 106
2w5d: SSM XDR: [4104] update segment status, len 17
2w5d: SSM XDR: [8201] provision segment, switch 4102, len 206
2w5d: SSM XDR: [4104] update segment status, len 17
2w5d: SSM XDR: [4104] update segment status, len 17
2w5d: %SYS-5-CONFIG_I: Configured from console by console
```

The following example shows the events that occur on the segment manager when an Any Transport over MPLS (AToM) virtual circuit (VC) configured for Ethernet over MPLS is shut down and then enabled:

```
Router# debug ssm sm events

SSM Connection Manager events debugging is on

Router(config)# interface fastethernet 0/1/0.1
Router(config-subif)# shutdown

09:13:38.159: SSM SM: [SSS:AToM:36928] event Unprovison segment
09:13:38.159: SSM SM: [SSS:Ethernet Vlan:4146] event Unbind segment
09:13:38.159: SSM SM: [SSS:AToM:36928] free segment class
09:13:38.159: SSM SM: [SSS:AToM:36928] free segment
09:13:38.159: SSM SM: [SSS:AToM:36928] event Free segment
09:13:38.159: SSM SM: last segment class freed
09:13:38.159: SSM SM: [SSS:Ethernet Vlan:4146] segment ready
09:13:38.159: SSM SM: [SSS:Ethernet Vlan:4146] event Found segment data

Router(config-subif)# no shutdown

09:13:45.815: SSM SM: [SSS:AToM:36929] event Provison segment
09:13:45.815: label_oce_get_label_bundle: flags 14 label 16
09:13:45.815: SSM SM: [SSS:AToM:36929] segment ready
09:13:45.815: SSM SM: [SSS:AToM:36929] event Found segment data
09:13:45.815: SSM SM: [SSS:AToM:36929] event Bind segment
09:13:45.815: SSM SM: [SSS:Ethernet Vlan:4146] event Bind segment
```

The following example shows the events that occur on the CM when an AToM VC configured for Ethernet over MPLS is shut down and then enabled:

```
Router(config)# interface fastethernet 0/1/0.1
Router(config-subif)# shutdown

09:17:20.179: SSM CM: [AToM] unprovision segment, id 36929
09:17:20.179: SSM CM: CM FSM: state Open - event Free segment
09:17:20.179: SSM CM: [SSS:AToM:36929] unprovision segment 1
```

```

09:17:20.179: SSM CM: [SSS:AToM] shQ request send unprovision complete event
09:17:20.179: SSM CM: [SSS:Ethernet Vlan:4146] unbind segment 2
09:17:20.179: SSM CM: [SSS:Ethernet Vlan] shQ request send ready event
09:17:20.179: SSM CM: SM msg event send unprovision complete event
09:17:20.179: SSM CM: SM msg event send ready event

```

```
Router(config-subif)# no shutdown
```

```

09:17:35.879: SSM CM: Query AToM to Ethernet Vlan switching, enabled
09:17:35.879: SSM CM: [AToM] provision second segment, id 36930
09:17:35.879: SSM CM: CM FSM: state Down - event Provision segment
09:17:35.879: SSM CM: [SSS:AToM:36930] provision segment 2
09:17:35.879: SSM CM: [AToM] send client event 6, id 36930
09:17:35.879: SSM CM: [SSS:AToM] shQ request send ready event
09:17:35.883: SSM CM: SM msg event send ready event
09:17:35.883: SSM CM: [AToM] send client event 3, id 36930

```

The following example shows the events that occur on the CM and SM when an AToM VC is provisioned and then unprovisioned:

```
Router# debug ssm cm events
```

```
SSM Connection Manager events debugging is on
```

```
Router# debug ssm sm events
```

```
SSM Segment Manager events debugging is on
```

```
Router# configure terminal
```

```
Router(config)# interface ethernet1/0
```

```
Router(config-if)# xconnect 10.55.55.2 101 pw-class mpls
```

```

16:57:34: SSM CM: provision switch event, switch id 86040
16:57:34: SSM CM: [Ethernet] provision first segment, id 12313
16:57:34: SSM CM: CM FSM: state Idle - event Provision segment
16:57:34: SSM CM: [SSS:Ethernet:12313] provision segment 1
16:57:34: SSM SM: [SSS:Ethernet:12313] event Provision segment
16:57:34: SSM CM: [SSS:Ethernet] shQ request send ready event
16:57:34: SSM CM: SM msg event send ready event
16:57:34: SSM SM: [SSS:Ethernet:12313] segment ready
16:57:34: SSM SM: [SSS:Ethernet:12313] event Found segment data
16:57:34: SSM CM: Query AToM to Ethernet switching, enabled
16:57:34: SSM CM: [AToM] provision second segment, id 16410
16:57:34: SSM CM: CM FSM: state Down - event Provision segment
16:57:34: SSM CM: [SSS:AToM:16410] provision segment 2
16:57:34: SSM SM: [SSS:AToM:16410] event Provision segment
16:57:34: SSM CM: [AToM] send client event 6, id 16410
16:57:34: label_oce_get_label_bundle: flags 14 label 19
16:57:34: SSM CM: [SSS:AToM] shQ request send ready event
16:57:34: SSM CM: SM msg event send ready event
16:57:34: SSM SM: [SSS:AToM:16410] segment ready
16:57:34: SSM SM: [SSS:AToM:16410] event Found segment data
16:57:34: SSM SM: [SSS:AToM:16410] event Bind segment
16:57:34: SSM SM: [SSS:Ethernet:12313] event Bind segment
16:57:34: SSM CM: [AToM] send client event 3, id 16410

```

```
Router# configure terminal
```

```
Router(config)# interface e1/0
```

```
Router(config-if)# no xconnect
```

```

16:57:26: SSM CM: [Ethernet] unprovision segment, id 16387
16:57:26: SSM CM: CM FSM: state Open - event Free segment
16:57:26: SSM CM: [SSS:Ethernet:16387] unprovision segment 1
16:57:26: SSM SM: [SSS:Ethernet:16387] event Unprovision segment

```

```

16:57:26: SSM CM: [SSS:Ethernet] shQ request send unprovision complete event
16:57:26: SSM CM: [SSS:AToM:86036] unbind segment 2
16:57:26: SSM SM: [SSS:AToM:86036] event Unbind segment
16:57:26: SSM CM: SM msg event send unprovision complete event
16:57:26: SSM SM: [SSS:Ethernet:16387] free segment class
16:57:26: SSM SM: [SSS:Ethernet:16387] free segment
16:57:26: SSM SM: [SSS:Ethernet:16387] event Free segment
16:57:26: SSM SM: last segment class freed
16:57:26: SSM CM: unprovision switch event, switch id 12290
16:57:26: SSM CM: [SSS:AToM] shQ request send unready event
16:57:26: SSM CM: SM msg event send unready event
16:57:26: SSM SM: [SSS:AToM:86036] event Unbind segment
16:57:26: SSM CM: [AToM] unprovision segment, id 86036
16:57:26: SSM CM: CM FSM: state Down - event Free segment
16:57:26: SSM CM: [SSS:AToM:86036] unprovision segment 2
16:57:26: SSM SM: [SSS:AToM:86036] event Unprovison segment
16:57:26: SSM CM: [SSS:AToM] shQ request send unprovision complete event
16:57:26: SSM CM: SM msg event send unprovision complete event
16:57:26: SSM SM: [SSS:AToM:86036] free segment class
16:57:26: SSM SM: [SSS:AToM:86036] free segment
16:57:26: SSM SM: [SSS:AToM:86036] event Free segment
16:57:26: SSM SM: last segment class freed

```

Related Commands

Command	Description
show ssm	Displays SSM information for switched Layer 2 segments.

interworking

To enable the L2VPN Interworking feature, use the **interworking** command in pseudowire class configuration mode. To disable the L2VPN Interworking feature, use the **no** form of this command.

interworking { **ethernet** | **ip** }

no interworking { **ethernet** | **ip** }

Syntax Description	ethernet	ip
	Causes Ethernet frames to be extracted from the attachment circuit and sent over the pseudowire. Ethernet end-to-end transmission is assumed. Attachment circuit frames that do not contain Ethernet frames are dropped. In the case of VLAN, the VLAN tag is removed, leaving a pure Ethernet frame.	Causes IP packets to be extracted from the attachment circuit and sent over the pseudowire. Attachment circuit frames that do not contain IPv4 packets are dropped.

Defaults L2VPN Interworking is not enabled.

Command Modes Pseudowire class configuration

Command History	Release	Modification
	12.0(26)S	This command was introduced.
	12.2(25)S	This command was integrated into Cisco IOS Release 12.2(25)S.
	12.2(33)SRA	This command was integrated into Cisco IOS Release 12.2(33)SRA.
	12.4(11)T	This command was integrated into Cisco IOS Release 12.4(11)T.

Usage Guidelines [Table 6](#) shows which L2VPN Interworking features support Ethernet, IP, or both types of interworking.

Table 6 L2VPN Interworking Feature Support

L2VPN Interworking Feature	IP Interworking Support?	Ethernet Interworking Support?
Frame Relay to PPP	Yes	No
Frame Relay to ATM AAL5	Yes	No
Ethernet/VLAN to ATM AAL5	Yes	Yes
Ethernet/VLAN to Frame Relay	Yes	Yes
Ethernet/VLAN to PPP	Yes	No
Ethernet to VLAN	Yes	Yes

Examples

The following example shows a pseudowire class configuration that enables the L2VPN Interworking feature:

```
pseudowire-class ip-interworking
 encapsulation mpls
 interworking ip
```

Related Commands

Command	Description
encapsulation l2tpv3	Specifies that L2TPv3 is used as the data encapsulation method for tunneling IP traffic over the pseudowire.
encapsulation mpls	Specifies that MPLS is used as the data encapsulation method for tunneling Layer 2 traffic over the pseudowire.

mtu

To adjust the maximum packet size or maximum transmission unit (MTU) size, use the **mtu** command in interface configuration mode or connect submode. To restore the MTU value to its original default value, use the **no** form of this command.

mtu *bytes*

no mtu

Syntax Description

bytes MTU size, in bytes.

Defaults

Table 7 lists default MTU values according to media type.

Table 7 Default Media MTU Values

Media Type	Default MTU (Bytes)
Ethernet	1500
Serial	1500
Token Ring	4464
ATM	4470
FDDI	4470
HSSI (HSA)	4470

Command Modes

Interface configuration
Connect submode (for Frame Relay Layer 2 Interworking)

Command History

Release	Modification
10.0	This command was introduced.
12.0(26)S	This command was updated to support connect submode for Frame Relay Layer 2 Interworking.
12.2(33)SRA	This command was integrated into Cisco IOS Release 12.2(33)SRA.
12.4(11)T	This command was integrated into Cisco IOS Release 12.4(11)T.

Usage Guidelines

Each interface has a default maximum packet size or MTU size. This number generally defaults to the largest size possible for that interface type. On serial interfaces, the MTU size varies, but cannot be set to a value less than 64 bytes.



Note

Changing the MTU size is not supported on a loopback interface.

**Note**

Changing an MTU size on a Cisco 7500 series router results in the recarving of buffers and resetting of all interfaces. The following message is displayed:

```
%RSP-3-Restart:cbus complex.
```

**Note**

You can configure native Gigabit Ethernet ports on the Cisco 7200 series router to a maximum MTU size of 9216 bytes. The MTU values range from 1500 to 9216 bytes.

Protocol-Specific Versions of the mtu Command

Changing the MTU value with the **mtu** interface configuration command can affect values for the protocol-specific versions of the command (the **ip mtu** command, for example). If the value specified with the **ip mtu** interface configuration command is the same as the value specified with the **mtu** interface configuration command, and you change the value for the **mtu** interface configuration command, the **ip mtu** value automatically matches the new **mtu** interface configuration command value. However, changing the values for the **ip mtu** configuration commands has no effect on the value for the **mtu** interface configuration command.

ATM and LANE Interfaces

ATM interfaces are not bound by what is configured on the major interface. By default, MTU on a subinterface is equal to the default MTU (4490); if a client is configured the default is 1500. MTU can be changed on subinterfaces, but it may result in recarving of buffers to accommodate the new maximum MTU on the interface.

Examples

The following example specifies an MTU of 1000 bytes:

```
Router(config)# interface serial 1
Router(config-if)# mtu 1000
```

Related Commands

Command	Description
encapsulation smds	Enables SMDS service on the desired interface.
ip mtu	Sets the MTU size of IP packets sent on an interface.

show l2tun session

To display the current state of Layer 2 sessions and protocol information about Layer 2 Tunnel Protocol (L2TP) control channels, use the **show l2tun session** command in privileged EXEC mode.

```
show l2tun session [all [filter] | brief [filter] [hostname] | circuit [filter] [hostname] |
interworking [filter] [hostname] | packets [filter] | sequence [filter] | state [filter]]
```

Syntax Description		
all	(Optional) Displays information about all current L2TP sessions on the router.	
<i>filter</i>	(Optional) One of the filter parameters defined in Table 8 .	
brief	(Optional) Displays information about all current L2TP sessions, including peer ID address and circuit status of the L2TP sessions.	
hostname	(Optional) Specifies that the peer hostname will be displayed in the output.	
circuit	(Optional) Displays information about all current L2TP sessions, including circuit status (up or down).	
interworking	(Optional) Displays information about Layer 2 Virtual Private Network (L2VPN) interworking.	
packets	(Optional) Displays information about the packet counters (in and out) associated with current L2TP sessions.	
sequence	(Optional) Displays sequencing information about each L2TP session, including number of out-of-order and returned packets.	
state	(Optional) Displays information about all current L2TP sessions and their protocol state, including remote Virtual Connection Identifier (VCIDs).	

Command Modes Privileged EXEC

Command History	Release	Modification
	12.0(23)S	This command was introduced.
	12.3(2)T	This command was integrated into Cisco IOS Release 12.3(2)T.
	12.2(25)S	This command was integrated into Cisco IOS Release 12.2(25)S.
	12.0(31)S	The hostname keyword was added.
	12.2(27)SBC	This command was integrated into Cisco IOS Release 12.2(27)SBC.
	12.2(33)SRA	This command was integrated into Cisco IOS Release 12.2(33)SRA.
	12.4(11)T	This command was integrated into Cisco IOS Release 12.4(11)T.

Usage Guidelines Use the **show l2tun session** command to display information about current L2TP sessions on the router. [Table 8](#) defines the filter parameters available to refine the output of the **show l2tun session** command.

Table 8 Filter Parameters for the show l2tun session Command

Syntax	Description
ip-addr <i>ip-address</i> [vcid <i>number</i>]	Filters the output to display information about only those L2TP sessions associated with the IP address of the peer router. The 32-bit VCID shared between the peer router and the local router at each end of the control channel can optionally be specified. <ul style="list-style-type: none"> <i>ip-address</i>—IP address of the peer router. <i>number</i>—The VCID number.
vcid <i>number</i>	Filters the output to display information about only those L2TP sessions associated with the VCID shared between the peer router and the local router at each end of the control channel. <ul style="list-style-type: none"> <i>number</i>—The VCID number.
username <i>username</i>	Filters the output to display information for only those sessions associated with the specified username. <ul style="list-style-type: none"> <i>username</i>—The username.

Examples

The following example shows how to display detailed information about all current L2TP sessions:

```
Router# show l2tun session all

Session Information Total tunnels 0 sessions 1

Session id 42438 is down, tunnel id 45795
  Remote session id is 0, remote tunnel id 43092
Session Layer 2 circuit, type is Ethernet, name is FastEthernet4/1/1
  Session vcid is 123456789
  Circuit state is DOWN
    Local circuit state is DOWN
    Remote circuit state is DOWN
  Call serial number is 1463700128
  Remote tunnel name is PE1
    Internet address is 10.1.1.1
  Local tunnel name is PE1
    Internet address is 10.1.1.2
  IP protocol 115
  Session is L2TP signalled
  Session state is idle, time since change 00:00:26
    0 Packets sent, 0 received
    0 Bytes sent, 0 received
  Last clearing of "show vpdn" counters never
  Receive packets dropped:
    out-of-order:      0
    total:             0
  Send packets dropped:
    exceeded session MTU: 0
    total:             0
  DF bit off, ToS reflect disabled, ToS value 0, TTL value 255
  No session cookie information available
  UDP checksums are disabled
  L2-L2 switching enabled
  No FS cached header information available
  Sequencing is off
  Unique ID is 1
```

The following example shows how to display information only about the L2TP session set up on a peer router with an IP address of 172.16.184.142 and a VCID of 300:

```
Router# show l2tun session all ip-addr 172.16.184.142 vcid 300

L2TP Session
Session id 32518 is up, tunnel id 35217
Call serial number is 2074900020
Remote tunnel name is tun1
  Internet address is 172.16.184.142
Session is L2TP signalled
  Session state is established, time since change 03:06:39
    9932 Packets sent, 9932 received
    1171954 Bytes sent, 1171918 received
  Session vcid is 300
  Session Layer 2 circuit, type is Ethernet Vlan, name is FastEthernet0/1/0.3:3
  Circuit state is UP
    Remote session id is 18819, remote tunnel id 37340
  Set DF bit to 0
  Session cookie information:
    local cookie, size 4 bytes, value CF DC 5B F3
    remote cookie, size 4 bytes, value FE 33 56 C4
  SSS switching enabled
  Sequencing is on
    Ns 9932, Nr 10001, 0 out of order packets discarded
```

Table 9 describes the significant fields shown in the displays.

Table 9 show l2tun session Field Descriptions

Field	Description
Total tunnels	Total number of L2TP tunnels currently established on the router.
sessions	Number of L2TP sessions currently established on the router.
Session id	Session ID for established sessions.
is	Session state.
tunnel id	Tunnel ID for established tunnels.
Remote session id	Session ID for the remote session.
Remote tunnel id	Tunnel ID for the remote tunnel.
Session Layer 2 circuit type is, name is	Type and name of the interface used for the Layer 2 circuit.
Session vcid is	VCID of the session.
Circuit state is	State of the Layer 2 circuit.
Local circuit state is	State of the local circuit.
Remote circuit state is	State of the remote circuit.
Call serial number is	Call serial number.
Remote tunnel name is	Name of the remote tunnel.
Internet address is	IP address of the remote tunnel.
Local tunnel name is	Name of the local tunnel.
Internet address is	IP address of the local tunnel.

Table 9 show l2tun session Field Descriptions (continued)

Field	Description
IP protocol	The IP protocol used.
Session is	Signaling type for the session.
Session state is	Session state for the session.
time since change	Time since the session state last changed, in the format hh:mm:ss.
Packets sent, received	Number of packets sent and received since the session was established.
Bytes sent, received	Number of bytes sent and received since the session was established.
Last clearing of “show vpdn” counters	Time elapsed since the last clearing of the counters displayed with the show vpdn command. Time will be displayed in one of the following formats: <ul style="list-style-type: none"> • hh:mm:ss—Hours, minutes, and seconds. • dd:hh—Days and hours. • WwDd—Weeks and days, where W is the number of weeks and D is the number of days. • YyWw—Years and weeks, where Y is the number of years and W is the number of weeks. • never—The timer has not been started.
Receive packets dropped:	Number of received packets that were dropped since the session was established. <ul style="list-style-type: none"> • out-of-order—Number of received packets that were dropped because they were out of order. • total—Total number of received packets that were dropped.
Send packets dropped:	Number of sent packets that were dropped since the session was established. <ul style="list-style-type: none"> • exceeded session MTU—Number of sent packets that were dropped because the session maximum transmission unit (MTU) was exceeded. • total—Total number of sent packets that were dropped.
DF bit	Status of the Don't Fragment (DF) bit option. The DF bit can be on or off.
ToS reflect	Status of the type of service (ToS) reflect option. ToS reflection can be enabled or disabled.
ToS value	Value of the ToS byte in the L2TP header.
TTL value	Value of the time-to-live (TTL) byte in the L2TP header.
local cookie	Size (in bytes) and value of the local cookie.
remote cookie	Size (in bytes) and value of the remote cookie.
UDP checksums are switching	Status of User Datagram Protocol (UDP) checksum configuration.
No FS cached header information available	Fast Switching (FS) cached header information. If an FS header is configured, the encapsulation size and hexadecimal contents of the FS header will be displayed. The FS header is valid only for IP virtual private dialup network (VPDN) traffic from a tunnel server to a network access server (NAS).
Sequencing is	Status of sequencing. Sequencing can be on or off.
Ns	Sequence number for sending.

Table 9 *show l2tun session Field Descriptions (continued)*

Field	Description
Nr	Sequence number for receiving.
Unique ID is	Global user ID correlator.

The following example shows how to display information about the circuit status of L2TP sessions on a router:

```
Router# show l2tun session circuit

Session Information Total tunnels 3 sessions 3

LocID      TunID      Peer-address  Type Stat Username, Intf/
                Vcid, Circuit
32517      26515      172.16.184.142  VLAN UP 100, Fa0/1/0.1:1
32519      30866      172.16.184.142  VLAN UP 200, Fa0/1/0.2:2
32518      35217      172.16.184.142  VLAN UP 300, Fa0/1/0.3:3
```

The following example shows how to display information about the circuit status of L2TP sessions and the hostnames of remote peers:

```
Router# show l2tun session circuit hostname

Session Information Total tunnels 3 sessions 3

LocID      TunID      Peer-hostname Type Stat Username, Intf/
                Vcid, Circuit
32517      26515      <unknown>      VLAN UP 100, Fa0/1/0.1:1
32519      30866      router32        VLAN UP 200, Fa0/1/0.2:2
32518      35217      access3         VLAN UP 300, Fa0/1/0.3:3
```

[Table 10](#) describes the significant fields shown in the displays.

Table 10 *show l2tun session circuit Field Descriptions*

Field	Description
LocID	Local session ID.
TunID	Tunnel ID.
Peer-address	IP address of the peer.
Peer-hostname	Hostname of the peer.
Type	Session type.
Stat	Session status.
Username, Intf/Vcid, Circuit	Username, interface name/VCID, and circuit number of the session.

Related Commands

Command	Description
show l2tun	Displays general information about Layer 2 tunnels and sessions.
show l2tun tunnel	Displays the current state of Layer 2 tunnels and information about configured tunnels.

show l2tun tunnel

To display the current state of Layer 2 Tunneling Protocol (L2TP) tunnels and information about configured tunnels, including local and remote hostnames, aggregate packet counts, and control channel information, use the **show l2tun tunnel** command in privileged EXEC mode.

Cisco IOS Release 12.0(30)S and Earlier Releases, Cisco IOS Release 12.3(2)T and Later Releases, Cisco IOS Release 12.2(25)S, Cisco IOS Release 12.2(28)SB

```
show l2tun tunnel [all [filter] | packets [filter] | state [filter] | summary [filter] | transport [filter]]
```

Cisco IOS Release 12.0(31)S and Later Releases, Cisco IOS Release 12.2(27)SBC, Cisco IOS Release 12.2(33)SRA

```
show l2tun tunnel [all [filter] | packets [filter] | state [filter] | summary [filter] | transport [filter] | authentication]
```

Syntax Description		
all	(Optional) Displays information about all current L2TP sessions configured on the router.	
<i>filter</i>	(Optional) One of the filter parameters defined in Table 11 .	
packets	(Optional) Displays aggregate packet counts for all negotiated L2TP sessions.	
state	(Optional) Displays information about the current state of L2TP sessions, including the local and remote hostnames for each control channel.	
summary	(Optional) Displays a summary of L2TP sessions on the router and their current state, including the number of virtual private dialup network (VPDN) sessions associated with each control channel.	
transport	(Optional) Displays information about the L2TP control channels used in each session and the local and remote IP addresses at each end of the control channel.	
authentication	(Optional) Displays global information about L2TP control channel authentication attribute-value pairs (AV pairs).	

Command Modes	
	Privileged EXEC

Command History	Release	Modification
	12.0(23)S	This command was introduced.
	12.3(2)T	This command was integrated into Cisco IOS Release 12.3(2)T.
	12.2(25)S	This command was integrated into Cisco IOS Release 12.2(25)S.
	12.0(30)S	This command was enhanced to display information about pseudowire control channel authentication passwords.
	12.0(31)S	The authentication keyword was added and the output of the show l2tun tunnel all command was enhanced to display per-tunnel authentication failure counters.
	12.2(27)SBC	This command was integrated into Cisco IOS Release 12.2(27)SBC.

Release	Modification
12.2(28)SB	The authentication keyword was removed. The statistics previously displayed by the show l2tun tunnel authentication command are now displayed by the show l2tun counters tunnel l2tp authentication command.
12.2(33)SRA	This command was integrated into Cisco IOS Release 12.2(33)SRA.
12.4(11)T	This command was integrated into Cisco IOS Release 12.4(11)T.

Usage Guidelines

Use the **show l2tun tunnel** command to display information about configured L2TP sessions on the router.

[Table 11](#) defines the filter parameters available to refine the output of the **show l2tun tunnel** command.

Table 11 Filter Parameters for the show l2tun tunnel Command

Syntax	Description
id <i>local-id</i>	Filters the output to display information for only the tunnel with the specified local ID. <ul style="list-style-type: none"> <i>local-id</i>—The local tunnel ID number. Valid values range from 1 to 65535.
local-name <i>local-name</i> <i>remote-name</i>	Filters the output to display information for only the tunnel associated with the specified names. <ul style="list-style-type: none"> <i>local-name</i>—The local tunnel name. <i>remote-name</i>—The remote tunnel name.
remote-name <i>remote-name</i> <i>local-name</i>	Filters the output to display information for only the tunnel associated with the specified names. <ul style="list-style-type: none"> <i>remote-name</i>—The remote tunnel name. <i>local-name</i>—The local tunnel name.

Examples

The following example shows how to display detailed information about all L2TP tunnels:

```
Router# show l2tun tunnel all

Tunnel Information Total tunnels 1 sessions 1

Tunnel id 26515 is up, remote id is 41814, 1 active sessions
  Tunnel state is established, time since change 03:11:50
  Tunnel transport is IP (115)
  Remote tunnel name is tun1
    Internet Address 172.16.184.142, port 0
  Local tunnel name is Router
    Internet Address 172.16.184.116, port 0
  Tunnel domain is
  VPDN group for tunnel is
  L2TP class for tunnel is
  0 packets sent, 0 received
  0 bytes sent, 0 received
  Control Ns 11507, Nr 11506
  Local RWS 2048 (default), Remote RWS 800
  Tunnel PMTU checking disabled
```

```

Retransmission time 1, max 1 seconds
Unsent queuesize 0, max 0
Resend queuesize 1, max 1
Total resends 0, ZLB ACKs sent 11505
Total peer authentication failures 8
Current nosession queue check 0 of 5
Retransmit time distribution: 0 0 0 0 0 0 0 0
Sessions disconnected due to lack of resources 0

```

The following example shows the display of pseudowire control channel password information:

```

Router# show l2tun tunnel all
!
Control message authentication is on, 2 secrets configured
Last message authenticated with first digest secret
!

```

Table 12 describes the significant fields shown in the displays.

Table 12 *show l2tun tunnel all Field Descriptions*

Field	Description
Total tunnels	Total number of L2TP tunnels currently established on the router.
sessions	Number of L2TP sessions currently established on the router.
Tunnel id is up	Tunnel ID and tunnel status.
remote id is	Remote ID.
active sessions	Number of active sessions.
Tunnel state is	State of the tunnel.
time since change	Time since the tunnel state last changed, in the format hh:mm:ss.
Tunnel transport is	Tunnel transport protocol.
Remote tunnel name is	Name of the remote tunnel endpoint.
Internet Address	IP address of the remote tunnel endpoint.
port	Port number used by the remote tunnel endpoint.
Local tunnel name is	Name of the local tunnel endpoint.
Internet Address	IP address of the local tunnel endpoint.
port	Port number used by the local tunnel endpoint.
Tunnel domain is	Domain information for the tunnel.
VPDN group for tunnel is	Name of the VPDN group associated with the tunnel.
L2TP class for tunnel is	Name of the L2TP class associated with the tunnel.
packets sent, received	Number of packets sent and received since the tunnel was established.
bytes sent, received	Number of bytes sent and received since the tunnel was established.
Control Ns, Nr	Sequence number for control packets sent and received.
Local RWS	Local receiving window size, in packets.
Remote RWS	Remote receiving window size, in packets.

Table 12 *show l2tun tunnel all Field Descriptions (continued)*

Field	Description
Tunnel PMTU checking	Status of the tunnel path maximum transmission unit (MTU) checking option. It may be enabled or disabled.
Retransmission time, max	Current time, in seconds, required to resend a packet and maximum time, in seconds, that was required to resend a packet since tunnel establishment.
Unsent queuesize, max	Current size of the unsent queue and maximum size of the unsent queue since tunnel establishment.
Resend queuesize, max	Current size of the resend queue and maximum size of the resend queue since tunnel establishment.
Total resends	Total number of packets re-sent since tunnel establishment.
Total peer authentication failures	The total number of times peer authentication has failed.
ZLB ACKs sent	Number of zero length body acknowledgment messages sent.
Current nosession queue check	Number of tunnel timeout periods since the last session ended. Up to five tunnel timeouts are used if there are outstanding control packets on the unsent or resend queue. Otherwise, the tunnel is dropped after one tunnel timeout.
Retransmit time distribution	Histogram showing the number of retransmissions at 0, 1, 2,..., 8 seconds, respectively.
Sessions disconnected due to lack of resources	Number of sessions disconnected because of a lack of available resources.
Control message authentication is	Specifies whether pseudowire control message authentication is on or off for the tunnel.
secrets configured	The number of pseudowire control channel authentication passwords that are configured for the tunnel. One or two passwords may be configured.
Last message authenticated with	The password that was used to authenticate the last pseudowire control channel message. The control channel message may be authenticated with the first digest secret or with the second digest secret.

The following example shows how to filter information to display L2TP control channel details only for the sessions configured with the local name Router and the remote name tun1:

```
Router# show l2tun tunnel transport local-name Router tun1

Tunnel Information Total tunnels 3 sessions 3

LocID Type Prot Local Address Port Remote Address Port
26515 IP 115 172.16.184.116 0 172.16.184.142 0
30866 IP 115 172.16.184.116 0 172.16.184.142 0
35217 IP 115 172.16.184.116 0 172.16.184.142 0
```

[Table 13](#) describes the significant fields shown in the display.

Table 13 *show l2tun tunnel transport Field Descriptions*

Field	Description
Total tunnels	Total number of tunnels currently established.
sessions	Number of sessions currently established.
LocID	Local session ID.
Type	Session type.
Prot	Protocol type used by the tunnel.
Local Address	IP address of the local tunnel endpoint.
Port	Port used by the local tunnel endpoint.
Remote Address	IP address of the remote tunnel endpoint.
Port	Port used by the remote tunnel endpoint.

The following example shows how to display information about the current state of L2TP sessions with the local and remote hostnames of each session:

```
Router# show l2tun tunnel state

LocID  RemID   Local Name Remote Name  State  Last-Chg
26515  41814   Router    tun1         est    03:13:15
30866  6809    Router    tun1         est    03:13:15
35217  37340   Router    tun1         est    03:13:15
```

Table 14 describes the significant fields shown in the display.

Table 14 *show l2tun tunnel state Field Descriptions*

Field	Description
LocID	Local session ID.
RemID	Remote session ID.
Local Name	Name of the local tunnel endpoint.
Remote Name	Name of the remote tunnel endpoint.
State	Current state of the tunnel.
Last-Chg	Time since the state of the tunnel last changed, in the format hh:mm:ss.

The following example shows the display of all possible L2TP control channel authentication AV pair statistics. AV pair statistic fields are displayed only if they are nonzero. For the purposes of this example, all possible output fields are displayed in the sample output.

This example is valid for Cisco IOS Release 12.0(31)S and later releases or Cisco IOS Release 12.2(27)SBC. To display authentication statistics in Cisco IOS Release 12.2(28)SB or a later release, use the **monitor l2tun counters tunnel l2tp** and **show l2tun counters tunnel l2tp** commands instead.

```
Router# show l2tun tunnel authentication

L2TPv3 Tunnel Authentication Statistics:
  Nonce AVP Statistics:
    Ignored                0
    Missing                 0
```

```

All Digests Statistics:
  Unexpected                               0
  Unexpected ZLB                           0
Primary Digest AVP Statistics:
  Validate fail                             0
  Hash invalid                              0
  Length invalid                            0
  Missing                                   0
  Ignored                                   0
  Passed                                    0
  Failed                                    0
Secondary Digest AVP Statistics:
  Validate fail                             0
  Hash invalid                              0
  Length invalid                            0
  Missing                                   0
  Ignored                                   0
  Passed                                    0
  Failed                                    0
Integrity Check Statistics:
  Validate fail                             0
  Length invalid                            0
  Passed                                    0
  Failed                                    0
Local Secret Statistics:
  Missing                                   0
Challenge AVP Statistics:
  Generate response fail                    0
  Ignored                                   0
Challenge/Response AVP Statistics:
  Generate response fail                    0
  Missing                                   0
  Ignored                                   0
  Passed                                    0
  Failed                                    0
Overall Statistics:
  Passed                                    0
  Skipped                                   0
  Ignored                                   0
  Failed                                    0

```

Table 15 describes the significant fields shown in the display.

Table 15 *show l2tun tunnel authentication Field Descriptions*

Field	Description
Nonce AVP Statistics	Counters for the nonce AV pair.
Ignored	Number of AV pair messages that were ignored.
Missing	Number of AV pair messages that were missing.
All Digests Statistics	Statistics for all configured digest passwords.
Unexpected	Digest information was received but the router is not configured for it.
Unexpected ZLB	A Zero Length Body (ZLB) message was received while control message authentication is enabled. ZLB messages are permitted only when control message authentication is disabled.
Primary Digest AVP Statistics	Statistics for AV pair messages exchanged using the primary L2TP Version 3 (L2TPv3) control message digest password.
Validate fail	Number of AV pair messages that failed to validate.

Table 15 *show l2tun tunnel authentication Field Descriptions (continued)*

Field	Description
Hash invalid	Number of AV pair messages with an invalid hash.
Length invalid	Number of AV pair messages with an invalid length.
Passed	Number of AV pair messages successfully exchanged.
Failed	Number of AV pair messages that have failed to authenticate.
Secondary Digest AVP Statistics	Statistics for AV pair messages exchanged using the secondary L2TPv3 control message digest password.
Integrity Check Statistics	Statistics for AV pair messages exchanged when integrity checking is enabled.
Local Secret Statistics	Statistics for AV pair messages related to the local secret.
Challenge AVP Statistics	Statistics for AV pair messages related to Challenge Handshake Authentication Protocol (CHAP) style authentication challenges.
Generate response fail	Number of AV pair messages that did not generate a response.
Challenge/Response AVP Statistics	Statistics for AV pair messages exchanged when CHAP-style authentication is configured.
Overall Statistics	Summary of the statistics for all authentication AV pair messages.
Skipped	The number of AV pair messages that authentication was not performed on.

Related Commands

Command	Description
clear l2tun counters tunnel l2tp	Clears global or per-tunnel control message statistics for L2TP tunnels.
clear l2tun tunnel counters	Clears L2TP control channel authentication counters.
monitor l2tun counters tunnel l2tp	Enables or disables the collection of per-tunnel control message statistics for L2TP tunnels.
show l2tun	Displays general information about Layer 2 tunnels and sessions.
show l2tun session	Displays the current state of Layer 2 sessions and displays protocol information about L2TP control channels.
show l2tun counters tunnel l2tp	Displays global or per-tunnel control message statistics for L2TP tunnels, or toggles the recording of per-tunnel statistics for a specific tunnel.

show mpls l2transport vc

To display information about Any Transport over MPLS (AToM) virtual circuits (VCs) that have been enabled to route Layer 2 packets on a router, use the **show mpls l2transport vc** command in privileged EXEC mode.

```
show mpls l2transport vc {[vcid vc-id] | [vcid vc-id-min vc-id-max]} [interface name
[local-circuit-id]] [destination ip-address | name] [detail]
```

Syntax Description	
vcid	(Optional) Allows you to enter a specific VC ID to display.
<i>vc-id</i>	(Optional) The VC ID number.
<i>vc-id-min</i> <i>vc-id-max</i>	(Optional) Allows you to enter a range of VCs to display. The range is from 1 to 4294967295. (This argument is primarily used for legacy implementations.)
interface	(Optional) The interface or subinterface of the router that has been enabled to transport Layer 2 packets. This keyword lets you display information about the VCs that have been assigned VC IDs on that interface or subinterface.
<i>name</i>	(Optional) The name of the interface or subinterface.
<i>local-circuit-id</i>	(Optional) The number assigned to the local circuit. This argument value is supported only to the following transport types: <ul style="list-style-type: none"> For Frame Relay, enter the data-link connection identifier (DLCI) of the permanent virtual circuit (PVC). For ATM adaptation layer 5 (AAL5) and cell relay, enter the virtual path identifier (VPI)/virtual channel identifier (VCI) of the PVC. For Ethernet VLANs, enter the VLAN number.
destination	(Optional) Information about the VCs that have been assigned VC IDs for the remote router you specify.
<i>ip-address</i>	(Optional) The IP address of the remote router.
<i>name</i>	(Optional) The name assigned to the remote router.
detail	(Optional) Detailed information about the VCs that have been assigned VC IDs.

Command Modes Privileged EXEC

Command History	Release	Modification
	12.1(8a)E	This command was introduced.
	12.0(21)ST	This command was integrated into Cisco IOS Release 12.0(21)ST.
	12.0(22)S	This command was implemented on the Cisco 10720 router.
	12.0(23)S	The interface and destination keywords were added.
	12.2(14)S	This command was integrated into Cisco IOS Release 12.2(14)S.
	12.2(14)SX	This command was implemented on the Supervisor Engine 720.
	12.2(14)SZ	This command was integrated into Cisco IOS Release 12.2(14)SZ.
	12.2(15)T	This command was integrated into Cisco IOS Release 12.2(15)T.

12.2(18)S	This command was implemented on Cisco 7304 routers.
12.0(25)S	This command was updated with new output and fields to display information about tunnel selection and ATM cell relay port mode.
12.2(17d)SXB	Support for this command on the Supervisor Engine 2 was extended to Release 12.2 SX.
12.2(25)S	This command was updated with new output and fields for nonstop forwarding (NSF), stateful switchover (SSO), and graceful restart (GR) abilities.
12.2(28)SB	This command was implemented on the Cisco 10000 series routers. Example output was changed for the Cisco 10000 series router, and two fields (SSO Descriptor and SSM segment/switch IDs) were removed from the output, because they are not supported.
12.2(33)SRA	This command was integrated into Cisco IOS Release 12.2(33)SRA.
12.4(11)T	This command was integrated into Cisco IOS Release 12.4(11)T.

Usage Guidelines

If you do not specify any keywords or arguments, the command displays a summary of all the VCs.

Examples

The output of the commands varies, depending on the type of Layer 2 packets being transported over the AToM VCs.

The following sample output shows information about the interfaces and VCs that have been configured to transport various Layer 2 packets on the router:

```
Router# show mpls l2transport vc
```

```
Local intf      Local circuit    Dest address    VC ID           Status
-----
Se5/0          FR DLCI 55      10.0.0.1       55              UP
AT4/0          ATM AAL5 0/100  10.0.0.1       100             UP
AT4/0          ATM AAL5 0/200  10.0.0.1       200             UP
AT4/0.300      ATM AAL5 0/300  10.0.0.1       300             UP
```

Table 16 describes the fields shown in the display.

Table 16 *show mpls l2transport vc Field Descriptions*

Field	Description
Local intf	The interface on the local router that has been enabled to transport Layer 2 packets.
Local circuit	The type and number (if applicable) of the local circuit. The output shown in this column varies, depending on the transport type: <ul style="list-style-type: none"> For Frame Relay, the output shows the DLCI of the PVC. For ATM cell relay and AAL5, the output shows the VPI/VCI of the PVC. For Ethernet VLANs, the output shows the VLAN number. For PPP and High-Level Data Link Control (HDLC), the output shows the interface number.

Table 16 show mpls l2transport vc Field Descriptions (continued)

Field	Description
Dest address	The IP address of the remote router's interface that is the other end of the VC.
VC ID	The virtual circuit identifier assigned to one of the interfaces on the router.
Status	<p>The status of the VC. The status can be one of the following:</p> <ul style="list-style-type: none"> • UP—The VC is in a state where it can carry traffic between the two VC endpoints. A VC is up when both imposition and disposition interfaces are programmed. <ul style="list-style-type: none"> – The disposition interface is programmed if the VC has been configured and the client interface is up. – The imposition interface is programmed if the disposition interface is programmed and you have a remote VC label and an Interior Gateway Protocol (IGP) label. The IGP label can be implicit null in a back-to-back configuration. An IGP label means there is a Label Switched Path (LSP) to the peer. • DOWN—The VC is not ready to carry traffic between the two VC endpoints. Use the detail keyword to determine the reason that the VC is down. • ADMIN DOWN—The VC has been disabled by a user. • RECOVERING—The VC is recovering from a stateful switchover.

The following example shows information about the NSF/SSO and graceful restart capability. The SSO portion indicates when checkpointing data has either been sent (on active) or received (on standby). When SSO data has not been successfully sent or has been released, the SSO information is not shown.

```
Router# show mpls l2transport vc detail

Local interface: Fa5/1/1.2 down, line protocol down, Eth VLAN 2 up
  Destination address: 10.55.55.2, VC ID: 1002, VC status: down
    Output interface: Se4/0/3, imposed label stack {16}
      Preferred path: not configured
      Default path: active
      Tunnel label: imp-null, next hop point2point
    Create time: 02:03:29, last status change time: 02:03:26
  Signaling protocol: LDP, peer 10.55.55.2:0 down
    MPLS VC labels: local 16, remote unassigned
      Group ID: local 0, remote unknown
      MTU: local 1500, remote unknown
    Remote interface description:
  Sequencing: receive disabled, send disabled
  SSO Descriptor: 10.55.55.2/1002, local label: 16
    SSM segment/switch IDs: 12290/8193, PWID: 8193
  VC statistics:
    packet totals: receive 0, send 0
    byte totals:   receive 0, send 0
    packet drops:  receive 0, send 0
```

Table 17 describes the significant fields shown in the display.

Table 17 *show mpls l2transport vc detail Field Descriptions*

Field	Description
Local interface	Interface on the local router that has been enabled to send and receive Layer 2 packets. The interface varies, depending on the transport type. The output also shows the status of the interface.
line protocol	Status of the line protocol on the edge-facing interface.
Destination address	IP address of the remote router specified for this VC. You specify the destination IP address as part of the mpls l2transport route command.
VC ID	Virtual circuit identifier assigned to the interface on the router.
VC status	<p>Status of the VC, which is one of the following:</p> <p>UP—The VC is in a state where it can carry traffic between the two VC endpoints. A VC is up when both imposition and disposition interfaces are programmed.</p> <ul style="list-style-type: none"> The disposition interface is programmed if the VC has been configured and the client interface is up. The imposition interface is programmed if the disposition interface is programmed and a remote VC label and an IGP label exist. The IGP label can be an implicit null in a back-to-back configuration. (An IGP label means there is an LSP to the peer.) <p>DOWN—The VC is not ready to carry traffic between the two VC endpoints.</p> <p>ADMIN DOWN—The VC has been disabled by a user.</p>
Output interface	Interface on the remote router that has been enabled to transmit and receive Layer 2 packets.
imposed label stack	Summary of the MPLS label stack used to direct the VC to the PE router.
Preferred path	Path that was assigned to the VC and the status of that path. The path can be a Multiprotocol Label Switching (MPLS) traffic engineering tunnel or an IP address or hostname of a peer provider edge (PE) router.
Default path	<p>Status of the default path, which can be disabled or active.</p> <p>By default, if the preferred path fails, the router uses the default path. However, you can disable the router from using the default path when the preferred path fails by specifying the disable-fallback keyword with the preferred-path command.</p>

Table 17 *show mpls l2transport vc detail Field Descriptions (continued)*

Field	Description
Tunnel label	<p>An IGP label used to route the packet over the MPLS backbone to the destination router with the egress interface. The first part of the output displays the type of label. The second part of output displays the route information.</p> <p>The tunnel label information can display any of the following states:</p> <ul style="list-style-type: none"> • imp-null: The provider (P) router is absent and the tunnel label will not be used. Alternatively, imp-null can signify traffic engineering tunnels between the PE routers. • unassigned: The label has not been assigned. • no route: The label is not in the routing table. • no adjacency: The adjacency for the next hop is missing. • not ready, no route: An IP route for the peer does not exist in the routing table. • not ready, not a host table: The route in the routing table for the remote peer router is not a host route. • not ready, Cisco Express Forwarding disabled: Cisco Express Forwarding is disabled. • not ready, LFIB disabled: The MPLS switching subsystem is disabled. • not ready, label forwarding information base (LFIB) entry present: The tunnel label exists in the LFIB, but the VC is down.
Create time	Time when the VC was provisioned.
last status change time	Last time the VC state changed.
Signaling protocol	Type of protocol used to send the MPLS labels. The output also shows the status of the peer router.
MPLS VC labels	Local VC label is a disposition label, which determines the egress interface of an arriving packet from the MPLS backbone. The remote VC label is a disposition VC label of the remote peer router.
Group ID	Local group ID is used to group VCs locally. The remote group ID is used by the peer to group several VCs.
MTU	Maximum transmission unit specified for the local and remote interfaces.
Remote interface description	Interface on the remote router that has been enabled to transmit and receive Layer 2 packets.
Sequencing	Indicates whether sequencing of out-of-order packets is enabled or disabled.
SSO Descriptor	Identifies the VC for which the information was checkpointed.
local label	The value of the local label that was checkpointed (that is, sent on the active Route Processor [RP], and received on the standby RP).

Table 17 *show mpls l2transport vc detail Field Descriptions (continued)*

Field	Description
SSM segment/switch IDs	The IDs used to refer to the control plane and data plane contexts for this VC. This data is not for customer use but for Cisco personnel for troubleshooting purposes. When the source specific multicast (SSM) IDs are followed by the word “used,” the checkpointed data has been successfully sent and not released.
PWID	The pseudowire ID used in the data plane to correlate the switching context for the segment mentioned with the MPLS switching context. This data is not for customer use but for Cisco personnel for troubleshooting purposes.
packet totals	Number of packets sent and received. Received packets are those AToM packets received from the MPLS core. Sent packets are those AToM packets sent to the MPLS core. This does not include dropped packets.
byte totals	Number of bytes sent and received from the core-facing interface, including the payload, control word if present, and AToM VC label.
packet drops	Number of dropped packets.

Related Commands

Command	Description
show mpls l2transport summary	Displays summary information about VCs that have been enabled to route AToM Layer 2 packets on a router.

Feature Information for L2VPN Interworking

Table 18 lists the release history for this feature.

Not all commands may be available in your Cisco IOS software release. For release information about a specific command, see the command reference documentation.

Cisco IOS software images are specific to a Cisco IOS software release, a feature set, and a platform. Use Cisco Feature Navigator to find information about platform support and Cisco IOS software image support. Access Cisco Feature Navigator at <http://www.cisco.com/go/fn>. You must have an account on Cisco.com. If you do not have an account or have forgotten your username or password, click **Cancel** at the login dialog box and follow the instructions that appear.



Note

Table 18 lists only the Cisco IOS software release that introduced support for a given feature in a given Cisco IOS software release train. Unless noted otherwise, subsequent releases of that Cisco IOS software release train also support that feature.

Table 18 Feature Information for L2VPN Interworking

Feature Name	Releases	Feature Information
L2VPN Interworking	12.0(26)S 12.0(30)S 12.0(32)S 12.0(32)SY 12.2(33)SRA 12.4(11)T	<p>This feature allows disparate attachment circuits to be connected. An interworking function facilitates the translation between the different Layer 2 encapsulations.</p> <p>This feature was introduced in Cisco IOS Release 12.0(26)S.</p> <p>In Cisco IOS Release 12.0(30)S, support was added for Cisco 12000 series Internet routers.</p> <p>In Cisco IOS Release 12.0(32)S, support was added on Engine 5 line cards (SIP-401, SIP-501, SIP-600, and SIP-601) in Cisco 12000 series routers for the following four transport types:</p> <ul style="list-style-type: none"> • Ethernet/VLAN to Frame Relay Interworking • Ethernet/VLAN to ATM AAL5 Interworking • Ethernet to VLAN Interworking • Frame Relay to ATM AAL5 Interworking <p>On the Cisco 12000 series Internet router, support was added for IP Services Engine (ISE) and Engine 5 line cards that are configured for L2TPv3 tunneling (see Layer 2 Tunnel Protocol Version 3).</p> <p>In Cisco IOS Release 12.2(33)SRA, support was added for the Cisco 7600 series routers.</p> <p>In Cisco IOS Release 12.4(11)T, support was added for the following transport types:</p> <ul style="list-style-type: none"> • Ethernet to VLAN Interworking • Ethernet/VLAN to Frame Relay Interworking <p>Use Cisco Feature Navigator to find information about platform support and Cisco IOS software image support.</p>

CCVP, the Cisco logo, and Welcome to the Human Network are trademarks of Cisco Systems, Inc.; Changing the Way We Work, Live, Play, and Learn is a service mark of Cisco Systems, Inc.; and Access Registrar, Aironet, Catalyst, CCDA, CCDP, CCIE, CCIP, CCNA, CCNP, CCSP, Cisco, the Cisco Certified Internetwork Expert logo, Cisco IOS, Cisco Press, Cisco Systems, Cisco Systems Capital, the Cisco Systems logo, Cisco Unity, Enterprise/Solver, EtherChannel, EtherFast, EtherSwitch, Fast Step, Follow Me Browsing, FormShare, GigaDrive, HomeLink, Internet Quotient, IOS, iPhone, IP/TV, iQ Expertise, the iQ logo, iQ Net Readiness Scorecard, iQuick Study, LightStream, Linksys, MeetingPlace, MGX, Networkers, Networking Academy, Network Registrar, PIX, ProConnect, ScriptShare, SMARTnet, StackWise, The Fastest Way to Increase Your Internet Quotient, and TransPath are registered trademarks of Cisco Systems, Inc. and/or its affiliates in the United States and certain other countries.

All other trademarks mentioned in this document or Website are the property of their respective owners. The use of the word partner does not imply a partnership relationship between Cisco and any other company. (0711R)

Any Internet Protocol (IP) addresses used in this document are not intended to be actual addresses. Any examples, command display output, and figures included in the document are shown for illustrative purposes only. Any use of actual IP addresses in illustrative content is unintentional and coincidental.

© 2003-2006 Cisco Systems, Inc. All rights reserved.

