



## PPPoE Session Limits per NAS Port

---

The PPPoE Session Limit per NAS Port feature enables you to limit the number of PPP over Ethernet (PPPoE) sessions on a specific permanent virtual circuit (PVC) or VLAN configured on an L2TP access concentrator (LAC). The network access server (NAS) port is either an ATM PVC or a configured VLAN ID. PPPoE per-NAS-port session limits are maintained in a RADIUS server customer profile database and are downloaded during Subscriber Service Switch (SSS) preauthorization.

### Feature History for the PPPoE Session Limits per NAS Port Feature

Release	Modification
12.2(15)B	This feature was introduced on the Cisco 7200 series and Cisco 7401ASR routers.
12.3(4)T	This feature was integrated into Cisco IOS Release 12.3(4)T.
12.2(27)SBA	This feature was integrated into Cisco IOS Release 12.2(27)SBA.

### Finding Support Information for Platforms and Cisco IOS Software Images

Use Cisco Feature Navigator to find information about platform support and Cisco IOS software image support. Access Cisco Feature Navigator at <http://www.cisco.com/go/fn>. You must have an account on Cisco.com. If you do not have an account or have forgotten your username or password, click **Cancel** at the login dialog box and follow the instructions that appear.

## Contents

- [Prerequisites for PPPoE Session Limits per NAS Port, page 2](#)
- [Restrictions for PPPoE Session Limits per NAS Port, page 2](#)
- [Information About PPPoE Session Limits per NAS Port, page 2](#)
- [How to Configure PPPoE Session Limits Per NAS Port, page 3](#)
- [Configuration Examples for PPPoE Session Limits per NAS Port, page 6](#)
- [Additional References, page 9](#)
- [Command Reference, page 10](#)



---

**Corporate Headquarters:**  
Cisco Systems, Inc., 170 West Tasman Drive, San Jose, CA 95134-1706 USA

Copyright © 2002, 2003, 2005 Cisco Systems, Inc. All rights reserved.

## Prerequisites for PPPoE Session Limits per NAS Port

Both the LAC and the L2TP Network Server (LNS) must be running a Cisco IOS image that supports the PPPoE Session Limit Per NAS Port feature.

## Restrictions for PPPoE Session Limits per NAS Port

- Do not configure the PPPoE per-NAS-port session limit to zero.
- PPPoE Session Limit per NAS Port does not support TACACS+.
- PPPoE Session Limit per NAS Port applies only to PVCs and VLANs.

## Information About PPPoE Session Limits per NAS Port

To configure per-NAS-port session limits for PPPoE, you should understand the following concepts:

- [How PPPoE per-NAS-Port Session Limits Work](#), page 2
- [Relationship Between the Per-NAS-Port Session Limit and Other Types of Session Limits](#), page 3
- [Benefits of PPPoE Session Limits per NAS Port](#), page 3

## How PPPoE per-NAS-Port Session Limits Work

The PPPoE Session Limit Per NAS Port feature limits the number of PPPoE sessions on a specific PVC or VLAN configured on an LAC. The NAS port is either an ATM PVC or a configured VLAN ID.

The PPPoE per-NAS-port session limit is maintained in a RADIUS server customer profile database. This customer profile database is connected to a LAC and is separate from the RADIUS server that the LAC and LNS use for the authentication and authorization of incoming users. See [Figure 1](#) for a sample network topology. When the customer profile database receives a preauthorization request from the LAC, it sends the PPPoE per-NAS-port session limit to the LAC.

The LAC sends a preauthorization request to the customer profile database when the LAC is configured for SSS preauthorization. When the LAC receives the PPPoE per-NAS-port session limit from the customer profile database, the LAC compares the PPPoE per-NAS-port session limit with the number of sessions currently on the NAS port. The LAC then decides whether to accept or reject the current call, depending upon the configured PPPoE per NAS port-session-limit and the number of calls currently on the NAS port.

Figure 1 PPPoE Session Limit per NAS Port Sample Topology

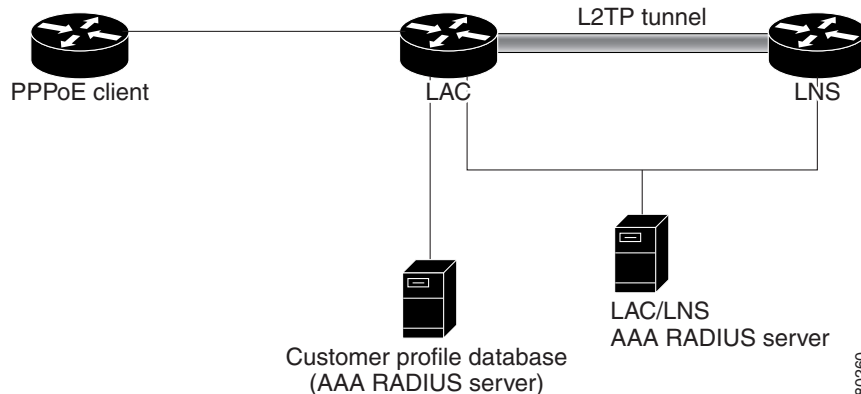

The customer profile database consists of user profiles for each user that is connected to the LAC. Each user profile contains the NAS-IP-Address (attribute 4) and the NAS-Port-ID (attribute 5.) When the LAC is configured for SSS preauthorization, it queries the customer profile database using the username. When a match is found in the customer profile database, the customer profile database sends the PPPoE per-NAS-port session limit in the user profile. The PPPoE per-NAS-port session limit is defined in the username as a Cisco AV-pair.

## Relationship Between the Per-NAS-Port Session Limit and Other Types of Session Limits

You can configure other types of session limits on the LAC, including session limit per VC, per VLAN, per MAC, and a global session limit for the LAC. When PPPoE Session Limit per NAS Port is enabled (that is, when you have enabled SSS preauthorization on the LAC), local configurations for session limit per VC and per VLAN are overwritten by the PPPoE per-NAS-port session limit downloaded from the customer profile database. Configured session limits per VC and per VLAN serve as backups in case of a download failure of the PPPoE per-NAS-port session limit. Global session limits and per-MAC session limits, if configured on the router, will take effect as other means of limiting PPPoE sessions.

## Benefits of PPPoE Session Limits per NAS Port

The PPPoE Session Limits per NAS Port feature provides flexibility and simplifies router configuration by allowing you to download the per-VC and per-VLAN session limits from a RADIUS server in addition to being able to configure them on the router.

## How to Configure PPPoE Session Limits Per NAS Port

This section contains the following procedures:

- [Enabling Subscriber Service Switch Preauthorization](#)
- [Configuring the RADIUS User Profile for PPPoE Session Limit Per NAS Port](#)
- [Verifying PPPoE Session Limit per NAS Port](#)

## Enabling Subscriber Service Switch Preauthorization

When Subscriber Service Switch preauthorization is enabled on a LAC, local configurations for session limit per VC and per VLAN are overwritten by the per-NAS-port session limit downloaded from the server. To enable this preauthorization, perform the following steps:

### SUMMARY STEPS

1. **enable**
2. **configure terminal**
3. **subscriber access pppoe pre-authorize nas-port-id [aaa-method-list]**
4. **exit**

### DETAILED STEPS

	Command or Action	Purpose
Step 1	<b>enable</b>  <b>Example:</b> Router> enable	Enables higher privilege levels, such as privileged EXEC mode. <ul style="list-style-type: none"> <li>• Enter your password if prompted.</li> </ul>
Step 2	<b>configure terminal</b>  <b>Example:</b> Router# configure terminal	Enters global configuration mode.
Step 3	<b>subscriber access pppoe pre-authorize nas-port-id [aaa-method-list]</b>  <b>Example:</b> Router(config)# subscriber access pppoe pre-authorize nas-port-id mlist_llid	Enables Subscriber Service Switch preauthorization. <ul style="list-style-type: none"> <li>• <i>aaa-method-list</i>—Name of a AAA authorization list configured on the LAC.</li> </ul> <div style="border: 1px solid black; padding: 2px; margin-top: 5px;">  <b>Note</b> During SSS preauthorization, per-NAS-port session limits are downloaded to the LAC.           </div>
Step 4	<b>exit</b>  <b>Example:</b> Router(config)# exit	Exits global configuration mode.

## Configuring the RADIUS User Profile for PPPoE Session Limit Per NAS Port

Table 1 lists the attributes to enable per-NAS-port PPPoE session limits in a RADIUS user profile for the customer profile database. Refer to the *Cisco IOS Security Configuration Guide*, for information about creating a RADIUS user profile.

**Table 1** Attributes for the RADIUS User Profile for Per-NAS-Port PPPoE Session Limits

RADIUS Entry	Purpose
User-Name = nas-port:ip-address:slot/subslot/port/vpi.vci	Configures the NAS port username for a PPPoE over ATM NAS port user. <ul style="list-style-type: none"> <li>• <i>ip-address</i>—IP address of the LAC interface that connects to the customer profile database.</li> <li>• <i>slot/subslot/port</i>—ATM interface.</li> <li>• <i>vpi.vci</i>—Virtual path identifier (VPI) and virtual channel identifier (VCI) values for the PVC.</li> </ul>
User-Name = nas-port:ip-address:slot/module/port/vlan-id	Configures the NAS port username for a PPPoE over VLAN NAS port user. <ul style="list-style-type: none"> <li>• <i>ip-address</i>—IP address of the LAC interface that connects to the customer profile database.</li> <li>• <i>slot/subslot/port</i>—ATM interface.</li> <li>• <i>vlan-id</i>—VLAN identifier.</li> </ul>
Password = "cisco"	Sets the fixed password.
cisco-avpair = "pppoe:session-limit=session limit per NAS-port"	Adds the PPPoE Session Limit per NAS Port Cisco AV-pair to the user profile. <ul style="list-style-type: none"> <li>• <i>session limit per NAS-port</i>—per-NAS-port PPPoE session limit.</li> </ul>

## Verifying PPPoE Session Limit per NAS Port

Perform this task to verify per-NAS-port session limit performance.

### SUMMARY STEPS

1. **enable**
2. **debug aaa authorization**
3. **debug radius [brief | hex]**

## DETAILED STEPS

	Command or Action	Purpose
Step 1	<code>enable</code>  <b>Example:</b> Router> enable	Enables privileged EXEC mode. <ul style="list-style-type: none"> <li>Enter your password if prompted.</li> </ul>
Step 2	<code>debug aaa authorization</code>  <b>Example:</b> Router# debug aaa authorization	Displays information on AAA authorization.
Step 3	<code>debug radius [brief   hex]</code>  <b>Example:</b> Router# debug radius	Displays information about RADIUS.

## Configuration Examples for PPPoE Session Limits per NAS Port

- [Configuring the LAC for per-NAS-Port Session Limits for PPPoE over ATM: Example, page 6](#)
- [Configuring the LAC for per-NAS-Port Session Limits for PPPoE over VLAN: Example, page 8](#)
- [Configuring the User Profile for PPPoE Session Limit per NAS Port: Example, page 9](#)

### Configuring the LAC for per-NAS-Port Session Limits for PPPoE over ATM: Example

The following example shows how to configure per-NAS-port session limits for PPPoE over ATM on the LAC:

```
!
username lac password 0 lab
username lns password 0 lab
aaa new-model
!
aaa authentication ppp default group radius local
aaa authentication ppp mlist_nasport group radius
aaa authorization network mlist_nasport group radius
aaa session-id common
ip subnet-zero
!
no ip domain lookup
ip host abrick 223.255.254.254
!
ip cef
subscriber access pppoe pre-authorize nas-port-id mlist_nasport
vpdn enable
!
vpdn-group l2tp_initiator
 request-dialin
  protocol l2tp
  domain nasport.com
```

```
initiate-to ip 10.1.1.2
local name lac
!
vpdn-group pppoe_terminate
accept-dialin
protocol pppoe
virtual-template 1
pppoe limit per-mac 10
pppoe limit per-vc 10
pppoe limit per-vlan 10
!
vc-class atm pppoe
protocol pppoe
ubr 155000
encapsulation aal5snap
!
interface ATM2/0
no ip address
no ip mroute-cache
no atm ilmi-keepalive
!
interface ATM2/0.1 point-to-point
class-int pppoe
pvc 1/100
encapsulation aal5snap
!
!
interface FastEthernet4/0
ip address 10.1.1.1 255.255.255.0
no ip mroute-cache
duplex full
!
interface FastEthernet6/0
ip address 220.1.1.3 255.255.255.0
no ip mroute-cache
duplex full
!
interface Virtual-Template1
ip unnumbered Loopback0
no peer default ip address
ppp authentication chap mlist_nasport
!
ip default-gateway 21.3.0.1
ip classless
ip route 0.0.0.0 0.0.0.0 21.3.0.1
!
!
ip radius source-interface FastEthernet6/0
!
radius-server host 220.1.1.2 auth-port 1645 acct-port 1646
radius-server key cisco
radius-server authorization permit missing Service-Type
!
```

## Configuring the LAC for per-NAS-Port Session Limits for PPPoE over VLAN: Example

The following example shows how to configure per-NAS-port session limits for PPPoE over VLAN on the LAC:

```

!
username lac password 0 lab
username lns password 0 lab
aaa new-model
!
!
aaa authentication ppp default group radius local
aaa authentication ppp mlist_nasport group radius
aaa authorization network mlist_nasport group radius
aaa session-id common
ip subnet-zero
!
!
no ip domain lookup
ip host abrick 223.255.254.254
!
ip cef
subscriber access pppoe pre-authorize nas-port-id mlist_nasport
vpdn enable
!
vpdn-group l2tp_initiator
 request-dialin
  protocol l2tp
  domain nasport.com
 initiate-to ip 10.1.1.2
 local name lac
!
vpdn-group pppoe_terminate
 accept-dialin
  protocol pppoe
  virtual-template 1
 pppoe limit per-mac 10
 pppoe limit per-vc 10
 pppoe limit per-vlan 10
!
vc-class atm pppoe
 protocol pppoe
 ubr 155000
 encapsulation aal5snap
!
interface ATM2/0
 no ip address
 no ip mroute-cache
 shutdown
 no atm ilmi-keepalive
!
interface FastEthernet4/0
 ip address 10.1.1.1 255.255.255.0
 no ip mroute-cache
 duplex full
!
interface FastEthernet6/0
 ip address 220.1.1.3 255.255.255.0
 no ip mroute-cache
 duplex full
!

```

```

interface Virtual-Template1
 ip unnumbered Loopback0
 no peer default ip address
 ppp authentication chap mlist_nasport
 !
 ip default-gateway 21.3.0.1
 ip classless
 ip route 0.0.0.0 0.0.0.0 21.3.0.1
 !
 !
 ip radius source-interface FastEthernet6/0
 !
 !
 radius-server host 220.1.1.2 auth-port 1645 acct-port 1646
 radius-server key cisco
 radius-server authorization permit missing Service-Type
 !
    
```

## Configuring the User Profile for PPPoE Session Limit per NAS Port: Example

The following example shows how to configure the user profile for PPPoE Session Limit per NAS port. In this example, the user has a PVC with a VPI of 1 and a VCI of 100 on ATM interface 4/0/0 of the LAC with an IP address of 10.10.10.10:

```

Username=nas_port:10.10.10.10:4/0/0/1.100
Password = "password1"
cisco-avpair= "pppoe:session-limit=<session limit per NAS-port>"
    
```

## Additional References

The following sections provide references related to the PPPoE Session Limits per NAS Port feature.

### Related Documents

Related Topic	Document Title
ATM PVC configuration	“ATM” chapter of the <i>Cisco IOS Wide-Area Networking Configuration Guide</i>
PPPoE and PPPoE over 802.1Q VLAN configuration	“Broadband Access: PPP and Routed Bridge Encapsulation” chapter of the <i>Cisco IOS Wide-Area Networking Configuration Guide</i>
PPPoE over VLAN enhancements	“PPPoE over VLAN Enhancements: Configuration Limit Removal and ATM Support,” Cisco IOS release 12.3(2)T new-feature document
ATM and PPPoE configuration commands	<i>Cisco IOS Wide-Area Networking Command Reference</i> , Cisco IOS Release 12.3(4)T

## Standards

Standards	Title
No new or modified standards are supported by this feature. Support for existing standards has not been modified by this feature.	—

## MIBs

MIBs	MIBs Link
No new or modified MIBs are supported by this feature. Support for existing MIBs has not been modified by this feature.	To locate and download MIBs for selected platforms, Cisco IOS releases, and feature sets, use Cisco MIB Locator found at the following URL:  <a href="http://www.cisco.com/go/mibs">http://www.cisco.com/go/mibs</a>

## RFCs

RFCs	Title
No new or modified RFCs are supported by this feature. Support for existing RFCs has not been modified by this feature.	—

## Technical Assistance

Description	Link
Technical Assistance Center (TAC) home page, containing 30,000 pages of searchable technical content, including links to products, technologies, solutions, technical tips, and tools. Registered Cisco.com users can log in from this page to access even more content.	<a href="http://www.cisco.com/public/support/tac/home.shtml">http://www.cisco.com/public/support/tac/home.shtml</a>

## Command Reference

.This section documents the modified command

- [subscriber access](#)

## subscriber access

To configure an L2TP access concentrator (LAC) to enable Subscriber Service Switch (SSS) to preauthorize the network access server (NAS) port identifier (NAS-Port-ID) string before authorizing the domain name, use the **subscriber access** command in global configuration mode. To disable SSS preauthorization, use the **no** form of this command.

```
subscriber access {pppoe | pppoa} pre-authorize nas-port-id [aaa-method-list]
```

```
no subscriber access {pppoe | pppoa} pre-authorize nas-port-id [aaa-method-list]
```

Syntax Description		
<b>pppoe</b>		Specifies PPP over Ethernet (PPPoE).
<b>pppoa</b>		Specifies PPP over ATM (PPPoA).
<b>pre-authorize nas-port-id</b>		Signals SSS to preauthorize the NAS-Port-ID string before authorizing the domain name.
<i>aaa-method-list</i>		(Optional) Authentication, authorization, and accounting (AAA) method list name.

**Defaults** Preauthorization is disabled.

**Command Modes** Global configuration

Command History	Release	Modification
	12.2(8)B	This command was introduced on the Cisco 6400 series, the Cisco 7200 series, and the Cisco 7401 ASR.
	12.2(13)T	This command was integrated into Cisco IOS Release 12.2(13)T and the <b>pppoe</b> and <b>pppoa</b> keywords were added.
	12.2(27)SBA	This command was integrated into Cisco IOS Release 12.2(27)SBA.

**Usage Guidelines** The NAS-Port-ID string is used to locate the first service record, which may contain one of three attributes, as follows:

- A restricted set of values for the domain substring of the unauthenticated PPP name.  
This filtered service key then locates the final service. See the **vpdn authorize domain** command for more information.
- PPPoE session limit.
- The logical line ID (LLID).

Once NAS port authorization has taken place, normal authorization, which is usually the domain authorization, continues.

### Logical Line ID

The LLID is an alphanumeric string of from 1 to 253 characters that serves as the logical identification of a subscriber line. LLID is maintained in a RADIUS server customer profile database and enables users to track their customers on the basis of the physical lines in which customer calls originate. Downloading the LLID is also referred to as *preauthorization* because it occurs before normal virtual private dialup network (VPDN) authorization downloads L2TP tunnel information.

This command enables LLID and SSS querying only for PPP over Ethernet over ATM (PPPoEoATM) and PPP over Ethernet over VLAN (PPPoEoVLAN or Dot1Q) calls; all other calls, such as ISDN, are not supported.

### Per-NAS-Port Session Limits for PPPoE

Use this command to configure SSS preauthorization on the LAC so that the PPPoE per-NAS-port session limit can be downloaded from the customer profile database. To use PPPoE per-NAS-port session limits, you must also configure the PPPoE Session-Limit per NAS-Port Cisco AV-pair in the user profile.

### Examples

The following example signals SSS to preauthorize the NAS-Port-ID string before authorizing the domain name. This policy applies only to sessions that have a PPPoE access type.

```

aaa new-model
aaa group server radius sg_llid
  server 172.20.164.106 auth-port 1645 acct-port 1646
aaa group server radius sg_water
  server 172.20.164.106 auth-port 1645 acct-port 1646
aaa authentication ppp default group radius
aaa authorization config-commands
aaa authorization network default group sg_water
aaa authorization network mlist_llid group sg_llid
aaa session-id common
!
username s7200_2 password 0 lab
username s5300 password 0 lab
username sg_water password 0 lab
vpdn enable
!
vpdn-group 2
  request-dialin
  protocol l2tp
  domain water.com
  initiate-to ip 10.1.1.1
  local name s7200_2
!
vpdn-group 3
  accept dialin
  protocol pppoe
  virtual-template 1
!
! Signals Subscriber Service Switch to preauthorize the NAS-Port-ID string before
! authorizing the domain name.
subscriber access pppoe pre-authorize nas-port-id mlist_llid
!
interface Loopback0
  ip address 10.1.1.2 255.255.255.0
!
interface Loopback1
  ip address 10.1.1.1 255.255.255.0
!
interface Ethernet1/0

```

```

ip address 10.2.2.2 255.255.255.0 secondary
ip address 10.0.58.111 255.255.255.0
no cdp enable
!
interface ATM4/0
no ip address
no atm ilmi-keepalive
!
interface ATM4/0.1 point-to-point
pvc 1/100
encapsulation aal5snap
protocol pppoe
!
interface virtual-templatel
no ip unnumbered Loopback0
no peer default ip address
ppp authentication chap
!
radius-server host 172.20.164.120 auth-port 1645 acct-port 1646 key rad123
radius-server host 172.20.164.106 auth-port 1645 acct-port 1646 key rad123
ip radius source-interface Loopback1
    
```

**Related Commands**

Command	Description
<b>subscriber authorization enable</b>	Enables SSS type authorization.
<b>vpdn authorize domain</b>	Enables domain preauthorization on a NAS.

CCVP, the Cisco logo, and Welcome to the Human Network are trademarks of Cisco Systems, Inc.; Changing the Way We Work, Live, Play, and Learn is a service mark of Cisco Systems, Inc.; and Access Registrar, Aironet, Catalyst, CCDA, CCDP, CCIE, CCIP, CCNA, CCNP, CCSP, Cisco, the Cisco Certified Internetwork Expert logo, Cisco IOS, Cisco Press, Cisco Systems, Cisco Systems Capital, the Cisco Systems logo, Cisco Unity, Enterprise/Solver, EtherChannel, EtherFast, EtherSwitch, Fast Step, Follow Me Browsing, FormShare, GigaDrive, HomeLink, Internet Quotient, IOS, iPhone, IP/TV, iQ Expertise, the iQ logo, iQ Net Readiness Scorecard, iQuick Study, LightStream, Linksys, MeetingPlace, MGX, Networkers, Networking Academy, Network Registrar, PIX, ProConnect, ScriptShare, SMARTnet, StackWise, The Fastest Way to Increase Your Internet Quotient, and TransPath are registered trademarks of Cisco Systems, Inc. and/or its affiliates in the United States and certain other countries.

All other trademarks mentioned in this document or Website are the property of their respective owners. The use of the word partner does not imply a partnership relationship between Cisco and any other company. (0711R)

Copyright © 2002, 2003, 2005 Cisco Systems, Inc. All rights reserved.

