



Configuring X.25 and LAPB

Last Updated: October 7, 2011

This chapter describes how to configure connections through Link Access Procedure, Balanced (LAPB) connections and X.25 networks. LAPB tasks are presented first for users who only want to configure a simple, reliable serial encapsulation method. For a complete description of the commands mentioned in this chapter, refer to the chapter "X.25 and LAPB Commands" in the *Cisco IOS Wide-Area Networking Command Reference*.

For information on the following related topics, see the corresponding Cisco publications:

Task	Resource
Configuring PAD access	"Configuring the Cisco PAD Facility for X.25 Connections" chapter in the <i>Cisco IOS Terminal Services Configuration Guide</i>
Translating between an X.25 PAD connection and another protocol	<i>Cisco IOS Terminal Services Command Reference</i> (commands in alphabetical order).
Configuring X.25 traffic over an ISDN D channel	"Configuring X.25 on ISDN" and "Configuring X.25 on ISDN using Always On/Direct ISDN (AO/DI)" chapters in the <i>Cisco IOS Dial Technologies Configuration Guide</i>
Referencing a complete list of Dial commands	<i>Cisco IOS Dial Technologies Command Reference</i> (commands in alphabetical order)

- [Finding Feature Information, page 1](#)
- [Information about LAPB and X.25, page 2](#)
- [How to Configure LAPB, page 34](#)
- [How to Configure X.25, page 37](#)
- [X.25 and LAPB Configuration Examples, page 71](#)

Finding Feature Information

Your software release may not support all the features documented in this module. For the latest feature information and caveats, see the release notes for your platform and software release. To find information



Americas Headquarters:
Cisco Systems, Inc., 170 West Tasman Drive, San Jose, CA 95134-1706 USA

about the features documented in this module, and to see a list of the releases in which each feature is supported, see the Feature Information Table at the end of this document.

Use Cisco Feature Navigator to find information about platform support and Cisco software image support. To access Cisco Feature Navigator, go to www.cisco.com/go/cfn. An account on Cisco.com is not required.

Information about LAPB and X.25

- [LAPB Overview](#), page 2
- [LAPB Data Compression](#), page 3
- [Modifying LAPB Protocol Parameters](#), page 3
- [Configuring Priority and Custom Queueing for LAPB](#), page 4
- [X.25 Interfaces](#), page 5
- [Asymmetrical Flow Control](#), page 9
- [X.25 Interface Parameters](#), page 9
- [X.25 Datagram Transport](#), page 11
- [Additional X.25 Datagram Transport Features](#), page 17
- [X.25 Routing](#), page 18
- [Additional X.25 Routing Features](#), page 19
- [DNS-Based X.25 Routing](#), page 21
- [X.25 over Frame Relay \(Annex G\)](#), page 24
- [CMNS Routing](#), page 24
- [Priority Queueing or Custom Queueing for X.25](#), page 24
- [X.25 Closed User Groups](#), page 25
- [DDN or BFE X.25](#), page 31
- [X.25 Remote Failure Detection](#), page 32
- [X.29 Access Lists](#), page 34

LAPB Overview

You use LAPB as a serial encapsulation method only if you have a private serial line. You must use one of the X.25 packet-level encapsulations when attaching to an X.25 network.

LAPB standards distinguish between the following two types of hosts:

- Data terminal equipment (DTE)
- Data circuit-terminating equipment (DCE)

At Level 2 (data link layer) in the OSI model, LAPB allows orderly and reliable exchange of data between a DTE and a DCE device. A router using LAPB encapsulation can act as a DTE or DCE at the protocol level, which is distinct from the hardware DTE or DCE identity.

Using LAPB under heavy traffic conditions can result in greater throughput than is possible using High-Level Data Link Control (HDLC) encapsulation. When LAPB detects a missing frame, the router resends the frame instead of waiting for the higher layers to recover the lost information. This behavior is useful only if the host timers are relatively slow. In the case of quickly expiring host timers, however, LAPB spends much time sending host retransmissions. If the line is not busy with data traffic, HDLC encapsulation is more efficient than LAPB. When long-delay satellite links are used, for example, the lockstep behavior of LAPB makes HDLC encapsulation the better choice.

LAPB Data Compression

You can configure point-to-point software compression on serial interfaces that use a LAPB or multi-LAPB encapsulation. Compression reduces the size of a LAPB or multi-LAPB frame via lossless data compression. Compression is performed in the software and can substantially affect system performance. You should disable compression if the router CPU load exceeds 65 percent. To display the CPU load, use the **show process cpu** command.

Predictor compression is recommended when the bottleneck is caused by the load on the router or access server. Stacker compression is recommended when the bottleneck is the result of line bandwidth. Compression is not recommended if the majority of your traffic is already compressed files. Compression is also not recommended for line speeds greater than T1. The added processing time slows performance on fast lines.

Modifying LAPB Protocol Parameters

LAPB specifies methods for exchanging data (frames), detecting out-of-sequence or missing frames, retransmitting frames, and acknowledging frames. Several protocol parameters can be modified to change LAPB protocol performance on a particular link. Because X.25 operates the Packet Level Protocol (PLP) on top of the LAPB protocol, these tasks apply to both X.25 links and LAPB links. The parameters and their default values are summarized in the table below. Detailed descriptions of each parameter are given after the table.

Table 1 **LAPB Parameters**

Command	Purpose (LAPB Parameter)	Values or Ranges	Default
lapb modulo <i>modulus</i>	Sets the modulo.	8 or 128	8
lapb k <i>window-size</i>	Sets the window size (K).	1- (modulo minus 1) frames	7
lapb n1 <i>bits</i>	Sets the maximum bits per frame (N1).	Bits (multiple of 8)	Based on hardware MTU and protocol overhead
lapb n2 <i>tries</i>	Sets the count for sending frames (N2).	1-255 tries	20
lapb t1 <i>milliseconds</i>	Sets the retransmission timer (T1).	1-64000 milliseconds	3000
lapb interface-outage <i>milliseconds</i>	Sets the hardware outage period.		0 (disabled)
lapb t4 <i>seconds</i>	Sets the idle link period (T4).		0 (disabled)

The following sections provide more information about the LAPB parameters in the table above:

- **LAPB modulo**--The LAPB modulo determines the operating mode. Modulo 8 (basic mode) is widely available because it is required for all standard LAPB implementations and is sufficient for most links. Modulo 128 (extended mode) can achieve greater throughput on high-speed links that have a low error rate (satellite links) by increasing the number of frames that can be sent before the sending device must wait for acknowledgment (as configured by LAPB parameter K).

- LAPB parameter K--LAPB K must be at most one less than the operating modulo. Modulo 8 links can send seven frames before an acknowledgment must be received by the sending device; modulo 128 links can send as many as 127 frames. By default, LAPB links use the basic mode with a window of 7.
- LAPB N1--When you configure a connection to an X.25 network, use the N1 parameter value set by the network administrator. This value is the maximum number of bits in a LAPB frame, which determines the maximum size of an X.25 packet. When you use LAPB over leased lines, the N1 parameter should be eight times the hardware MTU size plus any protocol overhead. The LAPB N1 range is dynamically calculated by the Cisco IOS software whenever an MTU change, a Layer 2/Layer 3 modulo change, or a compression change occurs on a LAPB interface.

**Caution**

The LAPB N1 parameter provides little benefit beyond the interface MTU, and can easily cause link failures if misconfigured. Cisco recommends that you leave this parameter at its default value.

- LAPB N2--The transmit counter (N2) is the number of unsuccessful transmit attempts that are made before the link is declared down.
- LAPB T1--The retransmission timer (T1) determines how long a sent frame can remain unacknowledged before the Cisco IOS software polls for an acknowledgment. For X.25 networks, the retransmission timer setting should match that of the network.

For leased-line circuits, the T1 timer setting is critical because the design of LAPB assumes that a frame has been lost if it is not acknowledged within period T1. The timer setting must be large enough to permit a maximum-sized frame to complete one round trip on the link. If the timer setting is too small, the software will poll before the acknowledgment frame can return, which may result in duplicated frames and severe protocol problems. If the timer setting is too large, the software waits longer than necessary before requesting an acknowledgment, slowing throughput.

- LAPB interface outage--Another LAPB timer function that allows brief hardware failures while the protocol is up, without requiring a protocol reset. When a brief hardware outage occurs, the link continues uninterrupted if the outage corrects before the specified outage period expires.
- LAPB T4--The LAPB standards define a timer to detect unsignaled link failures (T4). The T4 timer resets every time a frame is received from the partner on the link. If the T4 timer expires, a Receiver Ready frame with the Poll bit set is sent to the partner, which is required to respond. If the partner does not respond, the standard polling mechanism is used to determine whether the link is down. The period of T4 must be greater than the period of T1.

For an example of configuring the LAPB T1 timer, see the section "[Typical LAPB Configuration Example, page 72](#)".

Configuring Priority and Custom Queueing for LAPB

LAPB uses priority and custom queueing, which improves the responsiveness of a link to a given type of traffic by specifying the handling of that type of traffic for transmission on the link.

Priority queueing is a mechanism that classifies packets based on certain criteria and then assigns packets to one of four output queues, with high, medium, normal, or low priority.

Custom queueing similarly classifies packets, assigns them to one of ten output queues, and controls the percentage of the available bandwidth of an interface that is used for a queue.

For example, you can use priority queueing to ensure that all Telnet traffic is processed promptly and that Simple Mail Transfer Protocol (SMTP) traffic is sent only when there is no other traffic to send. Priority queueing in this example can starve the non-Telnet traffic; custom queueing can be used instead to ensure that some traffic of all categories is sent.

Both priority and custom queueing can be defined, but only one can be assigned to a given interface. To configure priority and custom queueing for LAPB, perform these tasks in the following order:

- 1 Perform standard priority and custom queueing tasks *except* the task of assigning a priority or custom group to the interface, as described in the chapters "Configuring Priority Queueing" and "Configuring Custom Queueing" in the *Cisco IOS Quality of Service Solutions Configuration Guide* .
- 2 Perform standard LAPB encapsulation tasks, as specified in the section "[Configuring a LAPB Datagram Transport, page 35](#)".
- 3 Assign either a priority group or a custom queue to the interface, as described in the chapters "Configuring Priority Queueing" and "Configuring Custom Queueing" in the *Cisco IOS Quality of Service Solutions Configuration Guide* .

The **lapb hold-queue** command is no longer supported, but the same functionality is provided by the standard queue control command **hold-queue size out**.

X.25 Interfaces

- [X.25 Encapsulation, page 5](#)
- [Virtual Circuit Ranges, page 5](#)
- [Packet-Numbering Modulo, page 6](#)
- [X.121 Address, page 7](#)
- [X.25 Switch Local Acknowledgment, page 7](#)
- [Flow Control Parameter Negotiation, page 7](#)
- [Default Flow Control Values, page 8](#)

X.25 Encapsulation

A router using X.25 Level 3 encapsulation can act as a DTE or DCE protocol device (according to the needs of your X.25 service supplier), can use DDN or BFE encapsulation, or can use the Internet Engineering Task Force (IETF) standard encapsulation, as specified by RFC 1356.

Because the default serial encapsulation is HDLC, you must explicitly configure an X.25 encapsulation method.



Note

We recommend that you use the **no encapsulation x25** command to remove all X.25 configurations from the interface before changing the encapsulation.

Typically a public data network (PDN) will require attachment as a DTE device. (This requirement is distinct from the hardware interface DTE or DCE identity.) The default mode is DTE, and the default encapsulation method is the Cisco pre-IETF method. If either DDN or BFE operation is needed, it must be explicitly configured. For an example of configuring X.25 DTE operation, see the section "[Typical X.25 Configuration Example, page 72](#)" later in this chapter.

Virtual Circuit Ranges

X.25 maintains multiple connections--virtual circuits (VCs) or logical circuits (LCs)--over one physical link between a DTE and a DCE device. X.25 can maintain up to 4095 VCs. A VC is identified by its logical channel identifier (LCI) or virtual circuit number (VCN).

**Note**

Many documents use the terms *virtual circuit* and *LC* , *VCN* , *LCN* , and *LCI* interchangeably. Each of these terms refers to the VC number.

An important part of X.25 operation is the range of VC numbers. These numbers are broken into the following four ranges:

- 1 Permanent virtual circuits (PVCs)
- 2 Incoming-only circuits
- 3 Two-way circuits
- 4 Outgoing-only circuits

The incoming-only, two-way, and outgoing-only ranges define the VC numbers over which a switched virtual circuit (SVC) can be established by the placement of an X.25 call, much as a telephone network establishes a switched voice circuit when a call is placed.

The rules about DCE and DTE devices initiating calls are as follows:

- Only the DCE can initiate a call in the incoming-only range.
- Only the DTE can initiate a call in the outgoing-only range.
- Both the DCE and DTE can initiate a call in the two-way range.

**Note**

The International Telecommunication Union-Telecommunication Standardization Sector (ITU-T) functions in place of the former Consultative Committee for International Telegraph and Telephone (CCITT). ITU-T *Recommendation X.25* defines "incoming" and "outgoing" in relation to the DTE or DCE interface role. Cisco documentation uses the more intuitive sense. Unless the ITU-T sense is explicitly referenced, a call received from the interface is an *incomingcall* and a call sent out to the interface is an *outgoingcall* .

There is no difference in the operation of SVCs in the different ranges except the restrictions on which device can initiate a call. These ranges can be used to prevent one side from monopolizing the VCs, which is important for X.25 interfaces with a small number of SVCs available. Six X.25 parameters define the upper and lower limit of each of the three SVC ranges. These ranges cannot overlap. A PVC must be assigned a number lower than those assigned to the SVC ranges.

**Note**

Because X.25 requires the DTE and DCE devices to have identical VC ranges, changes you make to the VC range limits when the interface is up are held until X.25 restarts the packet service.

Packet-Numbering Modulo

The Cisco implementation of X.25 supports modulo 8 (default) and modulo 128 packet sequence numbering.

**Note**

Because X.25 requires the DTE and DCE devices to have identical modulus, changes you make to the modulo when the interface is up remain until X.25 restarts the packet service.

The X.25 modulo and the LAPB modulo are distinct and serve different purposes. LAPB modulo 128 (or extended mode) can be used to achieve higher throughput across the DTE or DCE interface, which affects

only the local point of attachment. X.25 PLP modulo 128 can be used to achieve higher end-to-end throughput for VCs by allowing more data packets to be in transit across the X.25 network.

X.121 Address

If your router does not originate or terminate calls but only participates in X.25 switching, this task is optional. However, if your router is attached to a PDN, you must set the interface X.121 address assigned by the X.25 network service provider. Interfaces that use the DDN or BFE mode will have an X.121 address generated from the interface IP address; for correct DDN or BFE operation, any such X.121 address must not be modified.

X.25 Switch Local Acknowledgment

X.25 switch local acknowledgment allows you the choice of configuring local or end-to-end acknowledgment on your router. End-to-end acknowledgment can result in lower overall throughput and restrictive performance because an endpoint can only have a limited number of its packets in transit at any given time. End-to-end acknowledgment cannot send more packets until all have been acknowledged by the transmission and receipt of the delivery-confirming packet containing the D-bit.

Local acknowledgment means that the Cisco router can send acknowledgments for packets that do not have the D-bit set, before receiving an acknowledgment from the interface to which the packet was forwarded. This results in higher throughput of packets because acknowledgment is sent between local hops much faster and more efficiently than between end-to-end hops.

The figure below shows the Cisco router receiving packets from DTE A destined for DTE B. Without local acknowledgment enabled, the router forwards packets to the X.25 network and then forwards acknowledgments from the network back to DTE A. With local acknowledgment enabled, the router can acknowledge packets received from DTE A before it has received acknowledgments from the network for the forwarded packets. In this illustration, the X.25 network may also generate local acknowledgments.

Figure 1 Local Acknowledgment Between DTE A and DTE B

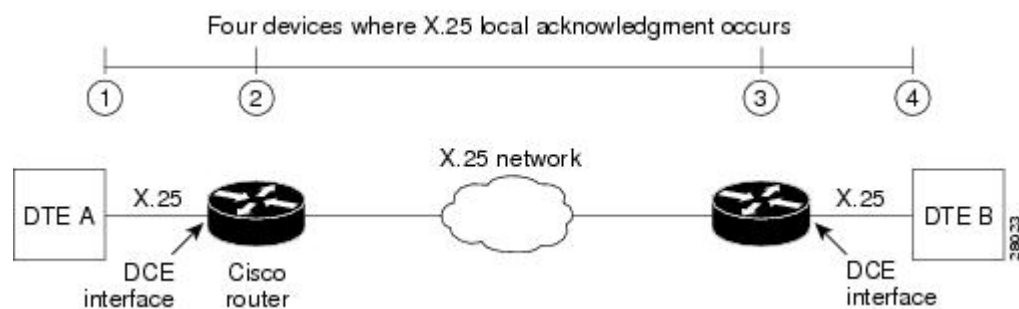

Flow Control Parameter Negotiation

Flow control is an X.25 optional user facility. When the **x25 subscribe flow-control** command is used, it permits flow control parameter negotiation of packet sizes and window sizes. This command can be altered to one of three states: default behavior (**no x25 subscribe flow-control**), facilities **always** included, or facilities **never** included (flow control parameter negotiation is not enabled). By default, these flow control parameter negotiation facilities are included in call setup (outgoing) packets only when their values differ from the default values.

When flow control parameter negotiation is enabled, the **x25 subscribe window-size** and **x25 subscribe packet-size** commands allow you to configure flow control restrictions by specifying window size and

packet size ranges for permitted and target values. A value that cannot be negotiated into the permitted range is treated as illegal, causing the call to fail. The router first attempts values within the target range, but allows values outside the target range to be considered as long as the range complies with procedures defined in the ITU-T *Recommendation X.25*. With this feature, the Cisco router allows different flow control value configurations and acceptable window and packet size formats for both DTE devices.

The ability to disable flow control parameter negotiation provides compatibility with equipment that does not support flow control parameter negotiation. Similarly, forcing flow control parameter negotiation provides compatibility with devices that require the flow control parameter negotiation facilities to be present in all calls.

To control packet transmission flow values on the interface, use one or more of the flow control commands--**x25 subscribe flow-control**, **x25 subscribe window-size**, or **x25 subscribe packet-size**--in interface configuration mode.

The flow control subscription commands may be applied to an X.25 interface, to an X.25 profile, or to a LAN interface on which the **cmns enable** command has been configured. For X.25 over TCP (XOT), the flow control parameter negotiation facilities are always included (the equivalent of **x25 subscribe flow-control always**).

Default Flow Control Values

Setting correct default flow control parameters of window size and packet size is essential for correct operation of the link because X.25 is a strongly flow controlled protocol. Mismatched default flow control values will cause X.25 local procedure errors, evidenced by Clear and Reset events.



Note

Because X.25 requires the DTE and DCE devices to have identical default maximum packet sizes and default window sizes, changes made to the window and packet sizes when the interface is up are held until X.25 restarts the packet service.

Default Window Sizes

X.25 networks have a default input and output window size (the default is 2) that is defined by your network administrator. You must set the Cisco IOS software default input and output window sizes to match those of the network. These defaults are the values that an SVC takes on if it is set up without explicitly negotiating its window sizes. Any PVC also uses these default values unless different values are configured.

Default Packet Sizes

X.25 networks have a default maximum input and output packet size (the default is 128) that is defined by your network administrator. You must set the Cisco IOS software default input and output maximum packet sizes to match those of the network. These defaults are the values that an SVC takes on if it is set up without explicit negotiation of its maximum packet sizes. Any PVC also uses these default values unless different values are configured.

To send a packet larger than the agreed-on X.25 packet size over an X.25 VC, the Cisco IOS software must break the packet into two or more X.25 packets with the M-bit ("more data" bit) set. The receiving device collects all packets in the M-bit sequence and reassembles them into the original packet.

It is possible to define default packet sizes that cannot be supported by the lower layer (see the LAPB N1 parameter). However, the router will negotiate lower maximum packet sizes for all SVCs so the agreed-on

sizes can be carried. The Cisco IOS software will also refuse a PVC configuration if the resulting maximum packet sizes cannot be supported by the lower layer.

Asymmetrical Flow Control

Asymmetrical flow control is supported by the permitted configuration of asymmetrical window and packet sizes. For data flow from a channel with a smaller packet size than its outbound channel, the switch may combine data packets, and for a channel with a larger packet size than its outbound channel, the switch will fragment the packets.

The figure below shows asymmetrical configuration of the Cisco router. DTE A (window size 3; packet size 128) and DTE B (window size 5; packet size 256) are able to communicate despite differing window and packet sizes.

Figure 2 Asymmetrical Window and Packet Sizes Between DTE A and DTE B



To use asymmetrical flow control effectively, use the **x25 subscribe flow-control never** command to disable flow control parameter negotiation, and use the **x25 routing acknowledge local** command to enable local acknowledgment.

X.25 Interface Parameters

Some X.25 applications have unusual or special needs. Several X.25 parameters are available to modify X.25 behavior for these applications.

- [X.25 Failover, page 9](#)
- [X.25 Level 3 Timers, page 10](#)
- [X.25 Addresses, page 10](#)
- [Default VC Protocol, page 11](#)
- [Disabling PLP Restarts, page 11](#)

X.25 Failover

Multiple routes can be configured in an X.25 routing table to allow one or more secondary or backup interfaces to be used when a preferred (primary) interface is not usable. Routes are examined in the order in which they appear in the X.25 routing table, and the first matching route is taken. However, since X.25 traffic is circuit-oriented, once a connection is established via the secondary interface, the connection remains active even after the primary interface returns to service. This situation is undesirable when the path via the secondary interface is slower or more expensive than the path via the primary interface.

X.25 Failover enables you to configure the secondary or backup interface to reset once the primary interface has come back up and remained operational for a specified amount of time, terminating any connections that are still using the secondary interface. Subsequent calls will then be forwarded over the preferred interface.

X.25 Failover supports Annex G (X.25 over Frame Relay), but it does not support XOT.

You can configure X.25 Failover on an X.25 interface or X.25 profile.

X.25 Level 3 Timers

The X.25 Level 3 event timers determine how long the Cisco IOS software waits for acknowledgment of control packets. You can set these timers independently. Only those timers that apply to the interface are configurable. (A DTE interface does not have the T1x timers, and a DCE interface does not have the T2x timers.)

X.25 Addresses

When you establish SVCs, X.25 uses addresses in the form defined by ITU-T *Recommendation X.121* (or simply an "X.121 address"). An X.121 address has from zero to 15 digits. Because of the importance of addressing to call setup, several interface addressing features are available for X.25.

The X.121 address of an X.25 interface is used when it is the source or destination of an X.25 call. The X.25 call setup procedure identifies both the calling (source) and the called (destination) X.121 addresses. When an interface is the source of a call, it encodes the interface X.121 address as the source address. An interface determines that it is the destination of a received call if the destination address matches the address of the interface.

Cisco IOS X.25 software can also route X.25 calls, which involves placing and accepting calls, but the router is neither the source nor the destination for these calls. Routing X.25 does not modify the source or destination addresses, thus preserving the addresses specified by the source host. Routed (switched) X.25 simply connects two logical X.25 channels to complete an X.25 VC. An X.25 VC, then, is a connection between two hosts (the source host and the destination host) that is switched between zero or more routed X.25 links.

The null X.121 address (the X.121 address that has zero digits) is a special case. The router acts as the destination host for any call it receives that has the null destination address.

A subaddress is an X.121 address that matches the digits defined for the X.121 address of the interface, but has one or more additional digits after the base address. X.25 acts as the destination host for an incoming PAD call with a destination that is a subaddress of the address of the interface; the trailing digits specify which line a PAD connection is requesting. This feature is described in the chapter "Configuring Protocol Translation and Virtual Asynchronous Devices" in the *Cisco IOS Terminal Services Configuration Guide*. Other calls that use a subaddress can be accepted if the trailing digit or digits are zeros; otherwise, the router will not act as the destination host of the call.

- [Interface Alias Address, page 10](#)
- [Suppressing or Replacing the Calling Address, page 10](#)
- [Suppressing the Called Address, page 11](#)

Interface Alias Address

You can supply alias X.121 addresses for an interface. Supplying alias addresses allows the interface to act as the destination host for calls having a destination address that is neither the address of the interface, an allowed subaddress of the interface, nor the null address.

Local processing (for example, IP encapsulation) can be performed only for incoming calls whose destination X.121 address matches the serial interface or alias of the interface.

Suppressing or Replacing the Calling Address

Some attachments require that no calling (source) address be presented in outgoing calls. This requirement is called *suppressing the calling address*. When attached to a PDN, X.25 may need to ensure that outgoing

calls use only the assigned X.121 address for the calling (source) address. Routed X.25 normally uses the original source address. Although individual X.25 route configurations can modify the source address, Cisco provides a simple command to force the use of the interface address in all calls sent; this requirement is called *replacing the calling address* .

Suppressing the Called Address

Some attachments require that no called (destination) address be presented in outgoing calls; this requirement is called *suppressing the called address* .

Default VC Protocol

The Call Request packet that sets up a VC can encode a field called the Call User Data (CUD) field. Typically the first few bytes of the CUD field identify which high-level protocol is carried by the VC. The router, when acting as a destination host, normally refuses a call if the CUD is absent or the protocol identification is not recognized. The PAD protocol, however, specifies that unidentified calls be treated as PAD connection requests. Other applications require that they be treated as IP encapsulation connection requests, in accordance with RFC 877, *A Standard for the Transmission of IP Datagrams over Public Data Networks* .

Disabling PLP Restarts

By default, a PLP restart is performed when the link level resets (for example, when LAPB reconnects). Although PLP restarts can be disabled for those few networks that do not allow restarts, we do not recommend disabling these restarts because doing so can cause anomalous packet layer behavior.



Caution

Very few networks require this feature. Cisco does not recommend that it be enabled except when you are attaching to a network that requires it.

X.25 Datagram Transport

- [Overview, page 11](#)
- [Point-to-Point and Multipoint Subinterfaces, page 12](#)
- [Mapping Protocol Addresses to X.121 Addresses, page 13](#)
- [Mapping Datagram Addresses to X.25 Hosts, page 14](#)
- [PAD Access, page 16](#)
- [Encapsulation PVC, page 16](#)
- [X.25 TCP IP Header Compression, page 16](#)
- [X.25 Bridging, page 17](#)

Overview

X.25 support is most commonly configured as a transport for datagrams across an X.25 network. Datagram transport (or encapsulation) is a cooperative effort between two hosts communicating across an X.25 network. You configure datagram transport by establishing a mapping on the encapsulating interface between the protocol address of the far host (for example, IP or DECnet) and its X.121 address. Because the call identifies the protocol that the VC will carry (by encoding a Protocol Identifier, or PID, in the first

few bytes of the CUD field), the terminating host can accept the call if it is configured to exchange the identified traffic with the source host.

The figure below illustrates two routers sending datagrams across an X.25 PDN.

Figure 3 *Transporting LAN Protocols Across an X.25 PDN*



Point-to-Point and Multipoint Subinterfaces

Subinterfaces are virtual interfaces that can be used to connect several networks to each other through a single physical interface. Subinterfaces are made available on Cisco routers because routing protocols, especially those using the split horizon principle, may need help to determine which hosts need a routing update. The split horizon principle, which allows routing updates to be distributed to other routed interfaces except the interface on which the routing update was received, works well in a LAN environment in which other routers reached by the interface have already received the routing update.

However, in a WAN environment using connection-oriented interfaces (like X.25 and Frame Relay), other routers reached by the same physical interface might not have received the routing update. Rather than forcing you to connect routers by separate physical interfaces, Cisco provides subinterfaces that are treated as separate interfaces. You can separate hosts into subinterfaces on a physical interface, X.25 is unaffected, and routing processes recognize each subinterface as a separate source of routing updates, so all subinterfaces are eligible to receive routing updates.

There are two types of subinterfaces: point-to-point and multipoint. Subinterfaces are implicitly multipoint unless configured as point-to-point.

A point-to-point subinterface is used to encapsulate one or more protocols between two hosts. An X.25 point-to-point subinterface will accept only a single encapsulation command (such as the **x25 map** or **x25 pvc** command) for a given protocol, so there can be only one destination for the protocol. (However, you can use multiple encapsulation commands, one for each protocol, or multiple protocols for one map or PVC.) All protocol traffic routed to a point-to-point subinterface is forwarded to the one destination host defined for the protocol. (Because only one destination is defined for the interface, the routing process need not consult the destination address in the datagrams.)

A multipoint subinterface is used to connect one or more hosts for a given protocol. There is no restriction on the number of encapsulation commands that can be configured on a multipoint subinterface. Because the hosts appear on the same subinterface, they are not relying on the router to distribute routing updates among them. When a routing process forwards a datagram to a multipoint subinterface, the X.25 encapsulation process must be able to map the destination address of the datagram to a configured encapsulation command. If the routing process cannot find a map for the datagram destination address, the encapsulation will fail.

**Note**

Because of the complex operations dependent on a subinterface and its type, the router will not allow a subinterface's type to be changed, nor can a subinterface with the same number be reestablished once it has been deleted. After a subinterface has been deleted, you must reload the Cisco IOS software (by using the **reload** command) to remove all internal references. However, you can easily reconstitute the deleted subinterface by using a different subinterface number.

For more information about configuring subinterfaces, refer to the chapter "Configuring Serial Interfaces" in the *Cisco IOS Interface Configuration Guide*.

When configuring IP routing over X.25, you might need to make adjustments to accommodate split horizon effects. Refer to the chapter "Configuring RIP" in the *Cisco IOS IP Configuration Guide* for details about possible split horizon conflicts. By default, split horizon is enabled for X.25 attachments.

Mapping Protocol Addresses to X.121 Addresses

- [Understanding Protocol Encapsulation for Single-Protocol and Multiprotocol VCs, page 13](#)
- [Understanding Protocol Identification, page 13](#)

Understanding Protocol Encapsulation for Single-Protocol and Multiprotocol VCs

Cisco has long supported encapsulation of a number of datagram protocols across X.25, using a standard method when available or a proprietary method when necessary. These traditional methods assign a protocol to each VC. If more than one protocol is carried between the router and a given host, each active protocol will have at least one VC dedicated to carrying its datagrams.

Cisco also supports a newer standard, RFC 1356, *Multiprotocol Interconnect on X.25 and ISDN in the Packet Mode*, which standardizes a method for encapsulating most datagram protocols over X.25. It also specifies how one VC can carry datagrams from more than one protocol.

The Cisco IOS software can be configured to use any of the available encapsulation methods with a particular host.

After you establish an encapsulation VC using any method, the Cisco IOS software sends and receives a datagram by simply fragmenting it into and reassembling it from an X.25 complete packet sequence. An X.25 complete packet sequence is one or more X.25 data packets that have the M-bit set in all but the last packet. A VC that can carry multiple protocols includes protocol identification data as well as the protocol data at the start of each complete packet sequence.

Understanding Protocol Identification

This section contains background material only.

The various methods and protocols used in X.25 SVC encapsulation are identified in a specific field of the call packet; this field is defined by X.25 to carry CUD. Only PVCs do not use CUD to identify their encapsulation (because PVCs do not use the X.25 call setup procedures).

The primary difference between the available Cisco and IETF encapsulation methods is the specific value used to identify a protocol. When any of the methods establishes a VC for carrying a single protocol, the protocol is identified in the call packet by the CUD.

The table below summarizes the values used in the CUD field to identify protocols.

Table 2 Protocol Identification in the CUD Field

Protocol	Cisco Protocol Identifier	IETF RFC 1356 Protocol Identifier
Apollo Domain	0xD4	0x80 (5-byte SNAP encoding) ¹
AppleTalk	0xD2	0x80 (5-byte SNAP encoding)
Banyan VINES	0xC0 00 80 C4 ²	0x80 (5-byte SNAP encoding)
Bridging	0xD5	Not implemented
ISO CLNS	0x81	0x81 ³
Compressed TCP	0xD8	0x00 (multiprotocol) ⁴
DECnet	0xD0	0x80 (5-byte SNAP encoding)
IP	0xCC	0xCC ⁵ or 0x80 (5-byte SNAP encoding)
Novell IPX	0xD3	0x80 (5-byte SNAP encoding)
PAD	0x01 00 00 00 ⁶	0x01 00 00 006
QLLC	0xC3	Not available
XNS	0xD1	0x80 (5-byte SNAP encoding)
Multiprotocol	Not available	0x00

Once a multiprotocol VC has been established, datagrams on the VC have protocol identification data before the actual protocol data; the protocol identification values are the same as those used by RFC 1356 in the CUD field for an individual protocol.

**Note**

IP datagrams can be identified with a 1-byte identification (0xCC) or a 6-byte identification (0x80 followed by the 5-byte SNAP encoding). The 1-byte encoding is used by default, although the SNAP encoding can be configured.

Mapping Datagram Addresses to X.25 Hosts

¹ SNAP encoding is defined according to the Assigned Numbers RFC; the Cisco implementation recognizes only the IETF organizational unique identifier (OUI) 0x00 00 00 followed by a 2-byte Ethernet protocol type.

² The use of 0xC0 00 80 C4 for Banyan VINES is defined by Banyan.

³ The use of 0x81 for CLNS is compatible with ISO/IEC 8473-3:1994.

⁴ Compressed TCP traffic has two types of datagrams, so IETF encapsulation requires a multiprotocol VC.

⁵ The use of 0xCC for IP is backward-compatible with RFC 877, IP encapsulation [RFC:08] RFC 877.

⁶ The use of 0x01 00 00 00 for PAD is defined by ITU-T Recommendation X.29.

Encapsulation is a cooperative process between the router and another X.25 host. Because X.25 hosts are reached with an X.121 address (an X.121 address has 0 to 15 decimal digits), the router must have a means to map protocols and addresses of the host to its X.121 address.

Each encapsulating X.25 interface must be configured with the relevant datagram parameters. For example, an interface that encapsulates IP typically will have an IP address.

A router set up for DDN or BFE service uses a dynamic mapping technique to convert between IP and X.121 addresses. These techniques have been designed specifically for attachment to the DDN network and to Blacker encryption equipment. Their design, restrictions, and operation make them work well for these specific applications, but not for other networks.

You must also establish the X.121 address of an encapsulating X.25 interface using the **x25 address** interface configuration command. This X.121 address is the address to which encapsulation calls are directed, and is also the source X.121 address used for originating an encapsulation call. It is used by the destination host to map the source host and protocol to the protocol address. An encapsulation VC must be mapped at both the source and destination host interfaces. A DDN or BFE interface will have an X.121 address generated from the interface IP address, which, for proper operation, should not be modified.

For each X.25 interface, you must explicitly map the protocols and addresses for each destination host to its X.121 address. If needed and the destination host has the capability, one host map can be configured to support several protocols; alternatively, you can define one map for each supported protocol.

To establish an X.25 map, use the **x25 map** command in interface configuration mode.

For example, if you are encapsulating IP over a given X.25 interface, you must define an IP address for the interface and, for each of the desired destination hosts, map the IP address of the host to its X.121 address.

Note

You can map an X.121 address to as many as nine protocol addresses, but each protocol can be mapped only once in the command line.

An individual host map can use keywords to specify the following protocols:

- **apollo** --Apollo Domain
- **appletalk** --AppleTalk
- **bridge** --Bridging
- **clns** --OSI Connectionless Network Service
- **compressedtcp** --TCP/IP header compression
- **decnet** --DECnet
- **ip** --IP
- **ipx** --Novell IPX
- **pad** --Packet assembler/disassembler
- **qllc** --IBM QLLC
- **vines** --Banyan VINES
- **xns** --XNS

Each mapped protocol, except bridging and CLNS, takes a datagram address. All bridged datagrams are either broadcast to all bridging destinations or sent to the X.121 address of a specific destination host, and CLNS uses the mapped X.121 address as the subnetwork point of attachment (SNPA), which is referenced by a **clns neighbor** command. The configured datagram protocols and their relevant addresses are mapped to the X.121 address of the destination host. All protocols that are supported for RFC 1356 operation can be specified in a single map. (Bridging and QLLC are not supported for RFC 1356 encapsulation.) If IP and TCP/IP header compression are both specified, the same IP address must be given for both protocols.

When setting up the address map, you can include options such as enabling broadcasts, specifying the number of VCs allowed and defining various user facility settings.

**Note**

Multiprotocol maps, especially those configured to carry broadcast traffic, can result in significantly larger traffic loads, requiring a larger hold queue, larger window sizes, or multiple VCs.

For specific information about how to establish a protocol to run over X.25, refer to the appropriate protocol chapters in the *Cisco IOS IP Configuration Guide*, *Cisco IOS AppleTalk and Novell IPX Configuration Guide*, and *Cisco IOS Apollo Domain, Banyan VINES, DECnet, ISO CLNS, and XNS Configuration Guide*.

You can simplify the configuration for the Open Shortest Path First (OSPF) protocol by adding the optional **broadcast** keyword. See the **x25 map** command description in the *Cisco IOS Wide-Area Networking Command Reference* for more information.

PAD Access

By default, PAD connection attempts are processed for session creation or protocol translation (subject to the configuration of those functions) from all hosts. You can configure outgoing PAD access using the optional features of the **x25 map pad** command without restricting incoming PAD connections to the configured hosts.

Encapsulation PVC

PVCs are the X.25 equivalent of leased lines; they are never disconnected. You need not configure an address map before defining a PVC; an encapsulation PVC implicitly defines a map.

To establish a PVC, use the **x25 pvc** command. The **x25 pvc** command uses the same protocol keywords as the **x25 map** command. See the section "[Mapping Datagram Addresses to X.25 Hosts, page 14](#)" earlier in this chapter for a list of protocol keywords. Encapsulation PVCs also use a subset of the options defined for the **x25 map** command.

The user may establish multiple, parallel PVCs that carry the same set of encapsulation traffic by specifying the identical mappings for each PVC. Additionally, the user can permit a mixture of SVCs and PVCs to carry the traffic set by using the **x25 map** command to specify an **nvc** count that exceeds the number of configured PVCs. The total number of VCs, of whatever type, can never exceed 8.

X.25 TCP IP Header Compression

Cisco supports RFC 1144 TCP/IP header compression (THC) on serial lines using HDLC and X.25 encapsulation. THC encapsulation is only slightly different from other encapsulation traffic, but the differences are worth noting. The implementation of compressed TCP over X.25 uses one VC to pass the compressed packets. Any IP traffic (including standard TCP) is separate from THC traffic; it is carried over separate IP encapsulation VCs or identified separately in a multiprotocol VC.

**Note**

If you specify both **ip** and **compressedtcp** in the same **x25 map compressedtcp** command, they must both specify the same IP address.

X.25 Bridging

Cisco IOS transparent bridging software supports bridging over X.25 VCs. Bridging is not supported for RFC 1356 operation. Bridge maps must include the **broadcast** option for correct operation.

Additional X.25 Datagram Transport Features

The Cisco IOS software allows you to configure additional X.25 datagram transport features, including various user facilities defined for X.25 call setup by using the options in the **x25 map** or **x25 pvc** encapsulation command (or by setting an interface default).

- [X.25 Payload Compression, page 17](#)
- [Establishing the Packet Acknowledgment Policy, page 17](#)
- [X.25 User Facilities, page 18](#)

X.25 Payload Compression

For increased efficiency on relatively slow networks, the Cisco IOS software supports X.25 payload compression of outgoing encapsulation traffic.

The following restrictions apply to X.25 payload compression:

- The compressed VC must connect two Cisco routers, because X.25 payload compression is not standardized.

The data packets conform to X.25 rules, so a compressed VC can be switched through standard X.25 equipment. However, only Cisco routers can compress and decompress the data.

- Only datagram traffic can be compressed, although all the encapsulation methods supported by Cisco routers are available (for example, an IETF multiprotocol VC can be compressed).

SVCs cannot be translated between compressed and uncompressed data, nor can PAD data be compressed.

- X.25 payload compression must be applied carefully.

Each compressed VC requires significant memory resources (for a dictionary of learned data patterns) and computation resources (every data packet received is decompressed and every data packet sent is compressed). Excessive use of compression can cause unacceptable overall performance.

- X.25 compression must be explicitly configured for a map command.

A received call that specifies compression will be rejected if the corresponding host map does not specify the **compress** option. An incoming call that does not specify compression can, however, be accepted by a map that specifies compression.

To enable payload compression over X.25, use the **x25 map** command. This command specifies that X.25 compression is to be used between the two hosts. Because each VC established for compressed traffic uses significant amounts of memory, compression should be used with careful consideration of its impact on the performance. The **compress** keyword may be specified for an encapsulation PVC.

Establishing the Packet Acknowledgment Policy

You can instruct the Cisco IOS software to send an acknowledgment packet when it has received a threshold of data packets it has not acknowledged, instead of waiting until its input window is full. A value of 1 sends an acknowledgment for each data packet received if it cannot be acknowledged in an outgoing

data packet. This approach improves line responsiveness at the expense of bandwidth. A value of 0 restores the default behavior of waiting until the input window is full.

X.25 User Facilities

X.25 software provides commands to support X.25 user facilities options (specified by the ITU-T *Recommendation X.25*) that allow you to use network features such as reverse charging, user identification, and flow control negotiation. You can choose to configure facilities on a per-map basis or on a per-interface basis. In the following table, the **x25 map** commands configure facilities on a per-map basis; the **x25 facility** commands specify the values set for all encapsulation calls originated by the interface. Routed calls are not affected by the facilities specified for the outgoing interface.

The **packetsize** and **window size** and options are supported for PVCs, although the options have a slightly different meaning on PVCs from what they mean on interfaces because PVCs do not use the call setup procedure. If the PVC does not use the interface defaults for the flow control parameters, these options must be used to specify the values. Not all networks will allow a PVC to be defined with arbitrary flow control values.

Additionally, the D-bit is supported, if negotiated. PVCs allow the D-bit procedure because there is no call setup to negotiate its use. Both restricted and unrestricted fast select are also supported and are transparently handled by the software. No configuration is required for use of the D-bit or fast select facilities.

X.25 Routing

The X.25 software implementation allows VCs to be routed from one X.25 interface to another and from one router to another. The routing behavior can be controlled with switching and XOT configuration commands, based on a locally built table.

X.25 encapsulation can share an X.25 serial interface with the X.25 switching support. Switching or forwarding of X.25 VCs can be done two ways:

- Incoming calls received from a local serial interface running X.25 can be forwarded to another local serial interface running X.25. This method is known as *local X.25 switching* because the router handles the complete path. It does not matter whether the interfaces are configured as DTE or DCE devices, because the software takes the appropriate actions.
- An incoming call can also be forwarded using the XOT service (previously *remote switching* or *tunneling*). Upon receipt of an incoming X.25 call, a TCP connection is established to the destination XOT host (for example, another Cisco router) that will, in turn, handle the call using its own criteria. All X.25 packets are sent and received over the reliable TCP data stream. Flow control is maintained end-to-end. It does not matter whether the interface is configured for DTE or DCE devices, because the software takes the appropriate actions.

Running X.25 over TCP/IP provides a number of benefits. The datagram containing the X.25 packet can be switched by other routers using their high-speed switching abilities. X.25 connections can be sent over networks running only the TCP/IP protocols. The TCP/IP protocol suite runs over many different networking technologies, including Ethernet, Token Ring, T1 serial, and FDDI. Thus X.25 data can be forwarded over these media to another router, where it can, for example, be switched to an X.25 interface.

When the connection is made locally, the switching configuration is used; when the connection is across a LAN, the XOT configuration is used. The basic function is the same for both types of connections, but different configuration commands are required for each type of connection.

The X.25 switching subsystem supports the following facilities and parameters:

- D-bit negotiation (data packets with the D-bit set are passed through transparently)

- Variable-length interrupt data (if not operating as a DDN or BFE interface)
- Flow control parameter negotiation:
 - Window size up to 7, or 127 for modulo 128 operation
 - Packet size up to 4096 (if the LAPB layers used are capable of handling the requested size)
- Basic CUG selection
- Throughput class negotiation
- Reverse charging and fast select

The handing of these facilities is described in the appendix "X.25 Facility Handling."

- [X.25 Route, page 19](#)

X.25 Route

An X.25 route table enables you to control which destination is selected for several applications. When an X.25 service receives a call that must be forwarded, the X.25 route table determines which X.25 service (X.25, CMNS, or XOT) and destination should be used. When a PAD call is originated by the router, either from a user request or from a protocol translation event, the route table similarly determines which X.25 service and destination should be used.

You create the X.25 route table and add route entries to it. You can optionally specify the order of the entries in the table, the criteria to match against the VC information, and whether to modify the destination or source addresses. Each entry must specify the disposition of the VC (that is, what is done with the VC). Each route can also specify XOT keepalive options.

The route table is used as follows:

- VC information is matched against selection criteria specified for each route.
- The table is scanned sequentially from the top.
- The first matching route determines how the VC is handled.
- Once a matching entry is found, the call addresses can be modified and the call disposed of (forwarded or cleared) as instructed by the entry.

Each application can define special conditions if a route will not be used or what occurs if no route matches. For instance, switched X.25 will skip a route if the disposition interface is down and clear a call if no route matches. X.25 PAD and PAD-related applications, such as protocol translation using X.25, will route the call to the default X.25 interface, which is the first X.25 interface configured.

To configure an X.25 route (thus adding the route to the X.25 routing table), use the **x25 route** command.

Additional X.25 Routing Features

- [X.25 Load Balancing, page 19](#)
- [XOT to Use Interface Default Flow Control Values, page 20](#)
- [Calling Address Interface-Based Insertion and Removal, page 21](#)

X.25 Load Balancing

X.25 load balancing was created to solve the problem that arises when the number of users accessing the same host causes an overload on Internet service provider (ISP) application resources.

In the past, in order to increase the number of users they could support, ISPs had to increase the number of X.25 lines to the host. To support a large number of VCs to a particular destination, they had to configure

more than one serial interface to that destination. When a serial interface is configured to support X.25, a fixed number of VCs is available for use. However, the X.25 allocation method for VCs across multiple serial lines filled one serial line to its VC capacity before utilizing the second line at all. As a result, the first serial line was frequently carrying its maximum data traffic before it ran out of VCs.

Using a facility called *hunt groups*, the X.25 Load Balancing feature causes a switch to view a pool of X.25 lines going to the same host as one address and assign VCs on an idle logical channel basis. With this feature, X.25 calls can be load-balanced among all configured outgoing interfaces to fully use and balance performance of all managed lines. X.25 load balancing allows two load-balancing distribution methods--rotary and vc-count--utilizing multiple serial lines.

The rotary method sends every call to the next available interface, regardless of line speed and the number of available VCs on that interface.

The vc-count method sends calls to the interface that has the largest number of available logical channels. This method ensures a good load balance when lines are of equal speed. If the line speeds are unequal, the vc-count method will favor the line with the higher speed. To distribute calls equally among interfaces regardless of line speed, configure each interface with the same number of VCs. In cases where interfaces have the same line speed, the call is sent to the interface that is defined earliest in the hunt group.

With the vc-count distribution method, if a hunt group does not contain an operational interface, the call is forwarded to the next route if one has been specified. An interface is considered unoperational if that interface is down or full. If a session is terminated on an interface within the hunt group, that interface now has more available VCs, and it will be chosen next.



Note

XOT cannot be used in hunt groups configured with the vc-count distribution method. XOT does not limit the number of calls that can be sent to a particular destination, so the method of selecting the hunt group member with the largest number of available VCs will not work. XOT can be used in hunt groups configured with the rotary distribution method.

Only one distribution method can be selected for each hunt group, although one interface can participate in one or more hunt groups. Reconfiguration of hunt groups does not affect functionality, but distribution methods are limited to rotary and vc-count only.

XOT to Use Interface Default Flow Control Values

When a connection is set up, the source and destination XOT implementations must cooperate to determine the flow control values that apply to the SVC. The source XOT ensures cooperation by encoding the X.25 flow control facilities (the window sizes and maximum packet sizes) in the X.25 Call packet; the XOT implementation of the far host can then correctly negotiate the flow control values at the destination interface and, if needed, indicate the final values in the X.25 Call Confirm packet.

When XOT receives a call that leaves one or both flow control values unspecified, it supplies the values. The values supplied are a window size of 2 packets and maximum packet size of 128 bytes; according to the standards, any SVC can be negotiated to use these values. Thus when XOT receives a call from an older XOT implementation, it can specify in the Call Confirm packet that these flow control values must revert to the lowest common denominator.

The older XOT implementations required that the source and destination XOT router use the same default flow control values on the two X.25 interfaces that connect the SVC. Consequently, connections with mismatched flow control values were created when this assumption was not true, which resulted in mysterious problems. In the Cisco IOS Release 12.2 XOT implementation, the practice of signalling the values used in the Call Confirm packet avoids these problems.

Occasionally the older XOT implementation will be connected to a piece of X.25 equipment that cannot handle modification of the flow control parameters in the Call Confirm packet. These configurations should

be upgraded to use a more recent version of XOT; when upgrade is not possible, the behavior of XOT causes a migration problem. In this situation, you may configure the Cisco IOS software to cause XOT to obtain unspecified flow control facility values from the default values of the destination interface.

Calling Address Interface-Based Insertion and Removal

This feature describes a modification to the **x25 route** command that allows interface-based insertion and removal of the X.121 address in the X.25 routing table.

This capability allows Cisco routers running X.25 to conform to the standard that specifies that X.25 DCE devices should not provide the X.25 calling address, but instead that it should be inserted by the X.25 DTE based on interface. This calling address insertion and removal feature was designed for all routers performing X.25 switching and requiring that an X.121 address be inserted or removed by the X.25 DTE based on the interface.

This feature does not support XOT to X.25 routing using the **input-interface** keyword introduced by the Calling Address Insertion and Removal feature.

DNS-Based X.25 Routing

- [Overview, page 21](#)
- [Address Resolution, page 22](#)
- [Mnemonic Resolution, page 23](#)

Overview

Managing a large TCP/IP network requires accurate and up-to-date maintenance of IP addresses and X.121 address mapping information on each router database in the network. Because these IP addresses are constantly being added and removed in the network, the routing table of every router needs to be updated, which is a time consuming and error-prone task. This process has also been a problem for mnemonics (an easy-to-remember alias name for an X.121 address).

X.25 has long operated over an IP network using XOT. However, large networks and financial legacy environments experienced problems with the amount of route configuration that needed to be done manually, as each router switching calls over TCP needed every destination configured. Every destination from the host router needed a static IP route statement, and for larger environments, these destinations could be as many as several thousand per router. Until the release of Domain Name System (DNS)-based X.25 routing, the only way to map X.121 addresses and IP addresses was on a one-to-one basis using the **x25 route x121address xot ipaddress** command.

The solution was to centralize route configurations that routers could then access for their connectivity needs. This centralization is the function of DNS-based X.25 routing, because the DNS server is a database of all domains and addresses on a network.

DNS-based X.25 routing scales well with networks that have multiple XOT routers, simplifies maintenance of routing table and creation of new routes, and reduces labor-intensive tasks and the possibility of human error during routing table maintenance. You must have DNS activated and X.25 configured for XOT to enable DNS-based X.25 routing.

DNS has the following three components:

- Domain name space or resource records--Define the specifications for a tree-structured domain name space.
- Name servers--Hold information about the domain tree structure.

- Resolvers--Receive a client request and return the desired information in a form compatible with a local hosts data formats.

You need to maintain only one route statement in the host router to connect it to the DNS. When DNS is used, the following rules apply:

- You must use Cisco IOS name server configuration commands.
- X.28 mnemonic restrictions apply (for example, not using -, ., **P**, or **D** in the mnemonic).
- You cannot specify any **x25 route** command options on the DNS. These options must be configured within the **x25 route** command itself.
- Names must consist of printable characters.
- No embedded white space is permitted.
- Periods must separate subdomains.
- Names are case sensitive.
- You must append any domain configured for the router to the user-specified name format.
- The total length of the name must not exceed 255 characters.

For more information on configuring the DNS, see the chapter "Configuring the DNS Service" in the *Cisco DNS/DHCP Manager Administrator's Guide*.



Note

This feature should not be used in the public Internet. It should be used only for private network implementations because in the Internet world the DNS has conventions for names and addresses with which DNS-based X.25 routing does not comply.

Address Resolution

With DNS-based X.25 routing, managing the X.121-to-IP addressing correlation and the mnemonic-to-X.121 addressing correlation is easy. Instead of supplying the router multiple route statements to all destinations, it may be enough to use a single wildcard route statement that covers all addresses in the DNS.

The **x25 route disposition xot** command option has been modified to include the **dns pattern** argument after the **xot** keyword, where *pattern* is a rewrite element that works in the same way that address substitution utilities work (see the *Cisco IOS Wide-Area Networking Command Reference* for further details).

The wildcard **^.*** characters and **\0** pattern of the modified **x25 route ^.* xot dns \0** command give the command more universality and effectiveness and make DNS-based X.25 routing simple and easy to use. These characters and pattern already exist and are explained in detail under the **x25 route** command in the *Cisco IOS Wide-Area Networking Command Reference*. This command functions only if the DNS route table mapping has been configured in a method recognized and understood by X.25 and the DNS server.

The following example is a setup from a DNS route table showing which X.121 address relates to which IP address:

```
222 IN      A      172.18.79.60
444 IN      A      10.1.1.3
555 IN      A      10.1.1.2 10.1.2.2 10.1.3.2 10.1.4.2 10.1.5.7 10.1.6.3
```

The command line **x25 route 444 xot dns \0** shown in the DNS-based X.25 routing configuration example is what extracts the IP address from the DNS. The **\0** pattern replaces itself with 444. The 444 is then used as the index into the DNS route table to generate the IP address 10.1.1.3. Other characters can be combined with the pattern; for example, **A-\0**. In the DNS database, the index would appear as A-444.

As the example in the figure below shows, a call sent by the router goes to the DNS. The DNS checks its route table and identifies the X.121 address 444 and its related IP address 10.1.1.3. The DNS returns the IP

address to the host router, which then creates a route statement and forwards the data to the IP address of the destination router (10.1.1.3).

If the DNS-based X.25 routing configuration example included the command `x25 route 555 xot dns \0`, then a call to the X.121 address 555 would also go to the DNS. Since multiple IP addresses have been configured in the domain name space records, all of the IP addresses for that domain name would be returned to the router. Each address would be tried in sequence, just as if the X.25 routing configuration had been `x25 route 555 xot 10.1.1.2 10.1.2.2 10.1.3.2 10.1.4.2 10.1.5.7 10.1.6.3`. The router will accept up to 6 IP addresses from DNS for the domain name. If there are more than six, there will be an error message, and the list will be truncated to the first six received.

Figure 4 DNS-Based X.25 Routing Using XOT over an IP Cloud

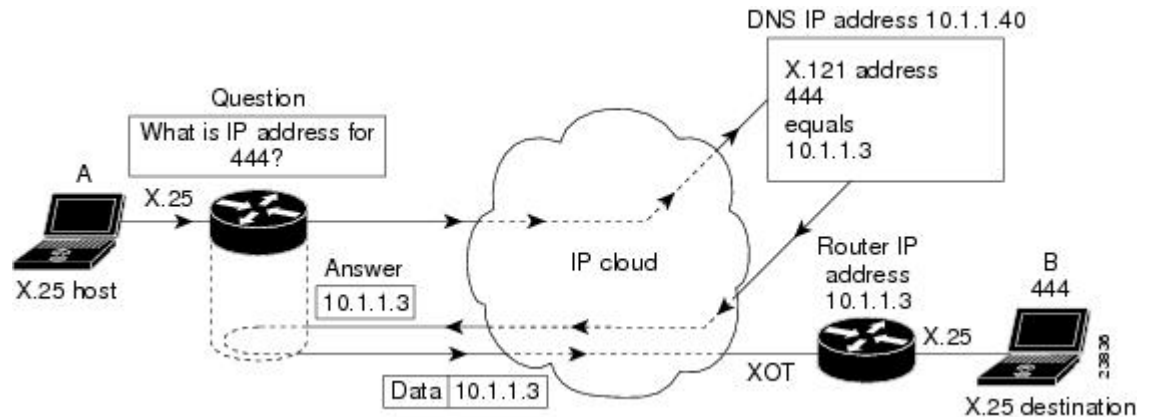

Mnemonic Resolution

DNS-based X.25 routing can be used for mnemonic resolution with or without use of XOT routing. For more information on mnemonic addressing, refer to the chapter "Configuring the Cisco PAD Facility for X.25 Connections" chapter in the *Cisco IOS Terminal Services Configuration Guide*.

When mnemonics are used with XOT, the same communication with the DNS occurs, except that the router needs to contact the DNS twice--first to get the X.121 address using the mnemonic, and then to get the IP address using the X.121 address. However, there is no substantial performance issue because the process happens very quickly.

The following example is a setup from the DNS route table showing a mnemonic and its related X.121 address ("destination_host" represents 222). The **X25** keyword ensures that this line will be recognized by DNS-based X.25 routing in the DNS server.

```
destination_host IN      X25      222
```

Using X.28 to retrieve this address, you would enter the following commands:

```
Router# x28
*destination_host
Translating "destination_host"...domain server (10.1.1.40)
```

Notice the output line requesting mnemonic resolution from the DNS server with IP address 10.1.1.40.

If you were using PAD, you would need to enter only the mnemonic name, as in the following example:

```
Router# pad destination_host
```

**Caution**

You must remove any permanent entry for X.25 located in the host table of the router that has been duplicated in the DNS route table (as part of the enabling process for DNS-based X.25 routing). Otherwise, DNS-based X.25 routing will be overridden by the host table entries of the router.

To configure DNS-based X.25 routing, use the following command in global configuration mode. This task assumes that you already have XOT and DNS configured and enabled and that the route table in the DNS server has been correctly organized.

X.25 over Frame Relay (Annex G)

Annex G (X.25 over Frame Relay) facilitates the migration of traffic from an X.25 backbone to a Frame Relay backbone by permitting encapsulation of X.25 traffic within a Frame Relay connection. With Annex G, transporting X.25 over Frame Relay has been simplified by allowing direct and transparent X.25 encapsulation over a Frame Relay network. Annex G is supported only on Frame Relay main interfaces (not subinterfaces) and over Frame Relay PVCs. However, X.25 PVC connections are not supported, but only X.25 SVC connections.

X.25 profiles make Annex G easy to configure for both X.25 and LAPB because they consist of bundled X.25 and LAPB commands. Once created and named, X.25 profiles can be simultaneously associated with more than one DLCI connection, using just the profile name. This process means that you need not enter the same X.25 or LAPB commands for each DLCI you are configuring. Multiple Annex G DLCIs can use the same X.25 profile, but the DLCIs can be configured for only one Frame Relay service at a time. The creation of X.25 profiles allows the specification of X.25 and LAPB configurations without the need to allocate hardware interface data block (IDB) information. X.25 profiles do not support IP encapsulation.

Annex G provides multiple logical X.25 SVCs per Annex G link, and modulo 8 and 128 are supported. X.25 Layers 2 and 3 are transparently supported over Annex G. LAPB treats the Frame Relay network like an X.25 network link and passes all of the data and control messages over the Frame Relay network. Before enabling Annex G connections you must establish a Frame Relay connection.

CMNS Routing

CMNS provides a mechanism through which X.25 services can be extended to nonserial media through the use of packet-level X.25 over frame-level logical link control (LLC2). For information about configuring LLC2 parameters, refer to the chapter "Configuring SDLC and LLC2 Parameters" in the *Cisco IOS Bridging and IBM Networking Configuration Guide*.

The Cisco CMNS implementation permits most X.25 services to be extended across a LAN, although datagram encapsulation and QLLC operations are not available. For example, a DTE host and a Sun workstation can be interconnected via the router's LAN interfaces *and* to a remote OSI-based DTE through a WAN interface to an X.25 packet-switched network (PSN).

Priority Queueing or Custom Queueing for X.25

Two types of output queueing are available for X.25:

- Priority queueing--Classifies packets on the basis of certain criteria and then assigns the packets to one of four output queues, with high, medium, normal, or low priority.
- Custom queueing--Classifies packets, assigns them to one of 16 output queues, and controls the percentage of available bandwidth for an interface that is used for a queue.

Output queueing for X.25 interfaces differs subtly from its use with other protocols because X.25 is a strongly flow-controlled protocol. Each X.25 VC has an authorized number of packets it can send before it must suspend transmission to await acknowledgment of one or more of the packets that were sent.

Queue processing is also subject to a VC's ability to send data; a high priority packet on a VC that cannot send data will not stop other packets from being sent if they are queued for a VC that can send data. In addition, a datagram that is being fragmented and sent may have its priority artificially promoted if higher-priority traffic is blocked by the fragmentation operation.

Both priority queueing and custom queueing can be defined, but only one method can be active on a given interface.

**Note**

Connection-oriented VCs (for example, QLLC, PAD, and switched X.25) will use the default queue of the interface. To maintain the correct order, all connection-oriented VCs use a single output queue for sending data.

X.25 Closed User Groups

- [Closed User Group, page 25](#)
- [Understanding CUG Configuration, page 27](#)
- [Point of Presence, page 28](#)
- [CUG Membership Selection, page 28](#)
- [CUG Service Access and Properties, page 29](#)
- [POP with No CUG Access, page 29](#)
- [POP with Access Restricted to One CUG, page 30](#)
- [POP with Multiple CUGs and No Public Access, page 30](#)
- [POP with Multiple CUGs and Public Access, page 30](#)
- [CUG Selection Facility Suppression, page 30](#)

Closed User Group

A closed user group (CUG) is a collection of DTE devices for which the network controls access between two members and between a member and a nonmember. An X.25 network can support up to 10,000 CUGs (numbered from 0 to 9999), each of which can have any number of member DTE devices. An individual DTE becomes a member of a specific network CUG by subscription. The subscription data includes the local number the DTE will use to identify the network CUG (which may or may not be the same as the network number, as determined by network administration and the requirements of the DTE device), and any restriction that prohibits the DTE from placing a call within the CUG or, conversely, prohibits the network from presenting a call within the CUG to the DTE device.

The X.25 DCE interfaces of the router can be configured to perform the standard CUG access controls normally associated with a direct attachment to an X.25 network POP. The DCE interface of the router acts as the boundary between the DTE and the network, and CUG use ensures that only those incoming and outgoing SVCs consistent with the configured CUG subscriptions are permitted. X.25 CUG configuration commands on the router are specified at every POP, and CUG security decisions are made solely from those commands. However, CUG service is not supported on XOT connections.

CUG security depends on CUG decisions made by the two POPs used to connect an SVC through the network, so CUG security depends on the collective configuration of all POPs that define the network

boundary. The standalone interface configuration determines if the POP will permit user access for a given incoming or outgoing call within the authorized CUG.

CUGs are a network service designed to allow various network subscribers (DTE devices) to be segregated into private subnetworks with limited incoming or outgoing access. This means that a DTE must obtain membership from its network service (POP) for the set of CUGs it needs access to. A DTE may subscribe to zero, one, or several CUGs at the same time. A DTE that does not require CUG membership for access is considered to be in the open part of the network. Each CUG typically permits subscribing users to connect to each other, but precludes connections with nonsubscribing DTE devices.

However, CUG behavior is highly configurable. For instance, a CUG configuration may subscribe a DTE to a given CUG, but bar it from originating calls within the CUG or, conversely, bar it from receiving calls identified as being within the CUG. CUG configuration can also selectively permit the DTE to originate calls to a DTE on the open network, or permit the DTE to receive calls from a DTE on the open network.

CUG access control is first applied when the originating DTE places a call to the POP, and again when the POP of the destination DTE device receives the call for presentation. Changes to the POP CUG subscriptions will not affect any SVCs that have already been established.

When a DTE belongs to more than one CUG, it must specify its preferential CUG, unless a call is specifically aimed at devices outside the CUG network. However, the number of CUGs to which a DTE can belong depends on the size of the network. Unsubscribing from one CUG or the overall CUG service will not result in the termination of the SVC connections.

CUG behavior is a cooperative process between two network devices. The DCE offers this service to the connecting subscribers via the DTE device. There is no global database regarding CUG membership; therefore, the Cisco router uses information configured for the various X.25 devices and the encoded CUG information in the outgoing and incoming packets.

X.25 CUGs are used for additional X.25 access protection and security. In a setup where DTE devices are attached to a PDN, you can derive a private subnetwork by subscribing your DTE devices to a set of CUGs, which allows closer control of your DTE devices, such as permitting or restricting which DTE can talk to other DTE devices and for what particular purpose. For example, a distinct CUG can be defined to handle each of the different modes of connectivity, such as the following:

- Datagram encapsulation operation among all company sites
- PAD services for customers seeking public information
- PAD services for system administration internal access to consoles
- QLLC access restricted to the company financial centers

One site could have different CUG subscriptions, depending on connectivity requirements. These sites could all have restrictions regarding which other company devices can be reached (within a CUG), whether a device is permitted to call the open network for a given function, and whether a public terminal can access the device for a given function.

By default, no CUG behavior is implemented. Therefore, in order to observe CUG restrictions, all users attached to the network must be subscribed to CUG behavior (CUG membership) even if they are not subscribed to a specific CUG.

The figure below shows two CUGs (CUG 1 and CUG 2). DTE devices A, B, and C are members of CUG 1. They can initiate and receive calls only from the other members of CUG 1. They are therefore members of a private subnet with no access to other DTE devices. DTE A is also a member of CUG 2 with DTE D, but DTE D cannot send calls to or receive calls from DTE B or DTE C. The router checks each received call to determine if it is intended for their CUG. If not, the router rejects the call.

You can subscribe to multiple CUGs per interface, but each CUG that is permitted must be specifically configured. All CUGs are sorted by their local identifier. The main limitation to the number of CUGs configured is the amount of nonvolatile memory to store the configuration. Having subscribed to a CUG,

the DTE indicates which CUG is being called. If the DTE does not indicate a CUG, its DCE determines which CUG is used and if the call should be allowed.

**Note**

CUG service is implemented at the DCE interface, which means that it specifies a network function. For a summary of DCE operations, refer to *ITU-T 1996 Recommendation X.301* tables 7-6 and 7-8.

Figure 5 DTE Devices A, B, C, and D Connecting to CUGs 1 and 2 over a PDN

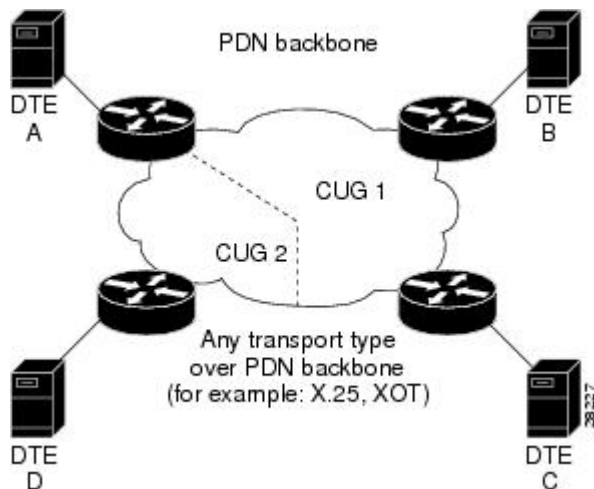

Understanding CUG Configuration

Answering the following questions will help you set up your CUG service and CUGs:

- Do you want to permit incoming public access to the DTE device?

If so, configure the **x25 subscribe cug-service incoming-access** command on the DCE so that the CUG service from the open network allows incoming calls to the DTE device.

- Do you want to permit outgoing public access for the DTE device?

If so, configure the **x25 subscribe cug-service outgoing-access** command on the DCE so that the CUG service allows public outgoing calls from the DTE to the open network.

- Will the CUG users require restricted access to the PDN?

If so, configure the **x25 subscribe local-cug** command for mapping the local CUG to the network CUG for the same CUG entity. To obtain full access to the PDN, the CUG service will need to be subscribed to by both incoming and outgoing access.

If you want a secure CUG with no access to the PDN, subscribe the CUG to no incoming or outgoing access, and configure it to communicate only with other attachments within CUGs that it has defined.

After establishing that you want PDN CUG access, you must then answer the following questions:

- ◦ Can the user place calls within the CUG?

The default is set for users to be able to place calls. If you do not want this setting, use the **no-outgoing** keyword.

- ◦ Can the user receive calls within the CUG?

The default is set for users to be able to receive calls. If you do not want this setting, use the **no-incoming** keyword.

- ◦ Do you want a subscribed CUG to be assumed when a CUG member places a call without specifying a CUG?

If so, use the **preferential** keyword.

Point of Presence

X.25 is not a POP by default, and POP behavior does not automatically enforce CUG security. Within PDNs, all devices are connected by POPs, which are open entry points into a network and, as such, pose a potential security risk.

When you enable X.25 CUG service, you are configuring your network like a PDN, and so for every POP with attachments in the network you must configure CUG security. CUG security is particularly important on those POPs that do not subscribe to CUGs, because they could act as a "back door" into your CUGs.



Note

If you do not configure CUG security on your network POPs, you are creating a security risk for your network. Configuration must be done manually for every POP in your network.

CUG Membership Selection

CUG membership selection occurs from the calling DTE in an outgoing (call request) packet to specify the CUG membership selected for the call. CUG membership selection is requested or received by a DTE only after the DTE has subscribed to one or more of the following facilities:

- Relevant CUG service
- Outgoing access CUG, which allows the source DTE to identify the CUG within which it is placing the call
- Incoming access CUG, which allows the destination DTE to identify the CUG to which both DTE devices belong

Preferential CUGs

A DTE that subscribes to more than one CUG (and permits neither incoming nor outgoing access from or to the open network) must designate a preferential CUG. Its use is assumed when no CUG selection is enabled in the outgoing call (call request) or incoming call. Using a preferential CUG achieves a higher level of security. Preferential CUG designation is for DTE devices meant to operate without requiring a CUG selection facility in every outgoing call, or for DTE devices not capable of encoding a CUG selection.

Preferential CUG designation options are as follows:

- If no preferential CUG has been designated and a CUG member presents a call without specifying a receiving CUG, the call will be rejected, unless incoming access from the open network is configured.
- If a preferential CUG has been designated and the user presents a call without specifying a CUG, the call will be directed to the preferential CUG.
- If outgoing access is permitted on your CUG and you present an outgoing call without designating a preferential CUG, then your CUG assumes the call is meant either for the open network or for the preferential CUG.
- A single CUG specified at a DCE interface is treated as the preferential CUG.

Incoming and Outgoing Access CUGs

CUG service with incoming access allows you to receive incoming calls from the open part of the network and from DTE devices belonging to other outgoing access CUGs. If the DTE does not subscribe to incoming access, any incoming call without the CUG membership selection facility will not be accepted.

A CUG with outgoing access allows you to make outgoing calls to the open part of the network and to DTE devices with incoming access capability. Subscribing to the outgoing access CUG allows a DTE to belong to one or more CUGs and to originate calls to DTE devices in the open part of the network (DTE devices not belonging to any CUGs) and to DTE devices belonging to incoming access CUGs. If the DTE has not subscribed to outgoing access, the outgoing packets must contain a valid CUG membership selection facility. If a CUG membership selection facility is not present, the local DCE defaults to the preferential CUG, or rejects the call if a preferential CUG is not specified.

Incoming and Outgoing Calls Barred Within a CUG

When a DTE wishes to initiate only outgoing calls, it specifies "incoming calls barred." With this CUG option subscribed to, a subscriber DTE is permitted only to originate calls and not to receive calls within the CUG. The DCE will clear an incoming call before it reaches the DTE.

If a DTE subscribes to the "outgoing calls barred" option, it is permitted to receive calls but not to originate calls within the CUG. An attempted outgoing call will be cleared by the DCE, which in turn will notify the DTE of its actions.

CUG Service Access and Properties



Note

If you do not want to enable the **x25 subscribe cug-service** command, you will be subscribed to CUG service automatically the first time you subscribe to a CUG (using the **x25 subscribe local-cug** command), with CUG service default settings of no incoming and no outgoing access.

You must establish X.25 DCE encapsulation and X.25 CUG service on the interface to enable this feature. Within the **x25 subscribe cug-service** command, establish the type of CUG public access (incoming or outgoing) you want. If you do not enter this command, the default will be enabled.

To set up the individual CUGs, use the **x25 subscribe local-cug** command to specify each local CUG and map it to a network CUG, setting the access properties of the local CUG--no-incoming, no-outgoing, preferential, all, or none--at the same time.

POP with No CUG Access



Caution

This configuration is critical to enforcing full CUG security on your network. You must conduct this configuration on every POP in your network. If you do not configure this for all POPs in your network, you will not have a secure network, and a security breach could occur.

With the POP configuration of no individual CUG subscriptions, the POP is a member of the open network. Even though it does not have a CUG attached, you must configure CUG security on it to ensure that the rest of your network remains secure. The POP has CUG incoming access and outgoing access permitted--the least restrictive setting. The POP will allow calls that do not require CUG authorization to and from the open network, but it will refuse any CUG-specified calls because the POP does not belong to a CUG. A call from an intranetwork connection with no CUG selected is permitted as incoming access from the open network, but a call that requires CUG access will be refused.

POP with Access Restricted to One CUG

In the POP configuration with one CUG subscribed, it is important to have no public access permitted on it. You do this by configuring the default setting (no incoming and no outgoing access) for the **x25 subscribe cug-service** command. When an outgoing call not specifying a CUG is made, the POP assumes the call to be for its one subscribed CUG. An incoming call that does not specify that CUG is rejected. This single CUG configuration assumes the CUG to be the preferential CUG.

POP with Multiple CUGs and No Public Access

With the POP configuration of multiple CUGs and no public access permitted, the only difference from the POP configuration with one subscribed CUG is that one of the CUGs must be chosen as preferential. If you do not specify a preferential CUG, no calls can be made or accepted. Notice the omission of the keywords from the **x25 subscribe cug-service** command. This omission enables the default settings of no incoming and no outgoing access.

POP with Multiple CUGs and Public Access

The least restrictive POP configuration is a POP configured to allow public access to members of several CUG and to originate and receive calls from the open network (that is, to or from users that do not subscribe to one of the CUGs to which this POP subscribes). Configuring the POP with multiple CUGs and public access is achieved using the **x25 subscribe cug-service** command with the addition of the keywords **incoming-access** and **outgoing-access** to allow calls to be made and received to and from outside hosts not in the specified CUG network.

To set up the individual CUGs, use the **x25 subscribe local-cug** command to specify each local CUG and map it to a network CUG, setting the access properties of the local CUG--no-incoming, no-outgoing, preferential, all, or none--at the same time.

An outgoing call may select any of the local CUGs or not. When no CUG is selected, it is assumed that the call is intended for the open network. The call will be refused if it specifies a local CUG different from the one to which the POP is subscribed. An incoming call may or may not select related network CUGs. If no CUG is selected, the call is accepted as coming from the open network. A call that requires access to a different CUG will be refused.

CUG Selection Facility Suppression

A CUG selection facility is a specific encoding element that can be presented in a call request or an incoming call. A CUG selection facility in a call request allows the source DTE to identify the CUG within which it is placing the call. A CUG selection facility in an incoming call allows the destination DTE to identify the CUG to which both DTEs belong.

You can configure an X.25 DCE interface or X.25 profile with a DCE station type to selectively remove the CUG selection facility before presenting an incoming call packet to a subscribed DTE. The CUG selection facility can be removed from incoming call packets destined for the preferential CUG only or for all CUGs. You can also remove the selection facility from a CUG with outgoing access (CUG/OA). The CUG selection facility suppression mechanism does not distinguish between CUGs and CUG/OAs.



Note

The CUG Selection Facility Suppress Option feature will not in any way compromise CUG security.

CUG selection facility suppression is supported by X.25 over Frame Relay (Annex G). If Annex G is being used, you must configure CUG selection facility suppression in an X.25 profile.

DDN or BFE X.25

- [DDN, page 31](#)
- [Understanding DDN X.25 Dynamic Mapping, page 31](#)
- [IP Precedence Handling, page 32](#)
- [Blacker Front End X.25, page 32](#)

DDN

The Defense Data Network (DDN) X.25 protocol has two versions: Basic Service and Standard Service. Cisco System's X.25 implementation supports only the Standard Service which also includes Blacker Front End (BFE).

DDN X.25 Standard Service requires that the X.25 data packets carry IP datagrams. The DDN packet switching nodes (PSNs) can extract the IP datagram from within the X.25 packet and pass data to another Standard Service host.

The DDN X.25 Standard is the required protocol for use with DDN PSNs. The Defense Communications Agency (DCA) has certified Cisco Systems' DDN X.25 Standard implementation for attachment to the Defense Data Network. As part of the certification, Cisco IOS software is required to provide a scheme for dynamically mapping Internet addresses to X.121 addresses.

Understanding DDN X.25 Dynamic Mapping

The DDN X.25 standard implementation includes a scheme for dynamically mapping all classes of IP addresses to X.121 addresses without a table. This scheme requires that the IP and X.121 addresses conform to the formats shown in the figures below. These formats segment the IP addresses into network (N), host (H), logical address (L), and PSN (P) portions. For the BFE encapsulation, the IP address is segmented into Port (P), Domain (D), and BFE ID number (B). The DDN algorithm requires that the host value be less than 64.

Figure 6 DDN IP Address Conventions

Class A:	Net.Host.LH.PSN → 0000 0 PPPHH00
Bits:	8 8 8 8
Class B:	Net.Net.Host.PSN → 0000 0 PPPHH00
Bits:	8 8 8 8
Class C:	Net.Net.Net.Host.PSN → 0000 0 PPPHH00
Bits:	8 8 8 4 4

Figure 7 BFE IP Address Conventions

BFE Class A :	Net.unused.Port.Domain.BFE → 0000 0 PDDDBBB
Bits:	8 1 3 10 10

The DDN conversion scheme uses the host and PSN portions of an IP address to create the corresponding X.121 address. The DDN conversion mechanism is limited to Class A IP addresses; however, the Cisco

IOS software can convert Class B and Class C addresses as well. As indicated, this method uses the last two octets of a Class B address as the host and PSN identifiers, and the upper and lower four bits in the last octet of a Class C address as the host and PSN identifiers, respectively. The BFE conversion scheme requires a Class A IP address.

The DDN conversion scheme uses a physical address mapping if the host identifier is numerically less than 64. (This limit derives from the fact that a PSN cannot support more than 64 nodes.) If the host identifier is numerically larger than 64, the resulting X.121 address is called a *logical address*. The DDN does not use logical addresses.

The format of physical DDN X.25/X.121 addresses is ZZZZFIIIHHZZ(SS). Each character represents a digit, described as follows:

- ZZZZ represents four zeros.
- F is zero to indicate a physical address.
- III represents the PSN octet from the IP address padded with leading zeros.
- HH is the host octet from the IP address padded with leading zeros.
- ZZ represents two zeros.
- (SS) represents the optional and unused subaddress.

The physical and logical mappings of the DDN conversion scheme always generate a 12-digit X.121 address. Subaddresses are optional; when added to this scheme, the result is a 14-digit X.121 address. The DDN does not use subaddressing.

Packets using routing and other protocols that require broadcast support can successfully traverse X.25 networks, including the DDN. This traversal requires the use of network protocol-to-X.121 maps, because the router must know explicitly where to deliver broadcast datagrams. (X.25 does not support broadcasts.) You can mark network protocol-to-X.121 map entries to accept broadcast packets; the router then sends broadcast packets to hosts with marked entries. For DDN or BFE operation, the router generates the interface X.121 addresses from the interface IP address using the DDN or BFE mapping technique.

IP Precedence Handling

Using Standard Service, the DDN can be configured to provide separate service for datagrams with high precedence values. When IP precedence handling is enabled, the router uses a separate X.25 SVC to handle each of four precedence classes of IP traffic--routine, priority, immediate, and other. An IP datagram is transmitted only across the SVC that is configured with the appropriate precedence.

By default, the DDN X.25 software opens one VC for all types of service values. Verify that your host does not send nonstandard data in the TOS field. Nonstandard data can cause multiple, wasteful VCs to be created.

Blacker Front End X.25

For environments that require a high level of security, the Cisco IOS software supports attachment to Defense Data Network (DDN) Blacker Front End (BFE) equipment. BFE encapsulation operates to map between Class A IP addresses and the X.121 addresses expected by the BFE encryption device.

X.25 Remote Failure Detection

X.25 remote failure detection is important because after a primary link failure, the router can establish a secondary link and continue sending data. The router detects a call failure and uses a secondary route to send subsequent packets to the remote destination, at the same time making periodic attempts to reconnect

to its primary link. The number of these attempts and the interval between such attempts is controlled using the **x25 retry** command. The failed link is marked up again when any of the following occurs:

- An attempt to reestablish the link via the retry mechanism is successful.
- An incoming call is received on the subinterface.
- The X.25 packet layer on the interface is restarted.

X.25 remote failure detection needs to be manually configured on each intended subinterface. However, because it is a per-destination configuration rather than a per-user configuration, you need it enabled only on the subinterface requiring the retry option--typically your primary interface. This feature is not automatically enabled and only responds to failed outgoing call attempts. The feature applies only to point-to-point subinterfaces and works only on SVCs. It is not necessary if you are running IP routing, because IP routing already implements alternate routing. This feature is targeted at environments that have static IP routing across an X.25 network, where these static IP routes currently need to be manually added to the route tables.

The **x25 retry** command is activated by a call failure notification. Retry occurs only with calls initiated on a subinterface configured with the **x25 retry** command. This command works only when no VCs are up. When reconnection occurs, traffic begins to reuse the primary interface. This resetting of the line protocol to up is the last activity that the **x25 retry** command conducts. Issuing the **clear x25** command on the remote failure detection configured interface, or receiving a call during retry, will disable the **x25 retry** and the subinterface will be marked "up." An incoming call can be conducted in a way similar to how the **ping** command is used to check connectivity (by definition, a successful incoming call indicates that connectivity is functioning). Also, if the router reaches its retry attempts limit, the **x25 retry** command will discontinue and the subinterface will remain down.

X.25 remote failure detection is designed to work with any network layer routed protocol. However, the feature depends on the ability of the protocol to handle more than one static route to the same destination at the same time. Currently, only IP can accomplish this multistatic route handling.

Alternatively, X.25 remote failure detection can be used to activate a backup link should the subinterface configured for retry be marked down via the retry mechanism. See the [X.25 Remote Failure Detection and the Backup Interface, page 67](#) configuration tasks for further details.

The benefits of this feature are network cost savings because IP routing updates (requiring dynamic but costly network connectivity) are not necessary; improved responsiveness and versatility of X.25 primary and alternate links; and more robust networking options for data transmission.

The figure below shows how X.25 remote failure detection works:

- 1 The data cannot reach its destination using its primary route.
- 2 A call failure notification is sent to the transmitting router.

- The **x25 retry** command is activated, and IP then activates the preassigned secondary route in its route table and begins sending data. The **x25 retry** command also shuts down subinterface 1.1 and begins its retry attempts on this link.

Figure 8 X.25 Remote Failure Detection in Action over an X.25 Cloud

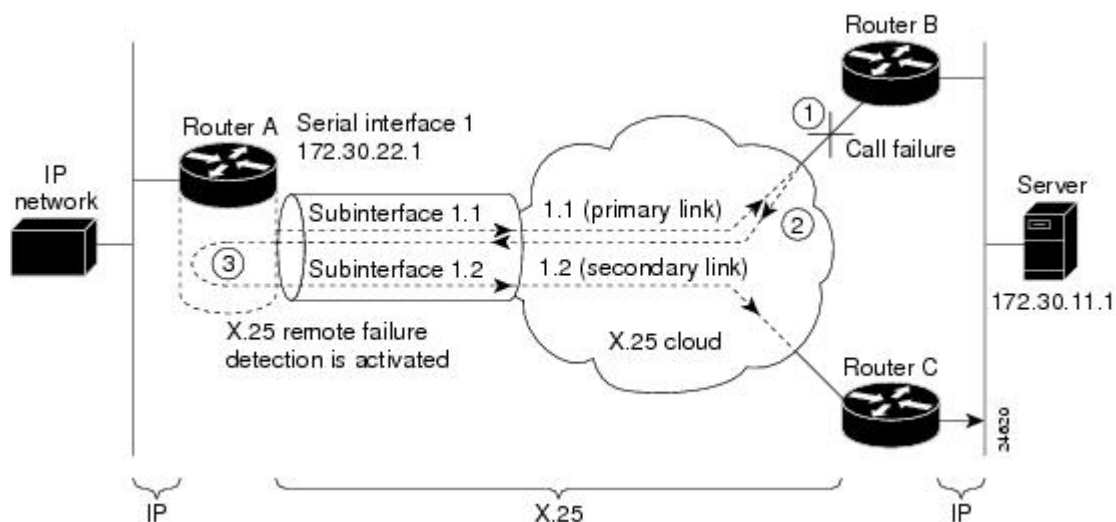

X.29 Access Lists

Protocol translation software supports access lists, which make it possible to limit access to the access server from X.25 hosts. Access lists take advantage of the message field defined by Recommendation X.29, which describes procedures for exchanging data between two PADs or between a PAD and a DTE device.

When configuring protocol translation, you can specify an access list number with each **translate** command. When translation sessions result from incoming PAD connections, the corresponding X.29 access list is used. Refer to the *Cisco IOS Dial Technologies Command Reference* for more information about the **translate** command.

An access list can contain any number of lines. The lists are processed in the order in which you type the entries. The first match causes the permit or deny condition. If an X.121 address does not match any of the entries in the access list, access is denied.

When applying the access list to a virtual terminal line, the access list number is used for incoming TCP access, for incoming local-area transport (LAT) access, and for incoming PAD access. For TCP access, the protocol translator uses the defined IP access lists. For LAT access, the protocol translator uses the defined LAT access list. For incoming PAD connections, the protocol translator uses an X.29 access list. If you want to have access restrictions only on one of the protocols, you can create an access list that permits all addresses for the other protocol.

How to Configure LAPB

- [Configuring a LAPB Datagram Transport](#), page 35
- [Selecting an Encapsulation and Protocol](#), page 35
- [Configuring Compression over LAPB](#), page 35
- [Configuring Compression over Multi-LAPB](#), page 36

- [Configuring Transparent Bridging over Multiprotocol LAPB, page 36](#)

Configuring a LAPB Datagram Transport

To set the appropriate LAPB encapsulation to run datagrams over a serial interface, use the following command in global configuration mode. One end of the link must be a DTE device, and the other must be DCE. Because the default serial encapsulation is HDLC, you must explicitly configure a LAPB encapsulation method. You should shut down the interface before changing the encapsulation.

Command	Purpose
Router(config)# interface <i>type number</i>	Specifies a serial interface.

Selecting an Encapsulation and Protocol

To select an encapsulation and protocol (if you are using a single protocol), or to select the multiple protocol operation, use one or more of the following commands in interface configuration mode:

Command	Purpose
Router(config-if)# encapsulation lapb dce [<i>protocol</i>] ⁷	Enables encapsulation of a single protocol on the line using DCE operation.
Router(config-if)# encapsulation lapb dte [<i>protocol</i>] Selecting an Encapsulation and Protocol, page 35	Enables encapsulation of a single protocol on the line using DTE operation.
Router(config-if)# encapsulation lapb dce multi	Enables use of multiple protocols on the line using DCE operation.
Router(config-if)# encapsulation lapb dte multi ⁸	Enable use of multiple protocols on the line using DTE operation.

Configuring Compression over LAPB

To configure compression over LAPB, use the following commands in interface configuration mode:

SUMMARY STEPS

1. Router(config-if)# **encapsulation lapb**[*protocol*]
2. Router(config-if)# **compress**[*predictor* | *stac*]

⁷

Single protocol LAPB defaults to IP encapsulation.

⁸ Multiprotocol LAPB does not support source-route bridging or TCP/IP header compression, but does support transparent bridging. A multiprotocol LAPB encapsulation supports all of the protocols available to a single-protocol LAPB encapsulation plus transparent bridging.

DETAILED STEPS

	Command or Action	Purpose
Step 1	Router(config-if)# encapsulation lapb [<i>protocol</i>]	Enables encapsulation of a single protocol on the serial line.
Step 2	Router(config-if)# compress [predictor stac]	Enables compression.

Configuring Compression over Multi-LAPB

To configure compression over multi-LAPB, use the following commands in interface configuration mode:

SUMMARY STEPS

1. Router(config-if)# **encapsulation lapb multi**
2. Router(config-if)# **compress**[**predictor** | **stac**]

DETAILED STEPS

	Command or Action	Purpose
Step 1	Router(config-if)# encapsulation lapb multi	Enables encapsulation of multiple protocols on the serial line.
Step 2	Router(config-if)# compress [predictor stac]	Enables compression.

When using compression, adjust the maximum transmission unit (MTU) for the serial interface and the LAPB N1 parameter as in the following example, to avoid informational diagnostics regarding excessive MTU or N1 sizes:

```
interface serial 0
 encapsulation lapb
 compress predictor
 mtu 1509
 lapb n1 12072
```

For information about configuring X.25 TCP/IP header compression and X.25 payload compression, see the sections [Setting X.25 TCP/IP Header Compression, page 46](#) and [Configuring X.25 Payload Compression, page 47](#).

Configuring Transparent Bridging over Multiprotocol LAPB

To configure transparent bridging over multiprotocol LAPB, use the following commands beginning in global configuration mode:

SUMMARY STEPS

1. Router(config)# **interface serial** *number*
2. Router(config-if)# **no ip address**
3. Router(config-if)# **encapsulation lapb multi**
4. Router(config-if)# **bridge-group** *bridge-group*
5. Router(config)# **bridge** *bridge-group* **protocol** {**ieee** | **dec**}

DETAILED STEPS

	Command or Action	Purpose
Step 1	Router(config)# interface serial <i>number</i>	Enters interface configuration mode.
Step 2	Router(config-if)# no ip address	Assigns no IP address to the interface.
Step 3	Router(config-if)# encapsulation lapb multi	Configures multiprotocol LAPB encapsulation. Note You must use the encapsulation lapb multi command rather than the encapsulation lapb protocol bridge command to configure transparent bridging over multiprotocol LAPB.
Step 4	Router(config-if)# bridge-group <i>bridge-group</i>	Assigns the interface to a bridge group.
Step 5	Router(config)# bridge <i>bridge-group</i> protocol {ieee dec}	Defines the type of Spanning-Tree Protocol.

How to Configure X.25

LAPB frame parameters can be modified to optimize X.25 operation and these features can coexist on an X.25 interface.

Default parameters are provided for X.25 operation. However, you can change the settings to meet the needs of your X.25 network or as defined by your X.25 service supplier. Cisco also provides additional configuration settings to optimize your X.25 usage.

**Note**

If you connect a router to an X.25 network, use the parameters set by your network administrator for the connection. These parameters are described in the sections "[Configuring an X.25 Interface, page 38](#)" and "[Modifying LAPB Protocol Parameters, page 3](#)". Also, note that the X.25 Level 2 parameters described in the section "[Modifying LAPB Protocol Parameters, page 3](#)" affect X.25 Level 3 operations.

- [Configuring an X.25 Interface, page 38](#)
- [Configuring Additional X.25 Interface Parameters, page 41](#)
- [Configuring an X.25 Datagram Transport, page 45](#)
- [Configuring Additional X.25 Datagram Transport Features, page 47](#)
- [Configuring X.25 Routing, page 51](#)
- [Configuring Additional X.25 Routing Features, page 54](#)
- [Configuring DNS-Based X.25 Routing, page 57](#)
- [Configuring X.25 over Frame Relay \(Annex G\), page 59](#)
- [Configuring CMNS Routing, page 59](#)
- [Configuring Priority Queueing or Custom Queueing for X.25, page 60](#)
- [Configuring X.25 Closed User Groups, page 61](#)
- [Configuring DDN or BFE X.25, page 65](#)
- [Configuring X.25 Remote Failure Detection, page 66](#)
- [Creating X.29 Access Lists, page 69](#)
- [Creating an X.29 Profile Script, page 70](#)

- [Monitoring and Maintaining LAPB and X.25](#), page 70

Configuring an X.25 Interface

- [Configuring X.25 Encapsulation](#), page 38
- [Setting the Virtual Circuit Ranges](#), page 38
- [Setting the Packet-Numbering Modulo](#), page 39
- [Setting the X.121 Address](#), page 39
- [Configuring X.25 Switch Local Acknowledgment](#), page 39
- [Enabling Flow Control Parameter Negotiation](#), page 40
- [Setting Default Flow Control Values](#), page 40
- [Enabling Asymmetrical Flow Control](#), page 41

Configuring X.25 Encapsulation

To configure the mode of operation and encapsulation type for a specified interface, use the following command in interface configuration mode:

Command	Purpose
Router(config-if)# encapsulation x25 [dte dce] [[ddn bfe] [ietf]]	Sets the X.25 mode of operation.

Setting the Virtual Circuit Ranges



Note

Each of these parameters can range from 1 to 4095. The values for these parameters must be the same on both ends of the X.25 link. For connection to a PDN, these values must be set to the values assigned by the network. An SVC range is unused if its lower and upper limits are set to 0; other than this use for marking unused ranges, VC 0 is not available.

To configure X.25 VC ranges, use the following commands in interface configuration mode:

Command	Purpose
Router(config-if)# x25 lic <i>circuit-number</i>	Sets the lowest incoming-only circuit number. The default is 0.
Router(config-if)# x25 hic <i>circuit-number</i>	Sets the highest incoming-only circuit number. The default is 0.
Router(config-if)# x25 ltc <i>circuit-number</i>	Sets the lowest two-way circuit number. The default is 1.
Router(config-if)# x25 htc <i>circuit-number</i>	Sets the highest two-way circuit number. The default is 1024 for X.25; 4095 for CMNS.

Command	Purpose
Router(config-if)# x25 loc <i>circuit-number</i>	Sets the lowest outgoing-only circuit number. The default is 0.
Router(config-if)# x25 hoc <i>circuit-number</i>	Sets the highest outgoing-only circuit number. The default is 0.

Setting the Packet-Numbering Modulo

To set the packet-numbering modulo, use the following command in interface configuration mode:

Command	Purpose
Router(config-if)# x25 modulo {8 128}	Sets the packet-numbering modulo.

Setting the X.121 Address

To set the X.121 address, use the following command in interface configuration mode:

Command	Purpose
Router(config-if)# x25 address <i>x121-address</i>	Sets the X.121 address.

Configuring X.25 Switch Local Acknowledgment

To configure local acknowledgment, use the following command in global configuration mode:

Command	Purpose
Router(config)# x25 routing acknowledge local	Enables X.25 switching with local acknowledgment.

- [Verifying Local Acknowledgement, page 39](#)

Verifying Local Acknowledgement

To verify that local acknowledgment is configured on your router, use the **show running-configuration** command in EXEC mode. In the following example, X.25 encapsulation has been set on serial interface 1/4 with acknowledgment set to "local":

```
Router# show running-configuration
x25 routing acknowledge local
```

You can also use the **show protocol** command in EXEC mode to verify local acknowledgment:

```
Router# show protocol
Global values:
  Internet Protocol routing is enabled
  X.25 routing is enabled, acknowledgements have local significance only
```

Enabling Flow Control Parameter Negotiation

To control packet transmission flow values on the interface, use one or more of the flow control commands in interface configuration mode.

Command	Purpose
Router(config-if)# x25 subscribe flow-control { always never }	Determines flow control parameter negotiation behavior.
Router(config-if)# x25 subscribe window-size { permit <i>wmin wmax</i> target <i>wmin wmax</i> }	Sets permitted and target ranges for window size negotiation.
Router(config-if)# x25 subscribe packet-size { permit <i>pmin pmax</i> target <i>pmin pmax</i> }	Sets permitted and target ranges for packet size negotiation.

- [Verifying Flow Control Parameter Negotiation, page 40](#)

Verifying Flow Control Parameter Negotiation

To verify flow control parameter settings, use the **show running-configuration** command in EXEC mode. In the following example, X.25 encapsulation has been set on serial interface 1/4 with flow control negotiation set to "always." Permitted packet sizes are set at 64 (minimum) and 1024 (maximum), with target packet sizes set at 128 (minimum) and 1024 (maximum). Permitted window sizes are set at 1 (minimum) and 7 (maximum), with target window sizes set at 2 (minimum) and 4 (maximum).

```
Router# show running-configuration
x25 subscribe flow-control always
x25 subscribe packet-size permit 64 1024 target 128 1024
x25 subscribe window-size permit 1 7 target 2 4
```

Setting Default Flow Control Values

- [Setting Default Window Sizes, page 40](#)
- [Setting Default Packet Sizes, page 41](#)

Setting Default Window Sizes

To set the default window sizes, use the following commands in interface configuration mode:

SUMMARY STEPS

1. Router(config-if)# **x25 win packets**
2. Router(config-if)# **x25 wout packets**

DETAILED STEPS

	Command or Action	Purpose
Step 1	Router(config-if)# x25 win packets	Sets input maximum window size.

	Command or Action	Purpose
Step 2	Router(config-if)# x25 wout <i>packets</i>	Sets output maximum window size.

Setting Default Packet Sizes

To set the default input and output maximum packet sizes, use the following commands in interface configuration mode:

SUMMARY STEPS

1. Router(config-if)# **x25 ips** *bytes*
2. Router(config-if)# **x25 ops** *bytes*

DETAILED STEPS

	Command or Action	Purpose
Step 1	Router(config-if)# x25 ips <i>bytes</i>	Sets input maximum packet size.
Step 2	Router(config-if)# x25 ops <i>bytes</i>	Sets output maximum packet size.

Enabling Asymmetrical Flow Control

To use asymmetrical flow control effectively, use the **x25 subscribe flow-control never** command to disable flow control parameter negotiation, and use the **x25 routing acknowledge local** command to enable local acknowledgment.

SUMMARY STEPS

1. Router(config)# **x25 routing acknowledge local**
2. Router(config-if)# **x25 subscribe flow-control never**

DETAILED STEPS

	Command or Action	Purpose
Step 1	Router(config)# x25 routing acknowledge local	Enables X.25 switching with local acknowledgment.
Step 2	Router(config-if)# x25 subscribe flow-control never	Disables flow control parameter negotiation behavior.

Configuring Additional X.25 Interface Parameters

- [Configuring X.25 Failover, page 42](#)
- [Configuring the X.25 Level 3 Timers, page 43](#)
- [Configuring X.25 Addresses, page 43](#)
- [Establishing a Default VC Protocol, page 44](#)
- [Disabling PLP Restarts, page 44](#)

Configuring X.25 Failover

You can configure X.25 Failover on an X.25 interface or X.25 profile.

- [Configuring X.25 Failover on an Interface](#), page 42
- [Configuring X.25 Failover on an X.25 Profile](#), page 42
- [Verifying X.25 Failover](#), page 43

Configuring X.25 Failover on an Interface

To configure X.25 failover on an interface, use the following commands beginning in global configuration mode:

SUMMARY STEPS

1. Router(config)# **interface** *type number*
2. Router(config-if)# **encapsulation x25**
3. Router(config-if)# **x25 fail-over** *seconds interface type number [dlci | MAC address]*

DETAILED STEPS

	Command or Action	Purpose
Step 1	Router(config)# interface <i>type number</i>	Configures an interface type and enters interface configuration mode.
Step 2	Router(config-if)# encapsulation x25	Specifies the operation of a serial interface as an X.25 device.
Step 3	Router(config-if)# x25 fail-over <i>seconds interface type number [dlci MAC address]</i>	Specifies a secondary interface and sets the number of seconds for which the primary interface must be up before the secondary interface resets.

Configuring X.25 Failover on an X.25 Profile

To configure X.25 failover on an X.25 profile, use the following commands beginning in global configuration mode:

SUMMARY STEPS

1. Router(config)# **x25 profile** *name* {dce | dte | dxe}
2. Router(config-x25)# **x25 fail-over** *seconds interface type number [dlci | MAC address]*

DETAILED STEPS

	Command or Action	Purpose
Step 1	Router(config)# x25 profile <i>name</i> {dce dte dxe}	Configures an X.25 profile.

Command or Action	Purpose
Step 2 Router(config-x25)# x25 fail-over <i>seconds</i> interface <i>type number [dlci MAC address]</i> Example:	Specifies a secondary interface and sets the number of seconds for which the primary interface must be up before the secondary interface resets.

Verifying X.25 Failover

To display information about the X.25 Failover feature, use the following EXEC command:

Command	Purpose
Router# show x25 context	Displays information about all X.25 links.

Configuring the X.25 Level 3 Timers

To set the event timers, use any of the following commands in interface configuration mode:

Command	Purpose
Router(config-if)# x25 t20 <i>seconds</i>	Sets DTE T20 Restart Request timeout.
Router(config-if)# x25 t10 <i>seconds</i>	Sets DCE T10 Restart Indication timeout.
Router(config-if)# x25 t21 <i>seconds</i>	Sets DTE T21 Call Request timeout.
Router(config-if)# x25 t11 <i>seconds</i>	Sets DCE T11 Incoming Call timeout.
Router(config-if)# x25 t22 <i>seconds</i>	Sets DTE T22 Reset Request timeout.
Router(config-if)# x25 t12 <i>seconds</i>	Sets DCE T12 Reset Indication timeout.
Router(config-if)# x25 t23 <i>seconds</i>	Sets DTE T23 Clear Request timeout.
Router(config-if)# x25 t13 <i>seconds</i>	Sets DCE T13 Clear Indication timeout.

For an example of setting the event timers, see the section "[DDN X.25 Configuration Example, page 90](#)" later in this chapter.

Configuring X.25 Addresses

- [Configuring an Interface Alias Address, page 44](#)
- [Suppressing or Replacing the Calling Address, page 44](#)

- [Suppressing the Called Address, page 44](#)

Configuring an Interface Alias Address

To configure an alias, use the following command in interface configuration mode:

Command	Purpose
<code>Router(config-if)# x25 alias <i>x121-address-pattern</i> [cu <i>pattern</i>]</code>	Enables an alias X.121 address for the interface.

Suppressing or Replacing the Calling Address

To suppress or replace the calling address, use the appropriate command in interface configuration mode:

Command	Purpose
<code>Router(config-if)# x25 suppress-calling-address</code>	Suppresses the calling (source) X.121 address in outgoing calls.
<code>Router(config-if)# x25 use-source-address</code>	Replaces the calling (source) X.121 address in switched calls.

Suppressing the Called Address

To suppress the called address, use the following command in interface configuration mode:

Command	Purpose
<code>Router(config-if)# x25 suppress-called-address</code>	Suppresses the called (destination) X.121 address in outgoing calls.

Establishing a Default VC Protocol

To configure either PAD or IP encapsulation treatment of unidentified calls, use the following command in interface configuration mode:

Command	Purpose
<code>Router(config-if)# x25 default {ip pad}</code>	Establishes a default VC protocol.

Disabling PLP Restarts

To disable PLP restarts, use the following command in interface configuration mode:

Command	Purpose
<code>Router(config-if)# no x25 linkrestart</code>	Disables packet-level restarts.

Configuring an X.25 Datagram Transport

- [Configuring Point-to-Point and Multipoint Subinterfaces, page 45](#)
- [Mapping Protocol Addresses to X.121 Addresses, page 45](#)
- [Establishing an Encapsulation PVC, page 46](#)
- [Setting X.25 TCP/IP Header Compression, page 46](#)
- [Configuring X.25 Bridging, page 46](#)

Configuring Point-to-Point and Multipoint Subinterfaces

To create and configure a subinterface, use the Step 1 command and one or both of the Step 2 commands beginning in global configuration mode:

SUMMARY STEPS

1. Router(config)# **interface serial** *type number . subinterface-number* [**point-to-point** | **multipoint**]
2. Do one of the following:
 - Router(config-subif)# **x25 map** *protocol address [protocol2 address2 [... [protocol9 address9]]] x121-address [option]*
 -
 - Router(config-subif)# **x25 pvc** *circuit protocol address [protocol2 address2 [... [protocol9 address9]]] x121-address [option]*

DETAILED STEPS

Command or Action	Purpose
Step 1 Router(config)# interface serial <i>type number . subinterface-number</i> [point-to-point multipoint]	Creates a point-to-point or multipoint subinterface.
Step 2 Do one of the following: <ul style="list-style-type: none"> • Router(config-subif)# x25 map <i>protocol address [protocol2 address2 [... [protocol9 address9]]] x121-address [option]</i> • • Router(config-subif)# x25 pvc <i>circuit protocol address [protocol2 address2 [... [protocol9 address9]]] x121-address [option]</i> 	Configures an X.25 encapsulation map for the subinterface. Establishes an encapsulation PVC for the subinterface.

Mapping Protocol Addresses to X.121 Addresses

- [Mapping Datagram Addresses to X.25 Hosts, page 45](#)
- [Configuring PAD Access, page 46](#)

Mapping Datagram Addresses to X.25 Hosts

To establish an X.25 map, use the following command in interface configuration mode:

Command	Purpose
Router(config-if)# x25 map <i>protocol address [protocol2 address2 [...[protocol9 address9]]] x121-address [option]</i>	Maps one or more host protocol addresses to the X.121 address of the host.

Configuring PAD Access

To restrict PAD connections only to statically mapped X.25 hosts, use the following commands in interface configuration mode:

SUMMARY STEPS

1. Router(config-if)# **x25 pad-access**
2. Router(config-if)# **x25 map pad** *x121-address[option]*

DETAILED STEPS

	Command or Action	Purpose
Step 1	Router(config-if)# x25 pad-access	Restricts PAD access.
Step 2	Router(config-if)# x25 map pad <i>x121-address[option]</i>	Configures a host for PAD access.

Establishing an Encapsulation PVC

To establish a PVC, use the following command in interface configuration mode:

Command	Purpose
Router(config-if)# x25 pvc <i>circuit protocol address [protocol2 address2 [...[protocol9 address9]]] x121-address [option]</i>	Sets an encapsulation PVC.

Setting X.25 TCP IP Header Compression

To set up a separate VC for X.25 THC, use the following command in interface configuration mode:

Command	Purpose
Router(config-if)# x25 map compressedtcp <i>ip-address [protocol2 address2 [...[protocol9 address9]]] x121-address [option]</i>	Allows a separate VC for compressed packets.

Configuring X.25 Bridging

To enable the X.25 bridging capability, use the following command in interface configuration mode:

Command	Purpose
Router(config-if)# x25 map bridge <i>x121-address</i> broadcast [<i>option</i>]	Defines bridging of X.25 frames.

Configuring Additional X.25 Datagram Transport Features

- [Configuring X.25 Payload Compression, page 47](#)
- [Configuring the Encapsulation VC Idle Time, page 47](#)
- [Increasing the Number of VCs Allowed, page 48](#)
- [Configuring the Ignore Destination Time, page 48](#)
- [Establishing the Packet Acknowledgment Policy, page 48](#)
- [Configuring X.25 User Facilities, page 48](#)
- [Defining the VC Packet Hold Queue Size, page 50](#)
- [Restricting Map Usage, page 51](#)

Configuring X.25 Payload Compression

To enable payload compression over X.25, use the following command in interface configuration mode:

Command	Purpose
Router(config-if)# x25 map <i>protocol address</i> [<i>protocol2 address2</i> [... <i>protocol9 address9</i>]] <i>x121-address</i> compress	Enables payload compression over X.25.

Configuring the Encapsulation VC Idle Time

The Cisco IOS software can clear a datagram transport or PAD SVC after a set period of inactivity. Routed SVCs are not timed for inactivity.

To set the time, use the following commands in interface configuration mode:

SUMMARY STEPS

1. Router(config-if)# **x25 idle** *minutes*
2. Router(config-if)# **x25 map** *protocol address*[*protocol2 address2* [...*protocol9 address9*]] *x121-address* **idle** *minutes*

DETAILED STEPS

	Command or Action	Purpose
Step 1	Router(config-if)# x25 idle <i>minutes</i>	Sets an idle time for clearing encapsulation.
Step 2	Router(config-if)# x25 map <i>protocol address</i> [<i>protocol2 address2</i> [... <i>protocol9 address9</i>]] <i>x121-address</i> idle <i>minutes</i>	Specifies idle time for clearing SVCs of a map.

Increasing the Number of VCs Allowed

For X.25 datagram transport, you can establish up to eight VCs to one host for each map. To increase the number of VCs allowed, use one or both of the following commands in interface configuration mode:

Command	Purpose
Router(config-if)# x25 nvc <i>count</i>	Specifies the default maximum number of SVCs that can be open simultaneously to one host for each map.
Router(config-if)# x25 map <i>protocol address [protocol2 address2 [...[protocol9 address9]]] x121-address nvc</i> <i>count</i>	Specifies the maximum number of SVCs allowed for a map.

Configuring the Ignore Destination Time

Upon receiving a Clear for an outstanding datagram transport Call Request, the X.25 encapsulation code immediately tries another Call Request if it has more traffic to send. This action can overrun some X.25 switches. To define the number of minutes for which the Cisco IOS software will prevent calls from going to a previously failed destination, use the following command in interface configuration mode (incoming calls will still be accepted and cancel the timer):

Command	Purpose
Router(config-if)# x25 hold-vc-timer <i>minutes</i>	Configures the ignore destination time.

Establishing the Packet Acknowledgment Policy

To establish the acknowledgment threshold, use the following command in interface configuration mode (the packet acknowledgment threshold also applies to encapsulation PVCs):

Command	Purpose
Router(config-if)# x25 threshold <i>delay-count</i>	Sets data packet acknowledgement threshold.

Configuring X.25 User Facilities

To set the supported X.25 user facilities options, use one or more of the following commands in interface configuration mode:

Command	Purpose
<pre>Router(config-if)# x25 facility cug <i>number</i></pre> <p>or</p> <pre>x25 map <i>protocol address</i> [<i>protocol2 address2</i> [...[<i>protocol9 address9</i>]]] <i>x121-address</i> cug <i>group-number</i></pre>	Selects the closed user group (CUG).
<pre>Router(config-if)# x25 facility packetsize <i>in-size out-size</i></pre> <p>or</p> <pre>Router(config-if)# x25 map <i>protocol address</i> [<i>protocol2 address2</i> [...[<i>protocol9</i> <i>address9</i>]]] <i>x121-address</i> packetsize <i>in-size</i> <i>out-size</i></pre> <p>or</p> <pre>Router(config-if)# x25 facility windowsize <i>in-size out-size</i></pre> <p>or</p> <pre>Router(config-if)# x25 map <i>protocol address</i> [<i>protocol2 address2</i> [...[<i>protocol9</i> <i>address9</i>]]] <i>x121-address</i> windowsize <i>in-size</i> <i>out-size</i></pre>	Sets the flow control parameter negotiation values to be requested on outgoing calls.
<pre>Router(config-if)# x25 facility reverse</pre> <p>or</p> <pre>Router(config-if)# x25 map <i>protocol address</i> [<i>protocol2 address2</i> [...[<i>protocol9</i> <i>address9</i>]]] <i>x121-address</i> reverse</pre>	Sets reverse charging.
<pre>Router(config-if)# x25 accept-reverse</pre> <p>or</p> <pre>Router(config-if)# x25 map <i>protocol address</i> [<i>protocol2 address2</i> [...[<i>protocol9</i> <i>address9</i>]]] <i>x121-address</i> accept-reverse</pre>	Allows reverse charging acceptance.

Command	Purpose
<pre>Router(config-if)# x25 facility throughput in out</pre> <p>or</p> <pre>Router(config-if)# x25 map protocol address [protocol2 address2 [...[protocol9 address9]]] x121-address throughput in out</pre>	Selects throughput class negotiation.
<pre>Router(config-if)# x25 facility transit-delay milliseconds</pre> <p>or</p> <pre>Router(config-if)# x25 map protocol address [protocol2 address2 [...[protocol9 address9]]] x121-address transit-delay milliseconds</pre>	Selects transit delay.
<pre>Router(config-if)# x25 facility roa name</pre> <p>or</p> <pre>Router(config-if)# x25 map protocol address [protocol2 address2 [...[protocol9 address9]]] x121-address roa name</pre>	Sets which Recognized Operating Agency (ROA) to use.
<pre>Router(config-if)# x25 map protocol address [protocol2 address2 [...[protocol9 address9]]] x121-address nuid username password</pre>	Sets the Cisco standard network user identification.
<pre>Router(config-if)# x25 map protocol address [protocol2 address2 [...[protocol9 address9]]] x121-address nudata string</pre>	Sets a user-defined network user identification, allowing the format to be determined by your network administrator.

Defining the VC Packet Hold Queue Size

To define the maximum number of packets that can be held while a VC is unable to send data, use the following command in interface configuration mode. A hold queue size of an encapsulation VC is determined when it is created; the **x25 hold-queue** command does not affect existing VCs. This command also defines the hold queue size of encapsulation PVCs.

Command	Purpose
Router(config-if)# x25 hold-queue <i>packets</i>	Defines the VC packet hold queue size.

Restricting Map Usage

An X.25 map can be restricted so that it will not be used to place calls or so that it will not be considered when incoming calls are mapped. To restrict X.25 map usage, use the following commands in interface configuration mode:

Command	Purpose
Router(config-if)# x25 map <i>protocol address</i> [<i>protocol2 address2</i> [... [<i>protocol9 address9</i>]]] <i>x121-address</i> no-incoming	Restricts incoming calls from a map.
Router(config-if)# x25 map <i>protocol address</i> [<i>protocol2 address2</i> [... [<i>protocol9 address9</i>]]] <i>x121-address</i> no-outgoing	Restricts outgoing calls from a map.

Configuring X.25 Routing

- [Enabling X.25 Routing, page 51](#)
- [Configuring an X.25 Route, page 51](#)
- [Configuring a PVC Switched Between X.25 Interfaces, page 53](#)
- [Configuring X.25 Switching Between PVCs and SVCs, page 54](#)

Enabling X.25 Routing

You must enable X.25 routing to use switch VCs. To enable X.25 routing, use the following command in global configuration mode:

Command	Purpose
Router(config)# x25 routing [use-tcp-if-defs]	Enables X.25 routing. The use-tcp-if-defs keyword is used by some routers that receive remote routed calls from older versions of XOT; it might be needed if the originating router cannot be updated to a new software release. This keyword is described in the " Configuring XOT to Use Interface Default Flow Control Values, page 55 " section.

Configuring an X.25 Route

To configure an X.25 route (thus adding the route to the X.25 routing table), use the following command in global configuration mode:

Command	Purpose
<pre>Router(config)# x25 route [#position] [selection-options] [modification-options] disposition-options [xot-keepalive-options]</pre>	<p>Configures an X.25 route.</p> <ul style="list-style-type: none"> • <i>#position</i> --Indicate the number of the entry in the route table. For example, #9 indicates the ninth entry from the top. The route table is always searched sequentially from the top, and the first match found will be used. • <i>selection-options</i> --Criteria to define the VCs to which the route will apply. You can match against zero to four of the following optional <i>selection</i> elements: <ul style="list-style-type: none"> ◦ <i>destination-pattern</i> ◦ source <i>source-pattern</i> ◦ dest-ext <i>nsap-destination-pattern</i> ◦ culd <i>user-data-pattern</i> • <i>modification-options</i> --Modifications to the source or destination address for address translation. You can use neither, one, or both of the following optional <i>modification</i> elements to change the source or destination address before forwarding the call to the destination: <ul style="list-style-type: none"> ◦ substitute-source <i>rewrite-source</i> ◦ substitute-dest <i>rewrite-destination</i> <p>Note You must include a selection option or a modification option in an x25 route command.</p>
	<ul style="list-style-type: none"> • <i>disposition-options</i> --Where the VC will be forwarded or whether it will be cleared. You are required to use one of the following <i>disposition</i> elements: <ul style="list-style-type: none"> ◦ interface <i>serial-interface</i>--A route to a specific <i>serial-interface</i> will send the VC to an X.25 service on a synchronous serial interface. ◦ interface <i>cmns-interface</i> mac <i>mac-address</i>--A route to a broadcast interface will send the VC to a CMNS partner reachable on a broadcast medium at a specified MAC address. The CMNS interface can be an Ethernet, Token Ring, or FDDI interface. ◦ xot <i>ip-address[ip2-address [...[ip6-address]]]</i> [xot-source <i>interface</i>] <p>A route to an xot destination (formerly called a <i>remote</i> or <i>tunneled</i> configuration) will send the VC</p>

Command	Purpose
	<p>to the XOT service for establishment of a TCP connection across which the XOT VC packets will travel. An xot disposition may specify alternate destinations to try if a TCP connection cannot be established for all preceding destinations.</p> <ul style="list-style-type: none"> • ◦ clear-- A route to a clear destination will deny further service to the VC by shutting down the connection. • <i>xot-keepalive -options --</i>You can use neither, one, or both of the following optional <i>xot-keepalive</i> elements: <ul style="list-style-type: none"> ◦ xot-keepalive-period <i>seconds</i> <p>xot-keepalive-tries <i>count</i></p>

Configuring a PVC Switched Between X.25 Interfaces

You can configure an X.25 PVC in the X.25 switching software. As a result, DTE devices that require permanent circuits can be connected to a router acting as an X.25 switch and have a properly functioning connection. X.25 resets will be sent to indicate when the circuit comes up or goes down. Both interfaces must define complementary locally switched PVCs.

- [Configuring a Locally Switched PVC, page 53](#)
- [Ensuring the TCP sessions are Connected, page 53](#)

Configuring a Locally Switched PVC

To configure a locally switched PVC, use the following command in interface configuration mod:

Command	Purpose
<pre>Router(config-if)# x25 pvc <i>number1</i> interface <i>type number pvc number2</i> [<i>option</i>]</pre>	<p>Configures a locally switched PVC. The command options are packetsize <i>in out</i> and window <i>size in out</i>; they allow the flow control values of a PVC to be defined if they differ from the interface defaults.</p>

Ensuring the TCP sessions are Connected

To ensure that TCP sessions remain connected in the absence of XOT traffic, use the following command in global configuration mode. TCP keepalives also inform a router when an XOT SVC session is not active, thus freeing router resources.

Command	Purpose
<pre>Router(config)# service tcp-keepalives-in</pre>	<p>Enables received keepalives for TCP sessions to ensure timely detection of a connection failure.</p>

Command	Purpose
Router(config)# service tcp-keepalives-out	Enables sent keepalives for TCP sessions to ensure timely detection of a connection failure.

Configuring X.25 Switching Between PVCs and SVCs

In order for PVC to SVC switching to be configured between two serial interfaces, both interfaces must already be configured for X.25. In addition, X.25 switching must be enabled using the **x25 routing** global configuration command. The PVC interface must be a serial interface configured with X.25 encapsulation. (The SVC interface may use X.25, XOT, or CMNS.) To configure X.25 switching between PVCs and SVCs, use the following command in interface configuration mode. X.25 switching must already be configured on the interface.

Command	Purpose
Router(config-if)# x25 pvc <i>number1</i> svc <i>x121-address</i> [<i>flow-control-options</i>] [<i>call-control-options</i>]	Configures PVC traffic to be forwarded to an SVC.

- [Displaying the Switched Information, page 54](#)

Displaying the Switched Information

To display information about the switched PVC to SVC circuit, use the following command in EXEC mode:

Command	Purpose
Router(config)# show x25 vc [<i>lcn</i>]]	Displays information about the active SVCs and PVCs.

Configuring Additional X.25 Routing Features

- [Configuring X.25 Load Balancing, page 54](#)
- [Configuring XOT to Use Interface Default Flow Control Values, page 55](#)
- [Configuring Calling Address Interface-Based Insertion and Removal, page 55](#)
- [Substituting Addresses in an X.25 Route, page 56](#)
- [Configuring XOT Alternate Destinations, page 57](#)

Configuring X.25 Load Balancing

Before enabling X.25 load balancing, you must activate the X.25 routing software and configure the interfaces participating in the hunt group for X.25 encapsulation. To configure X.25 load balancing, use the following commands beginning in global configuration mode:

SUMMARY STEPS

1. Router(config)# **x25 routing**
2. Router(config)# **encapsulation x25**
3. Router(config)# **x25 hunt-group** *name* { **rotary** | **vc-count** }
4. Router(config)# **x25 route** [*#position*] [*selection-options*] [*modification-options*] *disposition-options* [*xot-keepalive-options*]

DETAILED STEPS

	Command or Action	Purpose
Step 1	Router(config)# x25 routing	Activates X.25 routing software.
Step 2	Router(config)# encapsulation x25	Specifies X.25 encapsulation on each hunt group interface.
Step 3	Router(config)# x25 hunt-group <i>name</i> { rotary vc-count }	Creates the hunt group.
Step 4	Router(config)# x25 route [<i>#position</i>] [<i>selection-options</i>] [<i>modification-options</i>] <i>disposition-options</i> [<i>xot-keepalive-options</i>]	Adds the hunt group to the routing table.

For examples of configuring X.25 load balancing, see the section "[X.25 Load Balancing Examples](#), page 78" later in this chapter.

- [Verifying X.25 Load Balancing](#), page 55

Verifying X.25 Load Balancing

To verify X.25 load balancing, use the following command in EXEC mode:

Command	Purpose
Router# show x25 hunt-group	Displays hunt groups and detailed interface statistics and distribution methods.

Configuring XOT to Use Interface Default Flow Control Values

To configure this behavior, use the following command when enabling X.25 routing in global configuration mode:

Command	Purpose
Router(config)# x25 routing [tcp-use-if-defs]	Enables X.25 routing and optionally modifies XOT source of unencoded flow control values.

Configuring Calling Address Interface-Based Insertion and Removal

To configure an input interface-based route statement into the X.121 address routing table, use either of the following commands beginning in global configuration command mode:

Command	Purpose
<pre>Router(config)# x25 route input-interface interface source source-pattern substitute- source rewrite-source [continue]</pre>	<p>Inserts an input interface-based route statement into the routing table.</p>
<p>or</p> <pre>Router(config)# x25 route input-interface interface disposition</pre>	<p>Inserts simplest input interface-based statement into the routing table.</p> <p>continue --(Optional) Performs address substitution without address forwarding. That is, it executes the address substitution instructions in each statement, but then stops short of actual call switching, thereby postponing the actual switching process until a matching route statement with a disposition other than continue is reached. The continue keyword is most useful when you switch calls among four or more routes. If your network has three or fewer routes, the continue keyword will not save any steps.</p>

- [Verifying Interface-Based Calling Address Insertion, page 56](#)

Verifying Interface-Based Calling Address Insertion

SUMMARY STEPS

1. To display the routes assigned by the **x25 route** command, use the **show x25 route** command in EXEC mode. A sample display follows.

DETAILED STEPS

To display the routes assigned by the **x25 route** command, use the **show x25 route** command in EXEC mode. A sample display follows.

Router# **show x25 route**

Example:

```
# Match          Substitute          Route to
1 dest ^01 input-int Serial0  Sub-dest \1      Sub-source 00\0 Serial1
```

Substituting Addresses in an X.25 Route

When interconnecting two separate X.25 networks, you must sometimes provide address substitution for routes. The **x25 route** command supports modification of X.25 source and destination addresses.

**Note**

Address substitution is available for all applications of X.25 routes.

To modify addresses, use either or both of the following commands in global configuration mode:

Command	Purpose
<pre>Router(config)# x25 route [#position] destination-pattern {source source-pattern substitute-source rewrite-source} interface interface number</pre>	Modifies the X.25 source address.
<pre>Router(config)# x25 route [#position] destination-pattern {source source-pattern substitute-dest rewrite-dest} interface interface number</pre>	Modifies the X.25 destination address.

Configuring XOT Alternate Destinations

Routes to XOT hosts can be configured with alternate destination hosts. On routing a call, XOT will try each XOT destination host in sequence; if the TCP connection attempt fails, the next destination will be tried. Up to six XOT destination addresses can be entered.

**Note**

Because of TCP timings, it can take up to 50 seconds to try an alternate route.

To configure an XOT route with alternate destinations (thus adding it to the X.25 routing table), use the following command in global configuration mode (the sequence of alternate destination XOT host addresses is added to the **x25 route** command using the *xot keepalive-options*):

Command	Purpose
<pre>Router(config)# x25 route [#position] destination-pattern xot ip-address [ip-address2 ... [ip-address6]]</pre>	Configures an XOT route. Optionally defines alternate XOT destination hosts.

Configuring DNS-Based X.25 Routing

To configure DNS-based X.25 routing, use the following command in global configuration mode. This task assumes that you already have XOT and DNS configured and enabled and that the route table in the DNS server has been correctly organized.

Command	Purpose
<pre>Router(config)# x25 route x121address xot dns pattern</pre>	Configures XOT routing to search for IP addresses in DNS.

For an example of configuring DNS-based X.25 routing, see the section [DNS-Based X.25 Routing Example](#), page 82 later in this chapter.

- [Verifying DNS-Based X.25 Routing, page 58](#)
- [Verifying DNS-Based X.25 Mnemonic Resolution, page 58](#)

Verifying DNS-Based X.25 Routing

SUMMARY STEPS

1. To verify that the DNS-Based X.25 Routing feature is configured, use the **show x25 route** command in EXEC mode:
2. If DNS-based X.25 routing is not functioning correctly, check that your DNS is configured properly and operating correctly as follows:

DETAILED STEPS

Step 1 To verify that the DNS-Based X.25 Routing feature is configured, use the **show x25 route** command in EXEC mode:

Example:

```
Router# show x25 route
# Match          Substitute      Route to
1 dest 444       xot dns \0
2 dest 555       xot dns \0
```

Step 2 If DNS-based X.25 routing is not functioning correctly, check that your DNS is configured properly and operating correctly as follows:

- Use the **show hosts** command to display temporary entries cached by DNS at the router.
- Use **debug x25 events** and **debug domain** commands to display current data flow. See the *Cisco IOS Debug Command Reference* for more information.

Verifying DNS-Based X.25 Mnemonic Resolution

SUMMARY STEPS

1. To verify DNS-based X.25 mnemonic resolution, use the **show hosts** command in EXEC mode. All permanent (perm) entries of type X.121 should be removed from the route table for DNS-based X.25 routing to work.

DETAILED STEPS

To verify DNS-based X.25 mnemonic resolution, use the **show hosts** command in EXEC mode. All permanent (perm) entries of type X.121 should be removed from the route table for DNS-based X.25 routing to work.

In the following example, the mnemonic "destination_host" is showing itself to be a permanent entry:

Example:

```
Router# show hosts
Default domain is home.com
Name/address lookup uses domain service
Name servers are 10.1.1.40

Host                Flags      Age Type  Address(es)
destination_host    (perm, OK) 1 X.121  222
```

Configuring X.25 over Frame Relay (Annex G)

To configure an Annex G connection (assuming you have already configured a Frame Relay connection on your router), use the following commands beginning in global configuration mode:

SUMMARY STEPS

1. Router(config)# **x25 profile name**
2. Router(config)# **interface type number**
3. Router(config-if)# **encapsulation frame-relay**
4. Router(config-if)# **frame-relay interface-dlci**
5. Router(config-fr-dlci)# **x25-profile name**
6. Router(config)# **x25 routing**
7. Router(config)# **x25 route number interface serial-interface dlci number**

DETAILED STEPS

	Command or Action	Purpose
Step 1	Router(config)# x25 profile name	Creates the X.25 profile.
Step 2	Router(config)# interface type number	Configures an interface.
Step 3	Router(config-if)# encapsulation frame-relay	Activates Frame Relay encapsulation on each interface that will be using Annex G connections.
Step 4	Router(config-if)# frame-relay interface-dlci	Configures the Frame Relay DLCI.
Step 5	Router(config-fr-dlci)# x25-profile name	Assigns the named X.25 profile to the DLCI.
Step 6	Router(config)# x25 routing	(Optional) Enables X.25 routing of outgoing calls.
Step 7	Router(config)# x25 route number interface serial-interface dlci number	(Optional) Assigns an X.25 route for the DLCI on that interface. Required if you want the router to accept switched calls, as well as originating them.

Configuring CMNS Routing

- [Enabling CMNS on an Interface, page 60](#)
- [Configuring a Route to a CMNS Host, page 60](#)

Enabling CMNS on an Interface

To enable CMNS on a nonserial interface, use the following command in interface configuration mode:

Command	Purpose
Router(config-if)# cmns enable	Enables CMNS.

Configuring a Route to a CMNS Host

Once CMNS is enabled on a nonserial interface, the router can forward calls over that medium by configuring **x25 route** commands that define the MAC address of each CMNS host that can be reached. To define routes to CMNS hosts, use the following command--plus pattern and character match options for the **x25 route** command--in interface configuration mode:

Command	Purpose
Router(config)# x25 route pattern-character match options interface <i>cmns-interface</i> mac <i>mac-address</i>	Defines route to CMNS host.

Configuring Priority Queueing or Custom Queueing for X.25

To configure priority queueing and custom queueing for X.25, perform the following steps:

SUMMARY STEPS

1. Perform the standard priority and custom queueing tasks *except* the task of assigning a priority or custom group to the interface, as described in the chapters "Configuring Priority Queueing" and "Configuring Custom Queueing" in the *Cisco IOS Quality of Service Solutions Configuration Guide* .
2. Perform the standard X.25 encapsulation tasks, as specified in the section "[Configuring an X.25 Datagram Transport, page 45](#)" earlier in this chapter.
3. Assign either a priority group or a custom queue to the interface, as described in the chapters "Configuring Priority Queueing" and "Configuring Custom Queueing" in the *Cisco IOS Quality of Service Solutions Configuration Guide* .

DETAILED STEPS

-
- | | |
|---------------|--|
| Step 1 | Perform the standard priority and custom queueing tasks <i>except</i> the task of assigning a priority or custom group to the interface, as described in the chapters "Configuring Priority Queueing" and "Configuring Custom Queueing" in the <i>Cisco IOS Quality of Service Solutions Configuration Guide</i> . |
| Step 2 | Perform the standard X.25 encapsulation tasks, as specified in the section " Configuring an X.25 Datagram Transport, page 45 " earlier in this chapter. |
| Step 3 | Assign either a priority group or a custom queue to the interface, as described in the chapters "Configuring Priority Queueing" and "Configuring Custom Queueing" in the <i>Cisco IOS Quality of Service Solutions Configuration Guide</i> . |
-

Configuring X.25 Closed User Groups

- [Configuring X.25 CUG Service Access and Properties](#), page 61
- [Configuring a POP with No CUG Access](#), page 61
- [Configuring a POP with Access Restricted to One CUG](#), page 62
- [Configuring a POP with Multiple CUGs and No Public Access](#), page 62
- [Configuring a POP with Multiple CUGs and Public Access](#), page 63
- [Configuring CUG Selection Facility Suppression](#), page 64
- [Verifying X.25 CUG Service](#), page 65
- [Troubleshooting Tips for X.25 CUG Service](#), page 65

Configuring X.25 CUG Service Access and Properties

To configure X.25 CUG service, access, and properties, use the following commands beginning in global configuration mode:

SUMMARY STEPS

1. Router(config)# **interface** *number*
2. Router(config-if)# **encapsulation x25 dce**
3. Router(config-if)# **x25 subscribe cug-service** [**incoming-access** | **outgoing-access**]
4. Router(config-if)# **x25 subscribe local-cug** *number* **network-cug** *number* [**no-incoming** | **no-outgoing** | **preferential**]

DETAILED STEPS

	Command or Action	Purpose
Step 1	Router(config)# interface <i>number</i>	Selects the interface to be configured.
Step 2	Router(config-if)# encapsulation x25 dce	Enables X.25 DCE network operation.
Step 3	Router(config-if)# x25 subscribe cug-service [incoming-access outgoing-access]	Enables and controls standard CUG behavior on an X.25 DCE interface.
Step 4	Router(config-if)# x25 subscribe local-cug <i>number</i> network-cug <i>number</i> [no-incoming no-outgoing preferential]	Maps the desired local CUG number to its corresponding network CUG.

Configuring a POP with No CUG Access

To configure a POP with no CUG access, use the following commands beginning in global configuration mode:

SUMMARY STEPS

1. Router(config)# **interface** *number*
2. Router(config-if)# **encapsulation x25 dce**
3. Router(config-if)# **x25 subscribe cug-service incoming-access outgoing-access**

DETAILED STEPS

	Command or Action	Purpose
Step 1	Router(config)# interface <i>number</i>	Selects the interface to be configured.
Step 2	Router(config-if)# encapsulation x25 dce	Enables X.25 DCE network operation.
Step 3	Router(config-if)# x25 subscribe cug-service incoming-access outgoing-access	Permits incoming and outgoing CUG access on an X.25 DCE interface.

Configuring a POP with Access Restricted to One CUG

To configure a POP with access restricted to one CUG, use the following commands beginning in global configuration mode:

SUMMARY STEPS

1. Router(config)# **interface** *number*
2. Router(config-if)# **encapsulation x25 dce**
3. Router(config-if)# **x25 subscribe cug-service**
4. Router(config-if)# **x25 subscribe local-cug** *number* **network-cug** *number* [**no-incoming** | **no-outgoing** | **preferential**]

DETAILED STEPS

	Command or Action	Purpose
Step 1	Router(config)# interface <i>number</i>	Selects the interface to be configured.
Step 2	Router(config-if)# encapsulation x25 dce	Enables X.25 DCE network operation.
Step 3	Router(config-if)# x25 subscribe cug-service	Sets default behavior on an X.25 DCE interface.
Step 4	Router(config-if)# x25 subscribe local-cug <i>number</i> network-cug <i>number</i> [no-incoming no-outgoing preferential]	Maps the desired local CUG number to its corresponding network CUG.

Configuring a POP with Multiple CUGs and No Public Access

To configure a POP with multiple CUGs and no public access, use the following commands beginning in global configuration mode:

SUMMARY STEPS

1. Router(config)# **interface** *number*
2. Router(config-if)# **encapsulation x25 dce**
3. Router(config-if)# **x25 subscribe cug-service**
4. Router(config-if)# **x25 subscribe local-cug** *number* **network-cug** *number* [**no-incoming** | **no-outgoing** | **preferential**]
5. Router(config-if)# **x25 subscribe local-cug** *number* **network-cug** *number* [**no-incoming** | **no-outgoing** | **preferential**]

DETAILED STEPS

	Command or Action	Purpose
Step 1	Router(config)# interface <i>number</i>	Selects the interface to be configured.
Step 2	Router(config-if)# encapsulation x25 dce	Enables X.25 DCE network operation.
Step 3	Router(config-if)# x25 subscribe cug-service	Sets default CUG behavior on an X.25 DCE interface.
Step 4	Router(config-if)# x25 subscribe local-cug <i>number</i> network-cug <i>number</i> [no-incoming no-outgoing preferential]	Maps the desired local CUG number to its corresponding network CUG.
Step 5	Router(config-if)# x25 subscribe local-cug <i>number</i> network-cug <i>number</i> [no-incoming no-outgoing preferential]	Configures another CUG interface.

Configuring a POP with Multiple CUGs and Public Access

To configure a POP with multiple CUGs and public access, use the following commands beginning in global configuration mode:

SUMMARY STEPS

1. Router(config)# **interface** *number*
2. Router(config-if)# **encapsulation x25 dce**
3. Router(config-if)# **x25 subscribe cug-service incoming-access outgoing-access**
4. Router(config-if)# **x25 subscribe local-cug** *number* **network-cug** *number* [**no-incoming** | **no-outgoing** | **preferential**]
5. Router(config-if)# **x25 subscribe local-cug** *number* **network-cug** *number* [**no-incoming** | **no-outgoing** | **preferential**]

DETAILED STEPS

	Command or Action	Purpose
Step 1	Router(config)# interface <i>number</i>	Selects the interface to be configured.
Step 2	Router(config-if)# encapsulation x25 dce	Enables X.25 DCE network operation.

	Command or Action	Purpose
Step 3	Router(config-if)# x25 subscribe cug-service incoming-access outgoing-access	Permits incoming and outgoing CUG access on an X.25 DCE interface.
Step 4	Router(config-if)# x25 subscribe local-cug number network-cug number [no-incoming no-outgoing preferential]	Maps the desired local CUG number to its corresponding network CUG.
Step 5	Router(config-if)# x25 subscribe local-cug number network-cug number [no-incoming no-outgoing preferential]	Configures another CUG interface.

Configuring CUG Selection Facility Suppression

- [Configuring CUG Selection Facility Suppression on an Interface, page 64](#)
- [Configuring CUG Selection Facility Suppression on an X.25 Profile, page 64](#)

Configuring CUG Selection Facility Suppression on an Interface

To configure X.25 CUG selection facility suppression on an interface, use the following commands beginning in global configuration mode:

SUMMARY STEPS

1. Router(config)# **interface type number**
2. Router(config-if)# **encapsulation x25 dce**
3. Router(config-if)# **x25 subscribe cug-service [incoming-access | outgoing-access] [suppress preferential | suppress all**

DETAILED STEPS

	Command or Action	Purpose
Step 1	Router(config)# interface type number	Configures an interface type and enters interface configuration mode.
Step 2	Router(config-if)# encapsulation x25 dce	Specifies that a serial interface will operate as an X.25 DCE device.
Step 3	Router(config-if)# x25 subscribe cug-service [incoming-access outgoing-access] [suppress preferential suppress all	Enables and controls standard CUG behavior on an X.25 DCE interface.

Configuring CUG Selection Facility Suppression on an X.25 Profile

To configure X.25 CUG selection facility suppression on an X.25 profile, use the following commands beginning in global configuration mode:

SUMMARY STEPS

1. Router(config)# **x25 profile name dce**
2. Router(config-x25)# **x25 subscribe cug-service** [incoming-access | outgoing-access] [**suppress preferential** | **suppress all**]

DETAILED STEPS

	Command or Action	Purpose
Step 1	Router(config)# x25 profile name dce	Configures an X.25 profile and specifies a DCE station type.
Step 2	Router(config-x25)# x25 subscribe cug-service [incoming-access outgoing-access] [suppress preferential suppress all]	Enables and controls standard CUG behavior on an X.25 DCE interface.

Verifying X.25 CUG Service

To show current settings of the X.25 CUGs feature, use the **show x25 cug** (either keyword **local-cug** or **network-cug** must be designated) command in EXEC mode. In the following example local CUGs 100, 200, 300, and 5000 are shown mapped to their related network CUGs 11, 22, 33, and 55, respectively, all with incoming and outgoing public access, and with network CUG 55 being set as the preferential:

```
Router# show x25 cug local-cug
X.25 Serial0, 4 CUGs subscribed with incoming and outgoing public access
local-cug 100 <-> network-cug 11
local-cug 200 <-> network-cug 22
local-cug 300 <-> network-cug 33
local-cug 5000 <-> network-cug 55, preferential
```

Troubleshooting Tips for X.25 CUG Service

You can use **debug x25 events** command to verify if and when CUG calls are being made and how the CUGs are behaving. The following example shows messages concerning a rejection of a call by a DCE because CUG 40 is not configured at the DCE interface, either by design or by administrative mistake:

```
Router# debug x25 events
00:48:33:Serial1:X.25 I R1 Call (14) 8 lci 1024
00:48:33: From (3):111 To (3):444
00:48:33: Facilities:(2)
00:48:33: Closed User Group (basic):40
00:48:33: Call User Data (4):0x01000000 (pad)
00:48:33:X.25 Incoming Call packet, Closed User Group (CUG) protection, selected network
CUG not subscribed
00:48:33:Serial1:X.25 O R1 Clear (5) 8 lci 1024
00:48:33: Cause 11, Diag 65 (Access barred/Facility code not allowed)
```

Configuring DDN or BFE X.25

- [Enabling DDN X.25, page 66](#)
- [Defining IP Precedence Handling, page 66](#)
- [Configuring Blacker Front End X.25, page 66](#)

Enabling DDN X.25

Both DCE and DTE operation causes the Cisco IOS software to specify the Standard Service facility in the Call Request packet, which notifies the PSNs to use Standard Service. To enable DDN X.25, use one of the following commands in interface configuration mode, as appropriate for your network:

Command	Purpose
Router(config-if)# encapsulation x25 ddn	Sets DDN X.25 DTE operation.
Router(config-if)# encapsulation x25 dce ddn	Sets DDN X.25 DCE operation.

Defining IP Precedence Handling

By default, the DDN X.25 software opens one VC for all types of service values. To enable the precedence-sensitivity feature, use the following command in interface configuration mode:

Command	Purpose
Router(config-if)# x25 ip-precedence	Allows a new VC based on the type of service (TOS) field.

Configuring Blacker Front End X.25

To set BFE encapsulation on the router attached to a BFE device, use the following command in interface configuration mode:

Command	Purpose
Router(config-if)# encapsulation x25 bfe	Sets BFE encapsulation on the router attached to a BFE device.

Configuring X.25 Remote Failure Detection

- [X.25 Remote Failure Detection with IP Static Routes](#), page 66
- [X.25 Remote Failure Detection and the Backup Interface](#), page 67
- [Verifying X.25 Remote Failure Detection](#), page 69

X.25 Remote Failure Detection with IP Static Routes

To configure X.25 remote failure detection with IP static routes, use the following commands beginning in global configuration mode:

SUMMARY STEPS

1. Router(config)# **interface** *number*
2. Router(config-if)# **encapsulation x25**
3. Router(config-if)# **x25 address** *x121-address*
4. Router(config-if)# **interface subinterface number point-to-point**
5. Router(config-subif)# **ip address** *address mask*
6. Router(config-subif)# **x25 map** *ipaddress x121address*
7. Router(config-subif)# **x25 retry interval seconds attempts count**
8. Router(config)# **ip route** *address mask serial subinterface number weight*
9. Router(config)# **ip route** *address mask serial nextsubinterface number weight*

DETAILED STEPS

	Command or Action	Purpose
Step 1	Router(config)# interface <i>number</i>	Enters specified interface configuration mode.
Step 2	Router(config-if)# encapsulation x25	Enables X.25 encapsulation on the interface.
Step 3	Router(config-if)# x25 address <i>x121-address</i>	Sets X.121 address of the network interface.
Step 4	Router(config-if)# interface subinterface number point-to-point	Enters specified subinterface and enables point-to-point for it.
Step 5	Router(config-subif)# ip address <i>address mask</i>	Creates IP address and mask for the subinterface.
Step 6	Router(config-subif)# x25 map <i>ipaddress x121address</i>	Maps IP address to an X.121 address.
Step 7	Router(config-subif)# x25 retry interval seconds attempts count	Enables the X.25 retry option on the subinterface.
Step 8	Router(config)# ip route <i>address mask serial subinterface number weight</i>	Configures static route from point-to-point interface specified to a destination.
Step 9	Router(config)# ip route <i>address mask serial nextsubinterface number weight</i>	Configures static route from next point-to-point interface specified for the same destination.

X.25 Remote Failure Detection and the Backup Interface

To configure X.25 remote failure detection and create a backup interface, use the following commands beginning in global configuration mode. Note that IP static routes need not be configured because this backup route is being only configured as a secondary route.

SUMMARY STEPS

1. Router(config)# **interface** *number*
2. Router(config-if)# **encapsulation x25**
3. Router(config-if)# **x25 address** *x121-address*
4. Router(config)# **interface subinterface number point-to-point**
5. Router(config-subif)# **ip address** *address mask*
6. Router(config-subif)# **x25 map** *ipaddress x121address*
7. Router(config-subif)# **x25 retry interval** *seconds attempts count*
8. Router(config-subif)# **backup interface serial** *number*
9. Router(config)# **interface** *number*
10. Router(config-if)# **encapsulation x25**
11. Router(config-if)# **x25 address** *x121-address*
12. Router(config-if)# **ip address** *address mask*
13. Router(config-if)# **x25 map** *ipaddress x121address*

DETAILED STEPS

	Command or Action	Purpose
Step 1	Router(config)# interface <i>number</i>	Enters specified interface configuration mode.
Step 2	Router(config-if)# encapsulation x25	Enables X.25 encapsulation on the interface.
Step 3	Router(config-if)# x25 address <i>x121-address</i>	Sets X.121 address of the network interface.
Step 4	Router(config)# interface subinterface number point-to-point	Enters specified subinterface and configures point-to-point for it.
Step 5	Router(config-subif)# ip address <i>address mask</i>	Creates IP address and mask for the subinterface.
Step 6	Router(config-subif)# x25 map <i>ipaddress x121address</i>	Maps IP address to an X.121 address.
Step 7	Router(config-subif)# x25 retry interval <i>seconds attempts count</i>	Enables the X.25 retry option on the subinterface.
Step 8	Router(config-subif)# backup interface serial <i>number</i>	Configures specified interface as the backup.
Step 9	Router(config)# interface <i>number</i>	Enters specified interface configuration mode to configure the backup.
Step 10	Router(config-if)# encapsulation x25	Enables X.25 encapsulation on the interface.
Step 11	Router(config-if)# x25 address <i>x121-address</i>	Sets X.121 address of the network interface.
Step 12	Router(config-if)# ip address <i>address mask</i>	Creates IP address and mask for the subinterface.
Step 13	Router(config-if)# x25 map <i>ipaddress x121address</i>	Maps IP address to an X.121 address.

Verifying X.25 Remote Failure Detection

SUMMARY STEPS

1. To verify X.25 remote failure detection, use the **show interfaces serial** command on the interface with the **x25 retry** command configured. The last line in the following output shows the X.25 retry mechanism currently in action on subinterface 1.1, which is currently down--as indicated by the "(retry in progress)" statement--and which has "tried" one out of its possible 100 retry attempts.
2. To verify which route is currently in use by IP, use the **show ip route** command.
3. The **debug x25 events** command can be also activated, so that you can see a call being attempted by the X.25 retry mechanism every configured interval.

DETAILED STEPS

- Step 1** To verify X.25 remote failure detection, use the **show interfaces serial** command on the interface with the **x25 retry** command configured. The last line in the following output shows the X.25 retry mechanism currently in action on subinterface 1.1, which is currently down--as indicated by the "(retry in progress)" statement--and which has "tried" one out of its possible 100 retry attempts.

Example:

```
Router# show interfaces serial1
Serial1 is up, line protocol is up
Hardware is QUICC Serial
MTU 1500 bytes, BW 1544 Kbit, DLY 20000 usec,
  reliability 255/255, txload 1/255, rxload 1/255
Encapsulation X25, loopback not set
X.25 DTE, address 11111, state R1, modulo 8, timer 0
  Defaults: idle VC timeout 0
    cisco encapsulation
      input/output window sizes 2/2, packet sizes 128/128
  Timers: T20 180, T21 200, T22 180, T23 180
  Channels: Incoming-only none, Two-way 1-1024, Outgoing-only none
  RESTARTs 2/0 CALLs 0+0/0+0/0+0 DIAGs 0/0
Interface Serial1.1:retry-interval 5, attempts 100, tried 1 (retry in progress)
```

- Step 2** To verify which route is currently in use by IP, use the **show ip route** command.
- Step 3** The **debug x25 events** command can be also activated, so that you can see a call being attempted by the X.25 retry mechanism every configured interval.

Creating X.29 Access Lists

- [Creating an X.29 Access List, page 69](#)
- [Applying an Access List to a Virtual Terminal Line, page 70](#)

Creating an X.29 Access List

To specify the access conditions, use the following command beginning in global configuration mode:

Command	Purpose
Router(config)# x29 access-list <i>access-list-number</i> {deny permit} <i>x121-address</i>	Restricts incoming and outgoing connections between a particular vty (into a Cisco access server) and the addresses in an access list.

Applying an Access List to a Virtual Terminal Line

To apply an access list to a virtual line, use the following command in line configuration mode:

Command	Purpose
Router(config)# access-class <i>access-list-number</i> in	Restricts incoming and outgoing connections between a particular vty (into a Cisco access server) and the addresses in an access list.

Creating an X.29 Profile Script

You can create an X.29 profile script for use by the **translate** command. When an X.25 connection is established, the protocol translator then acts as if an X.29 Set Parameter packet had been sent that contained the parameters and values set by this command.

To create an X.29 profile script, use the following command beginning in global configuration mode:

Command	Purpose
Router(config)# x29 profile {default name} <i>parameter : value</i> [<i>parameter : value</i>]	Creates an X.29 profile script.

For an example of a profile script, see the section [X.29 Profile Script Example](#), page 94 at the end of this chapter.

Monitoring and Maintaining LAPB and X.25

To monitor and maintain X.25 and LAPB, use any of the following commands in EXEC mode:

Command	Purpose
Router# clear x25 {serial <i>number</i> <i>cmns-interface mac-address</i> } [<i>vc-number</i>]	Clears an SVC, restarts an X.25 or CMNS service, or resets a PVC.
Router# clear xot remote <i>ip-address port local ip-address port</i>	Clears an XOT SVC or resets an XOT PVC.
Router# show cmns [<i>type number</i>]	Displays CMNS information.
Router# show interfaces serial <i>number</i>	Displays operation statistics for an interface.

Command	Purpose
Router# show llc2	Displays CMNS connections over LLC2.
Router# show x25 interface [<i>serial number</i> <i>cmns-interface</i>] mac <i>mac-address</i>	Displays information about VCs on an X.25 interface (a serial interface) or a CMNS interface (an Ethernet, Token Ring, or FDDI interface).
Router# show x25 map	Displays the protocol-to-X.121 address map.
Router# show x25 remote-red	Displays the one-to-one mapping of the IP addresses of the host and the IP addresses of the remote BFE device.
Router# show x25 route	Displays routes assigned by the x25 route command.
Router# show x25 services	Displays information about X.25 services.
Router# show x25 vc [<i>lcn</i>]	Displays details of active VCs.
Router# show x25 xot [<i>local ip-address</i> [<i>port port</i>]] [<i>remote ip-address</i> [<i>port port</i>]]	Displays information for all XOT VCs or, optionally, for VCs that match a specified set of criteria.

X.25 and LAPB Configuration Examples

- [Typical LAPB Configuration Example, page 72](#)
- [Transparent Bridging for Multiprotocol LAPB Encapsulation Example, page 72](#)
- [Typical X.25 Configuration Example, page 72](#)
- [VC Ranges Example, page 74](#)
- [X.25 Failover Example, page 74](#)
- [PVC Switching on the Same Router Example, page 74](#)
- [X.25 Route Address Pattern Matching Example, page 74](#)
- [X.25 Routing Examples, page 75](#)
- [PVC Used to Exchange IP Traffic Example, page 76](#)
- [Point-to-Point Subinterface Configuration Example, page 76](#)
- [Simple Switching of a PVC over XOT Example, page 77](#)
- [PVC Switching over XOT Example, page 77](#)
- [X.25 Load Balancing Examples, page 78](#)
- [X.25 Switching Between PVCs and SVCs Example, page 79](#)
- [Inserting and Removing X.121 Addresses As Calls Are Routed Example, page 80](#)
- [Forwarding Calls Using the continue Keyword Example, page 80](#)
- [DNS-Based X.25 Routing Example, page 82](#)
- [X.25overFrameRelayAnnexGExample, page 82](#)

- [CMNS Switching Example, page 83](#)
- [CMNS Switching over a PDN Example, page 84](#)
- [CMNS Switched over Leased Lines Example, page 85](#)
- [Configuring Local Acknowledgment Example, page 86](#)
- [Setting Asymmetrical Window and Packet Sizes Flow Control Never Example, page 86](#)
- [Configuring Flow Control Always Example, page 87](#)
- [X.25 CUGs Examples, page 88](#)
- [DDN X.25 Configuration Example, page 90](#)
- [Blacker Front End Example, page 91](#)
- [X.25 Ping Support over Multiple Lines Example, page 91](#)
- [Booting from a Network Server over X.25 Example, page 92](#)
- [X.25 Remote Failure Detection Examples, page 92](#)
- [X.29 Access List Example, page 93](#)
- [X.29 Profile Script Example, page 94](#)

Typical LAPB Configuration Example

In the following example, the frame size (N1), window size (k), and maximum retransmission (N2) parameters retain their default values. The **encapsulation** interface configuration command sets DCE operation to carry a single protocol, IP by default. The **lapb t1** interface configuration command sets the retransmission timer to 4,000 milliseconds (4 seconds) for a link with a long delay or slow connecting DTE device.

```
interface serial 3
 encapsulation lapb dce
 lapb t1 4000
```

Transparent Bridging for Multiprotocol LAPB Encapsulation Example

The following example configures transparent bridging for multiprotocol LAPB encapsulation:

```
no ip routing
!
interface Ethernet 1
 no ip address
 no mop enabled
 bridge-group 1
!
interface serial 0
 no ip address
 encapsulation lapb multi
 bridge-group 1
!
bridge 1 protocol ieee
```

Typical X.25 Configuration Example

The following example shows the complete configuration for a serial interface connected to a commercial X.25 PDN for routing the IP protocol. The IP subnetwork address 172.25.9.0 has been assigned for the X.25 network.

**Note**

When you are routing IP over X.25, you must treat the X.25 network as a single IP network or subnetwork. Map entries for routers that have addresses on subnetworks other than the one on which the IP address of the interface is stored are ignored by the routing software. Additionally, all routers using the subnet number must have map entries for all other routers. Moreover, using the broadcast option with dynamic routing can result in significantly larger traffic loads, requiring a larger hold queue, larger window sizes, or multiple VCs.

```

interface serial 2
 ip address 172.25.9.1 255.255.255.0
 !
 encapsulation X25
 !
 ! The "bandwidth" command is not part of the X.25
 ! configuration; it is especially important to understand that it does not
 ! have any connection with the X.25 entity of the same name.
 ! "bandwidth" commands are used by IP routing processes (currently only IGRP)
 ! to determine which lines are the best choices for traffic.
 ! Since the default is 1544 Kbaud, and X.25 service at that rate is not generally
 ! available, most X.25 interfaces that are being used with IGRP in a
 ! real environment will have "bandwidth" settings.
 !
 ! This is a 9.6 Kbaud line:
 !
 bandwidth 10
 ! You must specify an X.121 address to be assigned to the X.25 interface by the PDN.
 !
 x25 address 31370054065
 !
 ! The following Level 3 parameters have been set to match the network.
 ! You generally need to change some Level 3 parameters, most often
 ! those listed below. You might not need to change any Level 2
 ! parameters, however.
 !
 x25 htc 32
 !
 ! These Level 3 parameters are default flow control values; they need to
 ! match the PDN defaults. The values used by an SVC are negotiable on a per-call basis:
 !
 x25 win 7
 x25 wout 7
 x25 ips 512
 x25 ops 512
 !
 !
 ! The following commands configure the default behavior for our encapsulation
 ! SVCs
 !
 x25 idle 5
 x25 nvc 2
 !
 ! The following commands configure the X.25 map. If you want to exchange
 ! routing updates with any of the routers, they would need
 ! "broadcast" flags.
 ! If the X.25 network is the only path to the routers, static routes are
 ! generally used to save on packet charges. If there is a redundant
 ! path, it might be desirable to run a dynamic routing protocol.
 !
 x25 map IP 172.25.9.3 31370019134 ACCEPT-REVERSE
 ! ACCEPT-REVERSE allows collect calls
 x25 map IP 172.25.9.2 31370053087
 !
 ! If the PDN cannot handle fast back-to-back frames, use the
 ! "transmitter-delay" command to slow down the interface.
 !
 transmitter-delay 1000

```

VC Ranges Example

The following example sets the VC ranges of 5 to 20 for incoming calls only (from the DCE to the DTE) and 25 to 1024 for either incoming or outgoing calls. It also specifies that no VCs are reserved for outgoing calls (from the DTE to the DCE). Up to four permanent VCs can be defined on VCs 1 through 4.

```
x25 lic 5
x25 hic 20
x25 ltc 25
```

X.25 Failover Example

In the following example, X.25 failover is configured on a network that is also configured for Annex G. If data-link connection identifier (DLCI) 13 or DLCI 14 on serial interface 1/0 goes down, dialer interface 1 will serve as the secondary interface. After DLCI 13 or 14 comes back up and remains up for 20 seconds, dialer interface 1 will reset, sending all calls back to the primary interface.

```
interface serial1/0
 encapsulation frame-relay
 frame-relay interface-dlci 13
 x25-profile frame1
 exit
 frame-relay interface-dlci 14
 x25-profile frame1
 exit
!
interface dialer1
 encapsulation x25
 exit
x25 route ^1234 interface serial1/0 dlci 13
x25 route ^1234 interface serial1/0 dlci 14
x25 route ^1234 interface dialer1
!
x25 profile frame1 dte
 x25 fail-over 20 interface dialer1
 exit
!
```

PVC Switching on the Same Router Example

In the following example, a PVC is connected between two serial interfaces on the same router. In this type of interconnection configuration, the destination interface must be specified along with the PVC number on that interface. To make a working PVC connection, two commands must be specified, each pointing to the other.

```
interface serial 0
 encapsulation x25
 x25 ltc 5
 x25 pvc 1 interface serial 1 pvc 4
!
interface serial 1
 encapsulation x25
 x25 ltc 5
 x25 pvc 4 interface serial 0 pvc 1
```

X.25 Route Address Pattern Matching Example

The following example shows how to route X.25 calls with addresses whose first four Data Network Identification Code (DNIC) digits are 1111 to interface serial 3. This example also shows how to change

the DNIC field to 2222 in the addresses presented to equipment connected to that interface. The `\1` in the rewrite pattern indicates the portion of the original address matched by the digits following the 1111 DNIC.

```
x25 route ^1111(.*) substitute-dest 2222\1 interface serial 3
```

The figure below shows a more contrived command intended to illustrate the power of the rewriting scheme.

Figure 9 X.25 Route Address Pattern Matching Example

```
x25 route ^(...)..(..)..(..)..$ substitute-dest \2\4\3\1 interface serial 0
```

The command in the figure above causes all X.25 calls with 14-digit called addresses to be routed through interface serial 0. The incoming DNIC field is moved to the end of the address. The fifth, sixth, ninth, and tenth digits are deleted, and the thirteenth and fourteenth are moved before the eleventh and twelfth.

X.25 Routing Examples

The following examples illustrate how to enable the X.25 switch service and how to configure a router on a Tymnet/PAD switch to accept and forward calls.

The first example shows enabling X.25 switching and entering routes in the X.25 routing table:

```
! Enable X.25 forwarding
x25 routing
! Enter routes into the table. Without a positional parameter, entries
! are appended to the end of the table
x25 route ^100$ interface serial 0
x25 route 100 cud ^pad$ interface serial 2
x25 route 100 interface serial 1
x25 route ^3306 interface serial 3
x25 route .* ip 10.2.0.2
```

The routing table forwards calls for X.121 address 100 out interface serial 0. Otherwise, calls are forwarded onto serial 1 if the X.121 address contains 100 anywhere within it and contains no call user data (CUD), or if the CUD is not the string "pad." If the X.121 address contains the digits 100 and the CUD is the string "pad," the call is forwarded onto serial 2. All X.121 addresses that do not match the first three routes are checked for a DNIC of 3306 as the first four digits. If they do match, they are forwarded over serial 3. All other X.121 addresses will match the fifth entry, which is a match-all pattern and will have a TCP connection established to the IP address 10.2.0.2. The router at 10.2.0.2 will then handle the call according to its configuration.

This second example configures a router that sits on a Tymnet/PAD switch to accept calls and have them forwarded to a DEC VAX system. This feature permits running an X.25 network over a generalized existing IP network, thereby making another physical line for one protocol unnecessary. The router positioned next to the DEC VAX system is configured with X.25 routes, as follows:

```
x25 route vax-x121-address interface serial 0
x25 route .* ip cisco-on-tymnet-ipaddress
```

These commands route all calls to the DEC VAX X.121 address out to serial 0, where the VAX is connected running PSI. All other X.121 addresses are forwarded to the "cisco-on-tymnet" address through

its IP address. As a result, all outgoing calls from the VAX are sent to "cisco-on-tymnet" for further processing.

On the router named "cisco-on-tymnet", you enter these commands:

```
x25 route vax-x121-address ip cisco-on-vax
x25 route .* interface serial 0
```

These commands force all calls with the VAX X.121 address to be sent to the router that has the VAX connected to it. All other calls with X.121 addresses are forwarded out to Tymnet. If Tymnet can route them, a Call Accepted packet is returned, and everything proceeds normally. If Tymnet cannot handle the calls, it clears each call and the Clear Request packet is forwarded back toward the VAX.

PVC Used to Exchange IP Traffic Example

The following example, illustrated in the figure below, demonstrates how to use the PVC to exchange IP traffic between router X and router Y.

Figure 10 Establishing an IP Encapsulation PVC Through an X.25 Network



Configuration for Router X

```
interface serial 2
 ip address 172.20.1.3 255.255.255.0
 x25 pvc 4 ip 172.20.1.4
```

Configuration for Router Y

```
interface serial 3
 ip address 172.20.1.4 255.255.255.0
 x25 pvc 3 ip 172.20.1.3
```

In this example, the PDN has established a PVC through its network, connecting PVC number 3 of access point A to PVC number 4 of access point B. On router X, a connection is established between router X and router Y's IP address, 172.20.1.4. On router Y, a connection is established between router Y and router X's IP address, 172.20.1.3.

Point-to-Point Subinterface Configuration Example

The following example creates a point-to-point subinterface, maps IP and AppleTalk to a remote host, and creates an encapsulating PVC for DECnet to the same remote host, identified by the X.121 address in the commands:

```
interface Serial0.1 point-to-point
 x25 map ip 172.20.170.90 170090 broadcast
 x25 map appletalk 4.50 170090 broadcast
 x25 pvc 1 decnet 1.2 170090 broadcast
```

Simple Switching of a PVC over XOT Example

In the following simple example, a connection is established between two PVCs across a LAN. Because the connection is remote (across the LAN), the XOT service is used. This example establishes a PVC between router X, serial 0, PVC 1 and router Y, serial 1, PVC 2. Keepalives are enabled to maintain connection notification. The figure below provides a visual representation of the configuration.

Figure 11 X.25 PVC Connection



Configuration for Router X

```
service tcp-keepalives-in
service tcp-keepalives-out
interface serial 0
  x25 pvc 1 xot 172.20.1.2 interface serial 1 pvc 2
```

Configuration for Router Y

```
service tcp-keepalives-in
service tcp-keepalives-out
interface serial 1
  x25 pvc 2 xot 172.20.1.1 interface serial 0 pvc 1
```

PVC Switching over XOT Example

In the more complex example shown in the figure below, the connection between points A and B is switched, and the connections between point C and points A and B are made using XOT. Keepalives are enabled to maintain connection notification.

Figure 12 PVC Switching over XOT

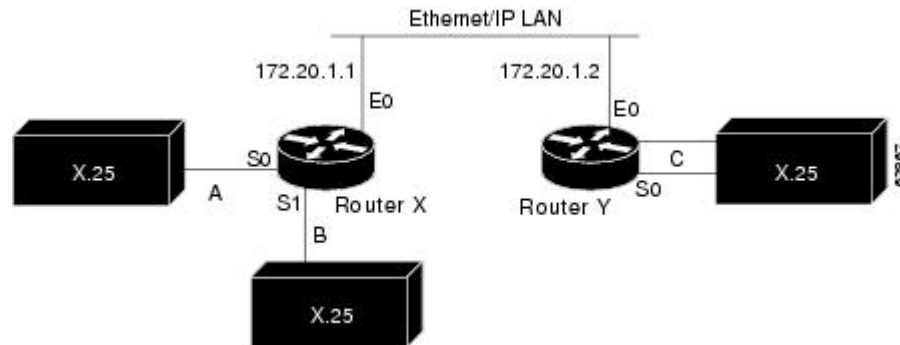

Configuration for Router X

```

service tcp-keepalives-in
service tcp-keepalives-out
interface ethernet 0
 ip address 172.20.1.1 255.255.255.0
!
interface serial 0
 x25 ltc 5
 x25 pvc 1 interface serial 1 pvc 1
 x25 pvc 2 xot 172.20.1.2 interface serial 0 pvc 1
!
interface serial 1
 x25 ltc 5
 x25 pvc 1 interface serial 0 pvc 1
 x25 pvc 2 xot 172.20.1.2 interface serial 0 pvc 2

```

Configuration for Router Y

```

service tcp-keepalives-in
service tcp-keepalives-out
interface ethernet 0
 ip address 172.20.1.2 255.255.255.0
!
interface serial 0
 x25 ltc 5
 x25 pvc 1 xot 172.20.1.1 interface serial 0 pvc 2
 x25 pvc 2 xot 172.20.1.1 interface serial 1 pvc 2

```

X.25 Load Balancing Examples

For examples of X.25 load balancing, see the following sections:

- [X.25 Load Balancing Using VC-Count Distribution Method Example, page 78](#)
- [X.25 Load Balancing with Multiple Hunt Groups Example, page 78](#)

X.25 Load Balancing Using VC-Count Distribution Method Example

In the following example, the vc-count distribution method is used on two serial interfaces that have different numbers of VCs. Assuming that no sessions are being terminated at this time, the first 450 calls will be sent to Serial1, and subsequent calls will alternate between Serial0 and Serial1 until the interfaces are full.

```

!
interface serial0
 description 56k link supporting 50 virtual circuits
 x25 htc 50
!
interface serial1
 description T1 line supporting 500 virtual circuits
 x25 htc 500
!
x25 hunt-group hg-vc vc-count
 interface serial0
 interface serial1
!

```

X.25 Load Balancing with Multiple Hunt Groups Example

The following example enables X.25 encapsulation on relevant serial interfaces and configures serial interfaces 1 and 2 to participate in X.25 hunt group "HG1," and serial interfaces 0 and 3 to participate in X.25 hunt group "HG2." Serial interfaces 1 and 2 and XOT IP addresses 172.17.125.54 and 172.17.125.34 are

then associated with hunt group "HG1" (with rotary distribution assigned); and serial interfaces 0 and 3 are associated with hunt group "HG2" (with vc-count distribution assigned). These hunt groups are then added to the routing table, where X.25 route 1111 will use "HG1" and X.25 route 1112 will use "HG2".

```
x25 routing
interface serial 0
  encapsulation x25
interface serial 1
  encapsulation x25
interface serial 2
  encapsulation x25
interface serial 3
  encapsulation x25
!
x25 hunt-group HG1 rotary
  interface serial 1
  interface serial 2
  xot 172.17.125.54
  xot 172.17.125.34
  exit
!
x25 hunt-group HG2 vc-count
  interface serial0
  interface serial3
  exit
!
x25 route 1111 hunt-group HG1
x25 route 1112 hunt-group HG2
```

X.25 Switching Between PVCs and SVCs Example

The following example allows X.25 switching between a PVC on the first interface and an SVC on the second interface. X.25 traffic arriving on PVC 20 on serial interface 0 will cause a call to be placed to 000000160100, if one does not already exist.

```
x25 routing
interface serial0
  encapsulation x25
  x25 address 000000180100
  x25 ltc 128
  x25 pvc 20 svc 000000160100 packetsize 128 128 windowsize 2 2
interface serial2
  encapsulation x25 dce
  x25 route ^000000160100$ interface Serial2
  x25 route ^000000180100$ interface Serial0
```

The **x25 route** command adds the two X.121 addresses to the X.25 routing table. Data traffic received on PVC 20 on serial interface 0 will cause a call to be placed with a Called (destination) Address of 000000160100; this call will be routed to serial interface 2. Alternatively, an X.25 call received with a Called Address of 000000180100 and a Calling Address of 000000160100 will be associated with PVC 20 on serial interface 0. In either case, subsequent X.25 traffic on either the SVC or the PVC will be forwarded to the other circuit. Because no idle timeout has been specified for the interface or for the circuit, the router will not clear the call.

Inserting and Removing X.121 Addresses As Calls Are Routed Example

The following example shows insertions and removals in the X.121 address as calls from the X.25 network get routed to X.25 devices. The figure below shows the topology for this example.

Figure 13 Typical X.25 Network Configuration

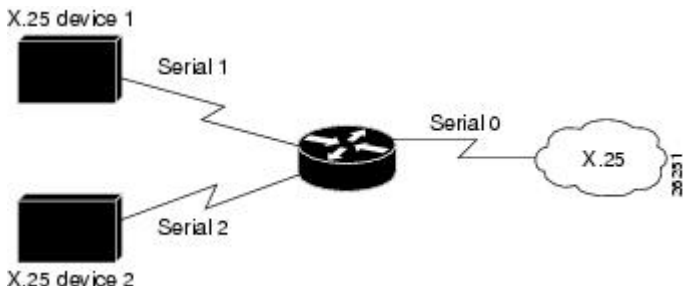

Example Configuration

```
x25 route ^2(.*) input-interface serial1 substitute-dest \1 interface serial2
x25 route input-interface serial2 source .* substitute-source 2\0 interface serial0
```

For a call coming from interface serial 1 with a called address starting with 2, the 2 is stripped off the called address and the call forwarded to serial interface 2.

For a call coming from interface serial 2 with any calling address, a 2 will be inserted to its calling address and the call forwarded to serial interface 0.

Forwarding Calls Using the continue Keyword Example

This section provides two examples of the same configuration. Both examples show how to forward calls among a number of local X.25 devices; however, the second example shows how the **continue** keyword reduces the number of routing statements. (Keep in mind that the **continue** keyword is most useful when you will be switching calls among four or more routes.)

The figure below illustrates the network topology for both examples.

Figure 14 X.25 Network with Multiple Interfaces

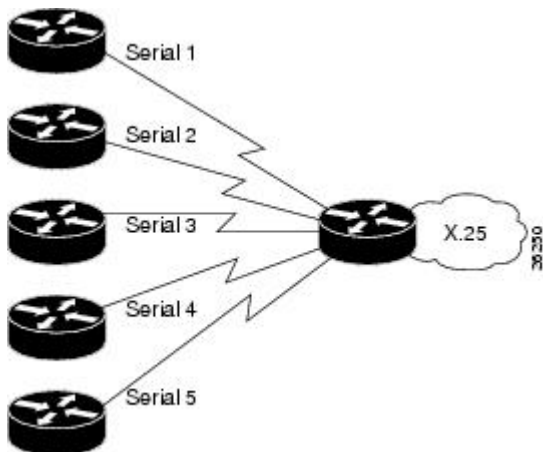

- [X.25 Routing Statements Before continue Keyword, page 81](#)
- [Same X.25 Network Configuration with continue Keyword, page 81](#)

X.25 Routing Statements Before continue Keyword

The following example shows how to forward calls among a number of local X.25 devices without using the **continue** keyword:

```
x25 route ^02 input-interface serial 1 substitute-source 01\0 substitute-dest \1
interface serial 2
x25 route ^03 input-interface serial 1 substitute-source 01\0 substitute-dest \1
interface serial 3
x25 route ^04 input-interface serial 1 substitute-source 01\0 substitute-dest \1
interface serial 4
x25 route ^05 input-interface serial 1 substitute-source 01\0 substitute-dest \1
interface serial 5
!
x25 route ^01 input-interface serial 2 substitute-source 02\0 substitute-dest \1
interface serial 1
x25 route ^03 input-interface serial 2 substitute-source 02\0 substitute-dest \1
interface serial 3
x25 route ^04 input-interface serial 2 substitute-source 02\0 substitute-dest \1
interface serial 4
x25 route ^05 input-interface serial 2 substitute-source 02\0 substitute-dest \1
interface serial 5
!
x25 route ^02 input-interface serial 3 substitute-source 03\0 substitute-dest \1
interface serial 2
x25 route ^01 input-interface serial 3 substitute-source 03\0 substitute-dest \1
interface serial 1
x25 route ^04 input-interface serial 3 substitute-source 03\0 substitute-dest \1
interface serial 4
x25 route ^05 input-interface serial 3 substitute-source 03\0 substitute-dest \1
interface serial 5
!
x25 route ^02 input-interface serial 4 substitute-source 04\0 substitute-dest \1
interface serial 2
x25 route ^03 input-interface serial 4 substitute-source 04\0 substitute-dest \1
interface serial 3
x25 route ^01 input-interface serial 4 substitute-source 04\0 substitute-dest \1
interface serial 1
x25 route ^05 input-interface serial 4 substitute-source 04\0 substitute-dest \1
interface serial 5
!
x25 route ^02 input-interface serial 5 substitute-source 05\0 substitute-dest \1
interface serial 2
x25 route ^03 input-interface serial 5 substitute-source 05\0 substitute-dest \1
interface serial 3
x25 route ^04 input-interface serial 5 substitute-source 05\0 substitute-dest \1
interface serial 4
x25 route ^01 input-interface serial 5 substitute-source 05\0 substitute-dest \1
interface serial 1
```

Same X.25 Network Configuration with continue Keyword

The following example shows how to forward calls among a number of local X.25 devices using the **continue** keyword:

```
x25 route input-interface serial 1 source .* substitute-source 01\0 continue
x25 route input-interface serial 2 source .* substitute-source 02\0 continue
x25 route input-interface serial 3 source .* substitute-source 03\0 continue
x25 route input-interface serial 4 source .* substitute-source 04\0 continue
x25 route input-interface serial 5 source .* substitute-source 05\0 continue
x25 route ^01(.) substitute-dest \1 interface serial 1
x25 route ^02(.) substitute-dest \1 interface serial 2
x25 route ^03(.) substitute-dest \1 interface serial 3
```

```
x25 route ^04(.*) substitute-dest \1 interface serial 4
x25 route ^05(.*) substitute-dest \1 interface serial 5
```

DNS-Based X.25 Routing Example

The following example shows XOT switch configuration for XOT switching via the DNS:

```
Router(config)#
ip tcp synwait-time 5
Router(config)#
ip name-server 10.1.1.40
Router(config)#
x25 routing
Router(config)#
service pad to-xot
Router(config)#
service pad from-xot
Router(config)#
ip domain-name home.com
Router(config)#
ip domain-list home.com
Router(config)#
ip domain-lookup
Router(config)#
interface Ethernet1
Router(config-if)#
ip address 10.1.1.2 255.255.255.0
Router(config-if)#
exit
Router(config)#
interface Serial0
Router(config-if)#
encapsulation x25 dce
Router(config-if)#
exit
Router(config)#
x25 route 444 xot dns \0
Router(config)#
x25 route 555 xot dns \0
```

X.25overFrameRelayAnnexGExample

The following example configures X.25 profile "NetworkNodeA" (using the X.25 commands **x25 htc**, **x25 idle**, **x25 accept-reverse** and **x25 modulo**) on DLCI interfaces 20 and 30; and X.25 profile "NetworkNodeB" (using the X.25 command **x25 address**) on DLCI interface 40; all on serial interface 1. The example shows the final step of assigning your X.25 profile to the DLCI interface by using the **frame-relay interface-dlci** command, and then assigning X.25 routes to DLCIs 20, 30, and 40 using the **x25 route** command.

The new **x25 profile** command mode (config-x25) can be seen in this example. This mode is used for configuring the parameters of your X.25 profile. For a complete description of this command and mode, refer to the **x25 profile** command section in the chapter "X.25 and LAPB Commands" in the *Cisco IOS Wide-Area Networking Command Reference*.

This example assumes that you already have Frame Relay enabled on your router.

```
R
outer(config)#
x25 routing
Router(config)#
x25 profile NetworkNodeA dce
Router(config-x25)#
x25 htc 128
Router(config-x25)#
x25 idle 5
```

```

Router(config-x25)#
x25 accept-reverse
Router(config-x25)#
x25 modulo 128
Router(config-x25)#
end
Router(config)#
x25 profile NetworkNodeB dce
Router(config-x25)#
x25 address 1111
Router(config-x25)#
end
Router(config)#
interface serial1
Router(config-if)#
  encapsulation frame-relay

Router(config-if)#
frame-relay interface-dlci 20
Router(config-fr-dlci)#
x25-profile NetworkNodeA
Router(config-fr-dlci)#
end
Router(config)#
interface serial1
Router(config-if)#
frame-relay interface-dlci 30
Router(config-fr-dlci)#
x25-profile NetworkNodeA
Router(config-fr-dlci)#
end
Router(config)#
interface serial1
Router(config-if)#
frame-relay interface-dlci 40
Router(config-fr-dlci)#
x25-profile NetworkNodeB
Router(config-fr-dlci)#
end
Router(config)#
x25 route 2000 interface serial1 dlci 20
Router(config)#
x25 route 3000 interface serial1 dlci 30
Router(config)#
x25 route 4000 interface serial1 dlci 40

```

CMNS Switching Example

The following example illustrates enabling CMNS and configuring X.25 routes to the available CMNS host and the PDN connectivity:

```

interface ethernet 0
  cmns enable
  !
interface serial 0
  encapsulation x25
  !
interface serial 1
  encapsulation x25
  !
x25 route dest-ext ^38.8261.1000.0150.1000.17 interface Ethernet0 mac 0000.0c00.ff89
! Above maps NSAP to MAC-address on Ethernet0
!
x25 route dest-ext ^38.8261.1000.0150.1000.18 substitute-dest 3110451 interface Serial0
! Above maps NSAP to X.121-address on Serial0 assuming the link is over a PDN
!
x25 route dest-ext ^38.8261.1000.0150.1000.20 interface Serial1
! Above specifies cmns support for Serial1
! assuming that the link is over a leased line

```

CMNS Switching over a PDN Example

The following example depicts switching CMNS over a packet-switched PDN. The figure below illustrates the general network topology for a CMNS switching application where calls are being made between resources on opposite sides of a remote link to Host A (on an Ethernet) and Host B (on a Token Ring), with a PDN providing the connection.

Figure 15 Example Network Topology for Switching CMNS over a PDN

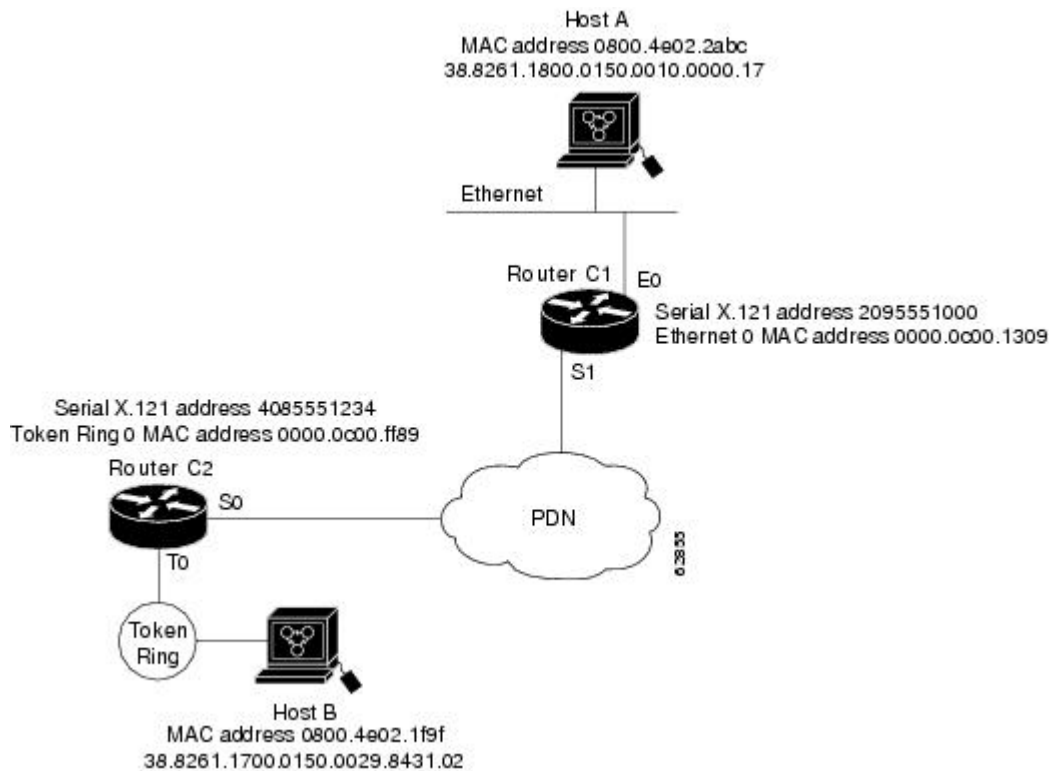

The following configuration listing allows resources on either side of the PDN to call host A or host B. This configuration allows traffic intended for the remote NSAP address specified in the **x25 route** commands (for the serial ports) to be switched through the serial interface for which CMNS is configured.

Configuration for Router C2

```
interface token 0
  cmns enable
  !
interface serial 0
  encapsulation x25
  x25 address 4085551234
  !
x25 route dest-ext ^38.8261.17 interface Token0 mac 0800.4e02.1f9f
  !
! The line above specifies that any traffic from any other interface
! intended for any NSAP address with NSAP prefix 38.8261.17 will be
! switched to MAC address 0800.4e02.1f9f through Token Ring 0
!
x25 route dest-ext ^38.8261.18 substitute-dest 2095551000 interface Serial0
  !
```

```
! The line above specifies that traffic from any other interface
! on Cisco Router C2 that is intended for any NSAP address with
! NSAP-prefix 38.8261.18 will be switched to
! X.121 address 2095551000 through Serial 0
```

Configuration for Router C1

```
interface ethernet 0
  cmns enable
!
interface serial 1
  encapsulation x25
  x25 address 2095551000
!
x25 route dest-ext ^38.8261.18 interface Ethernet0 mac 0800.4e02.2abc
!
! The line above specifies that any traffic from any other
! interface intended for any NSAP address with NSAP 38.8261.18
! will be switched to MAC address 0800.4e02.2abc through Ethernet 0
!
x25 route dest-ext ^38.8261.17 substitute-dest 4085551234 interface Serial1
!
! The line above specifies that traffic from any other interface
! on Cisco Router C1 that is intended for any NSAP address with
! NSAP-prefix 38.8261.17 will be switched to X.121 address
! 4085551234 through Serial 1
```

CMNS Switched over Leased Lines Example

The following example illustrates switching CMNS over a leased line. The figure below illustrates the general network topology for a CMNS switching application where calls are being made by resources on the opposite sides of a remote link to host C (on an Ethernet) and host B (on a Token Ring), with a dedicated leased line providing the connection.

The following configuration listing allows resources on either side of the leased line to call host C or host B. This configuration allows traffic intended for the remote NSAP address specified in the **x25 route** commands (for the serial ports) to be switched through the serial interface for which CMNS is configured.

Figure 16 Example Network Topology for Switching CMNS over a Leased Line

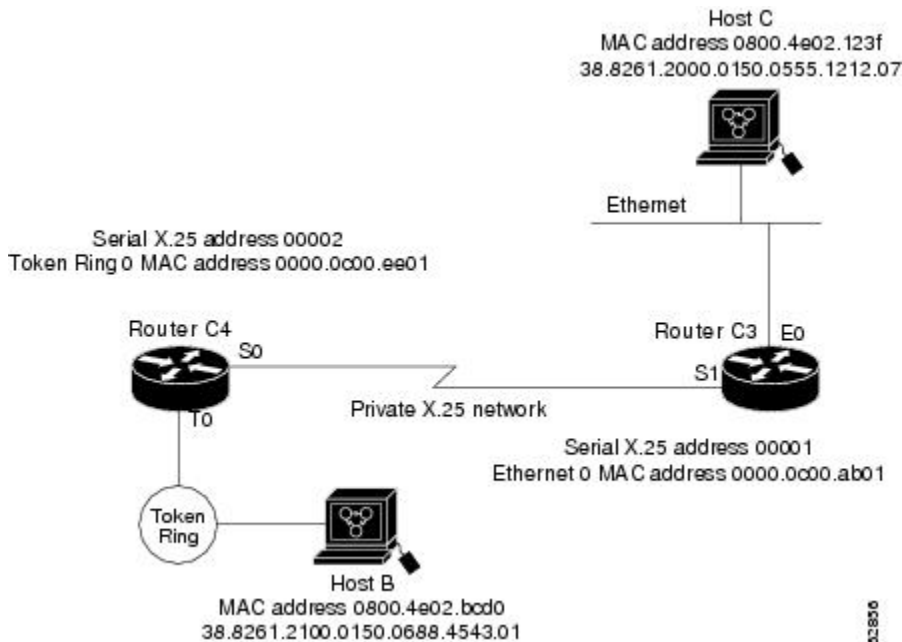

A key difference for this configuration compared with the previous example is that with no PDN, the substitution of the destination X.121 address in the **x25 route** command is not necessary. The specification of an X.25 address also is not needed, but it is included for symmetry with the previous example.

Configuration for Router C4

```
interface token 0
  cmns enable
!
interface serial 0
  encapsulation x25
  x25 address 4085551234
!
x25 route dest-ext ^38.8261.17 interface Token0 mac 0800.4e02.1f9f
!
! The line above specifies that any traffic from any other interface
! intended for any NSAP address with NSAP prefix 38.8261.17 will be
! switched to MAC address 0800.4e02.1f9f through Token Ring 0
!
x25 route dest-ext ^38.8261.18 interface Serial0
!
! The line above specifies that traffic from any other interface
! on Cisco Router C2 that is intended for any NSAP address with
! NSAP-prefix 38.8261.18 will be switched to
! X.121 address 2095551000 through Serial 0
```

Configuration for Router C3

```
interface ethernet 0
  cmns enable
!
interface serial 1
  encapsulation x25
  x25 address 2095551000
!
x25 route dest-ext ^38.8261.18 interface Ethernet0 mac 0800.4e02.2abc
!
! The line above specifies that any traffic from any other
! interface intended for any NSAP address with NSAP 38.8261.18
! will be switched to MAC address 0800.4e02.2abc through Ethernet 0
!
x25 route dest-ext ^38.8261.17 interface Serial1
!
! The line above specifies that traffic from any other interface
! on Cisco Router C1 that is intended for any NSAP address with
! NSAP-prefix 38.8261.17 will be switched to X.121 address
! 4085551234 through Serial 1
```

Configuring Local Acknowledgment Example

The following example shows X.25 local acknowledgment being configured on the router:

```
Router(config)# x25 routing acknowledge local
```

Setting Asymmetrical Window and Packet Sizes Flow Control Never Example

The following example shows asymmetrical window and packet sizes being set on the router on serial interfaces 0 and 1, with local acknowledgment enabled globally, and flow control disabled on both interfaces to allow asymmetrical flow control to occur:

```
Router(config)#
```

```

interface serial0
Router(config-if)#
x25 win 2
Router(config-if)#
x25 wout 3
Router(config-if)#
x25 ips 256
Router(config-if)#
x25 ops 512
Router(config-if)#
x25 ops 512
Router(config-if)#
exit
Router(config)#
interface serial1
Router(config-if)#
x25 win 4
Router(config-if)#
x25 wout 5
Router(config-if)#
x25 ips 128
Router(config-if)#
x25 ops 512
Router(config-if)#
exit
Router(config)#
x25 routing acknowledge local
Router(config)#
interface serial 0
Router(config-if)#
encapsulation x25 dte
Router(config-if)#
x25 subscribe flow-control never
Router(config-if)#
exit
Router(config)#
interface serial 1
Router(config-if)#
encapsulation x25 dte
Router(config-if)#
x25 subscribe flow-control never

```

Configuring Flow Control Always Example

The following example shows X.25 routing with local acknowledgment being enabled globally and flow control negotiation being enabled on serial interface 1/4. Window size ranges are set at a permitted rate of 1 (minimum) and 7 (maximum) and target rate of 2 (minimum) and 4 (maximum).

Packet size ranges are set at a permitted rate of 64 (minimum) and 1024 (maximum), and target rate of 128 (minimum) and 1024 (maximum).

```

R
outer(config)#
x25 routing acknowledge local
Router(config)#
  interface serial 1/4
Router(config-if)#
encapsulation x25 dte
Router(config-if)#
x25 subscribe flow-control always
Router(config-if)#
x25 subscribe window-size permit 1 7 target 2 4
Router(config-if)#
x25 subscribe packet-size permit 64 1024 target 128 1024

```

You do not have to configure window and packet size ranges because their default settings are appropriate for most configurations. The following example shows X.25 routing with local acknowledgment being

enabled globally and flow control negotiation being enabled on serial interface 1/4 with default window and packet size settings:

```
Router(config)#
interface serial 1/4
Router(config-if)#
encapsulation x25 dte
Router(config-if)#
x25 subscribe flow-control always
```

X.25 CUGs Examples

- [X.25 CUG Service and Access with CUG Properties Example, page 88](#)
- [POP with No CUG Access Example, page 88](#)
- [POP with Access Restricted to One CUG Example, page 89](#)
- [POPwithMultipleCUGsandNoPublicAccessExample, page 89](#)
- [POP with Multiple CUGs and Public Access Example, page 89](#)
- [CUG Selection Facility Suppression for the Preferential CUG Example, page 90](#)
- [CUG Selection Facility Suppression for All CUGs Example, page 90](#)

X.25 CUG Service and Access with CUG Properties Example

In the following example, X.25 CUG service is being subscribed to on serial 0, which then permits the subscription to local CUGs (5000, 100, 200, and 300). Subscription to local CUGs cannot be achieved without subscription to X.25 CUG service (although this occurs automatically--with CUG service default settings of no incoming and no outgoing access--the first time you subscribe to a specific CUG using the **x25 subscribe local-cug** command).

Local CUG 5000 has been designated as the preferential CUG, which means that it will be used when a call with no CUG membership selection is made. These local CUGs all belong to different network identifiers (IDs) (local 5000 = network 55; local 100 = network 11; local 200 = network 22; local 300 = network 33), but they could also subscribe to the same network ID if desired.

```
Router(config)#
interface serial0
Router(config-if)#
encapsulation x25 dce
Router(config-if)#
x25 subscribe cug-service incoming-access outgoing-access
Router(config-if)#
x25 subscribe local-cug 5000 network-cug 55 preferential
Router(config-if)#
x25 subscribe local-cug 100 network-cug 11
Router(config-if)#
x25 subscribe local-cug 200 network-cug 22
Router(config-if)#
x25 subscribe local-cug 300 network-cug 33
```

POP with No CUG Access Example

In the following example, serial interface 0 is being configured as a POP for a user that has no access to any of the CUGs in the network, but full public access (incoming and outgoing access)--the least restrictive setting:

```
Router(config)#
interface serial0
```



```
Router(config-if)#
encapsulation x25 dce
Router(config-if)#
x25 subscribe cug-service incoming-access outgoing-access
```

POP with Access Restricted to One CUG Example

In the following example, serial interface 0 is configured as a POP with access only to members of its own CUG and no public access. The POP is being configured for CUG service security using the most restrictive settings (the default) of the **x25 subscribe cug-service** command--no incoming and no outgoing access permitted. Local CUG 5000, which is associated with network 55, is being subscribed to this POP.

An outgoing call from the DTE may select local CUG 5000 or not. Because there is only one CUG subscribed to, its use is implicit. CUG 5000 will always select its related network CUG 55. An outgoing call that specifies a different local CUG will be refused. An incoming call must specify network CUG 55; otherwise the call will be refused.

```
Router(config)#
interface serial0
Router(config-if)#
encapsulation x25 dce
Router(config-if)#
x25 subscribe cug-service
Router(config-if)#
x25 subscribe local-cug 5000 network-cug 55
```

POP with Multiple CUGs and No Public Access Example

In the following example, serial interface 0 is being configured as a POP with access to members of several CUGs, using the most restrictive settings (the default) of the **x25 subscribe cug-service** command--no incoming and no outgoing access permitted. Local CUGs (5000, 100, 200, and 300) are then subscribed to this POP. Local CUG 5000 has been designated as the preferential CUG, which means that it will be used when a call with no CUG membership selection was made.

These local CUGs all belong to different networks (local 5000 = network 55; local 100 = network 11; local 200 = network 22; local 300 = network 33), but they could also subscribe to the same network if desired.

An outgoing call from the DTE may select any of the local CUGs (5000, 100, 200, and 300) or not. Because there is a preferential CUG (5000), its use will be implicit when no CUG is specified. The related network CUG (55) will be selected when switched to an intranetwork connection. A call specifying a different local CUG will be refused. An incoming call must select one of the network CUGs (55, 11, 22, or 33); otherwise the call will be refused.

```
Router(config)#
interface serial0
Router(config-if)#
encapsulation x25 dce
Router(config-if)#
x25 subscribe cug-service
Router(config-if)#
x25 subscribe local-cug 5000 network-cug 55 preferential
Router(config-if)#
x25 subscribe local-cug 100 network-cug 11
Router(config-if)#
x25 subscribe local-cug 200 network-cug 22
Router(config-if)#
x25 subscribe local-cug 300 network-cug 33
```

POP with Multiple CUGs and Public Access Example

In the following example, serial interface 0 is being configured as a POP with public access to members of several CUGs and the means to originate and receive calls from the open network (that is, to or from users that do not subscribe to one of the CUGs to which this POP subscribes).

An outgoing call from the DTE may select any of the local CUGs (1, 2, 3, or 4) or not. When no CUG is selected, it is assumed that the call is intended for the open network. When a CUG is selected, the related network CUG will be selected when the call is switched to an intranetwork connection. The call will be refused if it specifies a different local CUG from the one to which the POP is subscribed.

An incoming call to the DTE from an intra network connection may select related network CUGs (101, 202, 303, or 404) or no CUG. If no CUG is selected, the call is accepted as coming from the open network. A call that requires access to a different CUG will be refused.

```
Router(config)#
interface serial0
Router(config-if)#
encapsulation x25 dce
Router(config-if)#
x25 subscribe cug-service incoming-access outgoing-access
Router(config-if)#
x25 subscribe local-cug 1 network-cug 101
Router(config-if)#
x25 subscribe local-cug 2 network-cug 202
Router(config-if)#
x25 subscribe local-cug 3 network-cug 303
Router(config-if)#
x25 subscribe local-cug 4 network-cug 404
```

CUG Selection Facility Suppression for the Preferential CUG Example

In the following example, CUG selection facility suppression is configured for the preferential CUG only on serial interface 0:

```
interface serial0
encapsulation x25 dce
x25 subscribe cug-service suppress preferential
x25 subscribe local-cug 0 network-cug 10 preferential
x25 subscribe local-cug 50 network-cug 500
```

CUG Selection Facility Suppression for All CUGs Example

In the following example, CUG selection facility suppression and incoming access are configured for all CUGs, including the preferential CUG on the X.25 profile:

```
x25 profile CUG-SUPRS-ALL dce
x25 subscribe cug-service incoming-access suppress all
x25 subscribe local-cug 0 network-cug 10 preferential
x25 subscribe local-cug 20 network-cug 202
x25 subscribe local-cug 40 network-cug 40
```

DDN X.25 Configuration Example

The following example illustrates how to configure a router interface to run DDN X.25:

```
interface serial 0
ip address 192.31.7.50 255.255.255.240
encapsulation x25 ddn
x25 win 6
x25 wout 6
x25 ips 1024
x25 ops 1024
```

```
x25 t20 10
x25 t21 10
x25 t22 10
x25 t23 10
x25 nvc 2
x25 map IP 192.31.7.49 000000010300 BROADCAST
```

Blacker Front End Example

In the following example, interface serial 0 is configured to attach to the DDN X.25 network via a Blacker Front End.

```
interface serial 0
 ip address 21.0.0.2 255.0.0.0
 encapsulation x25 bfe
```

X.25 Ping Support over Multiple Lines Example

For **ping** commands to work in an X.25 environment (when load sharing is occurring over multiple serial lines), you must include entries for all adjacent interface IP addresses in the **x25 map** command for each serial interface. The following example illustrates this point.

Consider two routers, router A and router B, communicating with each other over two serial lines via an X.25 PDN (see the figure below) or over leased lines. In either case, all serial lines must be configured for the same IP subnet address space. The configuration that follows allows for successful **ping** commands. A similar configuration is required for the same subnet IP addresses to work across X.25.

Figure 17 Parallel Serial Lines to an X.25 Network

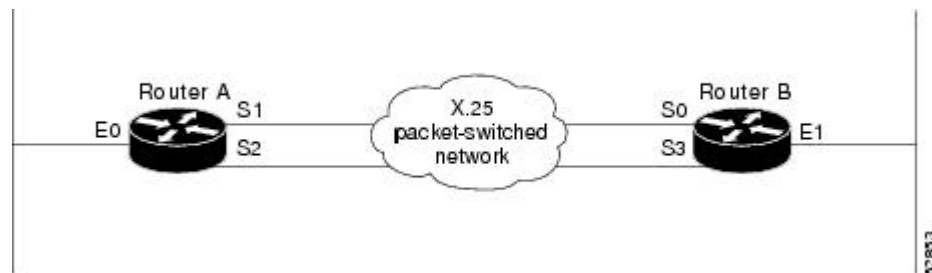

Note

All four serial ports configured for the two routers in the following configuration example must be assigned to the same IP subnet address space. In this case, the subnet is 172.20.170.0.

Configuration for Router A

```
interface serial 1
 ip 172.20.170.1 255.255.255.0
 x25 address 31370054068
 x25 alias ^31370054069$
 x25 map ip 172.20.170.3 31370054065
 x25 map ip 172.20.170.4 31370054065
!
interface serial 2
 ip 172.20.170.2 255.255.255.0
 x25 address 31370054069
 x25 alias ^31370054068$
```

```
x25 map ip 172.20.170.4 31370054067
x25 map ip 171.20.170.3 31370054067
! allow either destination address
```

Configuration for Router B

```
interface serial 0
 ip 172.20.170.3 255.255.255.0
 x25 address 31370054065
 x25 alias ^31370054067$
 x25 map ip 172.20.170.1 31370054068
 x25 map ip 172.20.170.2 31370054068
!
interface serial 3
 ip 172.20.170.4 255.255.255.0
 x25 address 31370054067
 x25 alias ^31370054065$
 x25 map ip 172.20.170.2 31370054069
 x25 map ip 172.20.170.1 31370054069
! allow either destination address
```

Booting from a Network Server over X.25 Example

You cannot boot a router over an X.25 network using broadcasts. Instead, you must boot from a specific host. Also, an **x25 map** command must exist for the host that you boot from. The **x25 map** command maps an IP address to an X.121 address. The **x25 map** command must match the IP address given on the **boot system** command line. The following is an example of such a configuration:

```
boot system gs3-k.100 172.18.126.111
interface Serial 1
 ip address 172.18.126.200 255.255.255.0
 encapsulation X25
 x25 address 10004
 x25 map IP 172.18.126.111 10002 broadcast
 lapb nl 12040
 clockrate 56000
```

In this case, 10002 is the X.121 address of the remote router that can get to host 172.18.126.111. The remote router must have the following **x25 map** entry for the remote router to return a boot image from the host to the router booting over X.25.

```
x25 map IP 172.18.126.200 10004 broadcast
```

X.25 Remote Failure Detection Examples

You must have X.25 encapsulation activated for X.25 remote failure detection to function. See the section [Configuring X.25 Encapsulation, page 38](#) for further details. You must also have IP static routes or a backup link configured for X.25 encapsulation.

These examples show the **x25 retry** command being used only with a secondary route. However, the **x25 retry** command can be configured for as many subinterfaces that require an alternative route. Use either one of the following examples to configure X.25 remote failure detection:

- [X.25 Remote Failure Detection with IP Static Routes Example, page 92](#)
- [X.25 Remote Failure Detection and the Backup Interface Example, page 93](#)

X.25 Remote Failure Detection with IP Static Routes Example

The following is an example of X.25 remote failure detection being configured on subinterfaces 1.1 and 1.2 using the **x25 retry** command. Subinterface 1.1 has been set at a retry every 60 seconds up to a maximum of 10 attempts.

Observe the weighting of 100 on subinterface 1.1 over 200 on subinterface 1.2 in the **ip route** command, because subinterface 1.1 is the primary route and 1.2 is the secondary route. The latter becomes activated only when subinterface 1.1 is unable to function. Weights make for predictable routing events and therefore promote the concept of primary and secondary routes.

```
Router(config)# interface serial1
Router(config-if)# encapsulation x25
Router(config-if)# x25 address 11111
Router(config-if)# exit
Router(config)# interface serial1.1 point-to-point
Router(config-subif)# ip address 172.30.22.1 255.255.255.0
Router(config-subif)# x25 map ip 172.30.22.2 22222
Router(config-subif)# x25 retry interval 60 attempts 10
Router(config-subif)# exit
Router(config)# interface serial1.2 point-to-point
Router(config-subif)# ip address 172.30.22.1 255.255.255.0
Router(config-subif)# x25 map ip 172.30.22.4 44444
Router(config-subif)# exit
Router(config)# ip route 172.30.11.1 255.255.255.0 serial1.1 100
Router(config)# ip route 172.30.11.1 255.255.255.0 serial1.2 200
```

X.25 Remote Failure Detection and the Backup Interface Example

The following configuration example is an alternative to the method previously described. X.25 remote failure detection is configured on subinterface 1.1, and interface 2 is made the backup interface. The **x25 retry** command has been set with an interval of 50 seconds up to a maximum of 20 attempts. In this example, there is no need to configure any IP static routes (as is done with the above configuration) because the backup interface is functioning as the secondary route. In other situations, there may be a need for static IP routes, depending on how the backup interface is configured.

For more details about backup, see the **backup interface** command in the chapter in the *Cisco IOS Dial Technologies Command Reference*.

```
Router(config)# interface serial1
Router(config-if)# encapsulation x25
Router(config-if)# x25 address 11111
Router(config-if)# exit
Router(config)# interface serial1.1 point-to-point
Router(config-subif)# ip address 172.30.22.1 255.255.255.0
Router(config-subif)# x25 map ip 172.30.22.2 22222
Router(config-subif)# x25 retry interval 50 attempts 20
Router(config-subif)# backup interface serial2
Router(config-subif)# exit
Router(config)# interface serial2
Router(config-if)# encapsulation x25
Router(config-if)# x25 address 11111
Router(config-if)# ip address 172.30.22.1 255.255.255.0
Router(config-if)# x25 map ip 172.30.22.3 33333
Router(config-if)# exit
```

X.29 Access List Example

The following example illustrates an X.29 access list. Incoming permit conditions are set for all IP hosts and LAT nodes that have specific characters in their names. All X.25 connections to a printer are denied. Outgoing connections are list restricted.

```
!Permit all IP hosts and LAT nodes beginning with "VMS".
!Deny X.25 connections to the printer on line 5.
```

```

!
access-list 1 permit 0.0.0.0 255.255.255.255
  lat access-list 1 permit ^VMS.*
  x29 access-list 1 deny .*
!
line vty 5
  access-class 1 in
!
!Permit outgoing connections for other lines.
!
!Permit IP access with the network 172.30
access-list 2 permit 172.30.0.0 0.0.255.255
!
!Permit LAT access to the boojum/snark complexes.
  lat access-list 2 permit ^boojum$
  lat access-list 2 permit ^snark$
!
!Permit X.25 connections to Infonet hosts only.
  x29 access-list 2 permit ^31370
!
line vty 0 16
  access-class 2 out

```

X.29 Profile Script Example

The following profile script turns local edit mode on when the connection is made and establishes local echo and line termination upon receipt of a Return. The name *linemode* is used with the **translate** command to effect use of this script.

```

x29 profile linemode 2:1 3:2 15:1
translate tcp 172.30.1.26 x25 55551234 profile linemode

```

The X.3 PAD parameters set in the profile file and the **translate** command are described in the chapter "Configuring Protocol Translation and Virtual Asynchronous Devices" in the *Cisco IOS Terminal Services Configuration Guide*.

Cisco and the Cisco Logo are trademarks of Cisco Systems, Inc. and/or its affiliates in the U.S. and other countries. A listing of Cisco's trademarks can be found at www.cisco.com/go/trademarks. Third party trademarks mentioned are the property of their respective owners. The use of the word partner does not imply a partnership relationship between Cisco and any other company. (1005R)

Any Internet Protocol (IP) addresses and phone numbers used in this document are not intended to be actual addresses and phone numbers. Any examples, command display output, network topology diagrams, and other figures included in the document are shown for illustrative purposes only. Any use of actual IP addresses or phone numbers in illustrative content is unintentional and coincidental.

© 2011 Cisco Systems, Inc. All rights reserved.