



# QoS CBQoS Management Policy-to-Interface Mapping Support

---

The QoS CBQoS Management Policy-to-Interface Mapping Support feature lets you use Simple Network Management Protocol (SNMP) to find which service policy is applied to a particular interface, without having to search the entire service policy table in the CISCO-CLASS-BASED-QOS-MIB. This feature introduces the CISCO-CBP-TARGET-MIB, which stores these mappings.

- [Finding Feature Information, page 1](#)
- [Prerequisites for QoS CBQoS Management Policy-to-Interface Mapping Support, page 2](#)
- [Restrictions for QoS CBQoS Management Policy-to-Interface Mapping Support, page 2](#)
- [Information About QoS CBQoS Management Policy-to-Interface Mapping Support, page 2](#)
- [How to Configure QoS CBQoS Management Policy-to-Interface Mapping Support, page 8](#)
- [Configuration Examples for QoS CBQoS Management Policy-to-Interface Mapping Support, page 8](#)
- [Additional References, page 8](#)
- [Feature Information for QoS CBQoS Management Policy-to-Interface Mapping Support, page 9](#)

## Finding Feature Information

Your software release may not support all the features documented in this module. For the latest caveats and feature information, see [Bug Search Tool](#) and the release notes for your platform and software release. To find information about the features documented in this module, and to see a list of the releases in which each feature is supported, see the feature information table at the end of this module.

Use Cisco Feature Navigator to find information about platform support and Cisco software image support. To access Cisco Feature Navigator, go to [www.cisco.com/go/cfn](http://www.cisco.com/go/cfn). An account on Cisco.com is not required.

## Prerequisites for QoS CBQoS Management Policy-to-Interface Mapping Support

- You must enable SNMP on a Cisco router that supports the CISCO-CBP-TARGET-MIB.
- You must configure policy maps and attach them to interfaces in an input or output direction within your network.

## Restrictions for QoS CBQoS Management Policy-to-Interface Mapping Support

- The CISCO-CBP-TARGET-MIB is limited to read-only (RO) permission for MIB objects.

## Information About QoS CBQoS Management Policy-to-Interface Mapping Support

### Feature Overview of QoS CBQoS Management Policy-to-Interface Mapping Support

To find the QoS service policies that are applied to a specific interface (more generically referred to as a target), you must search the entire `cbQoSServicePolicyTable` within the `CISCO-CLASS-BASED-QOS-MIB`. This process can be very time consuming in large scale configurations, and therefore, is not feasible.

A solution was to create the `CISCO-CBP-TARGET-MIB`, a more generic MIB that allows any type of target to be mapped to the service policies that are applied to it.

The `CISCO-CBP-TARGET-MIB` maps policy targets to their corresponding attached service policies by providing a link to the policy instance (service policy) and the policy-map configuration data by using row pointers to the tables that manage each one. For policy types in the `CISCO-CLASS-BASED-QOS-MIB`, the `CISCO-CBP-TARGET-MIB` maps targets to their `cbQoSServicePolicyTable` and `cbQoSPolicyMapCfgTable` rows, respectively.

The figure below shows the relationship between the CISCO-CBP-TARGET-MIB and the CISCO-CLASS-BASED-QOS-MIB.

**Figure 1: Relationship Between the CISCO-CBP-TARGET-MIB and the CISCO-CLASS-BASED-QOS-MIB**

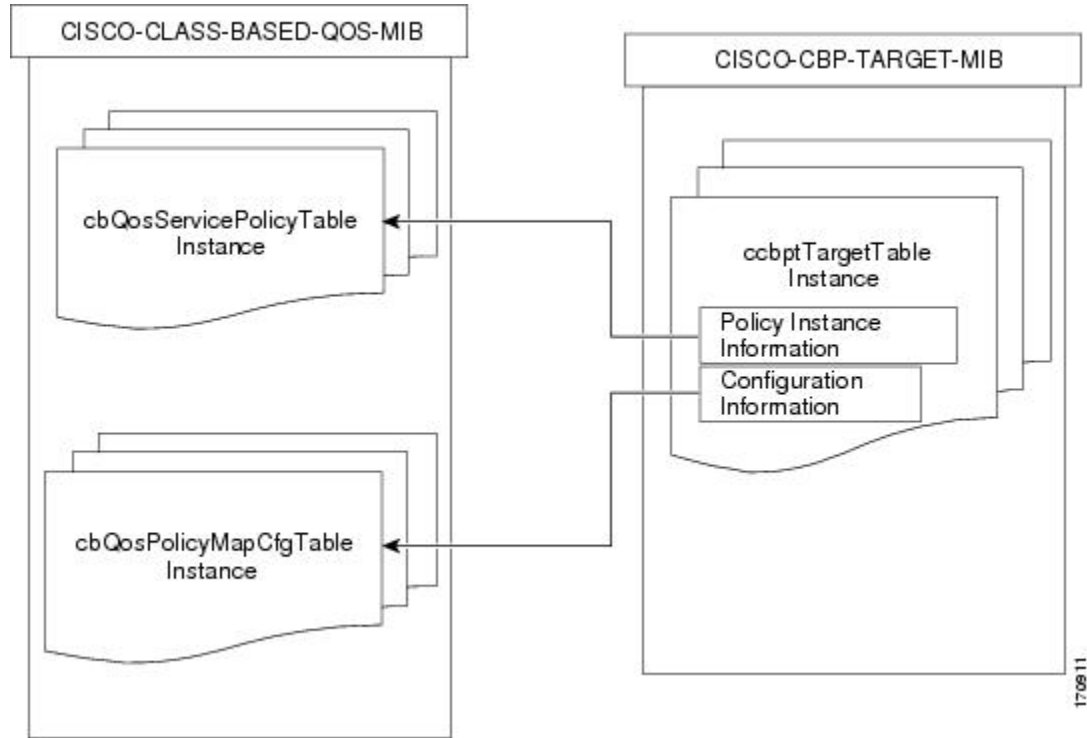

**CISCO-CBP-TARGET-MIB Objects and Descriptions**

The CISCO-CBP-TARGET-MIB consists of the ccbptTargetTable, which describes the class-based policy attachments to specific targets.

The table below lists the CISCO-CBP-TARGET-MIB objects and their descriptions.

**Table 1: CISCO-CBP-TARGET-MIB Objects and Descriptions**

Object	Description
ccbptPolicyIdNext	Indicates the next available value of ccbptPolicyId that can be used to create a new conceptual row in the ccbptTargetTable. This is a scalar object that is read-only and, therefore, has a value of 0.
ccbptTargetEntry	Describes a class-based policy attachment to a particular target. <b>Note</b> This is not a pollable object that is present in the MIB.

Object	Description
ccbptTargetType	<p>Indicates the type of target, such as an ifIndex, an ATM virtual circuit (VC), a Frame Relay data-link connection identifier (DLCI), or a control plane. Values are as follows:</p> <ul style="list-style-type: none"> <li>• If the target type equals 1, then the target is an ifIndex.</li> <li>• If the target type equals 2, then the target is an ATM VC.</li> <li>• If the target type equals 3, then the target is a Frame Relay DLCI.</li> <li>• If the target type equals 4, then the target is a control plane.</li> </ul>
ccbptTargetId	Gives the target identifier in the format indicated by the target type. This object contains variable length octets that are interpreted according to the value of the target type.
ccbptTargetDir	Indicates the direction, input(2) or output(3), relative to the target.
ccbptPolicySourceType	Shows the type of policy applied to the target and shows the cbQoS MIB relationship.
ccbptPolicyId	Contains the cbQoSPolicyIndex value for this instance of the service policy applied to the target. This object is an arbitrary integer that is used to identify a service policy.
ccbptTargetStatus	Indicates the status of the row. This object is always active(1).
ccbptTargetStorageType	Indicates the storage type for the row. This object is always volatile(2).
ccbptPolicyMap	Points to a row in the cbQoSPolicyMapCfgTable indicating the configuration of the policy map for this target.
ccbptPolicyInstance	Points to a row in the cbQoSServicePolicyTable indicating the instance of the policy map attached to this target.
ccbptPolicyAttachTime	Shows the time that this policy map was attached.

Object	Description
ccbptTargetTableLastChange	Shows the time that an entry was added or removed. This is a scalar object that is not part of the ccbptTargetTable entry.

**Decoding Index Values**

The CISCO-CBP-TARGET-MIB contains objects that define textual conventions for representing targets that have class-based policy mappings. A target can be any logical interface or entity to which a class-based policy can be applied.

The ccbptTarget is a series of octets that should be interpreted according to the value of ccbptTargetType.

The figure below shows a sample index with the type genIf(1) and how to decode index values corresponding to configuration mapping data output.

**Figure 2: Sample Index with Mapping Data Output**

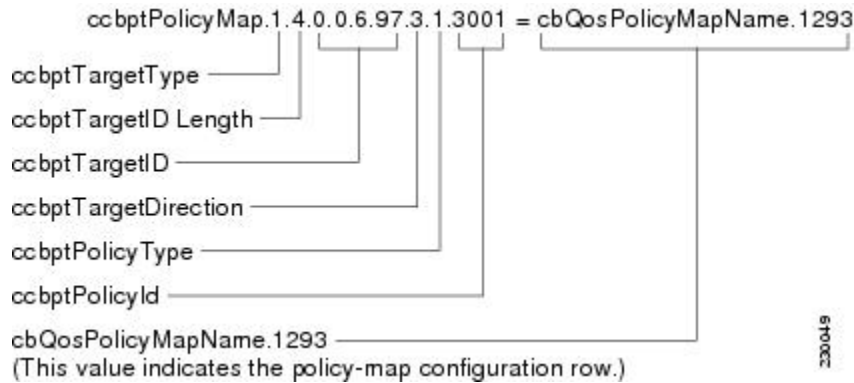

The figure above shows the mapping of the index portion of the object identifier (OID) for an instance of the ccbptPolicyMap object. Each portion of the index is defined as follows:

Configuration Policy Mapping Data

-----  
 ccbptPolicyMap.1.4.0.0.6.97.3.1.3001 = cbQosPolicyMapName.1293

Where from left to right:

- ccbptTargetType--Value of 1 indicates the ccbptTargetType which is genIf(1). The target type indicates that the value contained in the ccbptTargetId is an ifIndex value.
- ccbptTargetId Length--Value of 4 indicates that the length of the ccbptTargetId to follow is 4 bytes. The ccbptTargetId is defined in the MIB as a variable length octet string. Representing this object in the index of a table requires that the object be preceded by the length of an octet string.
- ccbptTargetId--Value of 0.0.6.97 indicates the target ID. The length of the third index is determined by the value in the second byte of the entire index. (In this example, the length of the target ID is 4 bytes.) For supported ccbptTargetId values, see the [Feature Overview of QoS CBQoS Management Policy-to-Interface Mapping Support](#), on page 2.

### Numerical Value for the ifIndex Example

The figure below shows the numerical value of the ifIndex ccbptTargetId, 0.0.6.97.

**Figure 3: Numerical Value for an ifIndex**

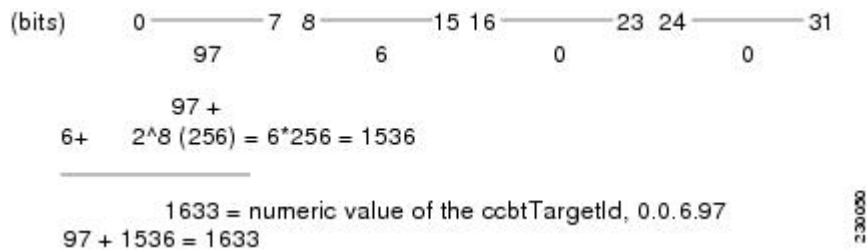

- ccbptTargetDirection--Value of 3 indicates the ccbptTarget output direction.
- ccbptPolicyType--Value of 1 indicates the ccbptPolicyType, which is ciscoCbQos(1).
- ccbptPolicyId--Value of 3001 indicates the ccbptPolicyId, which is the policy index integer for the policy instance applied to the target. The value of 3001 equals the value of the cbQosPolicyIndex for the corresponding entry in the cbQosServicePolicyTable in the CISCO-CLASS-BASED-QOS-MIB.
- cbQosPolicyMapName.1293--Value indicates the row in the cbQosPolicyMapTable describing the configuration of the policy map applied to the output direction of this ccbptTargetId.

### Possible Values for ccbptTargetId

The figure below shows the supported ccbptTargetId values.

**Figure 4: ccbptTargetId Values**

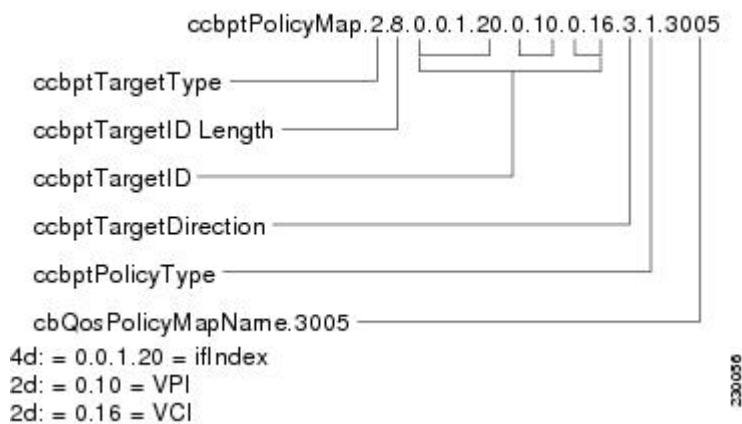

- For genIf(1), OCTET STRING (SIZE(4))--ifIndex (4d). Where the (4d) value is a 4-byte decimal for the length of the ccbptTargetId in the example.
- For atmPvc(2), OCTET STRING (SIZE(8))--ATM PVC (4d:2d:2d). Where the ATM PVC has a ccbptTargetId length of 8 bytes (4d:2d:2d).
- For frDlci(3), OCTET STRING(SIZE(6))--Frame Relay ifIndex is the first 4 bytes, and DLCI is the last 2 bytes (4d:2d).

- For controlPlane(4), OCTET STRING(SIZE(4))--Control Plane Entity (4d).

### Objects in the CISCO-CBP-TARGET-MIB

The notation used in the CISCO-CBP-TARGET-MIB follows the conventions defined in Abstract System Notation One (ASN.1). ASN.1 defines an Open System Interconnection (OSI) language used to describe data types independently from particular computer structures and presentation techniques. Each object in the MIB incorporates a DESCRIPTION field that includes an explanation of the object's meaning and usage, which, together with the other characteristics of the object (SYNTAX, MAX-ACCESS, and INDEX), provides sufficient information for management application development, as well as for documentation and testing.

A network administrator can access the entries (objects) in the CISCO-CBP-TARGET-MIB by means of any SNMP-based network management system (NMS). The network administrator can retrieve information in the CISCO-CBP-TARGET-MIB using standard SNMP **get** and **getnext** operations.

### Scalar Objects in the CISCO-CBP-TARGET-MIB

The CISCO-CBP-TARGET-MIB contains the following unsupported scalar object:

- ccbptPolicyNext--Indicates the next available value of ccbptPolicyId that can be used to create a new conceptual row in the ccbptTargetTable. If no available identifier exists, this object has a value of 0. This object is read-only and is unsupported.

The CISCO-CBP-TARGET-MIB contains the following supported scalar object:

- ccbptTargetTableLastChange--Shows the value of sysUpTime at the time of the last addition or deletion of an entry in the ccbptTargetTable. If the number of entries is unchanged since the last reinitialization of the local network management system, the value of this object is 0. This object is read-only and is supported.

### Notifications in the CISCO-CBP-TARGET-MIB

There are no notifications in the CISCO-CBP-TARGET-MIB.

## Benefits of QoS CBQoS Management Policy-to-Interface Mapping Support

In deployments where service policies are applied to several thousand interfaces, obtaining QoS statistics and configuration information on a per interface or target basis is difficult using the organization of the CISCO-CLASS-BASED-QOS-MIB. You must perform a linear search of the cbQosServicePolicyTable within the MIB to find the corresponding cbQosPolicyIndex and then search for the configuration and statistics for the service policy applied to the interface (target).

The CISCO-CBP-TARGET-MIB offers a direct mapping from the target to the service policy applied to the target and provides the configuration information for that same service policy.

# How to Configure QoS CBQoS Management Policy-to-Interface Mapping Support

There is no special way to configure this feature. For information on SNMP and QoS configuration tasks, see the "Configuring SNMP Support" module, the Cisco IOS Network Management Command Reference, and the Cisco IOS Quality of Service Solutions Command Reference, respectively.

## Configuration Examples for QoS CBQoS Management Policy-to-Interface Mapping Support

There is no explicit way to configure the CISCO-CBP-TARGET-MIB. For SNMP and QoS examples, see the "Configuring SNMP Support" module, the Cisco IOS Network Management Command Reference, and the Cisco IOS Quality of Service Solutions Command Reference.

## Additional References

### Related Documents

Related Topic	Document Title
QoS commands: complete command syntax, command modes, command history, defaults, usage guidelines, and examples	<i>Cisco IOS Quality of Service Solutions Command Reference</i>
QoS features	"Quality of Service Overview" module
SNMP commands: complete command syntax, command modes, command history, defaults, usage guidelines, and examples	<i>Cisco IOS Network Management Command Reference</i>
SNMP configuration tasks	Configuring SNMP Support" module
Other documentation	For information on using SNMP MIB features, see the appropriate documentation for your network management system.

### Standards

Standard	Title
No new or modified standards are supported by this feature, and support for existing standards has not been modified by this feature.	--



**MIBs**

<b>MIB</b>	<b>MIBs Link</b>
<ul style="list-style-type: none"> <li>• CISCO-AAA-SESSION-MIB</li> <li>• CISCO-CLASS-BASED-QOS-MIB</li> </ul>	To locate and download MIBs for selected platforms, Cisco IOS XE Software releases, and feature sets, use Cisco MIB Locator found at the following URL: <a href="http://www.cisco.com/go/mibs">http://www.cisco.com/go/mibs</a>

**RFCs**

<b>RFC</b>	<b>Title</b>
RFC 1156	<i>Management Information Base for Network Management of TCP/IP-based Internets</i>
RFC 1157	<i>A Simple Network Management Protocol (SNMP)</i>
RFC 1213	<i>Management Information Base for Network Management of TCP/IP-based Internets: MIB-II</i>

**Technical Assistance**

<b>Description</b>	<b>Link</b>
The Cisco Support and Documentation website provides online resources to download documentation, software, and tools. Use these resources to install and configure the software and to troubleshoot and resolve technical issues with Cisco products and technologies. Access to most tools on the Cisco Support and Documentation website requires a Cisco.com user ID and password.	<a href="http://www.cisco.com/cisco/web/support/index.html">http://www.cisco.com/cisco/web/support/index.html</a>

## Feature Information for QoS CBQoS Management Policy-to-Interface Mapping Support

The following table provides release information about the feature or features described in this module. This table lists only the software release that introduced support for a given feature in a given software release train. Unless noted otherwise, subsequent releases of that software release train also support that feature.

Use Cisco Feature Navigator to find information about platform support and Cisco software image support. To access Cisco Feature Navigator, go to [www.cisco.com/go/cfn](http://www.cisco.com/go/cfn). An account on Cisco.com is not required.

**Table 2: Feature Information for QoS CBQoS Management Policy-to-Interface Mapping Support**

Feature Name	Releases	Feature Information
QoS CBQoS Management Policy-to-Interface Mapping Support	Cisco IOS XE Release 2.1	<p>The QoS CBQoS Management Policy-to-Interface Mapping Support feature lets you use SNMP to find which service policy is applied to a particular interface, without having to search the entire service policy table in the CISCO-CLASS-BASED-QOS-MIB. This feature introduces the CISCO-CBP-TARGET-MIB, which stores these mappings.</p> <p>This feature was introduced on Cisco ASR 1000 Series Routers.</p>