



MPLS VPN--Inter-AS Option AB

The MPLS VPN--Inter-AS Option AB feature combines the best functionality of an Inter-AS Option (10) A and Inter-AS Option (10) B network to allow a Multiprotocol Label Switching (MPLS) Virtual Private Network (VPN) service provider to interconnect different autonomous systems to provide VPN services. These networks are defined in RFC 4364 section 10 “Multi-AS Backbones,” subsections a and b, respectively.

When different autonomous systems are interconnected in an MPLS VPN--Inter-AS Option AB configuration, the entire network configuration is scaled and simplified, and maintains IP quality of service (QoS) functions between Autonomous System Boundary Router (ASBR) peers.

In an Inter-AS Option A network, ASBR peers are connected by multiple subinterfaces with at least one interface VPN that spans the two autonomous systems. These ASBRs associate each subinterface with a VPN routing and forwarding (VRF) instance and a Border Gateway Protocol (BGP) session to signal unlabeled IP prefixes. As a result, traffic between the back-to-back VRFs is IP. In this scenario, the VPNs are isolated from each other, and because the traffic is IP, QoS mechanisms that operate on IP traffic can be applied to achieve customer Service Level Agreements (SLAs). The downside of this configuration is that one BGP session is needed for each subinterface (and at least one subinterface for each VPN), which causes scalability concerns as this network grows.

In an Inter-AS Option B network, ASBR peers are connected by one or more subinterfaces that are enabled to receive MPLS traffic. A Multiprotocol Border Gateway Protocol (MP-BGP) session is used to distribute labeled VPN prefixes between the ASBR. As a result, the traffic that flows between them is labeled. The downside of this configuration is that, because the traffic is MPLS, QoS mechanisms that can be applied only to IP traffic cannot be applied and the VRFs cannot be isolated.

- [Finding Feature Information, on page 2](#)
- [Prerequisites for MPLS VPN--Inter-AS Option AB, on page 2](#)
- [Restrictions for MPLS VPN--Inter-AS Option AB, on page 2](#)
- [Information About MPLS VPN--Inter-AS Option AB, on page 2](#)
- [How to Configure Inter-AS Option AB, on page 10](#)
- [Configuration Examples for MPLS VPN--Inter-AS Option AB, on page 18](#)
- [Additional References, on page 42](#)
- [Feature Information for MPLS VPN--Inter-AS Option AB, on page 43](#)
- [Glossary, on page 44](#)

Finding Feature Information

Your software release may not support all the features documented in this module. For the latest caveats and feature information, see [Bug Search Tool](#) and the release notes for your platform and software release. To find information about the features documented in this module, and to see a list of the releases in which each feature is supported, see the feature information table.

Use Cisco Feature Navigator to find information about platform support and Cisco software image support. To access Cisco Feature Navigator, go to www.cisco.com/go/cfn. An account on Cisco.com is not required.

Prerequisites for MPLS VPN--Inter-AS Option AB

Follow the appropriate configuration tasks outlined in the following documents:

- Configuring MPLS Layer 3 VPNs
- MPLS VPN Inter-AS with ASBRs Exchanging VPN-IPv4 Addresses
- MPLS VPN Inter-AS with ASBRs Exchanging IPv4 Routes and MPLS Labels

Before configuring the MPLS VPN--Inter-AS Option AB feature, perform these tasks:

- Enable Cisco Express Forwarding, which is required for the MPLS VPN routing and forwarding operation.
- Identify the VPNs for the MPLS VPN--Inter-AS Option AB network and configure the VRFs to which these VPNs belong. These VRFs are used for Inter-AS Option AB connections on the ASBR interface.

Restrictions for MPLS VPN--Inter-AS Option AB

- The In Service Software Upgrade (ISSU) feature can be configured only on the active Route Processor (RP) if the standby RP supports this feature. The ISSU feature can be configured if both the active and standby RP support this feature.
- Carrier Supporting Carrier (CSC) MPLS load-balancing on ASBR Option AB VRF interfaces is not supported.
- VPNv6 is not supported.

Information About MPLS VPN--Inter-AS Option AB

MPLS VPN--Inter-AS Option AB Introduction

MPLS VPN service providers need to interconnect different autonomous systems to provide service for multiple VPN customers. The MPLS VPN--Inter-AS Option AB feature allows the different autonomous systems to interconnect by using a single MP-BGP session in the global routing table to carry control plane traffic. This MP-BGP session signals VPN prefixes between two ASBRs for each VRF instance. The data plane traffic is on a VRF interface. This traffic can either be IP or MPLS.



Note Inter-AS connections can be configured between ASBRs that either have or do not have connections between different providers.

Benefits of MPLS VPN--Inter-AS Option AB

The MPLS VPN--Inter-AS Option AB feature provides the following benefits for service providers:

- Network configuration can be simplified because only one BGP session is configured for each VRF on the ASBR.
- One BGP session reduces CPU utilization.
- Networks can be scaled because a single MP-BGP session, which is enabled globally on the router, reduces the number of sessions required by multiple VPNs, while continuing to keep VPNs isolated and secured from each other.
- IP QoS functions between ASBR peers are maintained for customer SLAs.
- Dataplane traffic is isolated on a per-VRF basis for security purposes.

Option B Style Peering with Shared Link Forwarding

An enhancement to Inter-AS Option AB is the MPLS VPN—Inter-AS Option AB+ feature. This feature addresses the scalability concerns of MPLS VPN—Inter-AS Option A by using a single BGP session in the global routing table to signal VPN prefixes (as described in Inter-AS Option B).

The key difference between Option AB+ and Option B is in the route distribution between ASBRs. In Option AB+, at the ASBR, the route that is imported into the VRF (with the route distinguisher and route targets of the VRF) is distributed to the neighboring ASBR. In Option B, the original pre-import route (with the original RD and RTs) is distributed to the neighboring ASBR and not the imported route.

With Option AB+, the PE and ASBRs deploy MPLS forwarding over a global interface, similar to what is done in Option B, and the signaling is handled by a single MP-eBGP VPNv4 session. The provider edge and ASBRs thus use regular Option B style peering between them. They receive MPLS-VPN traffic over the shared link and forward the traffic as per an IP lookup in the VRF routing table. However, the traffic is MPLS encapsulated, like it is in Option B.

Route Distribution and Packet Forwarding in Non-CSC Networks

The following sections describe MPLS VPN--Inter-AS Option AB operation:



Note All imported routes are accomplished by configuring the appropriate route targets (RTs).

The following attributes describe the topology of the sample MPLS VPN--Inter-AS Option AB network shown in the figure below:

- Customer edge 1 (CE1) and CE3 belong to VPN 1.

- CE2 and CE 4 belong to VPN 2.
- Provider edge 1 (PE1) uses route distinguisher 1 (RD 1) for VPN 1 (VRF 1) and RD 2 for VPN 2 (VRF 2).
- PE2 uses RD 3 for VPN 1 (VRF 1) and RD 4 for VPN 2 (VRF 2).
- ASBR1 has VRF 1 provisioned with RD 5 and VRF 2 provisioned with RD 6.
- ASBR2 has VRF 1 provisioned with RD 7 and VRF 2 provisioned and RD 8.
- ASBR1 and ASBR2 have three links between them:
 - VRF 1
 - VRF 2
 - MP-BGP session



Note The VRFs configured on the ASBRs are called Option AB VRFs. The eBGP peers on the ASBRs are called Option AB Peers.

Figure 1: MPLS VPN Inter-AS Option AB Topology

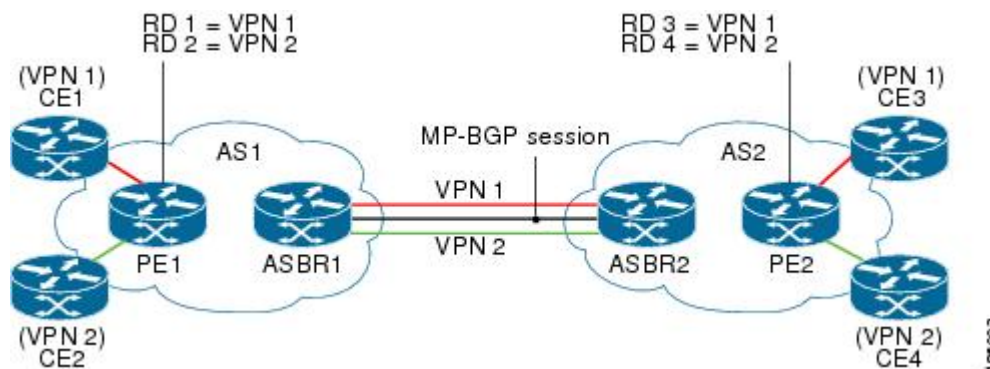

Route Distribution for VPN 1

A route distinguisher (RD) is an identifier attached to a route that identifies which VPN belongs to each route. Each routing instance must have a unique RD autonomous system associated with it. The RD is used to place a boundary around a VPN so that the same IP address prefixes can be used in different VPNs without having these IP address prefixes overlap.



Note An RD statement is required if the instance type is a VRF.

The following process describes the route distribution process for VPN 1 in the figure above. Prefix “N” is used in this process to indicate the IP address of a VPN.

1. CE1 advertises the prefix N to PE1.
2. PE1 advertises a VPN prefix RD 1:N to ASBR1 through MP internal BGP (iBGP).

3. ASBR1 imports the prefix into VPN 1 and creates a prefix RD 5:N.
4. ASBR1 advertises the imported prefix RD 5:N to ASBR2. ASBR1 sets itself as the next hop for prefix RD 5:N and allocates a local label that is signaled with this prefix.
5. ASBR1 advertises the route with the export RT configured on the VRF rather than the originally received RTs. By default, ASBR1 does not advertise the source prefix RD 1:N to ASBR2. This advertisement is suppressed because the prefix is being imported into an Option AB VRF.



Note In an Option 10B connection, the source prefix can be advertised to another ASBR on which ASBR1 has an Option 10B connection. An ASBR with an Option 10B connection maintains all VPNv4 routes in its BGP table.

1. ASBR2 receives the prefix RD 5:N and imports it into VPN 1 as RD 7:N.
2. ASBR2 advertises the route with the export RT configured on the VRF rather than the originally received RTs.
3. While importing the prefix, ASBR2 sets the next hop of RD 7:N to the ASBR1 interface IP address in VRF 1. The next hop table ID is also set to VRF 1. When installing the MPLS forwarding entry for RD 7:N, by default ASBR2 does not install the outgoing label in the forwarding process. This enables the traffic between the ASBRs to be IP.
4. ASBR2 advertises the imported prefix RD 7:N to PE2. It sets itself as the next hop for this prefix and also allocates a local label that is signaled with the prefix. By default, ASBR2 does not advertise the source prefix RD 5:N to PE2. This advertisement is suppressed because the prefix is being imported into an Option AB VRF.
5. PE2 imports the RD 7:N into VRF 1 as RD 3:N.

Packet Forwarding for VPN 1

The following packet forwarding process works the same as it does in an Option A scenario. The ASBR acts like the PE by terminating the VPN and then forwards its traffic as standard IP packets with no VPN label to the next PE, which in turn repeats the VPN process. Each PE router, therefore, treats the adjacent PE router as a CE router, and the standard Layer 3 MPLS VPN mechanisms are used for route redistribution with each autonomous system; that is, the PEs use external BGP (eBGP) to distribute unlabeled IPv4 addresses to each other.



Note Prefix “N” is used in this process to indicate the IP address of a VPN.

1. CE3 sends a packet destined for N to PE2.
2. PE2 encapsulates the packet with the VPN label allocated by ASBR2 and the Interior Gateway Protocol (IGP) label needed to tunnel the packet to ASBR2.
3. The packet arrives on ASBR2 with the VPN label. ASBR2 removes the VPN label and sends the packet as IP to ASBR1 on the VRF 1 interface.

4. The IP packet arrives at ASBR1 on the VRF 1 interface. ASBR1 then encapsulates the packet with the VPN label allocated by PE1 and the IGP label needed to tunnel the packet to PE1.
5. The packet arrives on PE1 with the VPN label. PE1 disposes the VPN label and forwards the IP packet to CE1.

Route Distribution for VPN 2

The following information describes the route distribution process for VPN 2 in the figure above:

1. CE2 advertises prefix N to PE1, where N is the VPN IP address.
2. PE1 advertises a VPN prefix RD 2:N to ASBR1 through MP-iBGP.
3. ASBR1 imports the prefix into VPN 2 and creates a prefix RD 6:N.
4. ASBR1 advertises the imported prefix RD 6:N to ASBR2. It sets itself as the next hop for this prefix and also allocates a local label that is signaled with the prefix. By default, ASBR1 does not advertise the source prefix RD 2:N to ASBR2. This advertisement is suppressed as the prefix is being imported into an Option AB VRF.



Note

In the case of an Option 10B connection, the source prefix can be advertised to another ASBR on which ASBR1 has an Option 10B connection. An ASBR with an Option 10B connection maintains all VPNv4 routes in its BGP table.

1. ASBR2 receives the prefix RD 6:N and imports it into VPN 2 as RD 8:N.
2. While importing the prefix, ASBR2 sets the next hop of RD 8:N to ASBR1's interface address in VRF 2. The next hop table ID is also set to that of VRF 2. While installing the MPLS forwarding entry for RD 8:N, by default ASBR2 does not install the outgoing label in the forwarding process. This enables traffic between the ASBRs to be IP.
3. ASBR2 advertises the imported prefix RD 8:N to PE2. It sets itself as the next hop for this prefix and also allocates a local label that is signaled with the prefix. By default, ASBR2 does not advertise the source prefix RD 6:N to PE2. This advertisement is suppressed because the prefix is being imported into an Option AB VRF.
4. PE2 imports the RD 8:N into VRF 2 as RD 4:N.

Route Distribution and Packet Forwarding for CSC

The following sections describe MPLS VPN--Inter-AS Option AB operation for a CSC scenario for VPN 1. These sections are similar to those found in Route Distribution and Packet Forwarding in Non-CSC Networks for VPN 1, except for the method in which MPLS labels are handled between the two ASBRs.



Note

VPN 2 is not shown or discussed in this section.

The figure below shows how VPN 1 provides VPN service to a small customer carrier that in turn provides a VPN service to its customer. This configuration implies that VPN 1 is used to provide a label switched path (LSP) between the PE (PE 3 and PE 4) loopback interfaces of the small customer carrier.

Figure 2: MPLS VPN Inter-AS Option AB CSC Topology

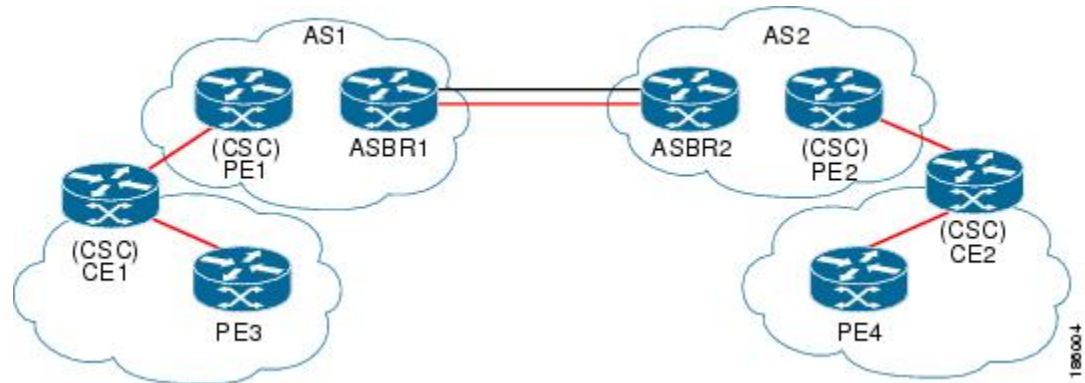

Note The RD, RT, VRF, and Link provisioning in this section is the same as in the Route Distribution and Packet Forwarding in Non-CSC Networks example for VPN 1.

Route Distribution for VPN 1

The following information describe the route distribution process for VPN 1 in Figure 1 . Prefix “N” is used in these steps to indicate the IP address of a VPN.

1. CE1 advertises PE 3 loopback N to PE1.
2. PE1 advertises a VPN prefix RD 1:N to ASBR1 through MP-iBGP.
3. ASBR1 imports the prefix into VPN 1 and creates a prefix RD 5:N.
4. ASBR1 advertises the imported prefix RD 5:N to ASBR2. It sets itself as the next hop for this prefix and also allocates a local label that is signaled with the prefix.
5. ASBR1 advertises the route with the export RT configured on the VRF rather than the originally received RTs. By default, ASBR1 does not advertise the source prefix RD 1:N to ASBR2. This advertisement is suppressed as the prefix is being imported into an Option AB VRF.



Note In an Option 10B connection, the source prefix can be advertised to another ASBR on which ASBR1 has an Option 10B connection. An ASBR with an Option 10B connection maintains all VPNv4 routes in its BGP table.

1. ASBR2 receives the prefix RD 5:N and imports it into VPN 1 as RD 7:N.
2. ASBR2 advertises the route with the export RT configured on the VRF rather than the originally received RTs.

3. While importing the prefix, ASBR2 sets the next hop of RD 7:N to the ASBR1 interface address in VRF 1. The next hop table ID is also set to that of VRF 1.



Note In a CSC scenario, an outgoing MPLS label can be installed in forwarding by making a configuration change. See the [How to Configure Inter-AS Option AB, on page 10](#).

1. While installing the MPLS forwarding entry for RD 7:N, ASBR2 installs the outgoing label during the forwarding process, which enables the traffic between the ASBRs to be MPLS traffic.
2. ASBR2 advertises the imported prefix RD 7:N to PE2. It sets itself as the next hop for this prefix and also allocates a local label that is signaled with the prefix. By default, ASBR2 does not advertise the source prefix RD 5:N to PE2. This advertisement is suppressed as the prefix is being imported into an Option AB VRF.
3. PE2 imports the RD 7:N into VRF 1 as RD 3:N.

Packet Forwarding for VPN 1

The packet forwarding process shown below works the same as it does in an Option A scenario. See the Route Distribution and Packet Forwarding in Non-CSC Networks section for more information about Option A.

1. PE 4 sends an MPLS packet destined for N to CE2.
2. CE2 swaps the MPLS label and sends a packet destined for N to PE2.
3. PE2 encapsulates the packet with the VPN label allocated by ASBR2 and the IGP label needed to tunnel the packet to ASBR2.
4. The packet arrives on ASBR2 with the VPN label. ASBR2 swaps the received VPN label with the outgoing label received from ASBR1 and sends the MPLS packet on to the VRF 1 interface.
5. The MPLS packet arrives at ASBR1 on the VRF 1 interface. ASBR1 then swaps the received MPLS label with a label stack consisting of the VPN label allocated by PE1 and the IGP label needed to tunnel the packet to PE1.
6. The packet arrives on PE1 with the VPN label. PE1 disposes the VPN label and forwards the MPLS packet to CE1. CE1 in turn swaps the label and forwards the labeled packet to PE 3.

Shared Link Forwarding in Non-CSC Networks



Note All imported routes are accomplished by configuring the appropriate route targets (RTs).

The following attributes describe the sample network topology shown in the "Route Distribution and Packet Forwarding in Non-CSC Networks" section:

- Customer edge 1 (CE1) and CE3 belong to VPN 1.
- CE2 and CE 4 belong to VPN 2.

- Provider edge 1 (PE1) uses route distinguisher 1 (RD 1) for VPN 1 (VRF 1) and RD 2 for VPN 2 (VRF 2).
- PE2 uses RD 3 for VPN 1 (VRF 1) and RD 4 for VPN 2 (VRF 2).
- ASBR1 has VRF 1 provisioned with RD 5 and VRF 2 provisioned with RD 6.
- ASBR2 has VRF 1 provisioned with RD 7 and VRF 2 provisioned and RD 8.
- ASBR1 and ASBR2 have three links between them:
 - VRF 1
 - VRF 2
 - MP-BGP session



Note The VRFs configured on the ASBRs are called Option AB+ VRFs. The eBGP peers on the ASBRs are called Option AB+ Peers.

The following sections describe MPLS VPN—Inter-AS Option AB+ shared link forwarding in a non-CSC network:

Route Distribution for VPN 1

The following process describe the route distribution process for VPN 1 shown in the figure in the "Route Distribution and Packet Forwarding in Non-CSC Networks" section. Prefix “N” is used in these steps to indicate the IP address of a VPN.

1. CE1 advertises PE 3 loopback N to PE1.
2. PE1 advertises a VPN prefix RD 1:N to ASBR1 through MP-iBGP.
3. ASBR1 imports the prefix into VPN 1 and creates a prefix RD 5:N.
4. ASBR1 advertises the imported prefix RD 5:N to ASBR2. ASBR1 sets itself as the next hop for prefix RD 5:N and also allocates a local label that is signaled with this prefix.
5. By default, ASBR1 does not advertise the source prefix RD 1:N to ASBR2. This advertisement is suppressed because the prefix is being imported into an Option AB+ VRF.



Note In an Option 10B connection, the source prefix can be advertised to another ASBR on which ASBR1 has an Option 10B connection. An ASBR with an Option 10B connection maintains all VPNv4 routes in its BGP table.

1. ASBR2 receives the prefix RD 5:N and imports it into VPN 1 as RD 7:N.
2. While importing the prefix, ASBR2 retains the next hop of RD7:N as received in the BGP update from ASBR2. This is the address of ASBR1 shared interface address in the global table. The next hop tableid is also left unchanged and corresponds to that of the global table
3. When installing the MPLS forwarding entry for RD 7:N, ASBR2 installs the outgoing label in the forwarding process. This enables the traffic between the ASBRs to be IP.

4. ASBR2 advertises the imported prefix RD 7:N to PE2. It sets itself as the next hop for this prefix and also allocates a local label that is signaled with the prefix.
5. By default, ASBR2 does not advertise the source prefix RD 5:N to PE2. This advertisement is suppressed because the prefix is being imported into an Option AB+ VRF.
6. PE2 imports the RD 7:N into VRF 1 as RD 3:N.

Packet Forwarding for VPN1

The following packet forwarding process works the same as it does in an Option B scenario.

1. CE3 sends a packet destined for N to PE2.
2. PE2 encapsulates the packet with the VPN label allocated by ASBR2 and the IGP label needed to tunnel the packet to ASBR2.
3. The packet arrives on ASBR2 with the VPN label. ASBR2 swaps the received VPN label with the outgoing label received from ASBR1 and sends the MPLS packet on the global shared link interface.
4. The MPLS packet arrives at ASBR1 on the global shared link interface. ASBR1 then swaps the received MPLS label with a label stack consisting of the VPN label allocated by PE1 and the IGP label needed to tunnel the packet to PE1.
5. The packet arrives on PE1 with the VPN label. PE1 removes the VPN label and forwards the IP packet to CE1.

How to Configure Inter-AS Option AB

The following sections describe how to configure the Inter-AS Option AB feature on an ASBR for either an MPLS VPN or an MPLS VPN that supports CSC:



Note If Inter-AS Option AB is already deployed in your network and you want to do Option B style peering for some prefixes (that is, implement Inter-AS Option AB+), configure the **inter-as-hybrid global** command as described in the “Configuring the Routing Policy for VPNs that Need Inter-AS Connections” section.

Configuring an Inter-AS Option AB Connection

The following sections are required and describe how to configure an Inter-AS Option AB connection on an ASBR:



Note See the Configuring MPLS Layer 3 VPNs feature module for more information on configuring PE and CE routers in an MPLS VPN.

Configuring the VRFs on the ASBR Interface for Each VPN Customer

Use the following steps to configure the VRFs on the ASBR interface for each VPN customer so that these VPNs have connectivity over the MPLS VPN--Inter-AS Option AB network.



Note The `mpls bgp forwarding` command is used only on the ASBR interface for VRFs that support CSC.

Use all of the steps in the following procedure to configure additional VRFs that need to be configured on the ASBR interface and the VRFs that need to be configured on the peer ASBR interface.

SUMMARY STEPS

1. `enable`
2. `configure terminal`
3. `interface type number`
4. `ip vrf forwarding vrf-name`
5. `mpls bgp forwarding`
6. `end`

DETAILED STEPS

	Command or Action	Purpose
Step 1	enable Example: <pre>Router> enable</pre>	Enables privileged EXEC mode. <ul style="list-style-type: none"> • Enter your password if prompted.
Step 2	configure terminal Example: <pre>Router# configure terminal</pre>	Enters global configuration mode.
Step 3	interface type number Example: <pre>Router(config)# interface Ethernet 5/0</pre>	Specifies the interface to configure and enters interface configuration mode. <ul style="list-style-type: none"> • The <i>type</i> argument specifies the type of interface to be configured. • The <i>number</i> argument specifies the port, connector, or interface card number.
Step 4	ip vrf forwarding vrf-name Example: <pre>Router(config-if)# ip vrf forwarding vpn1</pre>	Associates a VRF with the specified interface or subinterface. <ul style="list-style-type: none"> • The <i>vrf-name</i> argument is the name assigned to a VRF.

	Command or Action	Purpose
Step 5	mpls bgp forwarding Example: <pre>Router(config-if)# mpls bgp forwarding</pre>	(Optional) Configures BGP to enable MPLS forwarding on connecting interfaces for VRFs that must support MPLS traffic. <ul style="list-style-type: none"> • This step applies to a CSC network only.
Step 6	end Example: <pre>Router(config-if)# end</pre>	(Optional) Exits to privileged EXEC mode.

Configuring the MP-BGP Session Between ASBR Peers

BGP propagates reachability information for VPN-IPv4 prefixes among PE routers by means of the BGP multiprotocol extensions (see RFC 2283, *Multiprotocol Extensions for BGP-4*), which define support for address families other than IPv4. Using the extensions ensures that the routes for a given VPN are learned only by other members of that VPN, enabling members of the VPN to communicate with each other.

Follow the steps in this section to configure the MP-BGP session on the ASBR.

Use all of the steps in the following procedure to configure the MP BGP session on the peer ASBR.

SUMMARY STEPS

1. **enable**
2. **configure terminal**
3. **router bgp** *as-number*
4. **neighbor** {*ip-address* | *peer-group-name*} **remote-as** *as-number*
5. **address-family vpnv4** [**unicast**]
6. **neighbor** {*ip-address* | *peer-group-name*} **activate**
7. **neighbor** {*ip-address* | *peer-group-name*} **inter-as-hybrid**
8. **exit-address-family**
9. **end**

DETAILED STEPS

	Command or Action	Purpose
Step 1	enable Example: <pre>Router> enable</pre>	Enables privileged EXEC mode. <ul style="list-style-type: none"> • Enter your password if prompted.
Step 2	configure terminal Example: <pre>Router# configure terminal</pre>	Enters global configuration mode.

	Command or Action	Purpose
Step 3	<p>router bgp <i>as-number</i></p> <p>Example:</p> <pre>Router(config)# router bgp 100</pre>	<p>Configures a BGP routing process and places the router in router configuration mode.</p> <ul style="list-style-type: none"> The <i>as-number</i> argument indicates the number of an autonomous system that identifies the router to other BGP routers and tags the routing information passed along. Valid numbers are from 0 to 65535. Private autonomous system numbers that can be used in internal networks range from 64512 to 65535.
Step 4	<p>neighbor {<i>ip-address</i> <i>peer-group-name</i>} remote-as <i>as-number</i></p> <p>Example:</p> <pre>Router(config-router)# neighbor 192.168.0.1 remote-as 200</pre>	<p>Adds an entry to the BGP or multiprotocol BGP neighbor table.</p> <ul style="list-style-type: none"> The <i>ip-address</i> argument specifies the IP address of the neighbor. The <i>peer-group-name</i> argument specifies the name of a BGP peer group. The <i>as-number</i> argument specifies the autonomous system to which the neighbor belongs.
Step 5	<p>address-family vpnv4 [unicast]</p> <p>Example:</p> <pre>Router(config-router)# address-family vpnv4</pre>	<p>Enters address family configuration mode for configuring routing sessions, such as BGP, that use standard VPNv4 address prefixes.</p> <ul style="list-style-type: none"> The unicast keyword specifies IPv4 unicast address prefixes.
Step 6	<p>neighbor {<i>ip-address</i> <i>peer-group-name</i>} activate</p> <p>Example:</p> <pre>Router(config-router-af)# neighbor 192.168.0.1 activate</pre>	<p>Enables the exchange of information with a neighboring router.</p> <ul style="list-style-type: none"> The <i>ip-address</i> argument specifies the IP address of the neighbor. The <i>peer-group-name</i> argument specifies the name of a BGP peer group.
Step 7	<p>neighbor {<i>ip-address</i> <i>peer-group-name</i>} inter-as-hybrid</p> <p>Example:</p> <pre>Router(config-router-af)# neighbor 192.168.0.1 inter-as-hybrid</pre>	<p>Configures eBGP peer router (ASBR) as an Inter-AS Option AB peer.</p> <ul style="list-style-type: none"> The <i>ip-address</i> argument specifies the IP address of the neighbor. The <i>peer-group-name</i> argument specifies the name of a BGP peer group. If any prefixes are imported into Option AB VRFs, then the imported paths are advertised to this peer. If any prefixes are received from this peer and are imported into Option AB VRFs, then the imported paths are advertised to iBGP peers.

	Command or Action	Purpose
		Note Advertised routes have RTs that are configured on the VRF. Advertised routes do not have their original RTs.
Step 8	exit-address-family Example: Router(config-router-af) # exit-address-family	Exits from address family configuration mode.
Step 9	end Example: Router(config-router-af) # end	(Optional) Exits to privileged EXEC mode.

Configuring the Routing Policy for VPNs that Need Inter-AS Connections

Use the steps in this section to configure VRFs for the VPNs that need Inter-AS connections between ASBR peers, by configuring the appropriate routing policy and Option AB configuration.

Use all of the steps in the following procedure to configure additional VPNs that need Inter-AS Option AB connectivity on this ASBR and the peer ASBR.

SUMMARY STEPS

1. **enable**
2. **configure terminal**
3. **vrf definition** *vrf-name*
4. **rd** *route-distinguisher*
5. **address-family ipv4**
6. **route-target** {**import** | **export** | **both**} *route-target-ext-community*
7. For Inter-AS Option AB+, go to Step 10; otherwise, go to Step 8.
8. **inter-as-hybrid** [**csc**]
9. **inter-as-hybrid** [**csc**] [**next-hop** *ip-address*]
10. **inter-as-hybrid next-hop global**
11. **end**

DETAILED STEPS

	Command or Action	Purpose
Step 1	enable Example: Router> enable	Enables privileged EXEC mode. <ul style="list-style-type: none"> • Enter your password if prompted.
Step 2	configure terminal Example:	Enters global configuration mode.

	Command or Action	Purpose
	Router# configure terminal	
Step 3	vrf definition <i>vrf-name</i> Example: Router(config)# vrf definition vpn1	Defines the VPN routing instance by assigning a VRF name and enters VRF configuration mode. <ul style="list-style-type: none"> The <i>vrf-name</i> argument is the name assigned to a VRF.
Step 4	rd <i>route-distinguisher</i> Example: Router(config-vrf)# rd 100:1	Creates routing and forwarding tables. <ul style="list-style-type: none"> The <i>route-distinguisher</i> argument adds an 8-byte value to an IPv4 prefix to create a VPN IPv4 prefix. You can enter an RD in either of these formats: <ul style="list-style-type: none"> 16-bit autonomous system number: your 32-bit number, for example, 101:3 32-bit IP address: your 16-bit number, for example, 192.168.122.15:1
Step 5	address-family ipv4 Example: Router(config-vrf)# address-family ipv4	Enters VRF address family configuration mode to specify an address family for a VRF. <ul style="list-style-type: none"> The ipv4 keyword specifies an IPv4 address family for a VRF.
Step 6	route-target { import export both } <i>route-target-ext-community</i> Example: Router(config-vrf-af)# route-target import 100:1	Creates a route-target extended community for a VRF. <ul style="list-style-type: none"> The import keyword imports routing information from the target VPN extended community. The export keyword exports routing information to the target VPN extended community. The both keyword imports routing information from and exports routing information to the target VPN extended community. The <i>route-target-ext-community</i> argument adds the route-target extended community attributes to the VRF list of import, export, or both (import and export) route-target extended communities.
Step 7	For Inter-AS Option AB+, go to Step 10; otherwise, go to Step 8.	—
Step 8	inter-as-hybrid [csc] Example: Router(config-vrf-af)# inter-as-hybrid	Specifies the VRF as an Option AB VRF, which has the following effects: <ul style="list-style-type: none"> Routes imported to this VRF can be advertised to Option AB peers and VPNv4 iBGP peers.

	Command or Action	Purpose
		<ul style="list-style-type: none"> When routes received from Option AB peers and are imported into the VRF, the next hop table ID of the route is set to the table ID of the VRF. If the csc keyword is not used, a per-VRF label is allocated for imported routes. When routes are received from Option AB peers and are imported next into the VRF, the learned out label can be installed only in forwarding when the csc keyword is used. <p>The csc keyword implies the following:</p> <ul style="list-style-type: none"> A per-prefix label is allocated for imported routes. For routes received from Option AB peers that are imported into the VRF, the learned out label is installed in forwarding.
Step 9	<p>inter-as-hybrid [csc] [next-hop ip-address]</p> <p>Example:</p> <pre>Router(config-vrf-af)# inter-as-hybrid next-hop 192.168.1.0</pre>	<p>(Optional) Specifies the next hop IP address to be set on paths that are imported into the VRF and that are received from an Option AB peer.</p> <ul style="list-style-type: none"> The next hop context is also set to the VRF, which imports these paths. The csc keyword implies the following: <ul style="list-style-type: none"> A per-prefix label is allocated for imported routes. For routes received from Option AB peers that are imported into the VRF, the learned out label is installed in forwarding.
Step 10	<p>inter-as-hybrid next-hop global</p> <p>Example:</p> <pre>Router(config-vrf-af)# inter-as-hybrid next-hop global</pre>	<p>(For Option AB+) Enables Inter-AS Option AB+.</p> <ul style="list-style-type: none"> Specifies that the next-hop address for BGP updates to be set on paths that are imported to the VRF and that are received from an Option AB+ peer are placed in the global routing table. The address used is the address of the interface that is at the remote end of the external BGP (eBGP) global shared link. The next-hop context is retained as global and not modified to that of the importing VRF.
Step 11	<p>end</p> <p>Example:</p> <pre>Router(config-vrf-af)# end</pre>	<p>(Optional) Exits to privileged EXEC mode.</p>

Changing an Inter-AS Option A Deployment to an Option AB Deployment

In an Option A deployment, the VRF instances are back-to-back between the ASBR routers and there is direct connectivity between PE routers of different autonomous systems. The PE routers are attached by multiple physical or logical interfaces, each of which is associated with a given VPN (through a VRF instance).

In the Option AB deployment, the different autonomous systems interconnect by using a single MP-BGP session in the global routing table to carry control plane traffic.

Use the following steps to change an MPLS VPN Inter-AS Option A deployment to an Option AB deployment.

1. Configure the MP-BGP session on the ASBR. BGP multiprotocol extensions are used to define support for address families other than IPv4 so that the routes for a given VPN are learned only by other members of that VPN, enabling members of the VPN to communicate with each other. See the [Configuring the MP-BGP Session Between ASBR Peers, on page 12](#) for detailed configuration information.
2. Identify the VRFs that need an upgrade from Option A and configure them for Option AB by using the **inter-as-hybrid** command. See the [Configuring the Routing Policy for VPNs that Need Inter-AS Connections, on page 14](#) for detailed configuration information.
3. Use the following steps in this section to remove the configuration for the eBGP (peer ASBR) neighbor.
4. Repeat all the steps in the following procedure to remove the configuration for additional eBGP (peer ASBR) neighbors.

SUMMARY STEPS

1. **enable**
2. **configure terminal**
3. **router bgp** *as-number*
4. **address-family ipv4 vrf** *vrf-name*
5. **no neighbor** *{ip-address | peer-group-name}*
6. **exit-address-family**
7. **end**

DETAILED STEPS

	Command or Action	Purpose
Step 1	enable Example: Router> enable	Enables privileged EXEC mode. <ul style="list-style-type: none"> • Enter your password if prompted.
Step 2	configure terminal Example: Router# configure terminal	Enters global configuration mode.
Step 3	router bgp <i>as-number</i> Example:	Configures a BGP routing process and places the router in router configuration mode.

	Command or Action	Purpose
	<pre>Router(config)# router bgp 100</pre>	<ul style="list-style-type: none"> The <i>as-number</i> argument indicates the number of an autonomous system that identifies the router to other BGP routers and tags the routing information passed along. Valid numbers are from 0 to 65535. Private autonomous system numbers that can be used in internal networks range from 64512 to 65535.
Step 4	<p>address-family ipv4 vrf vrf-name</p> <p>Example:</p> <pre>Router(config-router)# address-family ipv4 vrf vpn4</pre>	<p>Configures each VRF that is identified in the MP-BGP session on the ASBR so that the routes for a given VPN are learned only by other members of that VPN, enabling members of the VPN to communicate with each other.</p> <ul style="list-style-type: none"> Enters address family configuration mode to specify an address family for a VRF.
Step 5	<p>no neighbor {ip-address peer-group-name}</p> <p>Example:</p> <pre>Router(config-router-af)# no neighbor 192.168.0.1</pre>	<p>Removes the configuration for the exchange of information with the neighboring eBGP (ASBR) router.</p> <ul style="list-style-type: none"> The <i>ip-address</i> argument specifies the IP address of the neighbor. The <i>peer-group-name</i> argument specifies the name of a BGP peer group.
Step 6	<p>exit-address-family</p> <p>Example:</p> <pre>Router(config-router-af)# exit-address-family</pre>	<p>Exits from address family configuration mode.</p>
Step 7	<p>end</p> <p>Example:</p> <pre>Router(config-router-af)# end</pre>	<p>(Optional) Exits to privileged EXEC mode.</p>

Configuration Examples for MPLS VPN--Inter-AS Option AB

The following sections describe standard and CSC MPLS VPN configurations between two ASBR peers that use the Inter-AS AB feature:

Examples Inter-AS AB Network Configuration

The following examples show the configuration of an Inter-AS Option AB network that uses nonoverlapping IP addresses:

Example CE1

```
!  
ip cef distributed  
!  
interface lo0  
  ip address 192.168.13.13 255.255.255.255  
  no shutdown  
!  
interface et4/0  
  ip address 192.168.36.1 255.255.255.0  
  no shutdown  
!  
router ospf 300  
  nsf enforce global  
  redistribute connected subnets  
  auto-cost reference-bandwidth 1000  
  passive-interface et4/0  
  network 192.168.13.13 0.0.0.0 area 300  
!  
router bgp 300  
  bgp graceful-restart restart-time 120  
  bgp graceful-restart stalepath-time 360  
  bgp graceful-restart  
  no synchronization  
  neighbor 192.168.36.2 remote-as 100  
  neighbor 192.168.36.2 advertisement-interval 5  
  address-family ipv4 no auto-summary  
  redistribute connected  
  neighbor 192.168.36.2 activate
```

Example CE2

```
!  
ip cef distributed  
!  
interface lo0  
  ip address 192.168.14.14 255.255.255.255  
  no shutdown  
!  
interface et1/6  
  ip address 192.168.37.1 255.255.255.0  
  no ipv6 address  
  no shutdown  
!  
router ospf 400  
  nsf enforce global  
  redistribute connected subnets  
  auto-cost reference-bandwidth 1000  
  passive-interface et1/6  
  network 192.168.14.14 0.0.0.0 area 400  
!  
router bgp 400  
  bgp graceful-restart restart-time 120  
  bgp graceful-restart stalepath-time 360  
  bgp graceful-restart  
  no synchronization  
  neighbor 192.168.0.2 remote-as 100  
  neighbor 192.168.0.2 advertisement-interval 5  
  address-family ipv4 no auto-summary  
  redistribute connected
```

```
neighbor 192.168.0.2 activate
!
```

Example PE1

```
!
ip cef distributed
!
ip vrf vpn1
  rd 100:1
  route-target import 100:1
  route-target import 200:1
  route-target export 100:1
!
ip vrf vpn2
  rd 100:2
  route-target import 100:2
  route-target import 200:2
  route-target export 100:2
!
mpls ldp router-id lo0 force
mpls ldp graceful-restart
mpls ip
mpls ip propagate-ttl
mpls ldp advertise-labels
mpls label protocol ldp
!
interface lo0
  ip address 192.168.17.17 255.255.255.255
  no shutdown
!
interface gi3/1
  ip vrf forwarding vpn1
  ip address 192.168.36.2 255.255.255.0
  no shutdown
!
interface gi3/8
  mpls ip
  mpls label protocol ldp
  ip address 192.168.31.2 255.255.255.0
!
interface gi3/10
  mpls ip
  mpls label protocol ldp
  ip address 192.168.40.1 255.255.255.0
  no shutdown
!
interface gi3/13
  ip vrf forwarding vpn2
  ip address 192.168.0.2 255.0.0.0
  no shutdown
!
router ospf 100
  nsf enforce global
  redistribute connected subnets
  auto-cost reference-bandwidth 1000
  passive-interface gi3/1
  passive-interface gi3/13
  network 192.168.0.0 0.0.255.255 area 10
  network 192.168.17.17 0.0.0.0 area 100
  network 192.168.0.0 0.0.255.255 area 100
!
router bgp 100
```

```

bgp graceful-restart restart-time 120
bgp graceful-restart stalepath-time 360
bgp graceful-restart
no bgp default ipv4-unicast
no synchronization
neighbor 192.168.19.19 remote-as 100
neighbor 192.168.19.19 update-source Loopback0
address-family ipv4 vrf vpn1
no auto-summary
redistribute connected
neighbor 192.168.36.1 remote-as 300
neighbor 192.168.36.1 activate
neighbor 192.168.36.1 advertisement-interval 5
address-family ipv4 vrf vpn2 no auto-summary
redistribute connected
neighbor 192.168.37.1 remote-as 400
neighbor 192.168.37.1 activate
neighbor 192.168.37.1 advertisement-interval 5
address-family vpnv4
bgp scan-time import 5
neighbor 192.168.19.19 activate
neighbor 192.168.19.19 send-community extended
!
```

Example Route Reflector 1

```

!
ip cef distributed
mpls ldp router-id lo0 force
mpls ldp graceful-restart
mpls ip
mpls ip propagate-ttl
mpls ldp advertise-labels
mpls ip
mpls label protocol ldp
!
interface lo0
ip address 192.168.19.19 255.255.255.255
no shutdown
!
interface gi3/3
mpls ip
mpls label protocol ldp
ip address 192.168.40.2 255.255.255.0
no shutdown
!
router ospf 100
nsf enforce global
redistribute connected subnets
auto-cost reference-bandwidth 1000
network 192.168.19.19 0.0.0.0 area 100
network 192.168.0.0 0.0.255.255 area 100 !
router bgp 100
bgp graceful-restart restart-time 120
bgp graceful-restart stalepath-time 360
bgp graceful-restart
neighbor 192.168.11.11 remote-as 100
neighbor 192.168.11.11 update-source Loopback0
neighbor 192.168.17.17 remote-as 100
neighbor 192.168.17.17 update-source Loopback0
neighbor 192.168.11.11 route-reflector-client
address-family ipv4
no neighbor 192.168.17.17 activate
```

Example ASBR1

```

neighbor 192.168.11.11 route-reflector-client
address-family vpnv4
  bgp scan-time import 5
neighbor 192.168.11.11 activate
neighbor 192.168.11.11 send-community extended
neighbor 192.168.17.17 activate
neighbor 192.168.17.17 send-community extended
neighbor 192.168.11.11 route-reflector-client
neighbor 192.168.17.17 route-reflector-client
!
```

Example ASBR1

```

!
ip cef distributed
!
ip vrf vpn1
  rd 100:1
  route-target import 100:1
  route-target import 200:1
  route-target export 100:1
  inter-as-hybrid next-hop 192.168.32.2
exit
ip vrf vpn2
  rd 100:2
  route-target import 100:2
  route-target import 200:2
  route-target export 100:2
  inter-as-hybrid next-hop 192.168.33.2
exit
mpls ldp router-id lo0 force
mpls ldp graceful-restart
mpls ip
mpls ip propagate-ttl
mpls ldp advertise-labels
  mpls ip
  mpls label protocol ldp
interface lo0
  ip address 192.168.11.11 255.255.255.255
  no ipv6 address
ip route-cache distributed
ip route-cache cef distributed
no shutdown
interface gi3/8
mpls ip
  mpls label protocol ldp
  ip address 192.168.13.1 255.255.255.0
  no ipv6 address
ip route-cache distributed
ip route-cache cef distributed
no shutdown
interface gi3/10
  ip vrf forwarding vpn1
  ip address 192.168.32.1 255.255.255.0
  no ipv6 address
ip route-cache distributed
ip route-cache cef distributed
no shutdown
interface gi3/11
  ip vrf forwarding vpn2
  ip address 192.168.33.1 255.255.255.0
  no ipv6 address
ip route-cache distributed
```

```

ip route-cache cef distributed
no shutdown
interface gi3/46
 ip address 192.168.34.1 255.255.255.0
 no ipv6 address
ip route-cache distributed
ip route-cache cef distributed
no shutdown
router ospf 100
nsf enforce global
 redistribute connected subnets
auto-cost reference-bandwidth 1000
passive-interface gi3/10
passive-interface gi3/11
passive-interface gi3/46
network 192.168.0.0 0.0.255.255 area 100
network 192.168.11.11 0.0.0.0 area 100

router bgp 100
 bgp graceful-restart restart-time 120
 bgp graceful-restart stalepath-time 360
 bgp graceful-restart
 no synchronization
 no bgp default route-target filter
 bgp router-id 192.168.11.11
 neighbor 192.168.34.2 remote-as 200
 neighbor 192.168.34.2 advertisement-interval 5
 neighbor 192.168.19.19 remote-as 100
 neighbor 192.168.19.19 update-source Loopback0
 address-family ipv4
  no auto-summary
 address-family ipv4 vrf vpn1
  no auto-summary
 address-family ipv4 vrf vpn2
  no auto-summary
 address-family vpnv4
  bgp scan-time import 5
  neighbor 192.168.34.2 activate
  neighbor 192.168.34.2 send-community both
  neighbor 192.168.34.2 inter-as-hybrid
  neighbor 192.168.19.19 activate
  neighbor 192.168.19.19 send-community extended !
ip route vrf vpn1 192.168.12.12 255.255.255.255 gi3/10 192.168.32.2
ip route vrf vpn2 192.168.12.12 255.255.255.255 gi3/11 192.168.33.2
!
```

Example ASBR 3

```

!
ip cef distributed
!
ip vrf vpn1
 rd 200:1
  route-target import 100:1
  route-target import 200:1
  route-target export 200:1
  inter-as-hybrid next-hop 192.168.32.1
!
ip vrf vpn2
 rd 200:2
  route-target import 100:2
  route-target import 200:2
  route-target export 200:2
```

```

        inter-as-hybrid next-hop 192.168.33.1
    !
    mpls ldp router-id lo0 force
    mpls ldp graceful-restart
    mpls ip
    mpls ip propagate-ttl
    mpls ldp advertise-labels
    mpls label protocol ldp
    !
    interface lo0
        ip address 192.168.12.12 255.255.255.255
        no shutdown
    !
    interface po2/1/0
        mpls ip
        mpls label protocol ldp
        ip address 192.168.35.1 255.255.255.0
        crc 16
        clock source internal
        no shutdown
    !
    interface gi3/10
        ip vrf forwarding vpn1
        ip address 192.168.32.2 255.255.255.0
        no shutdown
    !
    interface gi3/11
        ip vrf forwarding vpn2
        ip address 192.168.33.2 255.255.255.0
        no shutdown
    !
    interface gi3/45
        ip address 192.168.34.2 255.255.255.0
        no shutdown
    !
    router ospf 200
        nsf enforce global
        redistribute connected subnets
        auto-cost reference-bandwidth 1000
        passive-interface gi3/10
        passive-interface gi3/11
        passive-interface gi3/45
        network 192.168.0.0 0.0.255.255 area 200 network 192.168.12.12 0.0.0.0 area 200

    router bgp 200
        bgp graceful-restart restart-time 120
        bgp graceful-restart stalepath-time 360
        bgp graceful-restart
        no synchronization
        no bgp default route-target filter
        bgp router-id 192.168.12.12
        neighbor 192.168.34.1 remote-as 100
        neighbor 192.168.34.1 advertisement-interval 5
        neighbor 192.168.20.20 remote-as 200
        neighbor 192.168.20.20 update-source Loopback0
        address-family ipv4
        no auto-summary
        address-family ipv4 vrf vpn1
        no auto-summary
        address-family ipv4 vrf vpn2
        no auto-summary
        address-family vpnv4
        bgp scan-time import 5
        neighbor 192.168.34.1 activate

```



```

neighbor 192.168.34.1 send-community both
neighbor 192.168.34.1 inter-as-hybrid
neighbor 192.168.20.20 activate
neighbor 192.168.20.20 send-community extended !
ip route vrf vpn1 192.168.11.11 255.255.255.255 gi3/10 192.168.32.1
ip route vrf vpn2 192.168.11.11 255.255.255.255 gi3/11 192.168.33.1
!
```

Example PE2

```

!
ip cef distributed
!
ip vrf vpn1
  rd 200:1
  route-target import 100:1
  route-target import 200:1
  route-target export 200:1
!
ip vrf vpn2
  rd 200:2
  route-target import 100:2
  route-target import 200:2
  route-target export 200:2
!
mpls ldp router-id lo0 force
mpls ldp graceful-restart
mpls ip
mpls ip propagate-ttl
mpls ldp advertise-labels
mpls label protocol ldp
!
interface lo0
  ip address 192.168.18.18 255.255.255.255
  no shutdown
!
interface po1/0/0
  mpls ip
  mpls label protocol ldp
  ip address 192.168.35.2 255.255.255.0
  crc 16
  clock source internal
  no shutdown
!
interface gi3/2
  ip vrf forwarding vpn1
  ip address 192.168.38.2 255.255.255.0
  no shutdown
!
interface gi3/8
  mpls ip
  mpls label protocol ldp
  ip address 192.168.4.1 255.255.255.0
  no shutdown
!
interface gi3/10
  ip vrf forwarding vpn2
  ip address 192.168.39.2 255.255.255.0
  no shutdown
!
router ospf 200
  nsf enforce global
  redistribute connected subnets
```

Example CE3

```

auto-cost reference-bandwidth 1000
passive-interface gi3/10
passive-interface gi3/2
network 192.168.0.0 0.0.255.255 area 200
network 192.168.18.18 0.0.0.0 area 200
network 192.168.0.0 0.0.255.255 area 200 !
router bgp 200
  bgp graceful-restart restart-time 120
  bgp graceful-restart stalepath-time 360
  bgp graceful-restart
  no bgp default ipv4-unicast
  no synchronization
  neighbor 192.168.20.20 remote-as 200
  neighbor 192.168.20.20 update-source Loopback0
  address-family ipv4 vrf vpn1
    no auto-summary
    redistribute connected
    neighbor 192.168.38.1 remote-as 500
    neighbor 192.168.38.1 activate
    neighbor 192.168.38.1 advertisement-interval 5
  address-family ipv4 vrf vpn2
    no auto-summary
    redistribute connected
    neighbor 192.168.9.1 remote-as 600
    neighbor 192.168.9.1 activate
    neighbor 192.168.9.1 advertisement-interval 5
  address-family vpnv4
    bgp scan-time import 5
    neighbor 192.168.20.20 activate
    neighbor 192.168.20.20 send-community extended
!

```

Example CE3

```

!
ip cef distributed
!
interface lo0
  ip address 192.168.15.15 255.255.255.255
  no shutdown
!
interface gi0/2
  ip address 192.168.38.1 255.255.255.0
  no shutdown
!
router ospf 500
  nsf enforce global
  redistribute connected subnets
  auto-cost reference-bandwidth 1000
  passive-interface gi0/2
  network 192.168.15.15 0.0.0.0 area 500
!
router bgp 500
  bgp graceful-restart restart-time 120
  bgp graceful-restart stalepath-time 360
  bgp graceful-restart
  no synchronization
  neighbor 192.168.38.2 remote-as 200
  neighbor 192.168.38.2 advertisement-interval 5
  address-family ipv4
  no auto-summary
  redistribute connected

```

```
neighbor 192.168.38.2 activate
!
```

Example CE4

```
!
ip cef distributed
!
interface lo0
 ip address 192.168.16.16 255.255.255.255
 no shutdown
!
interface et6/2
 ip address 192.168.9.1 255.255.255.0
 no shutdown
!
router ospf 600
 nsf enforce global
 redistribute connected subnets
 auto-cost reference-bandwidth 1000
 passive-interface et6/2
 network 192.168.16.16 0.0.0.0 area 600
!
router bgp 600
 bgp graceful-restart restart-time 120
 bgp graceful-restart stalepath-time 360
 bgp graceful-restart
 no synchronization
 neighbor 192.168.39.2 remote-as 200
 neighbor 192.168.39.2 advertisement-interval 5
 address-family ipv4 no auto-summary
 redistribute connected
 neighbor 192.168.39.2 activate
!
```

Examples Inter-AS AB CSC Configuration

The following examples show the configuration of an Inter-AS Option AB network with CSC:

Example CE1

```
!
ip cef distributed
!
interface Loopback0
 ip address 192.168.20.20 255.255.255.255
!
interface Ethernet3/3
 ip address 192.168.41.2 255.255.255.0
!
!
router bgp 500
 bgp router-id 192.168.20.20
 bgp log-neighbor-changes
 bgp graceful-restart restart-time 120
 bgp graceful-restart stalepath-time 360
 bgp graceful-restart
 neighbor 192.168.4.1 remote-as 300
!
```

Example CE2

```

address-family ipv4
 redistribute connected
 neighbor 192.168.4.1 activate
 neighbor 192.168.4.1 advertisement-interval 5
 no auto-summary
 no synchronization
 exit-address-family
!
```

Example CE2

```

!
ip cef distributed
!
interface Loopback0
 ip address 192.168.21.21 255.255.255.255
!
interface Ethernet0/0/7
 ip address 192.168.42.2 255.255.255.0
!
router bgp 600
 bgp log-neighbor-changes
 bgp graceful-restart restart-time 120
 bgp graceful-restart stalepath-time 360
 bgp graceful-restart neighbor 192.168.42.1 remote-as 400
!
address-family ipv4
 redistribute connected
 neighbor 192.168.42.1 activate
 neighbor 192.168.42.1 advertisement-interval 5
 no auto-summary
 no synchronization
 exit-address-family
!
```

Example CE3

```

!
ip cef distributed
!
interface Loopback0
 ip address 192.168.22.22 255.255.255.255
!
interface Ethernet6/2
 ip address 192.168.43.2 255.255.255.0
!
router bgp 500
 bgp log-neighbor-changes
 bgp graceful-restart restart-time 120
 bgp graceful-restart stalepath-time 360
 bgp graceful-restart neighbor 192.168.43.1 remote-as 300
!
address-family ipv4
 redistribute connected
 neighbor 192.168.43.1 activate
 neighbor 192.168.43.1 advertisement-interval 5
 no auto-summary
 no synchronization
 exit-address-family
!
```

Example CE4

```

!
ip cef distributed
!
interface Loopback0
 ip address 192.168.23.23 255.255.255.255
!
!
interface Ethernet0/0/7
 ip address 192.168.44.2 255.255.255.0
!
router bgp 600
 bgp router-id 192.168.23.23
 bgp log-neighbor-changes
 bgp graceful-restart restart-time 120
 bgp graceful-restart stalepath-time 360
 bgp graceful-restart
 neighbor 192.168.44.1 remote-as 400
!
 address-family ipv4
  redistribute connected
  neighbor 192.168.44.1 activate
  neighbor 192.168.44.1 advertisement-interval 5
  no auto-summary
  no synchronization
 exit-address-family
!

```

Example PE1

```

!
ip cef distributed
!
ip vrf vpn3
 rd 300:3
 route-target export 300:3
 route-target import 300:3
!
mpls ldp graceful-restart
!
mpls label protocol ldp
!
mpls ip
!
interface Loopback0
 ip address 192.168.192.10 255.255.255.255
!
interface Ethernet3/1
 ip vrf forwarding vpn3
 ip address 192.168.4.1 255.255.255.0
!
interface Ethernet5/3
 ip address 192.168.3.1 255.255.255.0
 mpls label protocol ldp
 mpls ip
!
!
router ospf 300
 log-adjacency-changes
 auto-cost reference-bandwidth 1000

```

```

redistribute connected subnets
network 192.168.192.10 0.0.0.0 area 300
network 192.168.0.0 0.0.255.255 area 300
!
router bgp 300
no bgp default ipv4-unicast
bgp log-neighbor-changes
bgp graceful-restart restart-time 120
bgp graceful-restart stalepath-time 360
bgp graceful-restart
neighbor 192.168.19.19 remote-as 300
neighbor 192.168.19.19 update-source Loopback0
!
address-family vpnv4
neighbor 192.168.19.19 activate
neighbor 192.168.19.19 send-community extended
bgp scan-time import 5
exit-address-family
!
address-family ipv4 vrf vpn3
redistribute connected
neighbor 192.168.41.2 remote-as 500
neighbor 192.168.41.2 activate
neighbor 192.168.41.2 as-override
neighbor 192.168.41.2 advertisement-interval 5
no auto-summary
no synchronization
exit-address-family
!

```

Example CSC-CE1

```

!
ip cef distributed
!
mpls ldp graceful-restart
mpls label protocol ldp
!
mpls ip
!
interface Loopback0
ip address 192.168.11.11 255.255.255.255
!
!
interface Ethernet3/4
ip address 192.168.30.2 255.255.255.0
mpls label protocol ldp
mpls ip
!
router ospf 300
log-adjacency-changes
auto-cost reference-bandwidth 1000
redistribute connected subnets
redistribute bgp 300 metric 3 subnets
passive-interface FastEthernet1/0
network 192.168.11.11 0.0.0.0 area 300
network 192.168.0.0 0.0.255.255 area 300
distance ospf intra-area 19 inter-area 19
!
router bgp 300
bgp router-id 192.168.11.11
no bgp default ipv4-unicast
bgp log-neighbor-changes

```

```

bgp graceful-restart restart-time 120
bgp graceful-restart stalepath-time 360
bgp graceful-restart
neighbor 192.168.13.1 remote-as 100
!
address-family ipv4
 redistribute ospf 300 metric 4 match internal external 1 external 2
 neighbor 192.168.13.1 activate
 neighbor 192.168.13.1 send-label
 no auto-summary
 no synchronization
 exit-address-family
!
```

Example CSC-PE1

```

!
ip vrf vpn1
 rd 100:1
 route-target export 100:1
 route-target import 100:1
 route-target import 100:5
 route-target import 200:1
!
ip vrf vpn2
 rd 100:2
 route-target export 100:2
 route-target import 100:2
 route-target import 100:6
 route-target import 200:2
!
mpls ldp graceful-restart
mpls label protocol ldp
!
mpls ip
!
interface Loopback0
 ip address 192.168.12.12 255.255.255.255
!
!
interface FastEthernet4/0/0
 ip address 192.168.34.1 255.255.255.0
 mpls label protocol ldp
 mpls ip
!
interface FastEthernet4/0/1
 ip vrf forwarding vpn1
 ip address 192.168.13.1 255.255.255.0
 mpls bgp forwarding
!
!
interface FastEthernet4/1/0
 ip vrf forwarding vpn2
 ip address 192.168.33.1 255.255.255.0
 mpls bgp forwarding
!
router ospf 100
 log-adjacency-changes
 auto-cost reference-bandwidth 1000
 nsf enforce global
 redistribute connected subnets
 network 192.168.12.12 0.0.0.0 area 100
 network 192.168.0.0 0.0.255.255 area 100
```

Example PE 2

```

!
router bgp 100
  bgp router-id 192.168.12.12
  no bgp default ipv4-unicast
  bgp log-neighbor-changes
  bgp graceful-restart restart-time 120
  bgp graceful-restart stalepath-time 360
  bgp graceful-restart
  neighbor 192.168.15.15 remote-as 100
  neighbor 192.168.15.15 update-source Loopback0
  !
  address-family vpnv4
    neighbor 192.168.15.15 activate
    neighbor 192.168.15.15 send-community extended
    bgp scan-time import 5
  exit-address-family
  !
  address-family ipv4 vrf vpn2
    neighbor 192.168.33.2 remote-as 400
    neighbor 192.168.33.2 update-source FastEthernet4/1/0
    neighbor 192.168.33.2 activate
    neighbor 192.168.33.2 as-override
    neighbor 192.168.33.2 advertisement-interval 5
    neighbor 192.168.33.2 send-label
    no auto-summary
    no synchronization
  exit-address-family
  !
  address-family ipv4 vrf vpn1
    neighbor 192.168.31.2 remote-as 300
    neighbor 192.168.31.2 update-source FastEthernet4/0/1
    neighbor 192.168.31.2 activate
    neighbor 192.168.31.2 as-override
    neighbor 192.168.31.2 advertisement-interval 5
    neighbor 192.168.31.2 send-label
    no auto-summary
    no synchronization
  exit-address-family
  !

```

Example PE 2

```

ip cef distributed
!
ip vrf vpn4
  rd 400:4
  route-target export 400:4
  route-target import 400:4
!
!
mpls ldp graceful-restart
mpls label protocol ldp
!
mpls ip
!
interface Loopback0
  ip address 192.168.13.13 255.255.255.255
!
!
interface Ethernet4/1/2
  ip vrf forwarding vpn4
  ip address 192.168.42.1 255.255.255.0
!

```



```

!
interface Ethernet4/1/6
 ip address 192.168.32.1 255.255.255.0
 mpls label protocol ldp
 mpls ip
!
!
router ospf 400
 log-adjacency-changes
 auto-cost reference-bandwidth 1000
 nsf enforce global
 redistribute connected subnets
 network 192.168.13.13 0.0.0.0 area 400
 network 192.168.0.0 0.0.255.255 area 400
!
router bgp 400
 bgp router-id 192.168.13.13
 no bgp default ipv4-unicast
 bgp log-neighbor-changes
 bgp graceful-restart restart-time 120
 bgp graceful-restart stalepath-time 360
 bgp graceful-restart
 neighbor 192.168.25.25 remote-as 400
 neighbor 192.168.25.25 update-source Loopback0
!
 address-family vpnv4
  neighbor 192.168.25.25 activate
  neighbor 192.168.25.25 send-community extended
  bgp scan-time import 5
 exit-address-family
!
 address-family ipv4 vrf vpn4
  redistribute connected
  neighbor 192.168.42.2 remote-as 600
  neighbor 192.168.42.2 activate
  neighbor 192.168.42.2 as-override
  neighbor 192.168.42.2 advertisement-interval 5
  no auto-summary
  no synchronization
 exit-address-family
!

```

Example CSC-CE2

```

!
ip cef distributed
!
mpls ldp graceful-restart
mpls label protocol ldp
!
mpls ip
interface Loopback0
 ip address 192.168.14.14 255.255.255.255
!
!
interface GigabitEthernet8/16
 ip address 192.168.33.2 255.255.255.0
 mpls bgp forwarding
!
!
interface GigabitEthernet8/24
 ip address 192.168.32.2 255.255.255.0
 mpls label protocol ldp

```

Example ASBR1

```

mpls ip
!
!
router ospf 400
  log-adjacency-changes
  auto-cost reference-bandwidth 1000
  nsf enforce global
  redistribute connected subnets
  redistribute bgp 400 metric 3 subnets
  passive-interface GigabitEthernet8/16
  network 192.168.14.14 0.0.0.0 area 400
  network 192.168.0.0 0.0.255.255 area 400
  distance ospf intra-area 19 inter-area 19
!
router bgp 400
  bgp router-id 192.168.14.14
  no bgp default ipv4-unicast
  bgp log-neighbor-changes
  bgp graceful-restart restart-time 120
  bgp graceful-restart stalepath-time 360
  bgp graceful-restart
  neighbor 192.168.33.1 remote-as 100
!
  address-family ipv4
    no synchronization
    redistribute connected
    redistribute ospf 400 metric 4 match internal external 1 external 2
    neighbor 192.168.33.1 activate
    neighbor 192.168.33.1 advertisement-interval 5
    neighbor 192.168.33.1 send-label
    no auto-summary
  exit-address-family
!

```

Example ASBR1

```

!
ip vrf vpn5
  rd 100:5
  route-target export 100:5
  route-target import 100:5
  route-target import 100:1
  route-target import 200:5
  inter-as-hybrid csc next-hop 192.168.35.2
!
ip vrf vpn6
  rd 100:6
  route-target export 100:6
  route-target import 100:6
  route-target import 100:2
  route-target import 200:6
  inter-as-hybrid csc next-hop 192.168.36.2
!
mpls ldp graceful-restart
mpls label protocol ldp
!
!
interface Loopback0
  ip address 192.168.15.15 255.255.255.255
!
interface GigabitEthernet2/3
  ip vrf forwarding vpn5
  ip address 192.168.35.1 255.255.255.0

```

```

mpls bgp forwarding
!
interface GigabitEthernet2/4
 ip vrf forwarding vpn6
 ip address 192.168.36.1 255.255.255.0
 mpls bgp forwarding
!
!
interface GigabitEthernet2/5
 ip address 192.168.34.2 255.255.255.0
 mpls label protocol ldp
 mpls ip
!
!
interface GigabitEthernet2/16
 ip address 192.168.37.1 255.255.255.0
 mpls bgp forwarding
!
!
router ospf 100
 log-adjacency-changes
 auto-cost reference-bandwidth 1000
 nsf enforce global
 redistribute connected subnets
 network 192.168.15.15 0.0.0.0 area 100
 network 192.168.0.0 0.0.255.255 area 100
!
router bgp 100
 bgp router-id 192.168.15.15
 no bgp default ipv4-unicast
 no bgp default route-target filter
 bgp log-neighbor-changes
 bgp graceful-restart restart-time 120
 bgp graceful-restart stalepath-time 360
 bgp graceful-restart
 neighbor 192.168.12.12 remote-as 100
 neighbor 192.168.12.12 update-source Loopback0
 neighbor 192.168.0.2 remote-as 200
 neighbor 192.168.0.2 disable-connected-check
!
 address-family ipv4
  no synchronization
  no auto-summary
 exit-address-family
!
 address-family vpnv4
  neighbor 192.168.12.12 activate
  neighbor 192.168.12.12 send-community extended
  neighbor 192.168.0.2 activate
  neighbor 192.168.0.2 send-community extended
  neighbor 192.168.0.2 inter-as-hybrid
 exit-address-family
!
 address-family ipv4 vrf vpn5
  no synchronization
 exit-address-family
!
 address-family ipv4 vrf vpn6
  no synchronization
 exit-address-family
!
ip route 192.168.16.16 255.255.255.255 GigabitEthernet2/16 192.168.0.2
ip route vrf vpn5 192.168.16.16 255.255.255.255 GigabitEthernet2/3 192.168.35.2
ip route vrf vpn6 192.168.16.16 255.255.255.255 GigabitEthernet2/4 192.168.36.2

```

```

!
ip vrf vpn5
 rd 200:5
  route-target export 200:5
  route-target import 200:5
  route-target import 200:1
  route-target import 100:1
  route-target import 100:5
  inter-as-hybrid csc next-hop 192.168.35.1
!
ip vrf vpn6
 rd 200:6
  route-target export 200:6
  route-target import 200:6
  route-target import 200:2
  route-target import 100:2
  route-target import 100:6
  inter-as-hybrid csc next-hop 192.168.36.1
!
mpls ldp graceful-restart
mpls label protocol ldp
!
!
interface Loopback0
 ip address 192.168.16.16 255.255.255.255
!
!
interface GigabitEthernet3/1
 ip vrf forwarding vpn5
 ip address 192.168.35.2 255.255.255.0
 mpls bgp forwarding
!
interface GigabitEthernet3/2
 ip vrf forwarding vpn6
 ip address 192.168.36.2 255.255.255.0
 mpls bgp forwarding
!
!
interface GigabitEthernet3/14
 ip address 192.168.0.2 255.0.0.0
 mpls bgp forwarding
!
interface GigabitEthernet3/15
 ip address 192.168.38.2 255.255.255.0
 mpls label protocol ldp
 mpls ip
!
router ospf 200
 log-adjacency-changes
 auto-cost reference-bandwidth 1000
 nsf enforce global
 redistribute connected subnets
 network 192.168.16.16 0.0.0.0 area 200
 network 192.168.0.0 0.0.255.255 area 200
!
router bgp 200
 bgp router-id 192.168.16.16
 no bgp default ipv4-unicast
 no bgp default route-target filter
 bgp log-neighbor-changes
 bgp graceful-restart restart-time 120
 bgp graceful-restart stalepath-time 360
 bgp graceful-restart
 neighbor 192.168.17.17 remote-as 200
 neighbor 192.168.17.17 update-source Loopback0

```

```

neighbor 192.168.37.1 remote-as 100
neighbor 192.168.37.1 disable-connected-check
!
address-family ipv4
  no synchronization
  no auto-summary
exit-address-family
!
address-family vpnv4
  neighbor 192.168.17.17 activate
  neighbor 192.168.17.17 send-community extended
  neighbor 192.168.37.1 activate
  neighbor 192.168.37.1 send-community extended
  neighbor 192.168.37.1 inter-as-hybrid
exit-address-family
!
address-family ipv4 vrf vpn5
  no synchronization
exit-address-family
!
address-family ipv4 vrf vpn6
  no synchronization
exit-address-family
!
ip route 192.168.15.15 255.255.255.255 GigabitEthernet3/14 192.168.37.1
ip route vrf vpn5 192.168.15.15 255.255.255.255 GigabitEthernet3/1 192.168.35.1
ip route vrf vpn6 192.168.15.15 255.255.255.255 GigabitEthernet3/2 192.168.36.1
!

```

Example CSC-PE 3

```

ip vrf vpn1
  rd 200:1
  route-target export 200:1
  route-target import 200:1
  route-target import 200:5
  route-target import 100:1
!
ip vrf vpn2
  rd 200:2
  route-target export 200:2
  route-target import 200:2
  route-target import 200:6
  route-target import 100:2
!
mpls ldp graceful-restart
mpls label protocol ldp
!
mpls ip
!
interface Loopback0
  ip address 192.168.17.17 255.255.255.255
!
interface FastEthernet4/0/2
  ip vrf forwarding vpn2
  ip address 192.168.5.1 255.255.255.0
  mpls bgp forwarding
!
!
interface FastEthernet4/0/4
  ip vrf forwarding vpn1
  ip address 192.168.9.1 255.255.255.0
  mpls bgp forwarding

```

Example CSC-CE3

```

!
!
interface FastEthernet4/0/7
 ip address 192.168.38.1 255.255.255.0
 mpls label protocol ldp
 mpls ip
!
router ospf 200
 log-adjacency-changes
 auto-cost reference-bandwidth 1000
 nsf enforce global
 redistribute connected subnets
 network 192.168.17.17 0.0.0.0 area 200
 network 192.168.0.0 0.0.255.255 area 200
!
router bgp 200
 bgp router-id 192.168.17.17
 no bgp default ipv4-unicast
 bgp log-neighbor-changes
 bgp graceful-restart restart-time 120
 bgp graceful-restart stalepath-time 360
 bgp graceful-restart
 neighbor 192.168.16.16 remote-as 200
 neighbor 192.168.16.16 update-source Loopback0
!
 address-family vpnv4
  neighbor 192.168.16.16 activate
  neighbor 192.168.16.16 send-community extended
  bgp scan-time import 5
 exit-address-family
!
 address-family ipv4 vrf vpn2
  neighbor 192.168.55.0 remote-as 400
  neighbor 192.168.55.0 update-source FastEthernet4/0/2
  neighbor 192.168.55.0 activate
  neighbor 192.168.55.0 as-override
  neighbor 192.168.55.0 advertisement-interval 5
  neighbor 192.168.55.0 send-label
  no auto-summary
  no synchronization
 exit-address-family
!
 address-family ipv4 vrf vpn1
  neighbor 192.168.39.2 remote-as 300
  neighbor 192.168.39.2 update-source FastEthernet4/0/4
  neighbor 192.168.39.2 activate
  neighbor 192.168.39.2 as-override
  neighbor 192.168.39.2 advertisement-interval 5
  neighbor 192.168.39.2 send-label
  no auto-summary
  no synchronization
 exit-address-family
!

```

Example CSC-CE3

```

!
interface Loopback0
 ip address 192.168.18.18 255.255.255.255
!
!
interface Ethernet3/3
 ip address 192.168.40.2 255.255.255.0

```

```

mpls label protocol ldp
mpls ip
!
!
interface FastEthernet5/0
 ip address 192.168.39.2 255.255.255.0
 mpls bgp forwarding
!
!
router ospf 300
 log-adjacency-changes
 auto-cost reference-bandwidth 1000
 redistribute connected subnets
 redistribute bgp 300 metric 3 subnets
 network 192.168.18.18 0.0.0.0 area 300
 network 192.168.0.0 0.0.255.255 area 300
 distance ospf intra-area 19 inter-area 19
!
router bgp 300
 bgp log-neighbor-changes
 bgp graceful-restart restart-time 120
 bgp graceful-restart stalepath-time 360
 bgp graceful-restart
 neighbor 192.168.9.1 remote-as 200
!
 address-family ipv4
  redistribute connected
  redistribute ospf 300 metric 4 match internal external 1 external 2
  neighbor 192.168.9.1 activate
  neighbor 192.168.9.1 advertisement-interval 5
  neighbor 192.168.9.1 send-label
  no auto-summary
  no synchronization
 exit-address-family
!

```

Example CSC-CE 4

```

!
ip cef distributed
!
mpls ldp graceful-restart
mpls label protocol ldp
!
mpls ip
!
interface Loopback0
 ip address 192.168.24.24 255.255.255.255
!
!
interface FastEthernet1/1
 ip address 192.168.55.0 255.255.255.0
 mpls bgp forwarding
!
!
interface Ethernet3/5
 ip address 192.168.56.2 255.255.255.0
 mpls label protocol ldp
 mpls ip
!
!
router ospf 400
 log-adjacency-changes

```

Example PE 3

```

auto-cost reference-bandwidth 1000
redistribute connected subnets
redistribute bgp 400 metric 3 subnets
network 192.168.24.24 0.0.0.0 area 400
network 192.168.0.0 0.0.255.255 area 400
!
router bgp 400
  bgp log-neighbor-changes
  neighbor 192.168.5.1 remote-as 200
  !
  address-family ipv4
    redistribute connected
    redistribute ospf 400 metric 4 match internal external 1 external 2
    neighbor 192.168.5.1 activate
    neighbor 192.168.5.1 advertisement-interval 5
    neighbor 192.168.5.1 send-label
    no auto-summary
    no synchronization
  exit-address-family

```

Example PE 3

```

!
ip cef distributed
!
ip vrf vpn3
  rd 300:3
  route-target export 300:3
  route-target import 300:3
  mpls ip
!
!
mpls ldp graceful-restart
mpls label protocol ldp
!
!
interface Loopback0
  ip address 192.168.19.19 255.255.255.255
!
!
interface Ethernet5/1/1
  ip vrf forwarding vpn3
  ip address 192.168.43.1 255.255.255.0
!
!
interface Ethernet5/1/4
  ip address 192.168.40.1 255.255.255.0
  mpls label protocol ldp
  mpls ip
!
!
router ospf 300
  log-adjacency-changes
  auto-cost reference-bandwidth 1000
  nsf enforce global
  redistribute connected subnets
  network 192.168.19.19 0.0.0.0 area 300
  network 192.168.0.0 0.0.255.255 area 300
  network 192.168.0.0 0.0.255.255 area 300
!
router bgp 300
  bgp router-id 192.168.19.19
  bgp log-neighbor-changes

```



```

bgp graceful-restart restart-time 120
bgp graceful-restart stalepath-time 360
bgp graceful-restart
neighbor 192.168.192.10 remote-as 300
neighbor 192.168.192.10 update-source Loopback0
!
address-family ipv4
  no neighbor 192.168.192.10 activate
  no auto-summary
  no synchronization
exit-address-family
!
address-family vpnv4
  neighbor 192.168.192.10 activate
  neighbor 192.168.192.10 send-community extended
  bgp scan-time import 5
exit-address-family
!
address-family ipv4 vrf vpn3
  neighbor 192.168.43.2 remote-as 500
  neighbor 192.168.43.2 activate
  neighbor 192.168.43.2 as-override
  neighbor 192.168.43.2 advertisement-interval 5
  no auto-summary
  no synchronization
exit-address-family

```

Example PE 4

```

!
ip cef distributed
!
ip vrf vpn4
  rd 400:4
  route-target export 400:4
  route-target import 400:4
!
mpls ldp graceful-restart
mpls ldp protocol ldp
!
mpls ip
!
interface Loopback0
  ip address 192.168.25.25 255.255.255.255
!
!
interface Ethernet5/0/4
  ip address 192.168.56.1 255.255.255.0
  mpls label protocol ldp
  mpls ip
!
!
interface Ethernet5/0/7
  ip vrf forwarding vpn4
  ip address 192.168.44.1 255.255.255.0
!
!
router ospf 400
  log-adjacency-changes
  auto-cost reference-bandwidth 1000
  nsf enforce global
  redistribute connected subnets
  network 192.168.25.25 0.0.0.0 area 400

```

```

network 192.168.0.0 0.0.255.255 area 400
!
router bgp 400
  bgp router-id 192.168.25.25
  bgp log-neighbor-changes
  bgp graceful-restart restart-time 120
  bgp graceful-restart stalepath-time 360
  bgp graceful-restart
  neighbor 192.168.13.13 remote-as 400
  neighbor 192.168.13.13 ebgp-multihop 7
  neighbor 192.168.13.13 update-source Loopback0
  !
  address-family ipv4
    no neighbor 192.168.13.13 activate
    no auto-summary
    no synchronization
  exit-address-family
  !
  address-family vpv4
    neighbor 192.168.13.13 activate
    neighbor 192.168.13.13 send-community extended
    bgp scan-time import 5
  exit-address-family
  !
  address-family ipv4 vrf vpn4
    neighbor 192.168.44.2 remote-as 600
    neighbor 192.168.44.2 activate
    neighbor 192.168.44.2 as-override
    neighbor 192.168.44.2 advertisement-interval 5
    no auto-summary
    no synchronization
  exit-address-family
  !

```

Additional References

Related Documents

Related Topic	Document Title
Cisco IOS commands	Cisco IOS Master Commands List, All Releases
MPLS commands	<i>Cisco IOS Multiprotocol Label Switching Command Reference</i>
MPLS VPNs	Configuring MPLS Layer 3 VPNs
MPLS VPN interautonomous systems	<ul style="list-style-type: none"> • MPLS VPN Inter-AS with ASBRs Exchanging VPN-IPv4 Addresses • MPLS VPN Inter-AS with ASBRs Exchanging IPv4 Routes and MPLS Labels

Standards

Standard	Title
No new or modified standards are supported by this feature, and support for existing standards has not been modified by this feature.	--

MIBs

MIB	MIBs Link
No new or modified MIBs are supported by this feature, and support for existing MIBs has not been modified by this feature.	To locate and download MIBs for selected platforms, Cisco software releases, and feature sets, use Cisco MIB Locator found at the following URL: http://www.cisco.com/go/mibs

RFCs

RFC	Title
RFC 2283	<i>Multiprotocol Extensions for BGP-4</i>
RFC 4364	<i>BGP/MPLS IP Virtual Private Networks</i>

Technical Assistance

Description	Link
<p>The Cisco Support website provides extensive online resources, including documentation and tools for troubleshooting and resolving technical issues with Cisco products and technologies.</p> <p>To receive security and technical information about your products, you can subscribe to various services, such as the Product Alert Tool (accessed from Field Notices), the Cisco Technical Services Newsletter, and Really Simple Syndication (RSS) Feeds.</p> <p>Access to most tools on the Cisco Support website requires a Cisco.com user ID and password.</p>	http://www.cisco.com/cisco/web/support/index.html

Feature Information for MPLS VPN--Inter-AS Option AB

The following table provides release information about the feature or features described in this module. This table lists only the software release that introduced support for a given feature in a given software release train. Unless noted otherwise, subsequent releases of that software release train also support that feature.

Use Cisco Feature Navigator to find information about platform support and Cisco software image support. To access Cisco Feature Navigator, go to www.cisco.com/go/cfn. An account on Cisco.com is not required.

Table 1: Feature Information for MPLS VPN--Inter-AS Option AB

Feature Name	Release	Feature Information
MPLS VPN--Inter-AS Option AB	12.2(33)SRC 15.0(1)M 15.0(1)S 15.0(1)SY Cisco IOS XE Release 2.4	This feature combines the best functionality of an Inter-AS Option 10 A and Inter-AS Option 10 B network to allow an MPLS VPN service provider to interconnect different autonomous systems to provide VPN services. In Cisco IOS Release 12.2(33)SRC, this feature was introduced. In Cisco IOS Release 15.0(1)M, this feature was implemented on Cisco 1900, 2900, 3800, and 3900 series routers. In Cisco IOS XE Release 2.4, this feature was implemented on the Cisco ASR 1000 Series Routers. These commands were introduced or modified: neighbor inter-as-hybrid, inter-as-hybrid.
MPLS VPN--Inter-AS Option AB+	15.0(1)SY	The MPLS VPN—Inter-AS Option AB+ feature addresses the scalability concerns of MPLS VPN—Inter-AS Option A by using a single BGP session to signal VPN prefixes (as described in Inter-AS Option B). In an Inter-AS AB+ deployment, the forwarding connections between the ASBRs are maintained on a per-VRF basis while the control plane information is exchanged by a single Multiprotocol BGP session. In Cisco IOS Release 15.0(1)SY, this feature was introduced. These commands were introduced or modified: inter-as-hybrid.

Glossary

ASBR -- Autonomous System Boundary router. A router that connects one autonomous system to another.

autonomous system --A collection of networks under a common administration sharing a common routing strategy.

BGP --Border Gateway Protocol. An interdomain routing protocol that exchanges network reachability information with other BGP systems (which may be within the same autonomous system or between multiple autonomous systems).

CE router--customer edge router. A router that is part of a customer network and that interfaces to a provider edge (PE) router. CE routers do not recognize associated MPLS VPNs.

CSC --Carrier Supporting Carrier. A hierarchical VPN model that allows small service providers, or customer carriers, to interconnect their IP or MPLS networks over an MPLS backbone. This eliminates the need for customer carriers to build and maintain their own MPLS backbone.

eBGP --external Border Gateway Protocol. A BGP between routers located within different autonomous systems. When two routers, located in different autonomous systems, are more than one hop away from one another, the eBGP session between the two routers is considered a multihop BGP.

edge router--A router that is at the edge of the network. It defines the boundary of the MPLS network. It receives and transmits packets. Also referred to as edge label switch router and label edge router.

iBGP --internal Border Gateway Protocol. A BGP between routers within the same autonomous system.

IGP --Interior Gateway Protocol. Internet protocol used to exchange routing information within a single autonomous system. Examples of common Internet IGP protocols include IGRP, OSPF, IS-IS, and RIP.

IP --Internet Protocol. Network layer protocol in the TCP/IP stack offering a connectionless internetwork service. IP provides features for addressing, type-of-service specification, fragmentation and reassembly, and security. Defined in RFC 791.

LDP --Label Distribution Protocol. A standard protocol between MPLS-enabled routers to negotiate the labels (addresses) used to forward packets.

LFIB --Label Forwarding Information Base. Data structure used in MPLS to hold information about incoming and outgoing labels and associated Forwarding Equivalence Class (FEC) packets.

MP-BGP --Multiprotocol BGP.

MPLS --Multiprotocol Label Switching. The name of the IETF working group responsible for label switching, and the name of the label switching approach it has standardized.

NLRI --Network Layer Reachability Information. The BGP sends routing update messages containing NLRI to describe a route and how to get there. In this context, an NLRI is a prefix. A BGP update message carries one or more NLRI prefixes and the attributes of a route for the NLRI prefixes; the route attributes include a BGP next hop gateway address and extended community values.

NSF --Nonstop forwarding enables routers to continuously forward IP packets following a Route Processor takeover or switchover to another Route Processor. NSF maintains and updates Layer 3 routing and forwarding information in the backup Route Processor to ensure that IP packets and routing protocol information are forwarded continuously during the switchover and route convergence process.

PE router--provider edge router. A router that is part of a service provider's network. It is connected to a customer edge (CE) router. All MPLS VPN processing occurs in the PE router.

QoS --quality of service. Measure of performance for a transmission system that indicates its transmission quality and service availability.

RD --route distinguisher. An 8-byte value that is concatenated with an IPv4 prefix to create a unique VPN-IPv4 prefix.

RT --route target. Extended community attribute used to identify the VRF routing table into which a prefix is imported.

SLA --Service Level Agreement given to VPN subscribers.

VPN --Virtual Private Network. A secure MPLS-based network that shares resources on one or more physical networks (typically implemented by one or more service providers). A VPN contains geographically dispersed sites that can communicate securely over a shared backbone network.

VRF --VPN routing and forwarding instance. Routing information that defines a VPN site that is attached to a PE router. A VRF consists of an IP routing table, a derived forwarding table, a set of interfaces that use the forwarding table, and a set of rules and routing protocols that determine what goes into the forwarding table.

