



MPLS VPN--MIB Support

This document describes the Simple Network Management Protocol (SNMP) agent support in Cisco software for Multiprotocol Label Switching (MPLS) Virtual Private Network (VPN) management, as implemented in the draft *MPLS/BGP Virtual Private Network Management Information Base Using SMIPv2* (*draft-ietf-ppvpn-mpls-vpn-mib-05.txt*). This document also describes the `cMplsNumVrfRouteMaxThreshCleared` notification, which is implemented as part of the proprietary MIB `CISCO-IETF-PPVNP-MPLS-VPN-MIB`.

- [Finding Feature Information, on page 1](#)
- [Prerequisites for MPLS VPN--MIB Support, on page 1](#)
- [Restrictions for MPLS VPN--MIB Support, on page 2](#)
- [Information About MPLS VPN--MIB Support, on page 2](#)
- [How to Configure MPLS VPN--MIB Support, on page 19](#)
- [Configuration Examples for MPLS VPN--MIB Support, on page 24](#)
- [Additional References, on page 25](#)
- [Feature Information for MPLS VPN--MIB Support, on page 26](#)
- [Glossary, on page 27](#)

Finding Feature Information

Your software release may not support all the features documented in this module. For the latest caveats and feature information, see [Bug Search Tool](#) and the release notes for your platform and software release. To find information about the features documented in this module, and to see a list of the releases in which each feature is supported, see the feature information table at the end of this module.

Use Cisco Feature Navigator to find information about platform support and Cisco software image support. To access Cisco Feature Navigator, go to www.cisco.com/go/cfn. An account on Cisco.com is not required.

Prerequisites for MPLS VPN--MIB Support

- SNMP is installed and enabled on the label switching routers.
- MPLS is enabled on the label switching routers.
- Multiprotocol Border Gateway Protocol (BGP) is enabled on the label switching routers.
- Cisco Express Forwarding is enabled on the label switching routers.

Restrictions for MPLS VPN--MIB Support

- Configuration of the MIB using the `snmp set` command is not supported, except for trap-related objects, such as `mplsVpnNotificationEnable` and `mplsVpnVrfSecIllegalLabelRcvThresh`.
- The `mplsVpnVrfBgpNbrPrefixTable` is not supported.

Information About MPLS VPN--MIB Support

MPLS VPN Overview

The MPLS VPN technology allows service providers to offer intranet and extranet VPN services that directly connect their customers' remote offices to a public network with the same security and service levels that a private network offers. Each VPN is associated with one or more VPN routing and forwarding (VRF) instances. A VRF is created for each VPN defined on a router and contains most of the information needed to manage and monitor MPLS VPNs: an IP routing table, a derived Cisco Express Forwarding table, a set of interfaces that use this forwarding table, and a set of rules and routing protocol parameters that control the information that is included in the routing table.

MPLS VPN MIB Overview

The Provider-Provisioned VPN (PPVPN)-MPLS-VPN MIB provides access to MPLS VRF information, and interfaces included in the VRF, and other configuration and monitoring information.

The PPVPN-MPLS-VPN MIB provides the following benefits:

- A standards-based SNMP interface for retrieving information about critical MPLS VPN events.
- VRF information to assist in the management and monitoring of MPLS VPNs.
- Information, in conjunction with the Interfaces MIB, about interfaces assigned to VRFs.
- Performance statistics for all VRFs on a router.
- The generation and queuing of notifications that call attention to major changes in the operational status of MPLS VPN enabled interfaces; the forwarding of notification messages to a designated network management system (NMS) for evaluation and action by network administrators.
- Advanced warning when VPN routing tables are approaching or exceed their capacity.
- Warnings about the reception of illegal labels on a VRF-enabled interface. Such receptions may indicate misconfiguration or an attempt to violate security.

This document also describes the CISCO-IETF-PPVPN-MPLS-VPN-MIB, which contains the `cMplsNumVrfRouteMaxThreshCleared` notification.

MPLS VPN MIB and the IETF

SNMP agent code operating with the PPVPN-MPLS-VPN MIB enables a standardized, SNMP-based approach to managing MPLS VPNs in Cisco software.

The PPVPN-MPLS-VPN MIB is based on the Internet Engineering Task Force draft MIB specification *draft-ietf-ppvpn-mpls-vpn-mib-05.txt*, which includes objects describing features that support MPLS VPN events. This IETF draft MIB, which undergoes revisions from time to time, is becoming a standard. Accordingly, the Cisco implementation of the PPVPN-MPLS-VPN MIB is expected to track the evolution of the IETF draft MIB, and may change accordingly.

Some slight differences between the IETF draft MIB and the actual implementation of MPLS VPNs within Cisco software require some minor translations between the PPVPN-MPLS-VPN MIB and the internal data structures of Cisco software. These translations are accomplished by means of the SNMP agent code. Also, while running as a low priority process, the SNMP agent provides a management interface to Cisco software. SNMP adds little overhead on the normal functions of the device.

The SNMP objects defined in the PPVPN-MPLS-VPN MIB can be viewed by any standard SNMP utility. The network administrator can retrieve information in the PPVPN-MPLS-VPN MIB using standard SNMP get and getnext operations for SNMP v1, v2, and v3.

All PPVPN-MPLS-VPN MIB objects are based on the IETF draft MIB; thus, no Cisco-specific SNMP application is required to support the functions and operations pertaining to the PPVPN-MPLS-VPN MIB features.

Capabilities Supported by PPVPN-MPLS-VPN MIB

The PPVPN-MPLS-VPN MIB provides you with the ability to do the following:

- Gather routing and forwarding information for MPLS VPNs on a router.
- Expose information in the VRF routing table.
- Gather information on BGP configuration related to VPNs and VRF interfaces and statistics.
- Emit notification messages that signal changes when critical MPLS VPN events occur.
- Enable, disable, and configure notification messages for MPLS VPN events by using extensions to existing SNMP command-line interface (CLI) commands.
- Specify the IP address of NMS in the operating environment to which notification messages are sent.
- Write notification configurations into nonvolatile memory.

Functional Structure of the PPVPN-MPLS-VPN MIB

The SNMP agent code supporting the PPVPN-MPLS-VPN MIB follows the existing model for such code in Cisco software and is, in part, generated by the Cisco software tool set, based on the MIB source code.

The SNMP agent code, which has a layered structure that is common to MIB support code in Cisco software, consists of four layers:

- Platform-independent layer--This layer is generated primarily by the MIB development Cisco software tool set and incorporates platform- and implementation-independent functions. The Cisco MIB development tool set creates a standard set of files associated with a MIB.

- Application interface layer--The functions, names, and template code for MIB objects in this layer are also generated by the MIB development Cisco software tool set.
- Application-specific layer--This layer provides an interface between the application interface layer and the API and data structures layer below and performs tasks needed to retrieve required information from Cisco software, such as searching through data structures.
- API and data structures layer--This layer contains the data structures or APIs within Cisco software that are retrieved or called in order to set or retrieve SNMP management information.

Supported Objects in PPVPN-MPLS-VPN MIB

The PPVPN-MPLS-VPN MIB contains numerous tables and object definitions that provide read-only SNMP management support for the MPLS VPN feature in Cisco IOS software. The PPVPN-MPLS-VPN MIB conforms to Abstract Syntax Notation One (ASN.1), thus reflecting an idealized MPLS VPN database.

Using any standard SNMP network management application, you can retrieve and display information from the PPVPN-MPLS-VPN MIB using GET operations; similarly, you can traverse information in the MIB database for display using GETNEXT operations.

The PPVPN-MPLS-VPN MIB tables and objects are described briefly in the following sections:

The figure below shows a simple MPLS VPN configuration. This configuration includes two customer MPLS VPNs, labeled VPN1 and VPN2, and a simple provider network that consists of two provider edge (PE) routers, labeled PE1 and PE2, and a provider core router labeled P. The figure below shows the following sample configuration:

- VRF names--VPN1 and VPN2
- Interfaces associated with VRFs--Et1, Et2, and At3/0
- Routing protocols--Open Shortest Path First. Link-state (OSPF), Routing Information Protocol (RIP), and internal Border Gateway Protocol (IBGP)
- Routes associated with VPN1--10.1.0.0, 10.2.0.0, and 10.3.0.0
- Routes associated with VPN2--172.16.1.0 and 172.16.2.0
- Routes associated with the provider network--192.168.1.0, 192.168.2.0, and 192.168.3.0

This configuration is used in this document to explain MPLS VPN events that are monitored and managed by the PPVPN-MPLS-VPN MIB.

Figure 1: Sample MPLS VPN Configuration

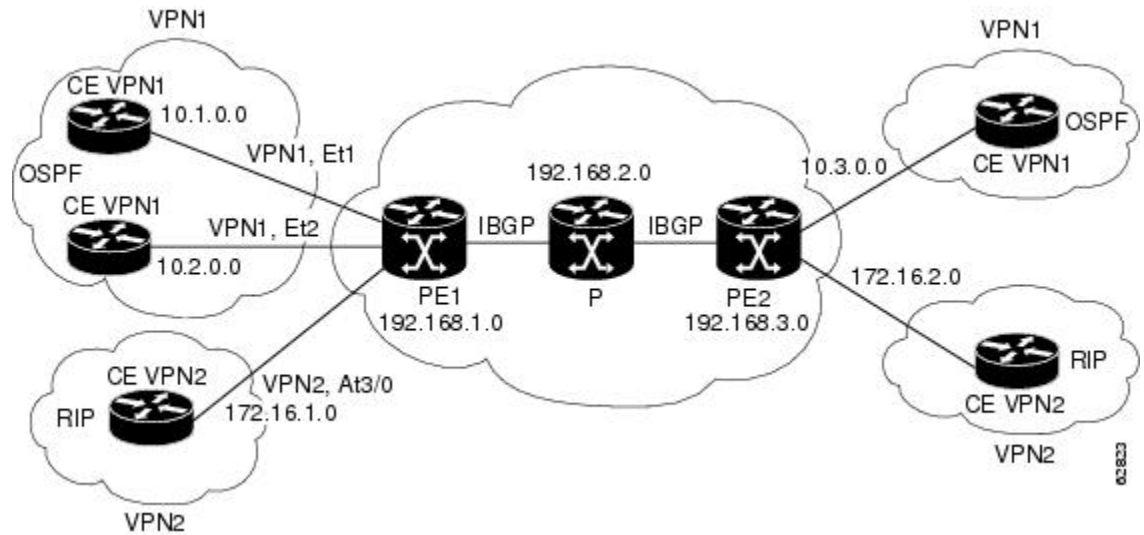

Scalar Objects

The table below shows the supported PPVPN-MPLS-VPN MIB scalar objects.

Table 1: PPVPN-MPLS-VPN MIB Scalar Objects

MIB Object	Function
mplsVpnConfiguredVrfs	The number of VRFs configured on the router, including VRFs recently deleted.
mplsVpnActiveVrfs	The number of VRFs that are active on the router. An active VRF is assigned to at least one interface that is in the operationally up state.
mplsVpnConnectedInterfaces	The total number of interfaces assigned to any VRF.
mplsVpnNotificationEnable	<p>A value that indicates whether all the PPVPN-MPLS-VPN MIB notifications are enabled:</p> <ul style="list-style-type: none"> Setting this object to true enables all notifications defined in the PPVPN-MPLS-VPN MIB. Setting this object to false disables all notifications defined in the MIB. <p>This is one of the few objects that is writable.</p>
mplsVpnVrfConfMaxPossibleRoutes	A number that indicates the amount of routes that this router is capable of storing. This value cannot be determined because it is based on the amount of available memory in the system. Therefore, this object is set to zero (0).

MIB Tables

The PPVPN-MPLS-VPN MIB implementation supports the following tables described in this section:

mplsVpnVrfTable

Each VRF is referenced by its VRF name (mplsVpnVrfName). The table below lists the MIB objects and their functions for this table.

Table 2: PPVPN-MPLS-VPN MIB Objects for the mplsVpnVrfTable

MIB Object	Function
mplsVpnVrfName	The name associated with this VRF. When this object is used as an index to a table, the first octet is the string length, and subsequent octets are the ASCII codes of each character. For example, "vpn1" is represented as 4.118.112.110.49.
mplsVpnVrfDescription	The description of the VRF. This is specified with the following configuration command: <pre>Router(config)# ip vrf vrf-name Router(config-vrf)# description vrf-description</pre>
mplsVpnVrfRouteDistinguisher	The route distinguisher for this VRF. This is specified with the following configuration command: <pre>Router(config)# ip vrf vrf-name Router(config-vrf)# rd route-distinguisher</pre>
mplsVpnVrfCreationTime	The value of the sysUpTime when this VRF entry was created.
mplsVpnVrfOperStatus	The operational status of this VRF. A VRF is up (1) when at least one interface associated with the VRF is up. A VRF is down (2) when: <ul style="list-style-type: none"> • No interfaces exist whose ifOperStatus = up (1). • No interfaces are associated with this VRF.
mplsVpnVrfActiveInterfaces	The number of interfaces assigned to this VRF that are operationally up.
mplsVpnVrfAssociatedInterfaces	The number of interfaces assigned to this VRF, independent of the operational status.

MIB Object	Function
mplsVpnVrfConfMidRouteThreshold	<p>The middle route threshold. If the amount of routes in the VRF crosses this threshold, an mplsNumVrfRouteMidThreshExceeded notification is sent (if notifications are enabled and configured). You can set this value in configuration mode as a percentage of the maximum with the maximum routes limit {<i>warn-threshold</i> warn-only} command, as follows:</p> <pre>Router(config)# ip vrf vpn1 Router(config-vrf)# maximum routes 1000 50</pre> <p>The middle or warn threshold is set for VRF vpn1 as 50 percent of the maximum route threshold.</p> <p>The following command sets a middle threshold of 1000 routes. An mplsNumVrfRouteMidThreshExceeded notification is sent when this threshold is exceeded. However, additional routes are still allowed because a maximum route threshold is not set with this command.</p> <pre>Router(config-vrf)# maximum routes 1000 warn-only</pre>
mplsVpnVrfConfHighRouteThreshold	<p>The maximum route threshold. If the number of routes in the VRF crosses this threshold, an mplsNumVrfRouteMaxThreshExceeded notification is sent (if notifications are enabled and configured). You can set this value in configuration mode with the maximum routes limit {<i>warn-threshold</i> warn-only} command as follows:</p> <pre>Router(config)# ip vrf vpn2 Router(config-vrf)# maximum routes 1000 75</pre> <p>The maximum route threshold is set for 1000 routes for VRF vpn2 with a middle or warn threshold of 75 percent of this threshold.</p>
mplsVpnVrfConfMaxRoutes	This value is the same as the mplsVpnVrfConfHighRouteThreshold.
mplsVpnVrfConfLastChanged	<p>The value of sysUpTime when the configuration of the VRF changes or interfaces are assigned or unassigned from the VRF.</p> <p>Note This object is updated only when values in this table change.</p>
mplsVpnVrfConfRowStatus	Read-only implementation. This object normally reads “active (1),” but may read “notInService (2),” if a VRF was recently deleted.
mplsVpnVrfConfStorageType	Read-only implementation. This object always reads “volatile (2).”

mplsVpnInterfaceConfTable

In Cisco software, a VRF is associated with one MPLS VPN. Zero or more interfaces can be associated with a VRF. A VRF uses an interface that is defined in the ifTable of the Interfaces Group of MIB II (IFMIB). The IFMIB defines objects for managing interfaces. The ifTable of this MIB contains information on each interface in the network. The mplsVpnInterfaceConfTable associates a VRF from the mplsVpnVrfTable with a forwarding interface from the ifTable. The figure below shows the relationship between VRFs and interfaces defined in the ifTable and the mplsVpnInterfaceConfTable.

Figure 2: VRFs, the Interfaces MIB, and the mplsVpnInterfaceConfTable

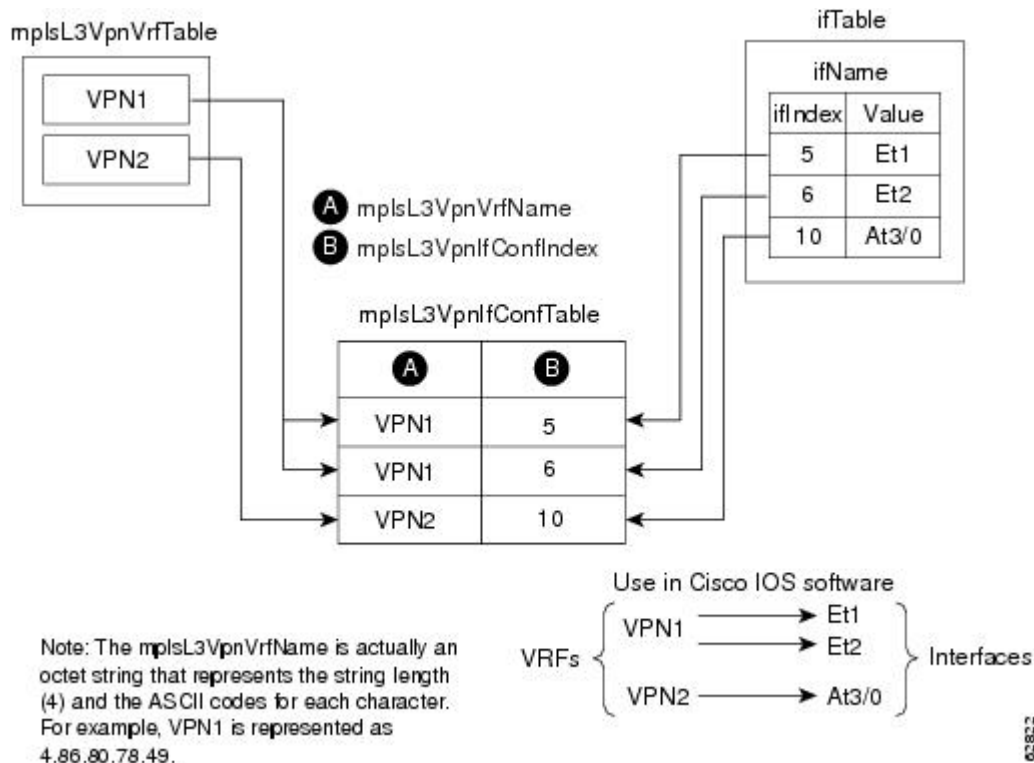

Entries in the VPN interface configuration table (`mplsVpnInterfaceConfTable`) represent the interfaces that are assigned to each VRF. The information available in this table is also displayed with the **show ip vrf** command.

The `mplsVpnInterfaceConfTable` shows how interfaces are assigned to VRFs. A label switch router (LSR) creates an entry in this table for every interface capable of supporting MPLS VPNs.

The `mplsVpnInterfaceConfTable` is indexed by the following:

- `mplsVpnVrfName`--The VRF name
- `mplsVpnInterfaceConfIndex`--An identifier that is the same as the `ifIndex` from the Interface MIB of the interface assigned to the VRF

The table below lists the MIB objects and their functions for this table.

Table 3: PPVPN-MPLS-VPN MIB Objects for the `mplsVpnInterfaceConfTable`

MIB Object	Function
<code>mplsVpnInterfaceConfIndex</code>	Provides the interface MIB <code>ifIndex</code> of this interface that is assigned to a VRF.
<code>mplsVpnInterfaceLabelEdgeType</code>	Indicates whether the interface is a provider edge interface (1) or a customer edge interface (2). This value is always <code>providerEdge</code> (1) because in Cisco IOS, <code>customerEdge</code> interfaces are not assigned to VRFs and do not appear in this table.

MIB Object	Function
mplsVpnInterfaceVpnClassification	Specifies what type of VPN this interface is providing: carrier supporting carrier (CsC) (1), enterprise (2), or InterProvider (3). This value is set to enterprise (2) if MPLS is not enabled and to carrier supporting carrier (1) if MPLS is enabled on this interface.
mplsVpnInterfaceVpnRouteDistProtocol	Indicates the route distribution protocols that are being used to redistribute routes with BGP on this interface: BGP (2), OSPF (3), or RIP (4). In Cisco software, router processes are defined and redistributed on a per-VRF basis, not per-interface. Therefore, all interfaces assigned to the same VRF have the same value for this object.
mplsVpnInterfaceConfStorageType	Read-only implementation. This object always reads "volatile (2)."
mplsVpnInterfaceConfRowStatus	Read-only implementation. This object normally reads "active (1)," but may read "notInService (2)," if a VRF was recently deleted.

mplsVpnVrfRouteTargetTable

The route target table (mplsVpnVrfRouteTargetTable) describes the route target communities that are defined for a particular VRF. An LSR creates an entry in this table for each target configured for a VRF supporting an MPLS VPN instance.

The distribution of VPN routing information is controlled through the use of VPN route target communities, implemented by BGP extended communities. Distribution of VPN routing information works as follows:

- When a VPN route learned from a customer edge (CE) router is injected into BGP, a list of VPN route target extended community attributes is associated with it. Typically the list of route target community values is set from an export list of route targets associated with the VRF from which the route was learned.
- An import list of route target extended communities is associated with each VRF. The import list defines route target extended community attributes a route must have for the route to be imported into the VRF. For example, if the import list for a particular VRF includes route target communities A, B, and C, then any VPN route that carries any of those route target extended communities--A, B, or C--is imported into the VRF.

The figure below shows a sample configuration and its relationship to an mplsVpnVrfRouteTargetTable. A route target table exists on each PE router. Routers with route distinguishers (RDs) 100:1, 100:2, and 100:3 are shown in the sample configuration. Routers with RDs 100:4 and 100:5 are not shown in the figure, but are included in the route targets for PE2 and in the mplsVpnVrfRouteTargetTable.

Figure 3: Sample Configuration and the mplsVpnVrfRouteTargetTable

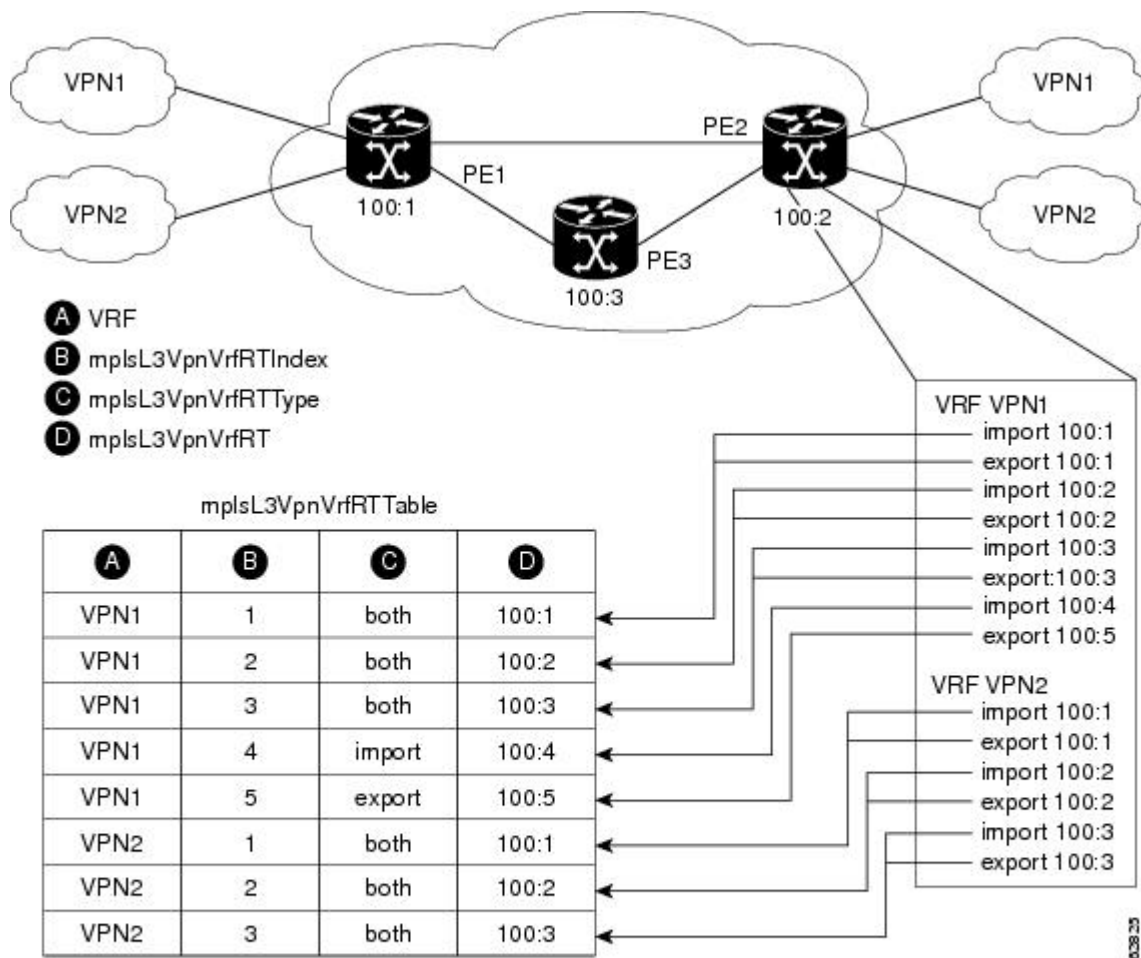

Note: The mplsL3VpnVrfName is actually an octet string that represents the string length (4) and the ASCII codes for each character. For example, VPN1 is represented as 4.86.80.78.49.

The mplsVpnVrfRouteTargetTable shows the import and export route targets for each VRF. The table is indexed by the following:

- mplsVpnVrfName--The VRF name
- mplsVpnVrfRouteTargetIndex--The route target entry identifier
- mplsVpnVrfRouteTargetType--A value specifying whether the entry is an import route target, export route target, or is defined as both

The table below lists the MIB objects and their functions for this table.

Table 4: PPVPN-MPLS-VPN MIB Objects for the mplsVpnVrfRouteTargetTable

MIB Object	Function
mplsVpnVrfRouteTargetIndex	A value that defines each route target's position in the table.
mplsVpnVrfRouteTargetType	Determines which type of route target the entry represents: import (1), export (2), or both (3).
mplsVpnVrfRouteTarget	Determines the route distinguisher for this target.
mplsVpnVrfRouteTargetDescr	Description of the route target. This object is not supported. Therefore, the object is the same as mplsVpnVrfRouteTarget.
mplsVpnVrfRouteTargetRowStatus	Read-only implementation. This object normally reads "active (1)," but may read "notInService (2)," if a VRF was recently deleted.

mplsVpnVrfBgpNbrAddrTable

The BGP neighbor address table (mplsVpnVrfBgpNbrAddrTable) represents the MPLS external Border Gateway Protocol (eBGP) neighbors that are defined for a particular VRF. An LSR creates an entry for every BGP neighbor that is defined in the VRF's address-family.

The mplsVpnVrfBgpNbrAddrTable is indexed by the following:

- mplsVpnVrfName--The VRF name
- mplsVpnInterfaceConfIndex--An identifier that is the same as the ifIndex from the Interface MIB of the interface assigned to the VRF
- mplsVpnVrfBgpNbrIndex--The IP address of the neighbor

The table below lists the MIB objects and their functions for this table.

Table 5: PPVPN-MPLS-VPN MIB Objects for the mplsVpnVrfBgpNbrAddrTable

MIB Object	Function
mplsVpnVrfBgpNbrIndex	The IPv4 address of the eBGP neighbor.
mplsVpnVrfBgpNbrRole	The role of this eBGP neighbor: customer edge (1) or provider edge (2). If the object mplsVpnInterfaceVpnClassification is CSC, then this value is provider edge (2); otherwise, this value is customer edge (1).
mplsVpnVrfBgpNbrType	Address type of this eBGP neighbor. The MIB supports only IPv4 (1). Therefore, this object returns "ipv4 (1)."
mplsVpnVrfBgpNbrAddr	IP address of the eBGP neighbor.
mplsVpnVrfBgpNbrRowStatus	Read-only implementation. This object normally reads "active (1)," but may read "notInService (2)" if a VRF was recently deleted.
mplsVpnVrfBgpNbrStorageType	Read-only implementation. This object always reads "volatile (2)."

mplsVpnVrfSecTable

The VRF security table (mplsVpnVrfSecTable) provides information about security for each VRF. An LSR creates an entry in this table for every VRF capable of supporting MPLS VPN.

The mplsVpnVrfSecTable *augments* the mplsVpnVrfTable and has the same indexing.

The table below lists the MIB objects and their functions for this table.

Table 6: PPVPN-MPLS-VPN MIB Objects for the mplsVpnVrfSecTable

MIB Object	Function
mplsVpnVrfSecIllegalLabelViolations	<p>The number of illegally received labels on a VRF interface. Only illegal labels are counted by this object, therefore the object only applies to a VRF interface that is MPLS enabled (CSC situation).</p> <p>This counter is incremented whenever a label is received that is above or below the valid label range, not in the global label forwarding table, or is received on the wrong VRF (that is, table IDs for the receiving interface and appropriate VRF label forwarding table do not match).</p>
mplsVpnVrfSecIllegalLabelRcvThresh	<p>Notification threshold for illegal labels received on this VRF. When the number of illegal labels received on this interface crosses this threshold, an mplsNumVrfSecIllegalLabelThreshExceeded notification is sent (if the notification is enabled and configured).</p> <p>This object is one of the few in this MIB agent that supports the SNMP SET operation, which allows you to change this value.</p>

mplsVpnVrfPerfTable

The VRF performance table (mplsVpnVrfPerfTable) provides statistical performance information for each VRF. An LSR creates an entry in this table for every VRF capable of supporting MPLS VPN.

The mplsVpnVrfPerfTable *augments* the mplsVpnVrfTable and has the same indexing.

The table below lists the MIB objects and their functions for this table.

Table 7: PPVPN-MPLS-VPN MIB Objects for the mplsVpnVrfPerfTable

MIB Objects	Functions
mplsVpnVrfPerfRoutesAdded	The number of routes added to this VRF over the course of its lifetime.
mplsVpnVrfPerfRoutesDeleted	The number of routes removed from this VRF.
mplsVpnVrfPerfCurrNumRoutes	The number of routes currently defined within this VRF.

mplsVpnVrfRouteTable

The VRF routing table (mplsVpnVrfRouteTable) provides the IP routing table information for each VRF. The information available in this table can also be accessed with the **show ip route vrf vrf-name** command. For example, for PE1 in the figure above:

- With the **show ip route vrf vpn1** command, you would see results like the following:

```

Router# show ip route vrf vpn1
Codes: C - connected, S - static, I - IGRP, R - RIP, M - mobile, B - BGP
D - EIGRP, EX - EIGRP external, O - OSPF, IA - OSPF inter area
N1 - OSPF NSSA external type 1, N2 - OSPF NSSA external type 2
E1 - OSPF external type 1, E2 - OSPF external type 2, E - EGP
i - IS-IS, L1 - IS-IS level-1, L2 - IS-IS level-2, ia - IS-IS inter area
* - candidate default, U - per-user static route, o - ODR
P - periodic downloaded static route
!
Gateway of last resort is not set
!
    10.0.0.0/32 is subnetted, 3 subnets
B       10.3.0.0 [200/0] via 192.168.2.1, 04:36:33
C       10.1.0.0/16 is directly connected, FastEthernet1
C       10.2.0.0/16 [200/0] directly connected FastEthernet2, 04:36:33

```

- With the **show ip route vrf vpn2** command, you would see results like the following:

```

Router# show ip route vrf vpn2
Codes: C - connected, S - static, I - IGRP, R - RIP, M - mobile, B - BGP
D - EIGRP, EX - EIGRP external, O - OSPF, IA - OSPF inter area
N1 - OSPF NSSA external type 1, N2 - OSPF NSSA external type 2
E1 - OSPF external type 1, E2 - OSPF external type 2, E - EGP
i - IS-IS, L1 - IS-IS level-1, L2 - IS-IS level-2, ia - IS-IS inter area
* - candidate default, U - per-user static route, o - ODR
P - periodic downloaded static route
!
Gateway of last resort is not set
!
    172.16.0.0/32 is subnetted, 2 subnets
B       172.16.2.0 [200/0] via 192.168.2.1, 04:36:33
C       172.16.1.0 is directly connected, ATM 3/0

```

The figure below shows the relationship of the routing tables, the VRFs, and the mplsVpnVrfRouteTable. You can display information about the VPN1 and VPN2 route tables using the **show ip route vrf vrf-name** command. The global route table is the same as ipCidrRouteTable in the IP-FORWARD-MIB. You can display information about the global route table with the **show ip route** command.

Figure 4: Route Table, VRFs, and the mplsVpnVrfRouteTable

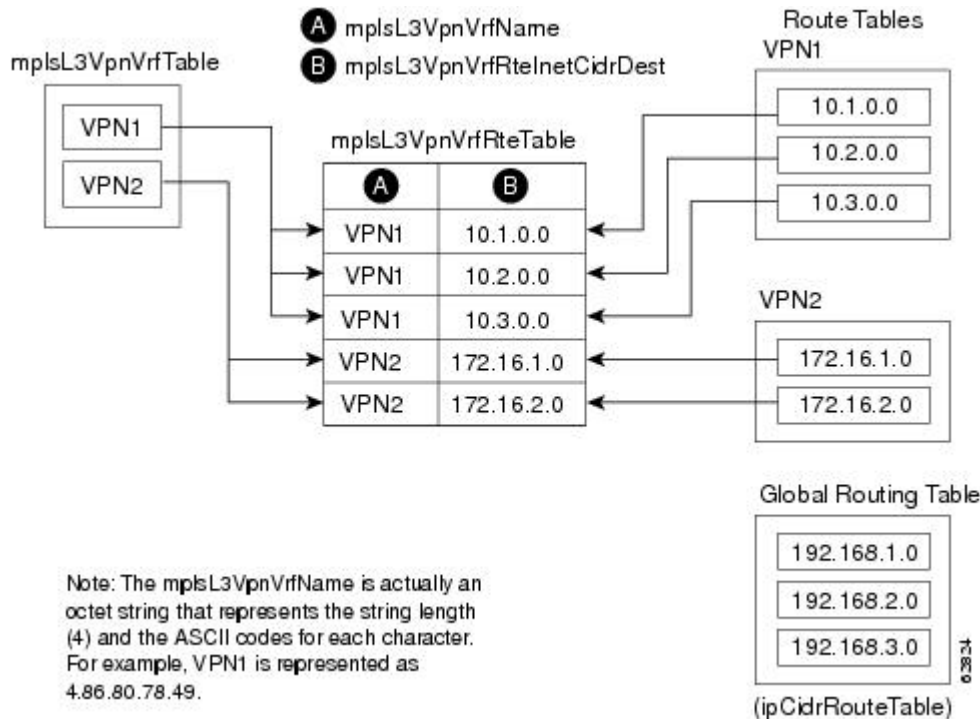

An LSR creates an entry in this table for every route that is configured, either dynamically or statically, within the context of a specific VRF capable of supporting MPLS VPN.

The mplsVpnVrfRouteTable is indexed by the following:

- mplsVpnVrfName--The VRF name, which provides the VRF routing context
- mplsVpnVrfRouteDest--The IP destination address
- mplsVpnVrfRouteMask--The IP destination mask
- mplsVpnVrfRouteTos--The IP header ToS bits
- mplsVpnVrfRouteNextHop--The IP address of the next hop for each route entry



Note The ToS bits are not supported and, therefore, are always 0.

The table below lists the MIB objects and their functions for the mplsVpnVrfRouteTable. This table represents VRF-specific routes. The global routing table is the ipCidrRouteTable in the IP-FORWARD-MIB.

Table 8: PPVPN-MPLS-VPN MIB Objects for the mplsVpnVrfRouteTable

MIB Object	Function
mplsVpnVrfRouteDest	The destination IP address defined for this route.

MIB Object	Function
mplsVpnVrfRouteDestAddrType	The address type of the IP destination address (mplsVpnVrfRouteDest). This MIB implementation supports only IPv4 (1). Therefore, this object has a value of "ipv4 (1)."
mplsVpnVrfRouteMask	The destination IP address mask defined for this route.
mplsVpnVrfRouteMaskAddrType	The address type of the destination IP address mask. This MIB implementation supports only IPv4 (1). Therefore, this object has a value of "ipv4 (1)."
mplsVpnVrfRouteTos	The ToS bits from the IP header for this route. Cisco software supports only ToS bits of zero. Therefore, the object is always 0.
mplsVpnVrfRouteNextHop	The next hop IP address defined for this route.
mplsVpnVrfRouteNextHopAddrType	The address type of the next hop IP address. This MIB implementation only supports only IPv4 (1). Therefore, this object has a value of "ipv4 (1)."
mplsVpnVrfRouteIfIndex	The interface MIB ifIndex for the interface through which this route is forwarded. The object is 0 if no interface is defined for the route.
mplsVpnVrfRouteType	Defines if this route is a local or remotely defined route.
mplsVpnVrfRouteProto	The routing protocol that was responsible for adding this route to the VRF.
mplsVpnVrfRouteAge	The number of seconds since this route was last updated.
mplsVpnVrfRouteInfo	A pointer to more information from other MIBs. This object is not supported and always returns "nullOID (0.0)."
mplsVpnVrfRouteNextHopAS	The autonomous system number of the next hop for this route. This object is not supported and is always 0.
mplsVpnVrfRouteMetric1	The primary routing metric used for this route.
mplsVpnVrfRouteMetric2 mplsVpnVrfRouteMetric3 mplsVpnVrfRouteMetric4 mplsVpnVrfRouteMetric5	Alternate routing metrics used for this route. These objects are supported only for Cisco Interior Gateway Routing Protocol (IGRP) and Cisco Enhanced Interior Gateway Routing Protocol (EIGRP). These objects display the bandwidth metrics used for the route. Otherwise, these values are set to -1.
mplsVpnVrfRouteRowStatus	Read-only implementation. This object normally reads "active (1)," but may read "notInService (2)," if a VRF was recently deleted.
mplsVpnVrfRouteStorageType	Read-only implementation. This object always reads "volatile (2)."

PPVPN-MPLS-VPN MIB Notifications

This section provides the following information about supported PPVPN-MPLS-VPN MIB notifications:

PPVPN-MPLS-VPN MIB Notification Events

The following notifications of the PPVPN-MPLS-VPN MIB are supported:

- mplsVrfIfUp--Sent to an NMS when an interface comes up and is assigned a VRF instance.

- `mplsVrfIfDown`--Generated and sent to the NMS when a VRF is removed from an interface or the interface transitions from an operationally “up” state to a “down” state.
- `mplsNumVrfRouteMidThreshExceeded`--Generated and sent when the middle (warning) threshold is crossed. You can configure this threshold in the CLI by using the following commands:

```
Router(config)# ip vrf vrf-name
Router(config-vrf)# maximum routes limit warn-threshold (% of max)
```

The *warn-threshold* argument is a percentage of the maximum routes specified by the *limit* argument. You can also configure a middle threshold with the following command, in which the *limit* argument represents the warning threshold:

```
Router(config-vrf)# maximum routes limit warn-threshold (% of max)
```

This notification is sent to the NMS only at the time the threshold is exceeded. (See the figure below for a comparison of the warning and maximum thresholds.) Whenever the number of routes falls below this threshold and exceeds the threshold again, a notification is sent to the NMS.

- `MplsNumVrfRouteMaxThreshExceeded`--Generated and sent when you attempt to create a route on a VRF that already contains the maximum number of routes as defined by the *limit* argument of the **maximum routes** commands:

```
Router(config)# ip vrf vrf-name
Router(config-vrf)# maximum routes limit warn-threshold (% of max)
```

A trap notification is sent to the NMS when you attempt to exceed the maximum threshold. Another `MplsNumVrfRouteMaxThreshExceeded` notification is not sent until the number of routes falls below the maximum threshold and reaches the maximum threshold again. (See the figure below for an example of how this notification works and for a comparison of the maximum and warning thresholds.)



Note

The **maximum routes** command sets the number of routes for a VRF. You *cannot* exceed the number of routes in the VRF that you set with the **maximum routes limit warn-threshold** command. Prior to implementation of the PPVPN-MPLS-VPN MIB, you were not notified when this threshold (or the warning threshold) was reached.

- `mplsNumVrfSecIllegalLabelThreshExceeded`--Generated and sent when the number of illegal labels received on a VRF interface exceeds the threshold `mplsVpnVrfSecIllegalLabelRcvThresh`. This threshold is defined with a value of 0. Therefore, a notification is sent when the first illegal label is received on a VRF. Labels are considered illegal if they are outside of the valid label range, do not have a Label Forwarding Information Base (LFIB) entry, or the table ID of the message does not match the table ID for the label in the LFIB.

CISCO-IETF-PPVPN-MPLS-VPN MIB Notification Events

The following notification of the CISCO-IETF-PPVPN-MPLS-VPN MIB is supported in Cisco software:

- `cMplsNumVrfRouteMaxThreshCleared`--Generated and sent when the number of routes on a VRF attempts to exceed the maximum number of routes and then drops below the maximum number of routes. If you attempt to create a route on a VRF that already contains the maximum number of routes, the `mplsNumVrfRouteMaxThreshExceeded` notification is sent (if enabled). When you remove routes from

the VRF so that the number of routes falls below the set limit, the `cMplsNumVrfRouteMaxThreshCleared` notification is sent. You can clear all routes from the VRF by using the `clear ip route vrf` command. (See the figure below to see when the `cMplsNumVrfRouteMaxThreshCleared` notification is sent.)

Figure 5: Comparison of Warning and Maximum Thresholds

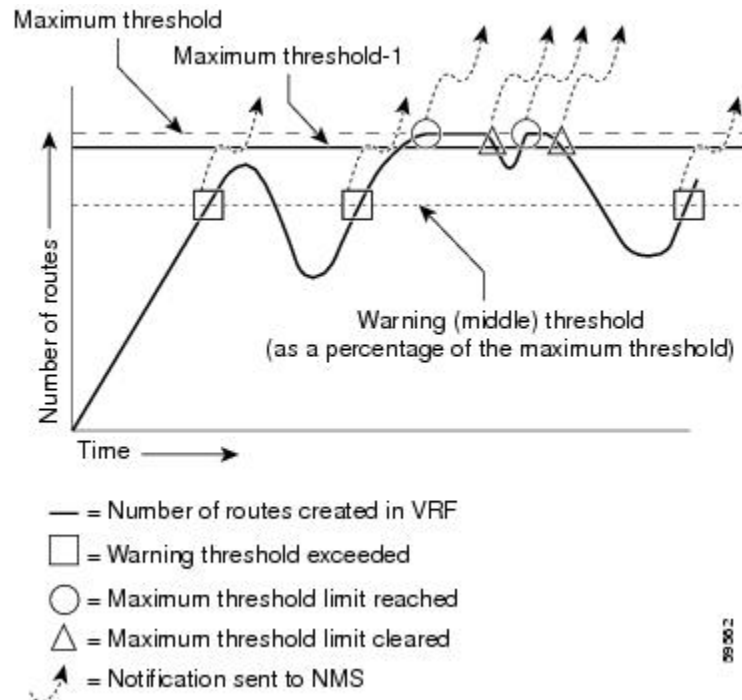

Notification Specification

In an SNMPv1 notification, each VPN notification has a generic type identifier and an enterprise-specific type identifier for identifying the notification type.

- The generic type for all VPN notifications is “enterpriseSpecific” because this is not one of the generic notification types defined for SNMP.
- The enterprise-specific type is identified as follows:
 - 1 for `mplsVrffUp`
 - 2 for `mplsVrffDown`
 - 3 for `mplsNumVrfRouteMidThreshExceeded`
 - 4 for `mplsNumVrfRouteMaxThreshExceeded`
 - 5 for `mplsNumVrfSecIllegalLabelThreshExceeded`
 - 6 for `cMplsNumVrfRouteMaxThreshCleared`

In SNMPv2, the notification type is identified by an `SnmpTrapOID` varbind (variable binding consisting of an object identifier [OID] type and value) included within the notification message.

Each notification also contains two additional objects from the PPVPN-MPLS-VPN MIB. These objects provide additional information about the event, as follows:

- The VRF interface up/down notifications provide additional variables--*mplsVpnInterfaceConfIndex* and *mplsVpnVrfName*-- in the notification. These variables describe the SNMP interface index and the VRF name, respectively.
- The mid and max threshold notifications include the *mplsVpnVrfName* variable (VRF name) and the *mplsVpnVrfPerfCurrNumRoutes* variable that indicates the current number of routes within the VRF.
- The illegal label notification includes the *mplsVpnVrfName* variable (VRF name) and the *mplsVpnVrfSecIllegalLabelViolations* variable that maintains the current count of illegal labels on a VPN.

Monitoring the PPVPN-MPLS-VPN MIB Notifications

When PPVPN-MPLS-VPN MIB notifications are enabled (see the **snmp-server enable traps mpls vpn** command in the Cisco IOS Multiprotocol Label Switching Command Reference), notification messages relating to specific MPLS VPN events within Cisco software are generated and sent to a specified NMS in the network. Any utility that supports SNMPv1 or SNMPv2 notifications can receive notification messages.

To monitor PPVPN-MPLS-VPN MIB notification messages, log in to an NMS that supports a utility that displays SNMP notifications, and start the display utility.

Unsupported Objects in PPVPN-MPLS-VPN MIB

The following objects from the *mplsVpnVrfBgpPathAttrTable* are not supported with SNMP management for MPLS VPN features in Cisco software:

- *mplsVpnVrfBgpPathAttrPeer*
- *mplsVpnVrfBgpPathAttrIpAddrPrefixLen*
- *mplsVpnVrfBgpPathAttrIpAddrPrefix*
- *mplsVpnVrfBgpPathAttrOrigin*
- *mplsVpnVrfBgpPathAttrASPathSegment*
- *mplsVpnVrfBgpPathAttrNextHop*
- *mplsVpnVrfBgpPathAttrMultiExitDisc*
- *mplsVpnVrfBgpPathAttrLocalPref*
- *mplsVpnVrfBgpPathAttrAtomicAggregate*
- *mplsVpnVrfBgpPathAttrAggregatorAS*
- *mplsVpnVrfBgpPathAttrAggregatorAddr*
- *mplsVpnVrfBgpPathAttrCalcLocalPref*
- *mplsVpnVrfBgpPathAttrBest*
- *mplsVpnVrfBgpPathAttrUnknown*

How to Configure MPLS VPN--MIB Support

Configuring the SNMP Community

An SNMP community string defines the relationship between the SNMP manager and the agent. The community string acts like a password to regulate access to the agent on the router.

Perform this task to configure an SNMP community.

SUMMARY STEPS

1. **enable**
2. **show running-config** [*options*]
3. **configure terminal**
4. **snmp-server community** *string* [**view** *view-name*] [**ro** | **rw**] [*acl-number*]
5. **do copy running-config startup-config**
6. **exit**
7. **show running-config** [*options*]

DETAILED STEPS

	Command or Action	Purpose
Step 1	enable Example: <pre>Router> enable</pre>	Enables privileged EXEC mode. <ul style="list-style-type: none"> • Enter your password if prompted.
Step 2	show running-config [<i>options</i>] Example: <pre>Router# show running-config</pre>	Displays the running configuration to determine if an SNMP agent is already running. <ul style="list-style-type: none"> • If no SNMP information is displayed, continue with the next step. If any SNMP information is displayed, you can modify the information or change it as needed.
Step 3	configure terminal Example: <pre>Router# configure terminal</pre>	Enters global configuration mode.
Step 4	snmp-server community <i>string</i> [view <i>view-name</i>] [ro rw] [<i>acl-number</i>] Example: <pre>Router(config)# snmp-server community comaccess ro</pre>	Sets up the community access string to permit access to the SNMP protocol. <ul style="list-style-type: none"> • The <i>string</i> argument acts like a password and permits access to the SNMP protocol. • The view <i>view-name</i><i>view-name</i> keyword argument pair specifies the name of a previously defined view.

	Command or Action	Purpose
		<p>The view defines the objects available to the community.</p> <ul style="list-style-type: none"> • The ro keyword specifies read-only access. Authorized management stations are only able to retrieve MIB objects. • The rw keyword specifies read/write access. Authorized management stations are able to both retrieve and modify MIB objects. • The <i>acl-number</i> argument is an integer from 1 to 99 that specifies an access list of IP addresses that are allowed to use the community string to gain access to the SNMP agent.
Step 5	<p>do copy running-config startup-config</p> <p>Example:</p> <pre>Router(config)# do copy running-config startup-config</pre>	<p>Saves the modified configuration to NVRAM as the startup configuration file.</p> <ul style="list-style-type: none"> • The do command allows you to perform EXEC level commands in configuration mode.
Step 6	<p>exit</p> <p>Example:</p> <pre>Router(config)# exit</pre>	<p>Returns to privileged EXEC mode.</p>
Step 7	<p>show running-config [<i>options</i>]</p> <p>Example:</p> <pre>Router# show-running config include snmp-server</pre>	<p>(Optional) Displays the configuration information currently on the router, the configuration for a specific interface, or map-class information.</p> <ul style="list-style-type: none"> • Use the show running-config command to check that the snmp-server statements appear in the output.

Configuring the Router to Send SNMP Traps

Perform this task to configure the router to sendm SNMP traps to a host.

The **snmp-server host** command specifies which hosts receive traps. The **snmp-server enable traps** command globally enables the trap production mechanism for the specified traps.

For a host to receive a trap, an **snmp-server host** command must be configured for that host, and, generally, the trap must be enabled globally through the **snmp-server enable traps** command.



Note Although you can set the *community-string* argument using the **snmp-server host** command by itself, we recommend you define this string using the **snmp-server community** command before using the **snmp-server host** command.

SUMMARY STEPS

1. **enable**
2. **configure terminal**
3. **snmp-server host** *host-addr* [**traps** | **informs**] [**version** {**1** | **2c** | **3** [**auth** | **noauth** | **priv**]}] *community-string* [**udp-port** *port*] [*notification-type*] [**vrf** *vrf-name*]
4. **snmp-server enable traps mpls vpn** [**illegal-label**] [**max-thresh-cleared**] [**max-threshold**] [**mid-threshold**] [**vrf-down**] [**vrf-up**]
5. **end**

DETAILED STEPS

	Command or Action	Purpose
Step 1	enable Example: Router> enable	Enables privileged EXEC mode. <ul style="list-style-type: none"> • Enter your password if prompted.
Step 2	configure terminal Example: Router# configure terminal	Enters global configuration mode.
Step 3	snmp-server host <i>host-addr</i> [traps informs] [version { 1 2c 3 [auth noauth priv]}] <i>community-string</i> [udp-port <i>port</i>] [<i>notification-type</i>] [vrf <i>vrf-name</i>] Example: Router(config)# snmp-server host 172.20.2.160 traps comaccess mpls-vpn	Specifies the recipient of an SNMP notification operation. <ul style="list-style-type: none"> • The <i>host-addr</i> argument specifies the name or Internet address of the host (the targeted recipient). • The traps keyword sends SNMP traps to this host. This is the default. • The informs keyword sends SNMP informs to this host. • The version keyword specifies the version of the SNMP used to send the traps. Version 3 is the most secure model, because it allows packet encryption with the priv keyword. If you use the version keyword, you must specify one of the following: <ul style="list-style-type: none"> • 1--SNMPv1. This option is not available with informs. • 2c --SNMPv2C. • 3--SNMPv3. The following three optional keywords can follow the version 3 keyword (auth, noauth, priv). • The <i>community-string</i> argument is a password-like community string sent with the notification operation. • The udp-port <i>port</i> keyword and argument pair names the User Datagram Protocol (UDP) port of the host to use. The default is 162.

	Command or Action	Purpose
		<ul style="list-style-type: none"> The <i>notification-type</i> argument specifies the type of notification to be sent to the host. If no type is specified, all notifications are sent. The vrf <i>vrf-name</i> keyword and argument pair specifies the VRF table that should be used to send SNMP notifications.
Step 4	<p>snmp-server enable traps mpls vpn [illegal-label] [max-thresh-cleared] [max-threshold] [mid-threshold] [vrf-down] [vrf-up]</p> <p>Example:</p> <pre>Router(config)# snmp-server enable traps mpls vpn vrf-down vrf-up</pre>	<p>Enables the router to send MPLS VPN-specific SNMP notifications (traps and informs).</p> <ul style="list-style-type: none"> The illegal-label keyword enables a notification for any illegal labels received on a VRF interface. Labels are illegal if they are outside the legal range, do not have an LFIB entry, or do not match table IDs for the label. The max-thresh-cleared keyword enables a notification when the number of routes falls below the limit after the maximum route limit was attempted. The max-threshold keyword enables a notification that a route creation attempt was unsuccessful because the maximum route limit was reached. Another <code>MplsNumVrfRouteMaxThreshExceeded</code> notification is not sent until the number of routes falls below the maximum threshold and reaches the maximum threshold again. The max-threshold value is determined by the maximum routes command in VRF configuration mode. The mid-threshold keyword enables a notification of a warning that the number of routes created has crossed the warning threshold. This warning is sent only at the time the warning threshold is exceeded. The vrf-down keyword enables a notification for the removal of a VRF from an interface or the transition of an interface to the down state. The vrf-up keyword enables a notification for the assignment VRF to an interface that is operational or for the transition of a VRF interface to the operationally up state.
Step 5	<p>end</p> <p>Example:</p> <pre>Router(config)# end</pre>	(Optional) Exits to privileged EXEC mode.

Configuring Threshold Values for MPLS VPN--SNMP Notifications

Perform this task to configure the following threshold values for MPLS VPN--SNMP notifications:

- The `mplsNumVrfRouteMidThreshExceeded` notification event is generated and sent when the middle (warning) threshold is crossed. You can configure this threshold in the CLI by using the **maximum routes** command in VRF configuration mode. This notification is sent to the NMS only at the time the threshold is exceeded. Whenever the number of routes falls below this threshold and exceeds the threshold again, a notification is sent to the NMS.
- The `mplsNumVrfRouteMaxThreshExceeded` notification event is generated and sent when you attempt to create a route on a VRF that already contains the maximum number of routes as defined by the **maximum routes** command in VRF configuration mode. A trap notification is sent to the NMS when you attempt to exceed the maximum threshold. Another `MplsNumVrfRouteMaxThreshExceeded` notification is not sent until the number of routes falls below the maximum threshold and reaches the maximum threshold again.

See the figure above for an example of how this notification works and for a comparison of the maximum and warning thresholds.



Note The **maximum routes** command sets the number of routes for a VRF. You *cannot* exceed the number of routes in the VRF that you set with the **maximum routes limit warn-threshold** command. Prior to the implementation of the PPVPN-MPLS-VPN MIB, you were not notified when this threshold (or the warning threshold) was reached.

SUMMARY STEPS

1. **enable**
2. **configure terminal**
3. **ip vrf *vrf-name***
4. **maximum routes limit {*warn-threshold* | **warn-only**}**
5. **end**

DETAILED STEPS

	Command or Action	Purpose
Step 1	enable Example: Router> enable	Enables privileged EXEC mode. • Enter your password if prompted.
Step 2	configure terminal Example: Router# configure terminal	Enters global configuration mode.
Step 3	ip vrf <i>vrf-name</i> Example:	Configures a VRF routing table and enters VRF configuration mode.

	Command or Action	Purpose
	Router(config)# ip vrf vpn1	<ul style="list-style-type: none"> The <i>vrf-name</i> argument specifies the name assigned to a VRF.
Step 4	maximum routes <i>limit</i> { <i>warn-threshold</i> warn-only } Example: Router(config-vrf)# maximum routes 10000 80	Limits the maximum number of routes in a VRF to prevent a PE router from importing too many routes. <ul style="list-style-type: none"> The <i>limit</i> argument specifies the maximum number of routes allowed in a VRF. The range is from 1 to 4,294,967,295. The <i>warn-threshold</i> argument generates a warning when the number of routes set by the <i>warn-threshold</i> argument is reached and rejects routes that exceed the maximum number set in the <i>limit</i> argument. The warning threshold is a percentage from 1 to 100 of the maximum number of routes specified in the <i>limit</i> argument. The warn-only keyword specifies that a system logging error message is issued when the maximum number of routes allowed for a VRF exceeds the limit threshold. However, additional routes are still allowed.
Step 5	end Example: Router(config-vrf)# end	(Optional) Exits to privileged EXEC mode.

Configuration Examples for MPLS VPN--MIB Support

Example Configuring the SNMP Community

The following example shows enabling a simple SNMP community group. This configuration permits any SNMP client to access all PPVPN-MPLS-VPN MIB objects with read-only access using the community string comaccess.

```
Router# configure terminal
Router(config)# snmp-server community comaccess ro
```

Verify that the SNMP master agent is enabled for the MPLS VPN--MIB Support feature:

```
Router# show running-config | include snmp-server
Building configuration...
.
snmp-server community comaccess RO
```



Note If you do not see any “snmp-server” statements, SNMP is not enabled on the router.

Example Configuring the Router to Send SNMP Traps

The following example shows you how to enable the router to send MPLS VPN notifications to host 172.20.2.160 using the comaccess community string if a VRF transitions from an up or down state:

```
Router# configure terminal
Router(config)# snmp-server host 172.20.2.160 traps comaccess mpls-vpn
Router(config)# snmp-server enable traps mpls vpn vrf-down vrf-up
```

Example Configuring Threshold Values for MPLS VPN--SNMP Notifications

The following example shows how to set a maximum threshold of 10,000 routes and a warning threshold that is 80 percent of the maximum threshold for a VRF named vpn1 on a router:

```
Router(config)# ip vrf vpn1
Router(config-vrf)# maximum routes 10000 80
```

The following example shows how to set a warning threshold of 10,000 routes for a VRF named vpn2 on a router. An error message is generated; however, additional routes are still allowed because a maximum route threshold is not set with this command.

```
Router(config)# ip vrf vpn2
Router(config-vrf)# maximum routes 10000 warn-only
```

Additional References

Related Documents

Related Topic	Document Title
Cisco IOS commands	Cisco IOS Master Commands List, All Releases
Description of commands associated with MPLS and MPLS applications	<i>Cisco IOS Multiprotocol Label Switching Command Reference</i>
MPLS VPN configuration tasks	Configuring MPLS Layer 3 VPNs
A description of SNMP agent support in Cisco software for the MPLS Traffic Engineering MIB (MPLS TE MIB)	MPLS Traffic Engineering (TE) MIB
Overview and configuration tasks for the MPLS distribution protocol	MPLS Label Distribution Protocol

Standards

Standard	Title
draft-ietf-ppvpn-mpls-vpn-mib-05	<i>MPLS/BGP Virtual Private Network Management Information Base Using SMIv2</i>

MIBs

MIB	MIBs Link
<ul style="list-style-type: none"> • MPLS-VPN-MIB • CISCO-IETF-PPVPN-MPLS-VPN-MIB 	To locate and download MIBs for selected platforms, Cisco software releases, and feature sets, use Cisco MIB Locator found at the following URL: http://www.cisco.com/go/mibs

RFCs

RFC	Title
RFC 2233	<i>The Interfaces Group MIB using SMIv2</i>
RFC 2547	<i>BGP/MPLS VPNs</i>

Technical Assistance

Description	Link
The Cisco Support and Documentation website provides online resources to download documentation, software, and tools. Use these resources to install and configure the software and to troubleshoot and resolve technical issues with Cisco products and technologies. Access to most tools on the Cisco Support and Documentation website requires a Cisco.com user ID and password.	http://www.cisco.com/cisco/web/support/index.html

Feature Information for MPLS VPN--MIB Support

The following table provides release information about the feature or features described in this module. This table lists only the software release that introduced support for a given feature in a given software release train. Unless noted otherwise, subsequent releases of that software release train also support that feature.

Use Cisco Feature Navigator to find information about platform support and Cisco software image support. To access Cisco Feature Navigator, go to www.cisco.com/go/cfn. An account on Cisco.com is not required.

Table 9: Feature Information for MPLS VPN--MIB Support

Feature Name	Releases	Feature Information
MPLS VPN--MIB Support	Cisco IOS XE Release 2.1	The following command was introduced or modified: snmp-server enable traps mpls vpn

Glossary

6VPE router—Provider edge router that provides BGP-MPLS IPv6 VPN service over an IPv4-based MPLS core. It is a IPv6 VPN PE, dual-stack router that implements 6PE concepts on the core-facing interfaces.

autonomous system—A collection of networks that share the same routing protocol and that are under the same system administration.

ASN.1 —Abstract Syntax Notation One. The data types independent of particular computer structures and representation techniques. Described by ISO International Standard 8824.

BGP —Border Gateway Protocol. The exterior Border Gateway Protocol used to exchange routing information between routers in separate autonomous systems. BGP uses TCP. Because TCP is a reliable protocol, BGP does not experience problems with dropped or fragmented data packets.

BGP prefixes—A route announcement using the BGP. A prefix is composed of a path of autonomous system numbers, indicating which networks the packet must pass through, and the IP block that is being routed. A BGP prefix would look something like: 701 1239 42 206.24.14.0/24. (The /24 part is referred to as a CIDR mask.) The /24 indicates that there are 24 ones in the netmask for this block starting from the left side. A /24 corresponds to the natural mask 255.255.255.0.

CE router—customer edge router. A router on the border between a VPN provider and a VPN customer that belongs to the customer.

CIDR —classless interdomain routing. A technique supported by BGP4 and based on route aggregation. CIDR allows routers to group routes to reduce the quantity of routing information carried by the core routers. With CIDR, several IP networks appear to networks outside the group as a single, larger entity. With CIDR, IP addresses and their subnet masks are written as four octets, separated by periods, followed by a forward slash and a two-digit number that represents the subnet mask.

Cisco Express Forwarding—An advanced Layer 3 IP switching technology. Cisco Express Forwarding optimizes network performance and scalability for networks with large and dynamic traffic patterns.

community —In SNMP, a logical group of managed devices and NMSs in the same administrative domain.

community name—*See* community string.

community string—A text string that acts as a password and is used to authenticate messages sent between a managed station and a router containing an SNMP agent. The community string is sent in every packet between the manager and the client. Also called a community name.

IETF —Internet Engineering Task Force. A task force consisting of over 80 working groups responsible for developing Internet standards. The IETF operates under the auspices of ISOC. *See also* ISOC.

informs —A type of notification message that is more reliable than a conventional trap notification message, because the informs message notification requires acknowledgment, and a trap notification does not.

ISOC —Internet Society. An international nonprofit organization, founded in 1992, that coordinates the evolution and use of the Internet. In addition, ISOC delegates authority to other groups related to the Internet, such as the IAB. ISOC is headquartered in Reston, Virginia (United States).

label —A short, fixed-length data construct that tells switching nodes how to forward data (packets or cells).

LDP —Label Distribution Protocol. A standard protocol between MPLS-enabled routers that is used for the negotiation of the labels (addresses) used to forward packets.

LFIB —Label Forwarding Information Base. In the Cisco Label Switching system, the data structure for storing information about incoming and outgoing tags (labels) and associated equivalent packets suitable for labeling.

LSR —label switch router. A device that forwards MPLS packets based on the value of a fixed-length label encapsulated in each packet.

MIB —Management Information Base. A database of network management information that is used and maintained by a network management protocol such as SNMP or CMIP. The value of a MIB object can be changed or retrieved using SNMP or CMIP commands, usually through a GUI network management system. MIB objects are organized in a tree structure that includes public (standard) and private (proprietary) branches.

MPLS —Multiprotocol Label Switching. A method for forwarding packets (frames) through a network. It enables routers at the edge of a network to apply labels to packets (frames). ATM switches or existing routers in the network core can switch packets according to the labels with minimal lookup overhead.

MPLS interface—An interface on which MPLS traffic is enabled.

MPLS VPN—Multiprotocol Label Switching Virtual Private Network. An IP network infrastructure delivering private network services over a public infrastructure using a Layer 3 backbone. Using MPLS VPNs in a Cisco IOS network provides the capability to deploy and administer scalable Layer 3 VPN backbone services including applications, data hosting network commerce, and telephony services to business customers.

For an MPLS VPN solution, an MPLS VPN is a set of provider edge routers that are connected by means of a common “backbone” network to supply private IP interconnectivity between two or more customer sites for a given customer. Each VPN has a set of provisioning templates and policies and can span multiple provider administrative domains (PADs).

NMS —network management system. A powerful, well-equipped computer (typically an engineering workstation) that is used by a network administrator to communicate with other devices in the network. An NMS is typically used to manage network resources, gather statistics, and perform a variety of network administration and configuration tasks.

notification —A message sent by an SNMP agent to a network management station, console, or terminal to indicate that a significant event within Cisco IOS software has occurred. *See also* trap.

PE router—provider edge router. A router on the border between a VPN provider and a VPN customer that belongs to the provider.

QoS —quality of service. A measure of performance for a transmission system that reflects its transmission quality and service availability.

RIB —Routing Information Base. Also called the routing table.

RT —route target. An extended community attribute that identifies a group of routers and, in each router of that group, a subset of forwarding tables maintained by the router that can be populated with a BGP route carrying that extended community attribute. The RT is a 64-bit value by which Cisco IOS software discriminates routes for route updates in VRFs.

SNMP—Simple Network Management Protocol. The network management protocol used almost exclusively in TCP/IP networks. SNMP provides a means to monitor and control network devices, and to manage configurations, statistics collection, performance, and security. *See also* SNMP2.

SNMP2—SNMP Version 2. Version 2 of the popular network management protocol. SNMP2 supports centralized and distributed network management strategies, and includes improvements in the Structure of Management Information (SMI), protocol operations, management architecture, and security. *See also* SNMP.

trap—A message sent by an SNMP agent to a network management station, console, or terminal, indicating that a significant event occurred. Traps (notifications) are less reliable than inform requests, because the receiver does not send an acknowledgment when it receives a trap. The sender cannot determine if the trap was received. *See also* notification.

VPN—Virtual Private Network. A group of sites that, as the result of a set of administrative policies, are able to communicate with each other over a shared backbone network. A VPN is a secure IP-based network that shares resources on one or more physical networks. A VPN contains geographically dispersed sites that can communicate securely over a shared backbone. *See also* MPLS VPN.

VPN ID—A mechanism that identifies a VPN based on RFC 2685. A VPN ID consists of an Organizational Unique Identifier (OUI), a three-octet hex number assigned by the IEEE Registration Authority, and a VPN index, a four-octet hex number, which identifies the VPN within the company.

VRF—VPN routing and forwarding instance. A VRF consists of an IP routing table, a derived forwarding table, a set of interfaces that use the forwarding table, and a set of rules and routing protocols that determine what goes into the forwarding table. In general, a VRF includes the routing information that defines a customer VPN site that is attached to a PE router.

