



Cisco IOS Switching Paths Overview

Last Updated: October 6, 2011

This module provides an overview of the switching paths that can be configured on Cisco IOS devices.

- [Finding Feature Information, page 1](#)
- [Information About IOS Switching Paths, page 1](#)
- [How to Configure Cisco IOS Switching Paths Overview, page 8](#)
- [Configuration Examples for Cisco IOS Switching Paths Overview, page 8](#)
- [Additional References, page 8](#)
- [Feature Information for the Cisco IOS Switching Paths Overview, page 10](#)
- [Glossary, page 10](#)

Finding Feature Information

Your software release may not support all the features documented in this module. For the latest feature information and caveats, see the release notes for your platform and software release. To find information about the features documented in this module, and to see a list of the releases in which each feature is supported, see the Feature Information Table at the end of this document.

Use Cisco Feature Navigator to find information about platform support and Cisco software image support. To access Cisco Feature Navigator, go to www.cisco.com/go/cfn. An account on Cisco.com is not required.

Information About IOS Switching Paths

- [Basic Router Platform Architecture and Processes, page 2](#)
- [Cisco Routing and Switching Processes, page 2](#)
- [Basic Switching Paths, page 4](#)
- [Features That Affect Performance, page 7](#)



Americas Headquarters:
Cisco Systems, Inc., 170 West Tasman Drive, San Jose, CA 95134-1706 USA

Basic Router Platform Architecture and Processes

To understand how switching works, it helps to first understand the basic router architecture and where various processes occur in the router.



Note

IP unicast fast switching is not supported on Cisco IOS 12.2S, 12.2SB, 12.2SR, and 12.2SX releases.

Fast switching is enabled by default on all interfaces that support fast switching. If you have a situation where you need to disable fast switching and fall back to the process-switching path, understanding how various processes affect the router and where they occur will help you determine your alternatives. This understanding is especially helpful when you are troubleshooting traffic problems or need to process packets that require special handling. Some diagnostic or control resources are not compatible with fast switching or come at the expense of processing and switching efficiency. Understanding the effects of those resources can help you minimize their effect on network performance.

The figure below illustrates a possible internal configuration of a Cisco 7500 series router. In this configuration, the Cisco 7500 series router has an integrated Route Switch Processor (RSP) and uses *route caching* to forward packets. The Cisco 7500 series router also uses Versatile Interface Processors (VIPs), a RISC-based interface processor that receives and caches routing information from the RSP. The VIP card uses the route cache to make switching decisions locally, which relieves the RSP of involvement and speeds overall throughput. This type of switching is called distributed switching. Multiple VIP cards can be installed in one router.

Figure 1 Basic Router Architecture

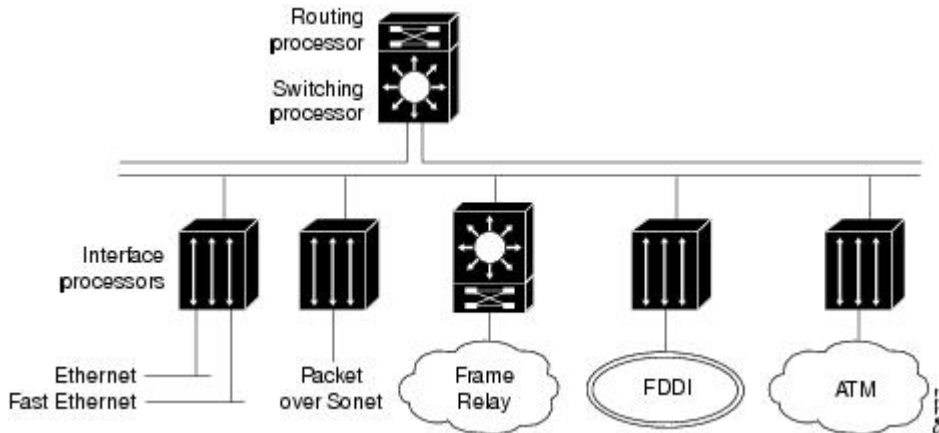

Cisco Routing and Switching Processes

The routing, or forwarding, function comprises two interrelated processes to move information in the network:

- Making a routing decision by routing
- Moving packets to the next hop destination by switching

Cisco IOS platforms perform both routing and switching, and there are several types of each:

- [Routing Processes, page 3](#)
- [Selective Packet Discard Manages Routing Protocol Packets, page 3](#)

- [Switching Processes, page 3](#)

Routing Processes

The routing process assesses the source and destination of traffic based on knowledge of network conditions. Routing functions identify the best path to use for moving the traffic to the destination out one or more of the router interfaces. The routing decision is based on various criteria such as link speed, topological distance, and protocol. Each protocol maintains its own routing information.

Routing is more processing intensive and has higher latency than switching as it determines path and next hop considerations. The first packet routed requires a lookup in the routing table to determine the route. The route cache is populated after the first packet is routed by the route-table lookup. Subsequent traffic for the same destination is switched using the routing information stored in the route cache.

The figure below illustrates the basic routing process.

Figure 2 **The Routing Process**

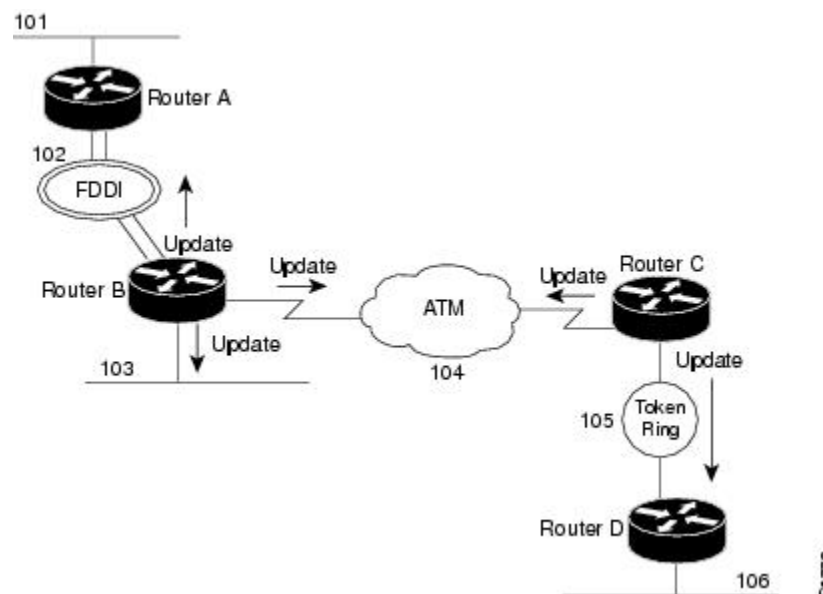

A router sends routing updates out each of its interfaces that are configured for a particular protocol. It also receives routing updates from other attached routers. From these received updates and its knowledge of attached networks, it builds a map of the network topology.

Selective Packet Discard Manages Routing Protocol Packets

When in severe overload conditions, routers that cannot keep up with the incoming packet stream must drop packets. If no intelligence is applied to choosing which packets to discard, the stability of routing protocols is impacted. The Selective Packet Discard (SPD) feature applies some simple choices to selectively discard packets likely to be unimportant for routing and interface stability. SPD is enabled by default; there are no commands or configuration tasks required.

Switching Processes

Through the switching process, the router determines the next hop toward the destination address. Switching moves traffic from an input interface to one or more output interfaces. Switching is optimized

and has lower latency than routing because it can move packets, frames, or cells from buffer to buffer with simpler determination of the source and destination of the traffic. It saves resources because it does not involve extra lookups. The figure below illustrates the basic switching process.

Figure 3 The Switching Process

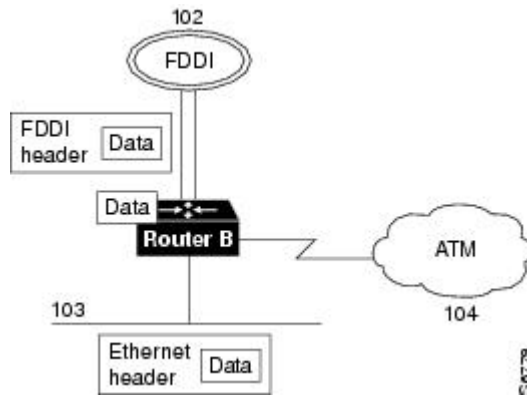

In the figure below, packets are received on the Fast Ethernet interface and destined for the FDDI interface. Based on information in the packet header and destination information stored in the routing table, the router determines the destination interface. It looks in the routing table of the protocol to discover the destination interface that services the destination address of the packet.

The destination address is stored in tables such as ARP tables for IP or AARP tables for AppleTalk. If there is no entry for the destination, the router will either drop the packet (and inform the user if the protocol provides that feature) or discover the destination address by some other address resolution process, such as through ARP. Layer 3 IP addressing information is mapped to the Layer 2 MAC address for the next hop. The figure below illustrates the mapping that occurs to determine the next hop.

Figure 4 Layer 3-to-Layer 2 Mapping

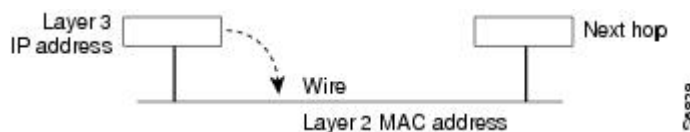

Basic Switching Paths

- [Process Switching, page 4](#)
- [Fast Switching, page 5](#)
- [Cisco Express Forwarding Switching, page 5](#)
- [Distributed Cisco Express Forwarding Switching, page 5](#)
- [Platform and Switching Path Correlation, page 6](#)

Process Switching

In process switching the first packet is copied to the system buffer. The router looks up the Layer 3 network address in the routing table and initializes the fast-switch cache. The frame is rewritten with the destination address and sent to the outgoing interface that services that destination. Subsequent packets for that

destination are sent by the same switching path. The route processor computes the cyclical redundancy check (CRC).

Fast Switching

When packets are fast switched, the first packet is copied to packet memory and the destination network or host is found in the fast-switching cache. The frame is rewritten and sent to the outgoing interface that services the destination. Subsequent packets for the same destination use the same switching path. The interface processor computes the CRC. Fast switching is described in the Configuring Fast Switching module.

**Note**

IP unicast fast switching is not supported on Cisco IOS 12.2S releases.

Cisco Express Forwarding Switching

When Cisco Express Forwarding mode is enabled, the Cisco Express Forwarding Forwarding Information Base (FIB) and adjacency tables reside on the Route Processor (RP), and the RP performs the express forwarding. You can use Cisco Express Forwarding mode when line cards are not available for Cisco Express Forwarding switching or when you need to use features not compatible with distributed Cisco Express Forwarding switching. For information on configuring Cisco Express Forwarding, see the Cisco Express Forwarding Overview module.

**Note**

Beginning with Cisco IOS Release 12.0, Cisco Express Forwarding is the preferred and default switching path. NetFlow switching has been integrated into Cisco Express Forwarding switching. For more information, see the Cisco Express Forwarding Overview module.

Distributed Cisco Express Forwarding Switching

In distributed switching, the switching process occurs on VIP and other interface cards that support switching. When distributed Cisco Express Forwarding is enabled, line cards, such as VIP line cards or GSR line cards, maintain an identical copy of the FIB and adjacency tables. The line cards perform the express forwarding between port adapters, relieving the RSP of involvement in the switching operation. distributed Cisco Express Forwarding uses an Inter Process Communication (IPC) mechanism to ensure synchronization of FIBs and adjacency tables on the RP and line cards.

For model numbers and hardware compatibility information, refer to the *Cisco Product Catalog*. For information on configuring distributed Cisco Express Forwarding, see the Cisco Express Forwarding Overview module.

For information on configuring Multicast Distributed Switching (MDS), see the Configuring Multicast Distributed Switching module.

The figure below illustrates the distributed switching process on the Cisco 7500 series.

Figure 5 Distributed Switching on Cisco 7500 Series Routers

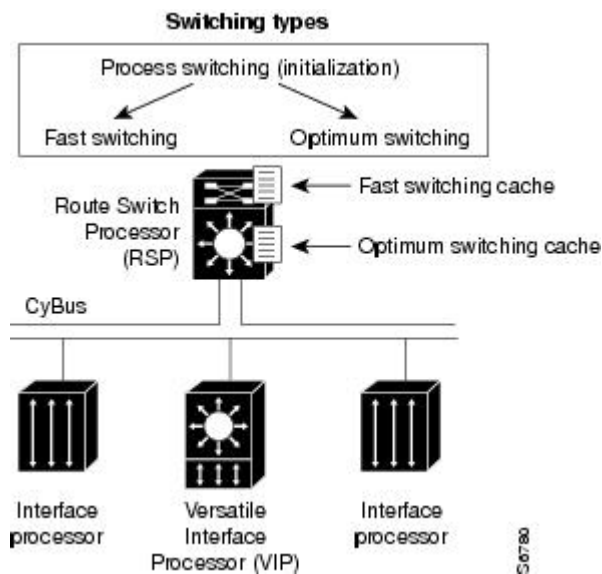

The VIP card installed in this router maintains a copy of the routing cache information needed to forward packets. Because the VIP card has the routing information it needs, it performs the switching locally, making the packet forwarding much faster. Router throughput is increased linearly based on the number of VIP cards installed in the router.

Platform and Switching Path Correlation

Depending on the routing platform you are using, availability and default implementations of switching paths varies. The table below shows the correlation between Cisco IOS switching paths and routing platforms.

Table 1 Switching Paths on Cisco 7200 and Cisco 7500 Series Routers

Switching Path	Cisco 7200 Series	Cisco 7500 Series	Comments	Configuration Command
Process switching	Yes	Yes	Initializes switching caches	no protocol route-cache
Fast switching	Yes	Yes	Default (except for IP unicast)	protocol route-cache
Cisco Express Forwarding switching	Yes	Yes	Default for IP	protocol route-cache cef

Switching Path	Cisco 7200 Series	Cisco 7500 Series	Comments	Configuration Command
distributed Cisco Express Forwarding switching	No	Yes	Using second-generation VIP line cards	<i>protocol route-cache cef distributed</i>

Features That Affect Performance

Performance is derived from the switching mechanism you are using. Some Cisco IOS features require special handling and cannot be switched until the additional processing they require has been performed. This special handling is not processing that the interface processors can do. Because these features require additional processing, they affect switching performance. These features include the following:

For information on Quality of Service (QoS) performance, refer to the *Cisco IOS Quality of Service Solutions Configuration Guide*.

- [Queueing When Network Congestion Occurs, page 7](#)
- [Random Early Detection for Congestion Avoidance, page 7](#)
- [Compression Options Depending on Protocol You Are Using, page 7](#)
- [Filtering Using Access Lists, page 8](#)
- [Encryption Added For Security, page 8](#)
- [Accounting Feature Based on Protocol Used, page 8](#)

Queueing When Network Congestion Occurs

Queueing occurs when network congestion occurs. When traffic is moving well within the network, packets are sent as they arrive at the interface. Cisco IOS software implements four different queueing algorithms as follows:

- FIFO queueing--Packets are forwarded in the same order in which they arrive at the interface.
- Priority queueing (PQ)--Packets are forwarded based on an assigned priority. You can create priority lists and groups to define rules for assigning packets to priority queues.
- Custom queueing (CQ)--You can control a percentage of interface bandwidth for specified traffic by creating protocol queue lists and custom queue lists.
- Weighted fair queueing (WFQ)--WFQ provides automatic traffic priority management. Low-bandwidth sessions have priority over high-bandwidth sessions. High-bandwidth sessions are assigned weights. WFQ is the default for interfaces slower than 2.048 Mbps.

Random Early Detection for Congestion Avoidance

Random Early Detection (RED) is designed for congestion avoidance. Traffic is prioritized based on type of service (ToS), or precedence. This feature is available on T3, OC-3, and ATM interfaces.

Compression Options Depending on Protocol You Are Using

Depending on the protocol you are using, various compression options are available in Cisco IOS software. Refer to the Cisco IOS configuration guide for the protocol you are using to learn compression options available.

Filtering Using Access Lists

You can define access lists to control access to or from a router for a number of services. You could, for example, define an access list to prevent packets with a certain IP address from leaving a particular interface on a router. How access lists are used depends on the protocol. For information on access lists, refer to the appropriate Cisco IOS configuration guide for the protocol you are using.

Encryption Added For Security

Encryption algorithms are applied to data to alter its appearance, making it incomprehensible to those not authorized to see the data. For information about encryption features available with the Cisco IOS software, refer to the *Cisco IOS Security Configuration Guide*.

Accounting Feature Based on Protocol Used

You can configure accounting features to collect network data related to resource usage. The information you collect (in the form of statistics) can be used for billing, chargeback, and planning resource usage. Refer to the appropriate Cisco IOS configuration guide for the protocol you are using for information regarding accounting features you can use.

How to Configure Cisco IOS Switching Paths Overview

Cisco IOS switching path overview has no configuration tasks.

Configuration Examples for Cisco IOS Switching Paths Overview

Cisco IOS switching path overview has no configuration tasks and therefore no configuration examples.

Additional References

Related Documents

Related Topic	Document Title
Cisco IOS commands	Cisco IOS Master Commands List, All Releases
IP switching commands: complete command syntax, command modes, command history, defaults, usage guidelines, and examples.	<i>Cisco IOS IP Switching Command Reference</i>
Overview of the Cisco Express Forwarding feature	Cisco Express Forwarding Overview

Related Topic	Document Title
Tasks for enabling or disabling Cisco Express Forwarding or distributed Cisco Express Forwarding	Enabling or Disabling Cisco Express Forwarding or Distributed Cisco Express Forwarding to Customize Switching and Forwarding for Dynamic Network
Tasks for configuring a load-balancing scheme for Cisco Express Forwarding	Configuring a Load-Balancing Scheme for Cisco Express Forwarding Traffic
Tasks for configuring Cisco Express Forwarding consistency checkers	Configuring Cisco Express Forwarding Consistency Checkers for Route Processors and Line Cards
Tasks for configuring epochs for Cisco Express Forwarding tables	Configuring Epochs to Clear and Rebuild Cisco Express Forwarding and Adjacency Tables
Tasks for configuring and verifying Cisco Express Forwarding network accounting	Configuring Cisco Express Forwarding Network Accounting
Tasks for customizing the display of recorded Cisco Express Forwarding events	Customizing the Display of Recorded Cisco Express Forwarding Events
Tasks for configuring fast switching	Configuring Fast Switching
Tasks for configuring Multicast Distributed Switching	Configuring Multicast Distributed Switching

Standards

Standard	Title
No new or modified standards are supported by this feature, and support for existing standards has not been modified by this feature.	--

MIBs

MIB	MIBs Link
No new or modified MIBs are supported by this feature, and support for existing MIBs has not been modified by this feature.	To locate and download MIBs for selected platforms, Cisco IOS releases, and feature sets, use Cisco MIB Locator found at the following URL: http://www.cisco.com/go/mibs

RFCs

RFC	Title
No new or modified RFCs are supported by this feature, and support for existing RFCs has not been modified by this feature.	--

Technical Assistance

Description	Link
The Cisco Support and Documentation website provides online resources to download documentation, software, and tools. Use these resources to install and configure the software and to troubleshoot and resolve technical issues with Cisco products and technologies. Access to most tools on the Cisco Support and Documentation website requires a Cisco.com user ID and password.	http://www.cisco.com/cisco/web/support/index.html

Feature Information for the Cisco IOS Switching Paths Overview

The following table provides release information about the feature or features described in this module. This table lists only the software release that introduced support for a given feature in a given software release train. Unless noted otherwise, subsequent releases of that software release train also support that feature.

Use Cisco Feature Navigator to find information about platform support and Cisco software image support. To access Cisco Feature Navigator, go to www.cisco.com/go/cfn. An account on Cisco.com is not required.

Table 2 *Feature Information for Cisco IOS Switching Paths Overview*

Feature Name	Releases	Feature Information
This table is intentionally left blank because no features were introduced or modified in Cisco IOS Release 12.2(1) or later. This table will be updated when feature information is added to this module.	--	--

Glossary

adjacency --A relationship formed between selected neighboring routers and end nodes for the purpose of exchanging routing information. Adjacency is based upon the use of a common media segment by the routers and nodes involved.

Cisco Express Forwarding --A Layer 3 switching technology. Cisco Express Forwarding can also refer to central Cisco Express Forwarding mode, one of two modes of Cisco Express Forwarding operation. Cisco Express Forwarding enables a Route Processor (RP) to perform express forwarding. Distributed Cisco Express Forwarding is the other mode of Cisco Express Forwarding operation.

distributed Cisco Express Forwarding --A type of Cisco Express Forwarding switching in which line cards (such as Versatile Interface Processor (VIP) line cards) maintain identical copies of the forwarding

information base (FIB) and adjacency tables. The line cards perform the express forwarding between port adapters; this relieves the Route Switch Processor of involvement in the switching operation.

FIB --forwarding information base. A component of Cisco Express Forwarding. The router uses the FIB lookup table to make destination-based switching decisions during Cisco Express Forwarding operation. The router maintains a mirror image of the forwarding information in an IP routing table.

IPC --interprocess communication. The mechanism that enables the distribution of Cisco Express Forwarding tables from the Route Switch Processor (RSP) to the line card when the router is operating in distributed Cisco Express Forwarding mode.

LIB --label information base. A database used by a label switch router (LSR) to store labels learned from other LSRs, as well as labels assigned by the local LSR.

line card --A general term for an interface processor that can be used in various Cisco products. For example, a Versatile Interface Processor (VIP) is a line card for the Cisco 7500 series router.

MPLS --Multiprotocol Label Switching. An emerging industry standard for the forwarding of packets along the normal routing paths (sometimes called MPLS hop-by-hop forwarding).

RP --Route Processor. The processor module in the Cisco 7000 series routers that contains the CPU, system software, and most of the memory components that are used in the router. It is sometimes called a supervisory processor.

VIP --Versatile Interface Processor. An interface card used in Cisco 7000 and Cisco 7500 series routers. The VIP provides multilayer switching and runs Cisco IOS.

VPN --Virtual Private Network. The result of a router configuration that enables IP traffic to use tunneling to travel securely over a public TCP/IP network.

VRF --A Virtual Private Network (VPN) routing/forwarding instance. A VRF consists of an IP routing table, a derived forwarding table, a set of interfaces that use the forwarding table, and a set of rules and routing protocols that determine what goes into the forwarding table. In general, a VRF includes the routing information that defines a customer VPN site that is attached to a PE router.

Cisco and the Cisco Logo are trademarks of Cisco Systems, Inc. and/or its affiliates in the U.S. and other countries. A listing of Cisco's trademarks can be found at www.cisco.com/go/trademarks. Third party trademarks mentioned are the property of their respective owners. The use of the word partner does not imply a partnership relationship between Cisco and any other company. (1005R)

Any Internet Protocol (IP) addresses and phone numbers used in this document are not intended to be actual addresses and phone numbers. Any examples, command display output, network topology diagrams, and other figures included in the document are shown for illustrative purposes only. Any use of actual IP addresses or phone numbers in illustrative content is unintentional and coincidental.

© 2011 Cisco Systems, Inc. All rights reserved.