



IP Event Dampening

Last Updated: October 25, 2011

The IP Event Dampening feature introduces a configurable exponential decay mechanism to suppress the effects of excessive interface flapping events on routing protocols and routing tables in the network. This feature allows the network operator to configure a router to automatically identify and selectively dampen a local interface that is flapping.

- [Finding Feature Information, page 1](#)
- [Restrictions for IP Event Dampening, page 1](#)
- [Information About IP Event Dampening, page 2](#)
- [How to Configure IP Event Dampening, page 6](#)
- [Configuration Examples for IP Event Dampening, page 8](#)
- [Additional References, page 9](#)
- [Feature Information for IP Event Dampening, page 10](#)
- [Glossary, page 10](#)

Finding Feature Information

Your software release may not support all the features documented in this module. For the latest feature information and caveats, see the release notes for your platform and software release. To find information about the features documented in this module, and to see a list of the releases in which each feature is supported, see the Feature Information Table at the end of this document.

Use Cisco Feature Navigator to find information about platform support and Cisco software image support. To access Cisco Feature Navigator, go to www.cisco.com/go/cfn. An account on Cisco.com is not required.

Restrictions for IP Event Dampening

Subinterface Restrictions

Only primary interfaces can be configured with this feature. The primary interface configuration is applied to all subinterfaces by default. IP Event Dampening does not track the flapping of individual subinterfaces on an interface.



Americas Headquarters:
Cisco Systems, Inc., 170 West Tasman Drive, San Jose, CA 95134-1706 USA

Virtual Templates Not Supported

Copying a dampening configuration from virtual templates to virtual access interfaces is not supported because dampening has limited usefulness to existing applications that use virtual templates. Virtual access interfaces are released when an interface flaps, and new connections and virtual access interfaces are acquired when the interface comes up and is made available to the network. Since dampening states are attached to the interface, the dampening states would not survive an interface flap.

IPX Routing Protocols Not Supported

Internetwork Packet Exchange (IPX) protocols are not supported by the IP Event Dampening feature. However, IPX variants of these protocols will still receive up and down state event information when this feature is enabled. This should not create any problems or routing issues.

Information About IP Event Dampening

- [IP Event Dampening Overview, page 2](#)
- [Interface State Change Events, page 2](#)
- [Affected Components, page 4](#)
- [Network Deployments, page 5](#)
- [Benefits of IP Event Dampening, page 5](#)

IP Event Dampening Overview

Interface state changes occur when interfaces are administratively brought up or down or if an interface changes state. When an interface changes state or flaps, routing protocols are notified of the status of the routes that are affected by the change in state. Every interface state change requires all affected devices in the network to recalculate best paths, install or remove routes from the routing tables, and then advertise valid routes to peer routers. An unstable interface that flaps excessively can cause other devices in the network to consume substantial amounts of system processing resources and cause routing protocols to lose synchronization with the state of the flapping interface.

The IP Event Dampening feature introduces a configurable exponential decay mechanism to suppress the effects of excessive interface flapping events on routing protocols and routing tables in the network. This feature allows the network operator to configure a router to automatically identify and selectively dampen a local interface that is flapping. Dampening an interface removes the interface from the network until the interface stops flapping and becomes stable. Configuring the IP Event Dampening feature improves convergence times and stability throughout the network by isolating failures so that disturbances are not propagated. This, in turn, reduces the utilization of system processing resources by other devices in the network and improves overall network stability.

Interface State Change Events

This section describes the interface state change events of the IP Event Dampening feature. This feature employs a configurable exponential decay mechanism that is used to suppress the effects of excessive interface flapping or state changes. When the IP Event Dampening feature is enabled, flapping interfaces are dampened from the perspective of the routing protocol by filtering excessive route updates. Flapping interfaces are identified, assigned penalties, suppressed if necessary, and made available to the network when the interface stabilizes. Figure 1 displays interface state events as they are perceived by routing protocols.

- [Suppress Threshold, page 3](#)
- [Half-Life Period, page 3](#)
- [Reuse Threshold, page 3](#)
- [Maximum Suppress Time, page 3](#)

Suppress Threshold

The suppress threshold is the value of the accumulated penalty that triggers the router to dampen a flapping interface. The flapping interface is identified by the router and assigned a penalty for each up and down state change, but the interface is not automatically dampened. The router tracks the penalties that a flapping interface accumulates. When the accumulated penalty reaches the default or preconfigured suppress threshold, the interface is placed in a dampened state.

Half-Life Period

The half-life period determines how fast the accumulated penalty can decay exponentially. When an interface is placed in a dampened state, the router monitors the interface for additional up and down state changes. If the interface continues to accumulate penalties and the interface remains in the suppress threshold range, the interface will remain dampened. If the interface stabilizes and stops flapping, the penalty is reduced by half after each half-life period expires. The accumulated penalty will be reduced until the penalty drops to the reuse threshold. The configurable range of the half-life period timer is from 1 to 30 seconds. The default half-life period timer is 5 seconds.

Reuse Threshold

When the accumulated penalty decreases until the penalty drops to the reuse threshold, the route is unsuppressed and made available to other devices in the network. The range of the reuse value is from 1 to 20000 penalties. The default value is 1000 penalties.

Maximum Suppress Time

The maximum suppress time represents the maximum time an interface can remain dampened when a penalty is assigned to an interface. The maximum suppress time can be configured from 1 to 20000 seconds. The default maximum penalty timer is 20 seconds or four times the default half-life period (5 seconds). The maximum value of the accumulated penalty is calculated based on the maximum suppress time, reuse threshold, and half-life period.

Figure 1 *Interface State Change Events Perceived by the Routing Protocols*

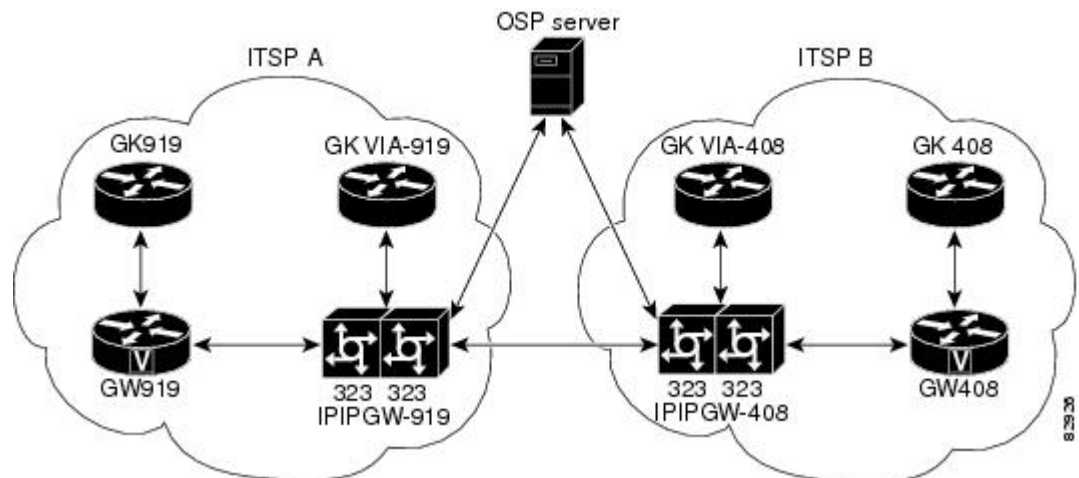

Affected Components

When an interface is not configured with dampening, or when an interface is configured with dampening but is not suppressed, the routing protocol behavior as a result of interface state transitions is not changed by the IP Event Dampening feature. However, if an interface is suppressed, the routing protocols and routing tables are immune to any further state transitions of the interface until it is unsuppressed.

- [Route Types, page 4](#)
- [Supported Protocols, page 4](#)

Route Types

The following interfaces are affected by the configuration of this feature:

- Connected routes:
 - The connected routes of dampened interfaces are not installed into the routing table.
 - When a dampened interface is unsuppressed, the connected routes will be installed into the routing table if the interface is up.
- Static routes:
 - Static routes assigned to a dampened interface are not installed into the routing table.
 - When a dampened interface is unsuppressed, the static route will be installed into the routing table if the interface is up.



Note

Only the primary interface can be configured with this feature, and all subinterfaces are subject to the same dampening configuration as the primary interface. IP Event Dampening does not track the flapping of individual subinterfaces on an interface.

Supported Protocols

The IP Event Dampening feature supports Border Gateway Protocol (BGP), Connectionless Network Services (CLNS), Enhanced Interior Gateway Routing Protocol (EIGRP), Intermediate System-to-Intermediate System (IS-IS), Hot Standby Routing Protocol (HSRP), Open Shortest Path First (OSPF), and Routing Information Protocol (RIP). The following list provides some general information about the operation of this feature with these protocols.

- BGP, EIGRP, IS-IS, RIP, and OSPF:
 - When an interface is dampened, the interface is considered to be down by the routing protocol. The routing protocol will not hold any adjacencies with this peer router over the dampened interface or generate advertisements of any routes related to this interface to other peer routers.
 - When the interface is unsuppressed and made available to the network, the interface will be considered by the routing protocols to be up. The routing protocols will be notified that the interface is in an up state and routing conditions will return to normal.
- HSRP:
 - When an interface is dampened, it is considered to be down by HSRP. HSRP will not generate HSRP messages out of the dampened interface or respond to any message received by the dampened interface. When the interface is unsuppressed and made available to the network, HSRP will be notified of the up state and will return to normal operations.

- CLNS:
 - When an interface is dampened, the interface is dampened to both IP and CLNS routing equally. The interface is dampened to both IP and CLNS because integrated routing protocols like IS-IS, IP, and CLNS routing are closely interconnected, so it is impossible to apply dampening separately.

**Note**

The IP Event Dampening feature has no effect on any routing protocols if it is not enabled or an interface is not dampened.

Network Deployments

In real network deployments, some routers may not be configured with interface dampening, and all routers may not even support this feature. No major routing issues are expected, even if the router at the other end of a point-to-point interface or routers of the same multicast LAN do not have interface dampening turned on or do not have this feature implemented. On the router, where the interface is dampened, routes associated with the interface will not be used. No packets will be sent out of this interface, and no routing protocol activity will be initiated with routers on the other side of the interface. However, routers on the other side can still install some routes, in their routing tables, that are associated with this subnet because the routers recognize that their own interfaces are up and can start forwarding packets to the dampened interface. In such situations, the router with the dampened interface will start forwarding these packets, depending on the routes in its routing table.

The IP Event Dampening feature does not introduce new information into the network. In fact, the effect of dampening is to subtract a subset of routing information from the network. Therefore, looping should not occur as a result of dampening.

Benefits of IP Event Dampening

Reduced Processing Load

The IP Event Dampening Feature employs a configurable exponential decay mechanism to suppress the effects of excessive interface flapping events on routing protocols. Excessive interface up and down state changes that are received in a short period of time are not processed and do not consume system resources. Other routers in the network need not waste system resources because of a flapping route.

Faster Convergence

The IP Event Dampening feature improves convergence times and stability throughout the network by isolating failures so that disturbances are not propagated. Routers that are not experiencing link flap reach convergence sooner, because routing tables are not rebuilt each time the offending router leaves and enters the service.

Improved Network Stability

The IP Event Dampening feature provides increased network stability. A router with a flapping interface removes the flapping interface from the network until the interface stabilizes, so other routers simply redirect traffic around the affected router until the interface becomes stable, which ensures that the router loses no data packets.

How to Configure IP Event Dampening

- [Enabling IP Event Dampening, page 6](#)
- [Verifying IP Event Dampening, page 7](#)

Enabling IP Event Dampening

The **dampening** command is entered in interface configuration mode to enable the IP Event Dampening feature. If this command is applied to an interface that already has dampening configured, all dampening states are reset and the accumulated penalty will be set to 0. If the interface has been dampened, the accumulated penalty will fall into the reuse threshold range, and the dampened interface will be made available to the network. The flap counts, however, are retained.

SUMMARY STEPS

1. **enable**
2. **configure terminal**
3. **interface** *type number*
4. **dampening** [*half-life-period reuse-threshold*] [*suppress-threshold max-suppress [restart-penalty]*]
5. **end**

DETAILED STEPS

	Command or Action	Purpose
Step 1	enable Example: Router> enable	Enables privileged EXEC mode. <ul style="list-style-type: none"> • Enter your password if prompted.
Step 2	configure terminal Example: Router# configure terminal	Enters global configuration mode.
Step 3	interface <i>type number</i> Example: Router(config)# interface Ethernet 0/0	Enters interface configuration mode and configures the specified interface.

Command or Action	Purpose
<p>Step 4 <code>dampening</code> [<i>half-life-period reuse-threshold</i>] [<i>suppress-threshold max-suppress</i>] [<i>restart-penalty</i>]</p> <p>Example:</p> <pre>Router(config-if)# dampening</pre>	<p>Enables interface dampening.</p> <ul style="list-style-type: none"> Entering the dampening command without any arguments enables interface dampening with default configuration parameters. When manually configuring the timer for the <i>restart-penalty</i> argument, the values must be manually entered for all arguments.
<p>Step 5 <code>end</code></p> <p>Example:</p> <pre>Router(config-if)# end</pre>	<p>Exits interface configuration mode and returns to privileged EXEC mode.</p>

Verifying IP Event Dampening

Use the **show dampening interface** or **show interface dampening** commands to verify the configuration of the IP Event Dampening feature.



Note

The **clear counters** command can be used to clear the flap count and reset it to zero. All other parameters and status, including dampening states and accumulated penalties, are not affected by this command.

SUMMARY STEPS

1. `enable`
2. `show dampening interface`
3. `show interface dampening`

DETAILED STEPS

Command or Action	Purpose
<p>Step 1 <code>enable</code></p> <p>Example:</p> <pre>Router> enable</pre>	<p>Enables privileged EXEC mode.</p> <ul style="list-style-type: none"> Enter your password if prompted.
<p>Step 2 <code>show dampening interface</code></p> <p>Example:</p> <pre>Router# show dampening interface</pre>	<p>Displays dampened interfaces.</p>

	Command or Action	Purpose
Step 3	show interface dampening Example: Router# show interface dampening	Displays dampened interfaces on the local router.

Configuration Examples for IP Event Dampening

- [Example: Enabling IP Event Dampening, page 8](#)
- [Example: Verifying IP Event Dampening, page 8](#)

Example: Enabling IP Event Dampening

The following example shows how to enable interface dampening on Ethernet interface 0/0 and sets the half life to 30 seconds, the reuse threshold to 1500, the suppress threshold to 10000, and the maximum suppress time to 120 seconds:

```
interface Ethernet 0/0
 dampening 30 1500 10000 120
```

The following example shows how to enable interface dampening on ATM interface 6/0 and uses the default interface dampening values:

```
interface atm 6/0
 dampening
```

The following example shows how to configure the router to apply a penalty of 500 on Ethernet interface 0/0 when the interface comes up for the first time after the router is reloaded:

```
interface Ethernet 0/0
 dampening 5 500 1000 20 500
```

Example: Verifying IP Event Dampening

The following sample output from the **show dampening interface** command displays a summary of interface dampening:

```
Router# show dampening interface
3 interfaces are configured with dampening.
No interface is being suppressed.
Features that are using interface dampening:
  IP Routing
  CLNS Routing
```

The following sample output from the **show interface dampening** command displays the summary of the dampening parameters and the status of the interfaces on the local router:

```
Router# show interface dampening
FastEthernet0/0
  Flaps Penalty      Supp ReuseTm   HalfL  ReuseV   SuppV  MaxSTm   MaxP Restart
```



```

0      0  FALSE      0      5  1000  2000  20  16000  0
ATM2/0
  Flaps Penalty  Supp ReuseTm  HalfL ReuseV  SuppV  MaxSTm  MaxP Restart
0      0  FALSE      0      5  1000  2000  20  16000  0
POS6/0
  Flaps Penalty  Supp ReuseTm  HalfL ReuseV  SuppV  MaxSTm  MaxP Restart
0      0  FALSE      0      5  1000  2000  20  16000  0

```

Additional References

Related Documents

Related Topic	Document Title
IP Routing Protocol-Independent commands: complete command syntax, command mode, command history, defaults, usage guidelines, and examples	Cisco IOS IP Routing: Protocol-Independent Command Reference
Cisco IOS commands	Cisco IOS Master Command List, All Releases

Standards

Standards	Title
No new or modified standards are supported by this feature, and support for existing standards has not been modified by this feature.	--

MIBs

MIBs	MIBs Link
No new or modified MIBs are supported by this feature, and support for existing MIBs has not been modified by this feature.	To locate and download MIBs for selected platforms, Cisco software releases, and feature sets, use Cisco MIB Locator found at the following URL: http://www.cisco.com/go/mibs

RFCs

RFCs	Title
No new or modified RFCs are supported by this feature, and support for existing standards has not been modified by this feature.	--

Technical Assistance

Description	Link
The Cisco Support and Documentation website provides online resources to download documentation, software, and tools. Use these resources to install and configure the software and to troubleshoot and resolve technical issues with Cisco products and technologies. Access to most tools on the Cisco Support and Documentation website requires a Cisco.com user ID and password.	http://www.cisco.com/cisco/web/support/index.html

Feature Information for IP Event Dampening

The following table provides release information about the feature or features described in this module. This table lists only the software release that introduced support for a given feature in a given software release train. Unless noted otherwise, subsequent releases of that software release train also support that feature.

Use Cisco Feature Navigator to find information about platform support and Cisco software image support. To access Cisco Feature Navigator, go to www.cisco.com/go/cfn. An account on Cisco.com is not required.

Table 1 *Feature Information for IP Event Dampening*

Feature Name	Releases	Feature Information
IP Event Dampening	12.0(22)S 12.2(14)S 12.2(13)T 12.2(18)SXD Cisco IOS XE 3.1.0SG	<p>The IP Event Dampening feature introduces a configurable exponential decay mechanism to suppress the effects of excessive interface flapping events on routing protocols and routing tables in the network. This feature allows the network operator to configure a router to automatically identify and selectively dampen a local interface that is flapping.</p> <p>The following commands were introduced or modified: dampening, debug dampening, show dampening interface, show interface dampening.</p>

Glossary

event dampening--The process in which a router dampens a flapping interface from the perspective of the routing tables and routing protocols of IP and CLNS by filtering the excessive route adjust message because of the interface state change.

flap--Rapid interface state changes from up to down and down to up within a short period of time.

half life--The rate of the exponential decay of the accumulated penalty is determined by this value.

maximum penalty--The maximum value beyond which the penalty assigned does not increase. It is derived from the maximum suppress time.

maximum suppress time--The maximum amount of time the interface can stay suppressed at the time a penalty is assigned.

penalty--A value assigned to an interface when it flaps. This value increases with each flap and decreases over time. The rate at which it decreases depends on the half life.

reuse threshold --The threshold value after which the interface will be unsuppressed and can be used again.

suppress threshold--Value of the accumulated penalty that triggers the router to dampen a flapping interface. When the accumulated penalty exceeds this value, the interface state is considered to be down from the perspective of the routing protocol.

suppressed--Suppressing an interface removes an interface from the network from the perspective of the routing protocol. An interface enters the suppressed state when it has flapped frequently enough for the penalty assigned to it to cross a threshold limit.

Cisco and the Cisco logo are trademarks or registered trademarks of Cisco and/or its affiliates in the U.S. and other countries. To view a list of Cisco trademarks, go to this URL: www.cisco.com/go/trademarks. Third-party trademarks mentioned are the property of their respective owners. The use of the word partner does not imply a partnership relationship between Cisco and any other company. (1110R)

Any Internet Protocol (IP) addresses and phone numbers used in this document are not intended to be actual addresses and phone numbers. Any examples, command display output, network topology diagrams, and other figures included in the document are shown for illustrative purposes only. Any use of actual IP addresses or phone numbers in illustrative content is unintentional and coincidental.

© 2011 Cisco Systems, Inc. All rights reserved.