



IEEE 802.1ad Support on Provider Bridges

First Published: April 19, 2010

Last Updated: May 26, 2011

Service provider bridges (also called provider bridges) allow devices in a service provider network to transparently carry the Layer 2 control frames of a customer. Spanning Tree Protocol (STP) bridge protocol data units (BPDUs) or Cisco Discovery Protocol frames are carried separately from the service provider traffic and from other customer traffic in the network of a service provider.

User network interface (UNI) ports of a provider bridge interface with customer devices have a specific set of requirements defined by the IEEE 802.1ad standard. These requirements enable provider bridges to have the same functionality as Layer 2 protocol tunneling and Q-in-Q (QnQ) bridges.

This document describes the IEEE 802.1ad implementation on Cisco devices using Layer 2 switch ports.

- [Finding Feature Information, page 1](#)
- [Restrictions for IEEE 802.1ad Support on Provider Bridges, page 2](#)
- [Information About IEEE 802.1ad Support on Provider Bridges, page 2](#)
- [How to Configure IEEE 802.1ad Support on Provider Bridges, page 8](#)
- [Configuration Examples for IEEE 802.1ad Support on Provider Bridges, page 10](#)
- [Additional References for IEEE 802.1ad Support on Provider Bridges, page 11](#)
- [Feature Information for IEEE 802.1ad Support on Provider Bridges, page 11](#)
- [Glossary, page 12](#)

Finding Feature Information

Your software release may not support all the features documented in this module. For the latest caveats and feature information, see [Bug Search Tool](#) and the release notes for your platform and software release. To find information about the features documented in this module, and to see a list of the releases in which each feature is supported, see the feature information table.

Use Cisco Feature Navigator to find information about platform support and Cisco software image support. To access Cisco Feature Navigator, go to www.cisco.com/go/cfn. An account on Cisco.com is not required.

Restrictions for IEEE 802.1ad Support on Provider Bridges

- The IEEE 802.1ad Support on Provider Bridges feature is not supported on the Cisco ME3400 series switch.
- In Cisco IOS Release 12.2(54)SE, the Cisco ME 3400E and Catalyst 3750 Metro switch platforms support this feature. The Cisco ME3400 switch platform does not support this feature.

Information About IEEE 802.1ad Support on Provider Bridges

Service Provider Bridges

Provider bridges pass the network traffic of multiple customers. The traffic flow of each customer must be isolated from one another. For Layer 2 protocols within customer domains to function properly, geographically separated customer sites must appear to be connected via a LAN and the provider network must be transparent.

The IEEE has reserved 33 Layer 2 MAC addresses for customer devices that operate Layer 2 protocols. If a provider bridge uses these standard MAC addresses for its Layer 2 protocols, the Layer 2 traffic of the customer devices and the service provider is mixed together. Provider bridges solve this traffic-mixing issue by providing Layer 2 protocol data unit (PDU) tunneling when a provider bridge (S-bridge) component and a provider edge bridge (C-bridge) component are used. The figure below shows the topology.

Figure 1: Layer 2 PDU Tunneling

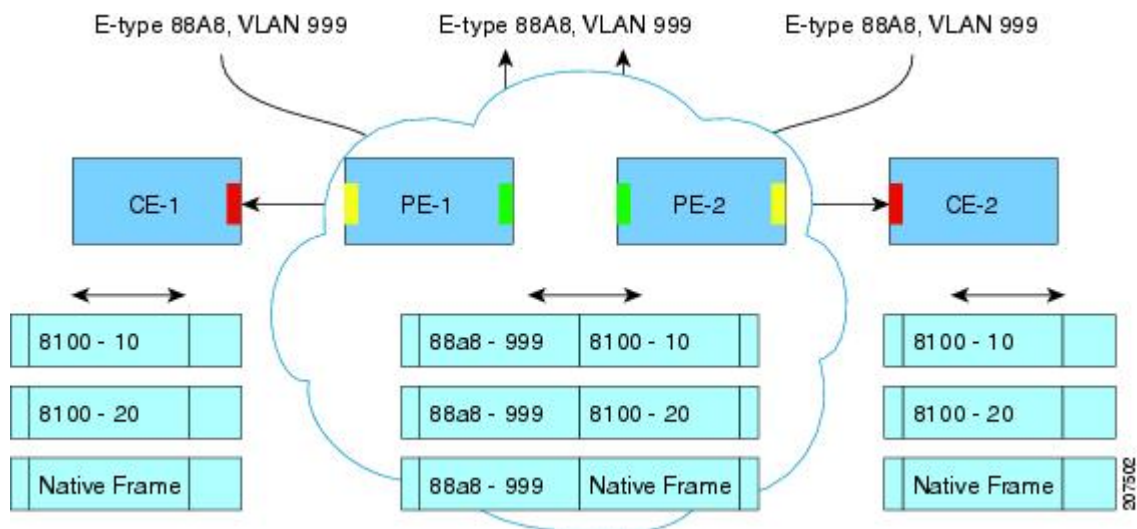

S-Bridge Component

The S-bridge component is capable of inserting or removing a service provider VLAN (S-VLAN) for all traffic on a particular port. IEEE 802.1ad adds a new tag called a Service tag (S-tag) to all ingress frames traveling from the customer to the service provider.

The VLAN in the S-tag is used for forwarding the traffic in the service provider network. Different customers use different S-VLANs, which results in isolation of traffic of each customer. In the S-tag, provider bridges do not understand the standard Ethertype. Hence, they use an Ethertype value that is different from the standard 802.1Q Ethertype value. This difference makes customer traffic that is tagged with the standard Ethertype appear as untagged in the provider network. The customer traffic is tunneled in the port VLAN of the provider port. 802.1ad service provider user network interfaces (S-UNIs) and network-network interfaces (NNIs) implement the S-bridge component.

For example, a VLAN tag has a VLAN ID of 1, the C-tag Ethertype has a value of 8100 0001, the S-tag Ethertype has a value of 88A8 0001, and the class of service (CoS) has a value of zero.

C-tag S-tag

 0x8100 | Priority bits | CFI | C-VLAN-ID 0x88A8 | Priority bits | 0 | S-VLAN-ID

C-Bridge Component

All customer VLANs (C-VLANs) that enter a user network interface (UNI) port in an S-bridge component receive the same service (marked with the same S-VLAN). C-VLAN components are not supported, but a customer may want to tag a particular C-VLAN packet separately to differentiate between services. Provider bridges allow C-VLAN packet tagging with a provider edge bridge, called the C-bridge component of the provider bridge. C-bridge components are C-VLAN aware and can insert or remove a C-VLAN 802.1Q tag. The C-bridge UNI port is capable of identifying the customer 802.1Q tag and inserting or removing an S-tag on the packet on a per-service instance or C-VLAN basis. A C-VLAN tagged service instance allows service instance selection and identification by C-VLAN. The 801.1ad customer user network interfaces (C-UNIs) implement the C-component.

MAC Addresses for Layer 2 Protocols

Layer 2 protocol data units (PDUs) of customers that are received by a provider bridge are not forwarded. Hence, Layer 2 protocols running at customer sites do not know the complete network topology. By using different set of addresses for the Layer 2 protocols running on provider bridges, IEEE 802.1ad causes Layer 2 PDUs of the customers device that enter the provider bridge to appear as unknown multicast traffic and forwards it on customer ports (on the same service provider VLAN (S-VLAN)). Layer 2 protocols of customer device can then run transparently.

The table below shows Layer 2 MAC addresses that are reserved for the C-VLAN component.

Table 1: Reserved Layer 2 MAC Addresses for the C-VLAN Component

Assignment	Value
Bridge Group Address	01-80-C2-00-00-00
IEEE 802.3 Full Duplex PAUSE Operation	01-80-C2-00-00-01
IEEE 802.3 Slow_Protocols_Multicast_Address	01-80-C2-00-00-02
IEEE 802.1X PAE Address	01-80-C2-00-00-03

Assignment	Value
Provider Bridge Group Address	01-80-C2-00-00-08
Provider Bridge GVRP Address	01-80-C2-00-00-0D
IEEE 802.1AB Link Layer Discovery Protocol Multicast Address	01-80-C2-00-00-0E
Reserved for future standardization	01-80-C2-00-00-04 01-80-C2-00-00-05 01-80-C2-00-00-06 01-80-C2-00-00-07 01-80-C2-00-00-09 01-80-C2-00-00-0A 01-80-C2-00-00-0B 01-80-C2-00-00-0C 01-80-C2-00-00-0F

The table below shows Layer 2 MAC addresses that are reserved for the S-VLAN component. These addresses are a subset of the C-VLAN component addresses, and the C-bridge does not forward the bridge protocol data units (BPDUs) of a provider to a customer network.

Table 2: Reserved Layer 2 MAC Addresses for the S-VLAN Component

Assignment	Value
IEEE 802.3 Full Duplex PAUSE Operation	01-80-C2-00-00-01
IEEE 802.3 Slow_Protocols_Multicast_Address	01-80-C2-00-00-02
IEEE 802.1X PAE Address	01-80-C2-00-00-03
Provider Bridge Group Address	01-80-C2-00-00-08
Reserved for future standardization	01-80-C2-00-00-04 01-80-C2-00-00-05 01-80-C2-00-00-06 01-80-C2-00-00-07 01-80-C2-00-00-09 01-80-C2-00-00-0A

Overview of IEEE 802.1ad Support on Provider Bridges

The IEEE 802.1ad Support on Provider Bridges feature is implemented on switch ports and supports the following IEEE 802.1ad specified functions:

- Operation of individual provider bridges
- Configuration and management of individual provider bridges
- Management of spanning tree and VLAN topologies within a provider network

Layer 2 PDU Destination MAC Addresses for Customer-Facing C-Bridge UNI Ports

The table below shows the Layer 2 protocol data unit (PDU) destination MAC addresses for customer-facing C-bridge user network interface (UNI) ports and how the frames are processed.

Table 3: Layer 2 PDU Destination MAC Addresses for Customer-Facing C-Bridge UNI Ports

MAC Address	Protocol	Significance on the C-Bridge UNI Port	Default Action
01-80-C2-00-00-00	Bridge Group Address (end-to-end BPDUs)	Data, BPDU (based on the CLI configuration of the I2 protocol command)	BPDU
01-80-C2-00-00-01	802.3X Pause Protocol	BPDU	MAC address processes
01-80-C2-00-00-02	Slow protocol address: 802.3ad LACP, 802.3ah OAM, Cisco Discovery Protocol, DTP, PagP, UDLD, VTP	BPDU	BPDU
01-80-C2-00-00-03	802.1x	BPDU	BPDU
01-80-C2-00-00-04	Reserved for future media access method	Drop	Drop
01-80-C2-00-00-05	Reserved for future media access method	Drop	Drop
01-80-C2-00-00-06	Reserved for future bridge use	Drop	Drop
01-80-C2-00-00-07	Ethernet Local Management Interface	BPDU	BPDU
01-80-C2-00-00-08	Provider STP (BPDU)	Drop	Drop

MAC Address	Protocol	Significance on the C-Bridge UNI Port	Default Action
01-80-C2-00-00-09	Reserved for future bridge use	Drop	Drop
01-80-C2-00-00-0A	Reserved for future bridge use	Drop	Drop
01-80-C2-00-00-0B	Reserved for future S-bridge purposes	Drop	Drop
01-80-C2-00-00-0C	Reserved for future S-bridge purposes	Drop	Drop
01-80-C2-00-00-0D	Provider bridge GVRP address	Drop	Drop
01-80-C2-00-00-0E	802.1ab LLDP	Data, BPDU (based on the CLI configuration of the l2protocol command)	BPDU
01-80-C2-00-00-0F	Reserved for future C-bridge or Q-bridge use	Drop	Drop
01-80-C2-00-00-10	All bridges address	BPDU	Peer
01-80-C2-00-00-20	GMRP	Data	Data
01-80-C2-00-00-21	GVRP	Data	Data
01-80-C2-00-00-22-2F	Other GARP addresses	Data	Data
01-00-0C-CC-CC-CC	Cisco Discovery Protocol, DTP, PagP, UDLD, VTP (end-to-end)	Data, BPDU (based on the CLI configuration of the l2protocol command)	BPDU
01-00-0C-CC-CC-CD	PVST (end-to-end)	Data, BPDU (based on the CLI configuration of the l2protocol command)	BPDU

Layer 2 PDU Destination MAC Addresses for Customer-Facing S-Bridge UNI Ports

If a port is operating as a customer-facing S-bridge user network interface (UNI), the destination MAC addresses shown in the below table are used for defining the Layer 2 protocol protocol data unit (PDU) processing at the S-bridge UNI.

Table 4: Layer 2 PDU Destination MAC Addresses for Customer-Facing S-Bridge UNI Ports

MAC Address	Protocol	Significance on the S-Bridge UNI Port	Default Action
01-80-C2-00-00-00	Bridge Protocol Data Units (BPDUs)	Data, BPDU (based on the CLI configuration of the l2protocol command)	Data
01-80-C2-00-00-01	802.3X Pause Protocol	BPDU	MAC address processes
01-80-C2-00-00-02	Slow protocol address: 802.3ad LACP, 802.3ah OAM	BPDU	BPDU
01-80-C2-00-00-03	802.1x	BPDU	BPDU
01-80-C2-00-00-04	Reserved for future media access method	Drop	Drop
01-80-C2-00-00-05	Reserved for future media access method	Drop	Drop
01-80-C2-00-00-06	Reserved for future bridge use	Drop	Drop
01-80-C2-00-00-07	Ethernet Local Management Interface	BPDU	BPDU (drop on NNI)
01-80-C2-00-00-08	Provider STP (BPDU)	BPDU	BPDU
01-80-C2-00-00-09	Reserved for future bridge use	Drop	Drop
01-80-C2-00-00-0A	Reserved for future bridge use	Drop	Drop
01-80-C2-00-00-0B	Reserved for future S-bridge use	Data	Data
01-80-C2-00-00-0C	Reserved for future S-bridge use	Data	Data
01-80-C2-00-00-0D	Provider bridge Generic VLAN Registration Protocol (GVRP) address	Data	Data
01-80-C2-00-00-0E	802.1ab Link Layer Discovery Protocol (LLDP)	Data, BPDU (based on the CLI configuration of the l2protocol command)	Data

MAC Address	Protocol	Significance on the S-Bridge UNI Port	Default Action
01-80-C2-00-00-0F	Reserved for future C-bridge or Q-bridge use	Data	Data
01-80-C2-00-00-10	All bridges address	Data	Data
01-80-C2-00-00-20	GARP Multicast Registration Protocol (GMRP)	Data	Data
01-80-C2-00-00-21	Generic VLAN Registration Protocol (GVRP)	Data	Data
01-80-C2-00-00-22-2F	Other Generic Attribute Registration Protocol (GARP) addresses	Data	Data
01-00-0C-CC-CC-CC	Cisco Discovery Protocol, Dynamic Trunking Protocol (DTP), Port Aggregation Protocol (PagP), UniDirectional Link Detection (UDLD), and VLAN Trunk Protocol (VTP)	Data, BPDU (based on the CLI configuration of the l2protocol command)	Data
01-00-0C-CC-CC-CD	Per-VLAN Spanning Tree (PVST)	Data, BPDU (based on the CLI configuration of the l2protocol command)	Data

How to Configure IEEE 802.1ad Support on Provider Bridges

Configuring a Switch Port to Process 802.1ad BPDUs

In an 802.1ad network, the default behavior for Layer 2 protocol data units (PDUs) on an interface depends on the 802.1ad interface type. If the interface type is an S-bridge user network interface (UNI), all Layer 2 PDUs are tunneled. If the interface type is a C-bridge UNI, all Layer 2 PDUs are processed (peered).

PDU processing on the S-bridge UNI is the same as on an 802.1ad network-network interface (NNI). Both types of interfaces have the same scope of MAC addresses. Perform the tasks in this section to configure switch port-to-peer (process) BPDUs:

Configuring a Switch Port to Process BPDUs

SUMMARY STEPS

1. enable
2. configure terminal
3. interface *type number*
4. switchport mode {access | trunk}
5. ethernet dot1ad {nni | uni {c-port | s-port}}
6. l2protocol peer [*protocol*]
7. end

DETAILED STEPS

	Command or Action	Purpose
Step 1	enable Example: Device> enable	Enables privileged EXEC mode. <ul style="list-style-type: none"> • Enter your password if prompted.
Step 2	configure terminal Example: Device# configure terminal	Enters global configuration mode.
Step 3	interface <i>type number</i> Example: Device(config)# interface gigabitethernet 0/3	Configures the interface and enters interface configuration mode.
Step 4	switchport mode {access trunk} Example: Device(config-if)# switchport mode trunk	Sets the interface type.
Step 5	ethernet dot1ad {nni uni {c-port s-port}} Example: Device(config-if)# ethernet dot1ad uni c-port	Configures a dot1ad network-network interface (NNI) or user network interface (UNI) port.
Step 6	l2protocol peer [<i>protocol</i>] Example: Device(config-if)# l2protocol peer vtp	Processes or forwards Layer 2 bridge protocol data units (BPDUs). <ul style="list-style-type: none"> • In this example, only VLAN Trunk Protocol (VTP) BPDUs are processed.

	Command or Action	Purpose
Step 7	end Example: Device(config-if)# end	Returns to privileged EXEC mode.

Configuration Examples for IEEE 802.1ad Support on Provider Bridges

Example: Configuring an 802.1ad S-Bridge UNI

The following example shows how to configure GigabitEthernet interface 0/2 of a provider edge (PE) as an 802.1ad S-bridge user network interface (UNI). In this example, only Cisco Discovery Protocol protocol data units (PDUs) will be forwarded (tunneled). Cisco Discovery Protocol PDUs are forwarded between the PE and a customer device.

```
Device# configure terminal
Device(config)# interface GigabitEthernet 0/2
Device(config-if)# switchport access vlan 500
Device(config-if)# ethernet dot1ad uni s-port
Device(config-if)# l2protocol forward cdp
Device(config-if)# end
```

Example: Configuring an 802.1ad C-Bridge UNI

The following example shows how to configure interface GigabitEthernet 0/3 of a PE as an 802.1ad C-bridge user network interface (UNI). In this example, only Cisco Discovery Protocol protocol data units (PDUs) are processed.

```
Device# configure terminal
Device(config)# interface GigabitEthernet 0/3
Device(config-if)# switchport mode trunk
Device(config-if)# ethernet dot1ad uni c-port
Device(config-if)# l2protocol peer cdp
Device(config-if)# end
```

Additional References for IEEE 802.1ad Support on Provider Bridges

Related Documents

Related Topic	Document Title
Cisco IOS commands	Cisco IOS Master Command List, All Releases
Cisco IOS Carrier Ethernet commands	Cisco IOS Carrier Ethernet Command Reference

Standards and RFCs

Standard	Title
IEEE 802.1ad	<i>Provider Bridges</i>

Technical Assistance

Description	Link
The Cisco Support and Documentation website provides online resources to download documentation, software, and tools. Use these resources to install and configure the software and to troubleshoot and resolve technical issues with Cisco products and technologies. Access to most tools on the Cisco Support and Documentation website requires a Cisco.com user ID and password.	http://www.cisco.com/cisco/web/support/index.html

Feature Information for IEEE 802.1ad Support on Provider Bridges

The following table provides release information about the feature or features described in this module. This table lists only the software release that introduced support for a given feature in a given software release train. Unless noted otherwise, subsequent releases of that software release train also support that feature.

Use Cisco Feature Navigator to find information about platform support and Cisco software image support. To access Cisco Feature Navigator, go to [http://www.cisco.com/cisco/web/featurenavigator/index.html](#). An account on Cisco.com is not required.

Table 5: Feature Information for IEEE 802.1ad Support on Provider Bridges.

Feature Name	Releases	Feature Information
IEEE 802.1ad Support on Provider Bridges	Cisco IOS XE Release 3.6E	<p>The IEEE 802.1ad Support on Provider Bridges feature is the IEEE 802.1ad implementation on Cisco devices using Layer 2 switch ports.</p> <p>In Cisco IOS XE Release 3.6E, this feature is supported on Cisco Catalyst 3850 Series Switches.</p> <p>The following commands were introduced or modified: ethernet dot1ad, l2protocol, and show ethernet dot1ad.</p>

Glossary

- DTP**—Dynamic Trunking Protocol.
- GARP**—Generic Attribute Registration Protocol.
- GMRP**—GARP Multicast Registration Protocol.
- GVRP**—Generic VLAN Registration Protocol.
- LLDP**—Link Layer Discovery Protocol.
- OAM**—Operations, Administration, and Maintenance.
- PagP**—Port Aggregation Protocol.
- PVST**—Per-VLAN Spanning Tree.
- UDLD**—UniDirectional Link Detection.
- VTP**—VLAN Trunk Protocol.