



# ITU-T Y.1731 Performance Monitoring in a Service Provider Network

---

ITU-T Y.1731 performance monitoring provides standard-based Ethernet performance monitoring that encompasses the measurement of Ethernet frame delay, frame-delay variation, and throughput as outlined in the ITU-T Y.1731 specification and interpreted by the Metro Ethernet Forum (MEF). Service providers offer service level agreements (SLAs) that describe the level of performance customers can expect for services. This document describes the Ethernet performance management aspect of SLAs.

- [Finding Feature Information, on page 1](#)
- [Prerequisites for ITU-T Y.1731 Performance Monitoring in a Service Provider Network, on page 1](#)
- [Information About ITU-T Y.1731 Performance Monitoring in a Service Provider Network, on page 2](#)
- [How to Configure ITU-T Y.1731 Performance Monitoring in a Service Provider Network, on page 4](#)
- [Configuration Examples for Configuring ITU-T Y.1731 Performance Monitoring Functions, on page 4](#)
- [Additional References, on page 4](#)
- [Feature Information for ITU-T Y.1731 Performance Monitoring in a Service Provider Network, on page 5](#)

## Finding Feature Information

Your software release may not support all the features documented in this module. For the latest caveats and feature information, see [Bug Search Tool](#) and the release notes for your platform and software release. To find information about the features documented in this module, and to see a list of the releases in which each feature is supported, see the feature information table.

Use Cisco Feature Navigator to find information about platform support and Cisco software image support. To access Cisco Feature Navigator, go to [www.cisco.com/go/cfn](http://www.cisco.com/go/cfn). An account on Cisco.com is not required.

## Prerequisites for ITU-T Y.1731 Performance Monitoring in a Service Provider Network

- IEEE-compliant connectivity fault management (CFM) must be configured and enabled for Y.1731 performance monitoring to function.



**Note** Y1731 is supported over Port Channel interfaces.

# Information About ITU-T Y.1731 Performance Monitoring in a Service Provider Network

## Frame Delay and Frame-Delay Variation

The Frame Delay parameter can be used for on-demand OAM measurements of frame delay and frame-delay variation. When a maintenance end point (MEP) is enabled to generate frames with frame-delay measurement (ETH-DM) information, it periodically sends frames with ETH-DM information to its peer MEP in the same maintenance entity. Peer MEPs perform frame-delay and frame-delay variation measurements through this periodic exchange during the diagnostic interval.

An MEP requires the following specific configuration information to support ETH-DM:

- MEG level—MEG level at which the MEP exists
- Priority
- Drop eligibility—marked drop ineligible
- Transmission rate
- Total interval of ETH-DM
- MEF10 frame-delay variation algorithm

A MEP transmits frames with ETH-DM information using the TxTimeStampf information element. TxTimeStampf is the time stamp for when the ETH-DM frame was sent. A receiving MEP can compare the TxTimeStampf value with the RxTimef value, which is the time the ETH-DM frame was received, and calculate one-way delay using the formula  $frame\ delay = RxTimef - TxTimeStampf$ .

One-way frame-delay measurement (1DM) requires that clocks at both the transmitting MEP and the receiving MEPs are synchronized. Measuring frame-delay variation does not require clock synchronization and the variation can be measured using 1DM or a frame-delay measurement message (DMM) and a frame-delay measurement reply (DMR) frame combination.

If it is not practical to have clocks synchronized, only two-way frame-delay measurements can be made. In this case, the MEP transmits a frame containing ETH-DM request information and the TxTimeStampf element, and the receiving MEP responds with a frame containing ETH-DM reply information and the TxTimeStampf value copied from the ETH-DM request information.

Two-way frame delay is calculated as  $(RxTimeb - TxTimeStampf) - (TxTimeStampb - RxTimeStampf)$ , where RxTimeb is the time that the frame with ETH-DM reply information was received. Two-way frame delay and variation can be measured using only DMM and DMR frames.

To allow more precise two-way frame-delay measurement, the MEP replying to a frame with ETH-DM request information can also include two additional time stamps in the ETH-DM reply information:

- RxTimeStampf—Time stamp of the time at which the frame with ETH-DM request information was received.
- TxTimeStampb—Time stamp of the time at which the transmitting frame with ETH-DM reply information was sent.
- The timestamping happens at the hardware level for DMM operations.



**Note** The frame-loss, frame-delay, and frame-delay variation measurement processes are aborted when faults related to continuity and availability occur or when known network topology changes occur.

An MIP is transparent to the frames with ETH-DM information; therefore, an MIP does not require information to support the ETH-DM function.

The figure below shows a functional overview of a typical network in which Y.1731 performance monitoring is used.

**Figure 1: Y.1731 Performance Monitoring**

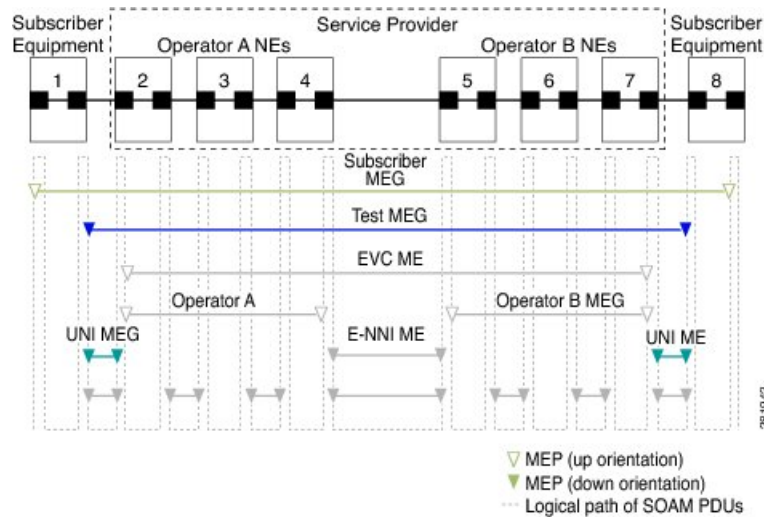

## Benefits of ITU-T Y.1731 Performance Monitoring

Combined with IEEE-compliant connectivity fault management (CFM), Y.1731 performance monitoring provides a comprehensive fault management and performance monitoring solution for service providers. This comprehensive solution in turn lessens service providers' operating expenses, improves their service-level agreements (SLAs), and simplifies their operations.

# How to Configure ITU-T Y.1731 Performance Monitoring in a Service Provider Network

## Configuring Performance Monitoring Parameters

The following new commands were introduced that can be used to configure and display performance monitoring parameters: **debug ethernet cfm pm**, **monitor loss counters**, and **show ethernet cfm pm**.

For more information about CFM and Y.1731 performance monitoring commands, see the *Cisco IOS Carrier Ethernet Command Reference*. For more information about debug commands, see the *Cisco IOS Debug Command Reference*.

## Configuration Examples for Configuring ITU-T Y.1731 Performance Monitoring Functions

### Example: Configuring Performance Monitoring

For Y.1731 performance monitoring configuration examples, see [Configuring IP SLAs Metro-Ethernet 3.0 \(ITU-T Y.1731\) Operations](#). For information on Y.1731 On-Demand and Concurrent Operations see, [IPSLA Y1731 On-Demand and Concurrent Operations](#).

## Additional References

### Related Documents

Related Topic	Document Title
MAC-in-MAC commands: complete command syntax, command mode, command history, defaults, usage guidelines, and examples	<a href="#">Cisco IOS Carrier Ethernet Command Reference</a>
Cisco IOS commands: master list of commands with complete command syntax, command mode, command history, defaults, usage guidelines, and examples	<a href="#">Cisco IOS Master Commands List, All Releases</a>

### Standards

Standard	Title
IEEE 802.1ah	IEEE 802.1ah - Provider Backbone Bridges

**MIBs**

<b>MIB</b>	<b>MIBs Link</b>
None	To locate and download MIBs for selected platforms, Cisco software releases, and feature sets, use Cisco MIB Locator found at the following URL: <a href="http://www.cisco.com/go/mibs">http://www.cisco.com/go/mibs</a>

**RFCs**

<b>RFC</b>	<b>Title</b>
No new or modified RFCs are supported by this feature, and support for existing RFCs has not been modified by this feature.	--

**Technical Assistance**

<b>Description</b>	<b>Link</b>
The Cisco Support and Documentation website provides online resources to download documentation, software, and tools. Use these resources to install and configure the software and to troubleshoot and resolve technical issues with Cisco products and technologies. Access to most tools on the Cisco Support and Documentation website requires a Cisco.com user ID and password.	<a href="http://www.cisco.com/cisco/web/support/index.html">http://www.cisco.com/cisco/web/support/index.html</a>

## Feature Information for ITU-T Y.1731 Performance Monitoring in a Service Provider Network

The following table provides release information about the feature or features described in this module. This table lists only the software release that introduced support for a given feature in a given software release train. Unless noted otherwise, subsequent releases of that software release train also support that feature.

Use Cisco Feature Navigator to find information about platform support and Cisco software image support. To access Cisco Feature Navigator, go to [www.cisco.com/go/cfn](http://www.cisco.com/go/cfn). An account on Cisco.com is not required.

Table 1: Feature Information for ITU-T Y.1731 Performance Monitoring in a Service Provider Network

Feature Name	Releases	Feature Information
Y.1731 Performance Monitoring	Cisco IOS XE Release 3.5S	<p>The Y.1731 Performance Monitoring feature describes the Ethernet performance monitoring aspect of SLAs such as frame loss, frame delay, and frame-delay variation.</p> <p>In Cisco IOS XE Release 3.5S, support was added for the Cisco ASR 903 Router.</p> <p>In Cisco IOS XE Release 3.6S, support for port channels and cross connect functionality was provided.</p> <p>The following commands were introduced or modified: <b>debug ethernet cfm pm</b>, <b>ethernet cfm distribution enable</b>, <b>monitor loss counters</b>, <b>show ethernet cfm pm</b>.</p>