



# Configuring Cisco Subscriber Service Switch Policies

---

The Subscriber Service Switch provides the framework for the management and scalability of PPP sessions that are switched from one virtual PPP link to another. It gives Internet service providers (ISPs) the flexibility to determine which services to provide to subscribers, the number of subscribers, and how to define the services. The primary focus of the Subscriber Service Switch is to direct PPP from one point to another using a Layer 2 subscriber policy. The policy manages tunneling of PPP in a policy-based bridging fashion.

- [Finding Feature Information, on page 1](#)
- [Prerequisites for Configuring a Subscriber Service Switch Policy, on page 1](#)
- [Restrictions for Configuring a Subscriber Service Switch Policy, on page 2](#)
- [Information About the Subscriber Service Switch, on page 2](#)
- [How to Configure a Subscriber Service Switch Policy, on page 6](#)
- [Configuration Examples for Configuring a Subscriber Service Switch Policy, on page 11](#)
- [Where to Go Next, on page 26](#)
- [Additional References, on page 26](#)
- [Feature Information for Configuring a Subscriber Service Switch Policy, on page 27](#)

## Finding Feature Information

Your software release may not support all the features documented in this module. For the latest caveats and feature information, see [Bug Search Tool](#) and the release notes for your platform and software release. To find information about the features documented in this module, and to see a list of the releases in which each feature is supported, see the feature information table.

Use Cisco Feature Navigator to find information about platform support and Cisco software image support. To access Cisco Feature Navigator, go to [www.cisco.com/go/cfn](http://www.cisco.com/go/cfn). An account on Cisco.com is not required.

## Prerequisites for Configuring a Subscriber Service Switch Policy

- Before configuring a Subscriber Service Switch policy, you must understand the concepts presented in the "Understanding Broadband Access Aggregation" module.

- Before configuring a Subscriber Service Switch policy, you must perform the PPP over Ethernet (PPPoE) configuration procedures in the "Providing Protocol Support for Broadband Access Aggregation of PPPoE Sessions" module or perform the PPP over ATM (PPPoA) configuration procedures in the "Providing Protocol Support for Broadband Access Aggregation of PPP over ATM Sessions" module.

## Restrictions for Configuring a Subscriber Service Switch Policy

The Subscriber Service Switch provides the framework for the management and scalability of PPP sessions that are switched from one virtual PPP link to another. The Subscriber Server Switch provides the infrastructure for any protocol to plug into; however, the initial implementation provides switching PPP over Ethernet and PPP over ATM session to a Layer 2 Tunneling Protocol (L2TP) device such as an L2TP access concentrator (LAC) switch, and switching L2TP sessions to an L2TP tunnel switch only.

## Information About the Subscriber Service Switch

The Subscriber Service Switch was developed in response to a need by Internet service providers (ISPs) for increased scalability and extensibility for remote access service selection and Layer 2 subscriber policy management. This Layer 2 subscriber policy is needed to manage tunneling of PPP in a policy-based bridging fashion.

## Benefits of the Subscriber Service Switch

The Subscriber Service Switch provides the framework for the management and scalability of PPP sessions that are switched from one virtual PPP link to another. It gives Internet service providers (ISPs) the flexibility to determine which services to provide to subscribers, the number of subscribers, and how to define the services. In the past, remote access service selection was largely determined by the telephone number dialed or the PPP username and password entered during a PPP authentication cycle. However, broadband, cable, Virtual Private Network (VPN), and wireless access methods have created an environment where PPP sessions may be tunneled over a variety of protocols and media. The multitude of protocols, management domains, network infrastructure, and variety of services has created a complex environment for directing a subscriber to a given service or application. The problem is further complicated by the much greater density of total PPP sessions that can be transported over shared media versus traditional point-to-point links. The Subscriber Service Switch can provide a flexible and extensible decision point linking an incoming subscriber (typically a PPP session over some physical or virtual link) to another tunneled link or local termination for Layer 3 processing.

The Subscriber Service Switch is also scalable in situations where a subscriber's Layer 2 service is switched across virtual links. Examples include switching among PPPoA, PPPoE, L2TP, Layer 2 Forwarding Protocol (L2F), Point-to-Point Tunneling Protocol (PPTP), generic routing encapsulation (GRE), and General Packet Radio Service (GPRS) Tunneling Protocol (GTP wireless data standard).

The figure below shows how the Subscriber Service Switch provides its own centralized switching path that bypasses the virtual-access-based switching available earlier. In the figure below, the Subscriber Service Switch is switching data traffic from personal computers in a home and corporate office and from a wireless user.

Figure 1: Basic Subscriber Service Switch Operation

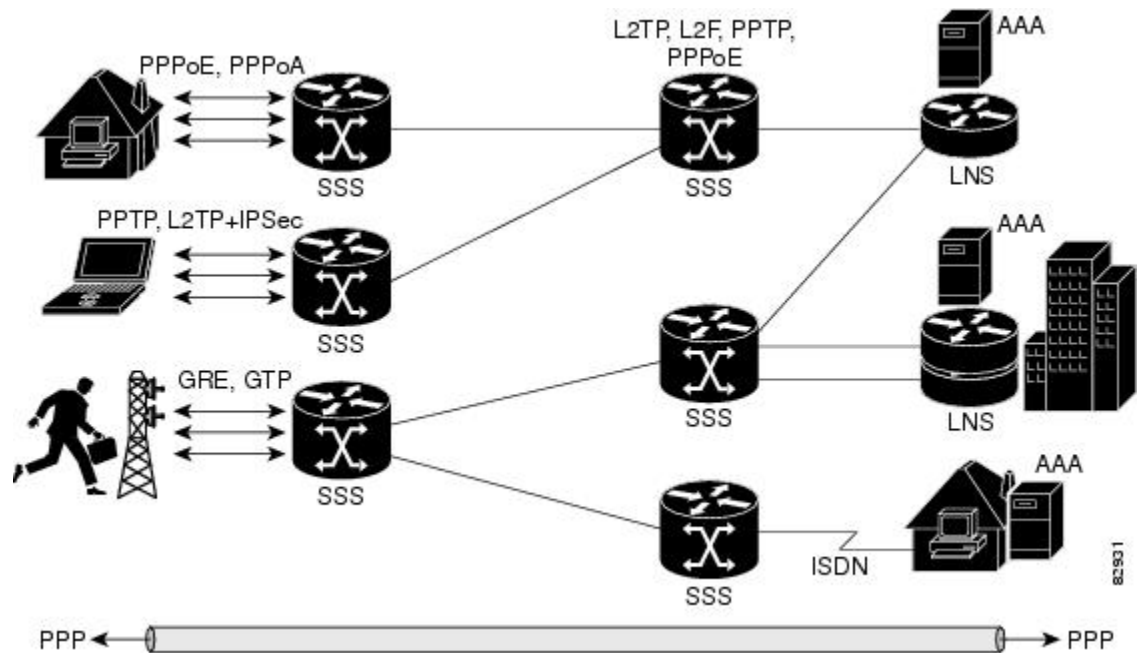

Protocols that register with the Subscriber Service Switch application programming interface (API) can take advantage of this switching path. Bypassing the virtual access interface in this manner helps the Cisco IOS XE software to scale to the increased number of sessions that the market demands. The Subscriber Service Switch also improves network performance. For example, benchmark testing indicates that performance of L2TP multihop tasks occurs twice as fast in networks with the Subscriber Service Switch as in networks without it.

## Backward Compatibility of Subscriber Service Switch Policies

All of the existing virtual private dialup network (VPDN), Multichassis Multilink PPP (MMLP), and local termination policies and configurations are maintained in the implementation of the Subscriber Service Switch; however, default policies may be overridden by the following configurations or events:

- Resource Manager (RM) VPDN authorization is attempted before VPDN authorization.
- VPDN authorization is attempted before Stack Group Forwarding (SGF) MMLP.
- VPDN service authorization is attempted only when the **vpdn enable** command is configured.
- RM VPDN service authorization is attempted only if RM is enabled.
- SGF authorization is attempted only when the **sgbp member** command is configured and one or both of the following service keys are available from the subscriber: unauthenticated PPP name and endpoint discriminator.
- The **dnis** and **domain** service keys, in that order, are used to authorize VPDN service, provided that VPDN service is enabled.
- An unauthenticated PPP name is always reduced to a domain name by taking all characters from the right of the PPP name up to a configurable delimiter character (default is the @ character). Only the domain portion is used to locate a service.

- If the **vpdn authen-before-forward** command is configured as a global configuration command, the authenticated PPP name is used to authorize VPDN service.
- The **vpdn-group** command can define four configurations:
  - Authorization for VPDN call termination (using the *accept-dialin* and **accept-dialout** keywords).
  - Authorization for VPDN subscriber service (using the **request-dialin** and **request-dialout** keywords).
  - A directive to collect further service keys and reauthorize (using the **authen-before-forward** keyword).
  - A tunnel configuration.

The Subscriber Service Switch adds a general configuration framework to replace the first three aspects of a VPDN group.

- If VPDN and SGF services either are not configured or cannot be authorized, local PPP termination service is selected. Further PPP authorization is still required to complete local termination.
- A two-phase authorization scheme is enabled by the **vpn domain authorization** command. An NAS-Port-ID (NAS port identifier) key is used to locate the first service record, which contains a restricted set of values for the domain substring of the unauthenticated PPP name. This filtered service key then locates the final service. Cisco refers to this scheme as domain preauthorization.
- Domain preauthorization will occur only when the **NAS-Port-ID** key is available.
- When domain preauthorization is enabled, both authenticated and unauthenticated domain names are checked for restrictions.
- It is possible to associate a fixed service with an ATM permanent virtual circuit (PVC), thus affecting any subscribers carried by the PVC. The **vpn service** command, in ATM VC or VC class configuration mode, and the associated key make up the generic service key.
- When the generic service key is available, it will be used for authorization instead of the unauthenticated domain name.
- If either the **vpdn authen-before-forward** or **per vpdn-group authen-before-forward** command is configured, the authenticated username is required and will be used to authorize VPDN service.
- To determine whether the **authen-before-forward** command is configured in a VPDN group (using the **vpdn-group** command), an unauthenticated username or the generic service key is required as the initial-want key set.
- When the global **vpdn authen-before-forward** command is not configured, the generic service key, if one is available, is used to determine whether the **authen-before-forward** function is configured in the VPDN group (using the **vpdn-group** command). If the generic service key is not available, the unauthenticated username will be used.
- If an accounting-enabled key is available, the unauthenticated username is required.
- VPDN multihop is allowed only when VPDN multihop is enabled.
- SGF on the L2TP network server (LNS) is allowed only when VPDN multihop is enabled on the LNS.
- Forwarding of SGF calls on the LAC is allowed only if VPDN multihop is enabled on the LAC.
- SGF-to-SGF multihop is not allowed.

- When PPP forwarding is configured, both Multilink PPP (MLP) and non-MLP calls are forwarded to the winner of the Stack Group Bidding Protocol (SGBP) bid.
- Authentication is always required for forwarded Packet Data Serving Node (PDSN) calls.
- When the **directed-request** function is enabled and activated using the **ip host** command, VPDN service authorization occurs only when the **vpdn authorize directed-request** command is used.
- Fixed legacy policy is still maintained for RM.

## Debug Commands Available for Subscriber Service Switch

The Subscriber Service Switch feature introduces five new EXEC mode **debug** commands to enable diagnostic output about Subscriber Service Switch call operation, as follows:

- **debug sss aaa authorization event** --Displays messages about AAA authorization events that are part of normal call establishment.
- **debug sss aaa authorization fsm** --Displays messages about AAA authorization state changes.
- **debug sss error** --Displays diagnostic information about errors that may occur during Subscriber Service Switch call setup.
- **debug sss event** --Displays diagnostic information about Subscriber Service Switch call setup events.
- **debug sss fsm** --Displays diagnostic information about the Subscriber Service Switch call setup state.

The following EXEC mode debug commands already exist:

- **debug redundancy** - This command is available on platforms that support redundancy.
- **debug sss eolog** --Collects SSS performance event data.
- **debug sss feature** --Enables debug for SSS feature events
- **debug sss packet** --Enables packet level event and information debugging for the Subscriber Service Switch.
- **debug sss policy** --Enables debug for SSS policy module events.
- **debug sss service** --Enables debug for service manager event.

These commands were designed to be used with **debug** commands that exist for troubleshooting PPP and other Layer 2 call operations. The table below lists some of these **debug** commands.

**Table 1: Additional Debugging Commands for Troubleshooting the Subscriber Service Switch**

Command	Purpose
<b>debug ppp negotiation</b>	Allows you to check that a client is passing PPP negotiation information.
<b>debug pppoe errors</b>	Displays PPPoE error messages.
<b>debug pppoe events</b>	Displays protocol event information.
<b>debug vpdn call events</b>	Enables VPDN call event debugging.

Command	Purpose
<code>debug vpdn call fsm</code>	Enables VPDN call setup state debugging.
<code>debug vpdn elog</code>	Enables VPDN performance event data collection.
<code>debug vpdn events</code>	Displays PPTP tunnel event change information.
<code>debug vpdn l2x-data</code>	Enables L2F and L2TP event and data debugging.
<code>debug vpdn l2x-errors</code>	Displays L2F and L2TP protocol errors that prevent tunnel establishment or normal operation.
<code>debug vpdn l2x-events</code>	Displays L2F and L2TP events that are part of tunnel establishment or shutdown.
<code>debug vpdn l2x-packets</code>	Enables L2F and L2TP packet level debugging.
<code>debug vpdn errors</code>	Displays PPTP protocol error messages.
<code>debug vpdn message</code>	Enables VPDN inter processing message debugging.
<code>debug vpdn packet</code>	Enables VPDN packet level debugging.
<code>debug vpdn scalability</code>	Enables VPDN scalability debugging.
<code>debug vpdn sss errors</code>	Displays diagnostic information about errors that may occur during VPDN Subscriber Service Switch call setup.
<code>debug vpdn sss events</code>	Displays diagnostic information about VPDN Subscriber Service Switch call setup events.



**Note** The **debug** commands are intended only for troubleshooting purposes, because the volume of output generated by the software can result in severe performance degradation on the router.

## How to Configure a Subscriber Service Switch Policy

The Subscriber Service Switch architecture is transparent, and existing PPP, VPDN, PPPoE, PPPoA, and authentication, authorization, and accounting (AAA) call configurations will continue to work in this environment. You can, however, enable Subscriber Service Switch preauthorization and Subscriber Service Switch type authorization. You may also find it helpful to verify Subscriber Service Switch call operation.

### Enabling Domain Preauthorization on a NAS

Perform the following task to enable the NAS to perform domain authorization before tunneling.

#### SUMMARY STEPS

1. **enable**
2. **configure terminal**
3. `vpdn authorize domain`

4. `exit`
5. `Router# show running-config`

### DETAILED STEPS

	Command or Action	Purpose
Step 1	<b>enable</b> <b>Example:</b> <code>Router&gt; enable</code>	Enables privileged EXEC mode. <ul style="list-style-type: none"> <li>• Enter your password if prompted.</li> </ul>
Step 2	<b>configure terminal</b> <b>Example:</b> <code>Router# configure terminal</code>	Enters global configuration mode.
Step 3	<code>vpdn authorize domain</code> <b>Example:</b> <code>Router(config)# vpdn authorize domain</code>	Enables domain preauthorization on an Network Access Server (NAS).
Step 4	<b>exit</b> <b>Example:</b> <code>Router(config)# exit</code>	Exits global configuration mode.
Step 5	<code>Router# show running-config</code> <b>Example:</b> <code>show running-config</code>	Displays the configuration so you can check that you successfully enabled domain preauthorization.

### What to Do Next

Create a RADIUS user profile for domain preauthorization. See the next section for more information.

## Creating a RADIUS User Profile for Domain Preauthorization

The table below contains the attributes needed to enable domain preauthorization in a RADIUS user file. Refer to the Cisco IOS XE Security Configuration Guide for information about creating a RADIUS user profile.

Table 2: Attributes for the RADIUS User Profile for Domain Preauthorization

RADIUS Entry	Purpose
<b>nas-port:</b> <i>ip-address:slot/subslot/port/vpi.vci</i>	Configures the NAS port username for domain preauthorization. <ul style="list-style-type: none"> <li><i>ip-address</i> : --Management IP address of the node switch processor (NSP).</li> <li><i>slot / subslot / port</i> --Specifies the ATM interface.</li> <li><i>vpi . vci</i> --Virtual path identifier (VPI) and virtual channel identifier (VCI) values for the PVC.</li> </ul>
<b>Password= "cisco"</b>	Sets the fixed password.
<b>User-Service-Type = Outbound-User</b>	Configures the service type as outbound.
<b>Cisco-AVpair= "vpdn:vpn-domain-list=domain1, domain2,..."</b>	Specifies the domains accessible to the user. <ul style="list-style-type: none"> <li><i>domain</i> --Domain to configure as accessible to the user.</li> </ul>

## Enabling a Subscriber Service Switch Preauthorization

When Subscriber Service Switch preauthorization is enabled on an LAC, local configurations for session limit per VC and per VLAN are overwritten by the per-NAS-port session limit downloaded from the server. Perform this task to enable preauthorization.

### SUMMARY STEPS

1. **enable**
2. **configure terminal**
3. **subscriber access {pppoe | pppoa} pre-authorize nas-port-id[aaa-method-list]**
4. **show sss session [all]**
5. **exit**

### DETAILED STEPS

	Command or Action	Purpose
<b>Step 1</b>	<b>enable</b>  <b>Example:</b>  Router> enable	Enables privileged EXEC mode. <ul style="list-style-type: none"> <li>• Enter your password if prompted.</li> </ul>
<b>Step 2</b>	<b>configure terminal</b>  <b>Example:</b>  Router# configure terminal	Enters global configuration mode.
<b>Step 3</b>	<b>subscriber access {pppoe   pppoa} pre-authorize nas-port-id[aaa-method-list]</b>	Enables Subscriber Service Switch preauthorization.



	Command or Action	Purpose
	<p><b>Example:</b></p> <p><b>Example:</b></p> <pre>Router(config)# subscriber access pppoe pre-authorize nas-port-id mlist-llid</pre> <p><b>Example:</b></p>	<p><b>Note</b> The LACs maintain a current session number per NAS port. As a new session request comes in, the LAC makes a preauthorization request to AAA to get the session limit, and compares it with the number of sessions currently on that NAS port. This command ensures that session limit querying is only enabled for PPPoE-type calls, not for any other call types.</p>
<b>Step 4</b>	<p><b>show sss session [all]</b></p> <p><b>Example:</b></p> <pre>Router(config)# show sss session all</pre>	Displays the Subscriber Service Switch session status.
<b>Step 5</b>	<p><b>exit</b></p> <p><b>Example:</b></p> <pre>Router(config)# exit</pre>	(Optional) Exits global configuration mode.

## What to Do Next

Information about troubleshooting a network running the Subscriber Service Switch can be found in the next section.

## Troubleshooting the Subscriber Service Switch

Perform this task to troubleshoot the Subscriber Service Switch. Examples of normal and failure operations can be found in the [Troubleshooting the Subscriber Service Switch Examples, on page 14](#). Reports from **debug** commands should be sent to technical personnel at Cisco Systems for evaluation.

Perform the following task to troubleshoot a network running the Subscriber Service Switch.

### SUMMARY STEPS

1. **enable**
2. **configure terminal**
3. **no logging console**
4. Use Telnet to access a router port and repeat Steps 2 and 3.
5. **terminal monitor**
6. **exit**
7. **debug sss *command-option***
8. **configure terminal**
9. **no terminal monitor**
10. **exit**

## DETAILED STEPS

	Command or Action	Purpose
<b>Step 1</b>	<b>enable</b> <b>Example:</b>  Router> enable	Enables privileged EXEC mode.  • Enter your password if prompted.
<b>Step 2</b>	<b>configure terminal</b> <b>Example:</b>  Router# configure terminal	Enters global configuration mode.
<b>Step 3</b>	<b>no logging console</b> <b>Example:</b>  Router(config)# no logging console	Disables all logging to the console terminal.  • To reenble logging to the console, use the <b>logging console</b> command.
<b>Step 4</b>	Use Telnet to access a router port and repeat Steps 2 and 3.	Enters global configuration mode in a recursive Telnet session, which allows the output to be redirected away from the console port.
<b>Step 5</b>	<b>terminal monitor</b> <b>Example:</b>  Router(config)# terminal monitor	Enables logging output on the virtual terminal.
<b>Step 6</b>	<b>exit</b> <b>Example:</b>  Router(config)# exit	Exits to privileged EXEC mode.
<b>Step 7</b>	<b>debug sss <i>command-option</i></b> <b>Example:</b>  Router# debug sss error	Enables the <b>debug</b> command.  <b>Note</b> You can enter more than one <b>debug</b> command.
<b>Step 8</b>	<b>configure terminal</b> <b>Example:</b>  Router# configure terminal	Enters global configuration mode.
<b>Step 9</b>	<b>no terminal monitor</b> <b>Example:</b>  Router(config)# no terminal monitor	Disables logging on the virtual terminal.
<b>Step 10</b>	<b>exit</b> <b>Example:</b>	Exits to privileged EXEC mode.

	Command or Action	Purpose
	Router(config)# exit	

## Configuration Examples for Configuring a Subscriber Service Switch Policy

### LAC Domain Authorization Example

The following example shows the configuration necessary for the LAC to participate in domain preauthorization:

```

!
aaa new-model
aaa authorization network default local group radius
!
vpdn authorize domain
!
radius-server host 10.9.9.9 auth-port 1645 acct-port 1646
radius-server attribute nas-port format d
radius-server key MyKey
radius-server vsa send authentication
!

```

### Domain Preauthorization RADIUS User Profile Example

The following example shows a typical domain preauthorization RADIUS user profile:

```

user = nas-port:10.9.9.9:0/0/0/30.33
profile_id = 826
profile_cycle = 1
radius=Cisco {
check_items= {
2=cisco
}
reply_attributes= {
9,1="vpdn:vpn-domain-list=example1.com,example2.com"
6=5
}
}
}
}

```

### Subscriber Service Switch Preauthorization Example

The following partial example signals the Subscriber Service Switch to preauthorize the NAS-Port-ID string before authorizing the domain name. This policy applies only to all sessions with a PPPoE access type.

```

vpdn-group 3
accept dialin
protocol pppoe
virtual-template 1
!

```

```

! Signals Subscriber Service Switch to preauthorize the NAS-Port-ID string before
! authorizing the domain name.
subscriber access pppoe pre-authorize nas-port-id mlist-llid
!

```

## Verify Subscriber Service Switch Call Operation Example

The following example command output from the **show sss session all** command provides an extensive report of Subscriber Service Switch session activity. Each section shows the unique identifier for each session, which can be used to correlate that particular session with the session information retrieved from other **show** commands or **debug** command traces. See the following **show vpdn session** command output for an example of this unique ID correlation.

```

Router# show sss session all
Current SSS Information: Total sessions 9
SSS session handle is 40000013, state is connected, service is VPDN
Unique ID is 9
SIP subscriber access type(s) are PPPoE/PPP
Identifier is nobody3@example.com
Last Changed 00:02:49
Root SIP Handle is DF000010, PID is 49
AAA unique ID is 10
Current SIP options are Req Fwding/Req Fwde
SSS session handle is B0000017, state is connected, service is VPDN
Unique ID is 10
SIP subscriber access type(s) are PPPoE/PPP
Identifier is nobody3@example.com
Last Changed 00:02:05
Root SIP Handle is B9000015, PID is 49
AAA unique ID is 11
Current SIP options are Req Fwding/Req Fwded
SSS session handle is D6000019, state is connected, service is VPDN
Unique ID is 11
SIP subscriber access type(s) are PPPoE/PPP
Identifier is nobody3@example.com
Last Changed 00:02:13
Root SIP Handle is D0000016, PID is 49
AAA unique ID is 12
Current SIP options are Req Fwding/Req Fwded
SSS session handle is 8C000003, state is connected, service is VPDN
Unique ID is 3
SIP subscriber access type(s) are PPPoE/PPP
Identifier is user3@example.com
Last Changed 2d21h
Root SIP Handle is D3000002, PID is 49
AAA unique ID is 3
Current SIP options are Req Fwding/Req Fwded
SSS session handle is BE00000B, state is connected, service is Local Term
Unique ID is 6
SIP subscriber access type(s) are PPPoE/PPP
Identifier is user1
Last Changed 00:03:56
Root SIP Handle is A9000009, PID is 49
AAA unique ID is 7
Current SIP options are Req Fwding/Req Fwded
SSS session handle is DC00000D, state is connected, service is Local Term
Unique ID is 7
SIP subscriber access type(s) are PPPoE/PPP
Identifier is user2
Last Changed 00:03:57
Root SIP Handle is 2C00000A, PID is 49

```

```

AAA unique ID is 8
Current SIP options are Req Fwding/Req Fwded
SSS session handle is DB000011, state is connected, service is VPDN
Unique ID is 8
SIP subscriber access type(s) are PPPoE/PPP
Identifier is nobody3@example.com
Last Changed 00:02:58
Root SIP Handle is 1000000F, PID is 49
AAA unique ID is 9
Current SIP options are Req Fwding/Req Fwded
SSS session handle is 3F000007, state is connected, service is Local Term
Unique ID is 2
SIP subscriber access type(s) are PPP
Identifier is user1
Last Changed 00:05:30
Root SIP Handle is 8A000009, PID is 92
AAA unique ID is 1
Current SIP options are Req Fwding/Req Fwded
SSS session handle is 97000005, state is connected, service is VPDN
Unique ID is 4
SIP subscriber access type(s) are PPP
Identifier is nobody2@example.com
Last Changed 00:07:16
Root SIP Handle is 32000000, PID is 92
AAA unique ID is 5
Current SIP options are Req Fwding/Req Fwded

```

## Correlating the Unique ID in show vpdn session Command Output

The following partial sample output from the **show vpdn session** command provides extensive reports on call activity for all L2TP, L2F, and PPPoE sessions, and identifies the unique ID for each session.

```

Router# show vpdn session all
L2TP Session Information Total tunnels 1 sessions 4
Session id 5 is up, tunnel id 13695
Call serial number is 3355500002
Remote tunnel name is User03
  Internet address is 10.0.0.63
  Session state is established, time since change 00:03:53
    52 Packets sent, 52 received
    2080 Bytes sent, 1316 received
  Last clearing of "show vpdn" counters never
  Session MTU is 1464 bytes
  Session username is nobody3@example.com
  Interface
    Remote session id is 692, remote tunnel id 58582
  UDP checksums are disabled
  SSS switching enabled
  No FS cached header information available
  Sequencing is off
Unique ID is 8
Session id 6 is up, tunnel id 13695
Call serial number is 3355500003
Remote tunnel name is User03
  Internet address is 10.0.0.63
  Session state is established, time since change 00:04:22
    52 Packets sent, 52 received
    2080 Bytes sent, 1316 received
  Last clearing of "show vpdn" counters never
  Session MTU is 1464 bytes
  Session username is nobody3@example.com
  Interface

```

```

Remote session id is 693, remote tunnel id 58582
UDP checksums are disabled
SSS switching enabled
No FS cached header information available
Sequencing is off
Unique ID is 9

```

## Troubleshooting the Subscriber Service Switch Examples

This section provides the following debugging session examples for a network running the Subscriber Service Switch:

Reports from **debug** commands should be sent to technical personnel at Cisco Systems for evaluation.

### Troubleshooting the Subscriber Service Switch Operation Example

The following example shows the **debug** commands used and sample output for debugging Subscriber Service Switch operation:

```

Router# debug sss event
Router# debug sss error
Router# debug sss state
Router# debug sss aaa authorization event
Router# debug sss aaa authorization fsm
SSS:
  SSS events debugging is on
  SSS error debugging is on
  SSS fsm debugging is on
  SSS AAA authorization event debugging is on
  SSS AAA authorization FSM debugging is on
*Mar 4 21:33:18.248: SSS INFO: Element type is Access-Type, long value is 3
*Mar 4 21:33:18.248: SSS INFO: Element type is Switch-Id, long value is -1509949436
*Mar 4 21:33:18.248: SSS INFO: Element type is Nasport, ptr value is 6396882C
*Mar 4 21:33:18.248: SSS INFO: Element type is AAA-Id, long value is 7
*Mar 4 21:33:18.248: SSS INFO: Element type is AAA-ACCT_ENBL, long value is 1
*Mar 4 21:33:18.248: SSS INFO: Element type is AccIe-Hdl, ptr value is 78000006
*Mar 4 21:33:18.248: SSS MGR [uid:7]: Event service-request, state changed from
wait-for-req to wait-for-auth
*Mar 4 21:33:18.248: SSS MGR [uid:7]: Handling Policy Authorize (1 pending sessions)
*Mar 4 21:33:18.248: SSS PM [uid:7]: Need the following key: Unauth-User
*Mar 4 21:33:18.248: SSS PM [uid:7]: Received Service Request
*Mar 4 21:33:18.248: SSS PM [uid:7]: Event <need keys>, State: initial-req to
need-init-keys
*Mar 4 21:33:18.248: SSS PM [uid:7]: Policy reply - Need more keys
*Mar 4 21:33:18.248: SSS MGR [uid:7]: Got reply Need-More-Keys from PM
*Mar 4 21:33:18.248: SSS MGR [uid:7]: Event policy-or-mgr-more-keys, state changed from
wait-for-auth to wait-for-req
*Mar 4 21:33:18.248: SSS MGR [uid:7]: Handling More-Keys event
*Mar 4 21:33:20.256: SSS INFO: Element type is Unauth-User, string value is
nobody@example.com
*Mar 4 21:33:20.256: SSS INFO: Element type is AccIe-Hdl, ptr value is 78000006
*Mar 4 21:33:20.256: SSS INFO: Element type is AAA-Id, long value is 7
*Mar 4 21:33:20.256: SSS INFO: Element type is Access-Type, long value is 0
*Mar 4 21:33:20.256: SSS MGR [uid:7]: Event service-request, state changed from
wait-for-req to wait-for-auth
*Mar 4 21:33:20.256: SSS MGR [uid:7]: Handling Policy Authorize (1 pending sessions)
*Mar 4 21:33:20.256: SSS PM [uid:7]: Received More Initial Keys
*Mar 4 21:33:20.256: SSS PM [uid:7]: Event <rcvd keys>, State: need-init-keys to
check-auth-needed
*Mar 4 21:33:20.256: SSS PM [uid:7]: Handling Authorization Check

```

```

*Mar  4 21:33:20.256: SSS PM [uid:7]: Event <send auth>, State: check-auth-needed to
authorizing
*Mar  4 21:33:20.256: SSS PM [uid:7]: Handling AAA service Authorization
*Mar  4 21:33:20.256: SSS PM [uid:7]: Sending authorization request for 'example.com'
*Mar  4 21:33:20.256: SSS AAA AUTHOR [uid:7]:Event <make request>, state changed from idle
to authorizing
*Mar  4 21:33:20.256: SSS AAA AUTHOR [uid:7]:Authorizing key example.com
*Mar  4 21:33:20.260: SSS AAA AUTHOR [uid:7]:AAA request sent for key example.com
*Mar  4 21:33:20.260: SSS AAA AUTHOR [uid:7]:Received an AAA pass
*Mar  4 21:33:20.260: SSS AAA AUTHOR [uid:7]:Event <found service>, state changed from
authorizing to complete
*Mar  4 21:33:20.260: SSS AAA AUTHOR [uid:7]:Found service info for key example.com
*Mar  4 21:33:20.260: SSS AAA AUTHOR [uid:7]:Event <free request>, state changed from
complete to terminal
*Mar  4 21:33:20.260: SSS AAA AUTHOR [uid:7]:Free request
*Mar  4 21:33:20.264: SSS PM [uid:7]: Event <found>, State: authorizing to end
*Mar  4 21:33:20.264: SSS PM [uid:7]: Handling Service Direction
*Mar  4 21:33:20.264: SSS PM [uid:7]: Policy reply - Forwarding
*Mar  4 21:33:20.264: SSS MGR [uid:7]: Got reply Forwarding from PM
*Mar  4 21:33:20.264: SSS MGR [uid:7]: Event policy-start-service-fsp, state changed from
wait-for-auth to wait-for-service
*Mar  4 21:33:20.264: SSS MGR [uid:7]: Handling Connect-Forwarding-Service event
*Mar  4 21:33:20.272: SSS MGR [uid:7]: Event service-fsp-connected, state changed from
wait-for-service to connected
*Mar  4 21:33:20.272: SSS MGR [uid:7]: Handling Forwarding-Service-Connected event

```

## Troubleshooting the Subscriber Service Switch on the LAC--Normal Operation Example

The following example shows the **debug** commands used and sample output indicating normal operation of the Subscriber Service Switch on the LAC:

```

Router# debug sss event
Router# debug sss error
Router# debug sss aaa authorization event
Router# debug sss aaa authorization fsm
Router# debug pppoe events
Router# debug pppoe errors
Router# debug ppp negotiation
Router# debug vpdn l2x-events
Router# debug vpdn l2x-errors
Router# debug vpdn sss events
Router# debug vpdn sss errors
Router# debug vpdn call events
Router# debug vpdn call fsm
Router# debug vpdn events
Router# debug vpdn errors
SSS:
  SSS events debugging is on
  SSS error debugging is on
  SSS AAA authorization event debugging is on
  SSS AAA authorization FSM debugging is on
PPPoE:
  PPPoE protocol events debugging is on
  PPPoE protocol errors debugging is on
PPP:
  PPP protocol negotiation debugging is on
VPN:
  L2X protocol events debugging is on
  L2X protocol errors debugging is on
  VPDN SSS events debugging is on
  VPDN SSS errors debugging is on

```

```

VPDN call event debugging is on
VPDN call FSM debugging is on
VPDN events debugging is on
VPDN errors debugging is on
*Nov 15 12:23:52.523: PPPoE 0: I PADI R:0000.0c14.71d0 L:ffff.ffff.ffff 1/32
ATM4/0.132
*Nov 15 12:23:52.523: PPPoE 0: O PADO R:0000.0c14.71d0 L:00b0.c2e9.c870 1/32
ATM4/0.132
*Nov 15 12:23:52.527: PPPoE 0: I PADR R:0000.0c14.71d0 L:00b0.c2e9.c870 1/32
ATM4/0.132
*Nov 15 12:23:52.527: PPPoE : encaps string prepared
*Nov 15 12:23:52.527: [13]PPPoE 10: Access IE handle allocated
*Nov 15 12:23:52.527: [13]PPPoE 10: pppoe SSS switch updated
*Nov 15 12:23:52.527: [13]PPPoE 10: Service request sent to SSS
*Nov 15 12:23:52.527: [13]PPPoE 10: Created R:00b0.c2e9.c870 L:0000.0c14.71d0 1/32
ATM4/0.132
*Nov 15 12:23:52.547: SSS INFO: Element type is Access-Type, long value is 3
*Nov 15 12:23:52.547: SSS INFO: Element type is Switch-Id, long value is 2130706444
*Nov 15 12:23:52.547: SSS INFO: Element type is Nasport, ptr value is 63C07288
*Nov 15 12:23:52.547: SSS INFO: Element type is AAA-Id, long value is 14
*Nov 15 12:23:52.547: SSS INFO: Element type is AccTe-Hdl, ptr value is B200000C
*Nov 15 12:23:52.547: SSS MGR [uid:13]: Handling Policy Authorize (1 pending
sessions)
*Nov 15 12:23:52.547: SSS PM [uid:13]: RM/VPDN disabled: RM/VPDN author not needed
*Nov 15 12:23:52.547: SSS PM [uid:13]: Received Service Request
*Nov 15 12:23:52.547: SSS PM [uid:13]: Handling Authorization Check
*Nov 15 12:23:52.547: SSS PM [uid:13]: Policy requires 'Unauth-User' key
*Nov 15 12:23:52.547: SSS PM [uid:13]: Policy reply - Need more keys
*Nov 15 12:23:52.547: SSS MGR [uid:13]: Got reply Need-More-Keys from PM
*Nov 15 12:23:52.547: SSS MGR [uid:13]: Handling More-Keys event
*Nov 15 12:23:52.547: [13]PPPoE 10: State REQ_NASPORT Event MORE_KEYS
*Nov 15 12:23:52.547: [13]PPPoE 10: O PADS R:0000.0c14.71d0 L:00b0.c2e9.c870 1/32
ATM4/0.132
*Nov 15 12:23:52.547: ppp13 PPP: Using default call direction
*Nov 15 12:23:52.547: ppp13 PPP: Treating connection as a dedicated line
*Nov 15 12:23:52.547: ppp13 PPP: Phase is ESTABLISHING, Active Open
*Nov 15 12:23:52.547: ppp13 LCP: O CONFREQ [Closed] id 1 len 19
*Nov 15 12:23:52.547: ppp13 LCP: MRU 1492 (0x010405D4)
*Nov 15 12:23:52.547: ppp13 LCP: AuthProto CHAP (0x0305C22305)
*Nov 15 12:23:52.547: ppp13 LCP: MagicNumber 0xB0EC4557 (0x0506B0EC4557)
*Nov 15 12:23:52.547: [13]PPPoE 10: State START_PPP Event DYN_BIND
*Nov 15 12:23:52.547: [13]PPPoE 10: data path set to PPP
*Nov 15 12:23:52.571: ppp13 LCP: I CONFREQ [REQsent] id 1 len 14
*Nov 15 12:23:52.571: ppp13 LCP: MRU 1492 (0x010405D4)
*Nov 15 12:23:52.571: ppp13 LCP: MagicNumber 0x0017455D (0x05060017455D)
*Nov 15 12:23:52.571: ppp13 LCP: O CONFACK [REQsent] id 1 len 14
*Nov 15 12:23:52.571: ppp13 LCP: MRU 1492 (0x010405D4)
*Nov 15 12:23:52.571: ppp13 LCP: MagicNumber 0x0017455D (0x05060017455D)
*Nov 15 12:23:54.543: ppp13 LCP: TIMEOUT: State ACKsent
*Nov 15 12:23:54.543: ppp13 LCP: O CONFREQ [ACKsent] id 2 len 19
*Nov 15 12:23:54.543: ppp13 LCP: MRU 1492 (0x010405D4)
*Nov 15 12:23:54.543: ppp13 LCP: AuthProto CHAP (0x0305C22305)
*Nov 15 12:23:54.543: ppp13 LCP: MagicNumber 0xB0EC4557 (0x0506B0EC4557)
*Nov 15 12:23:54.543: ppp13 LCP: I CONFACK [ACKsent] id 2 len 19
*Nov 15 12:23:54.543: ppp13 LCP: MRU 1492 (0x010405D4)
*Nov 15 12:23:54.543: ppp13 LCP: AuthProto CHAP (0x0305C22305)
*Nov 15 12:23:54.543: ppp13 LCP: MagicNumber 0xB0EC4557 (0x0506B0EC4557)
*Nov 15 12:23:54.543: ppp13 LCP: State is Open
*Nov 15 12:23:54.543: ppp13 PPP: Phase is AUTHENTICATING, by this end
*Nov 15 12:23:54.543: ppp13 CHAP: O CHALLENGE id 1 len 25 from "7200"
*Nov 15 12:23:54.547: ppp13 CHAP: I RESPONSE id 1 len 38 from "nobody@example.com"
*Nov 15 12:23:54.547: ppp13 PPP: Phase is FORWARDING, Attempting Forward
*Nov 15 12:23:54.547: SSS INFO: Element type is Unauth-User, string value is
nobody@example.com

```



```
*Nov 15 12:23:54.547: SSS INFO: Element type is AccIe-Hdl, ptr value is B200000C
*Nov 15 12:23:54.547: SSS INFO: Element type is AAA-Id, long value is 14
*Nov 15 12:23:54.547: SSS INFO: Element type is Access-Type, long value is 0
*Nov 15 12:23:54.547: SSS MGR [uid:13]: Handling Policy Authorize (1 pending
sessions)
*Nov 15 12:23:54.547: SSS PM [uid:13]: Received More Keys
*Nov 15 12:23:54.547: SSS PM [uid:13]: Handling Authorization Check
*Nov 15 12:23:54.547: SSS PM [uid:13]: Handling AAA service Authorization
*Nov 15 12:23:54.547: SSS PM [uid:13]: Sending authorization request for 'example.com'
*Nov 15 12:23:54.547: SSS AAA AUTHOR [uid:13]:Event <make request>, state changed
from idle to authorizing
*Nov 15 12:23:54.547: SSS AAA AUTHOR [uid:13]:Authorizing key example.com
*Nov 15 12:23:54.547: SSS AAA AUTHOR [uid:13]:AAA request sent for key example.com
*Nov 15 12:23:54.551: SSS AAA AUTHOR [uid:13]:Received an AAA pass
*Nov 15 12:23:54.551: SSS AAA AUTHOR [uid:13]:Event <found service>, state changed
from authorizing to complete
*Nov 15 12:23:54.551: SSS AAA AUTHOR [uid:13]:Found service info for key example.com
*Nov 15 12:23:54.551: SSS AAA AUTHOR [uid:13]:Event <free request>, state changed
from complete to terminal
*Nov 15 12:23:54.551: SSS AAA AUTHOR [uid:13]:Free request
*Nov 15 12:23:54.551: SSS PM [uid:13]: Handling Service Direction
*Nov 15 12:23:54.551: SSS PM [uid:13]: Policy reply - Forwarding
*Nov 15 12:23:54.551: SSS MGR [uid:13]: Got reply Forwarding from PM
*Nov 15 12:23:54.551: SSS MGR [uid:13]: Handling Connect-Service event
*Nov 15 12:23:54.551: VPDN CALL [uid:13]: Event connect req, state changed from idle
to connecting
*Nov 15 12:23:54.551: VPDN CALL [uid:13]: Requesting connection
*Nov 15 12:23:54.551: VPDN CALL [uid:13]: Call request sent
*Nov 15 12:23:54.551: VPDN MGR [uid:13]: Event client connect, state changed from
idle to connecting
*Nov 15 12:23:54.551: VPDN MGR [uid:13]: Initiating compulsory connection to
192.168.8.2
*Nov 15 12:23:54.551: Tnl/Sn61510/7 L2TP: Session FS enabled
*Nov 15 12:23:54.551: Tnl/Sn61510/7 L2TP: Session state change from idle to
wait-for-tunnel
*Nov 15 12:23:54.551: uid:13 Tnl/Sn61510/7 L2TP: Create session
*Nov 15 12:23:54.551: uid:13 Tnl/Sn61510/7 L2TP: O ICRQ to rpl 9264/0
*Nov 15 12:23:54.551: [13]PPPoE 10: Access IE nas port called
*Nov 15 12:23:54.555: Tnl61510 L2TP: Control channel retransmit delay set to 1
seconds
*Nov 15 12:23:54.555: uid:13 Tnl/Sn61510/7 L2TP: Session state change from
wait-for-tunnel to wait-reply
*Nov 15 12:23:54.555: [13]PPPoE 10: State LCP_NEGO Event PPP_FWDING
*Nov 15 12:23:54.559: uid:13 Tnl/Sn61510/7 L2TP: O ICCN to rpl 9264/13586
*Nov 15 12:23:54.559: Tnl61510 L2TP: Control channel retransmit delay set to 1
seconds
*Nov 15 12:23:54.559: uid:13 Tnl/Sn61510/7 L2TP: Session state change from
wait-reply to established
*Nov 15 12:23:54.559: uid:13 Tnl/Sn61510/7 L2TP: VPDN session up
*Nov 15 12:23:54.559: VPDN MGR [uid:13]: Event peer connected, state changed from
connecting to connected
*Nov 15 12:23:54.559: VPDN MGR [uid:13]: Succeed to forward nobody@example.com
*Nov 15 12:23:54.559: VPDN MGR [uid:13]: accounting start sent
*Nov 15 12:23:54.559: VPDN CALL [uid:13]: Event connect ok, state changed from
connecting to connected
*Nov 15 12:23:54.559: VPDN CALL [uid:13]: Connection succeeded
*Nov 15 12:23:54.559: SSS MGR [uid:13]: Handling Service-Connected event
*Nov 15 12:23:54.559: ppp13 PPP: Phase is FORWARDED, Session Forwarded
*Nov 15 12:23:54.559: [13]PPPoE 10: State LCP_NEGO Event PPP_FWDED
*Nov 15 12:23:54.563: [13]PPPoE 10: data path set to SSS Switch
*Nov 15 12:23:54.563: [13]PPPoE 10: Connected Forwarded
```

## Troubleshooting the Subscriber Service Switch on the LAC--Authorization Failure Example

The following is sample output indicating call failure due to authorization failure:

```
*Nov 15 12:37:24.535: PPPoE 0: I PADI R:0000.0c14.71d0 L:ffff.ffff.ffff 1/32
ATM4/0.132
*Nov 15 12:37:24.535: PPPoE 0: O PADO R:0000.0c14.71d0 L:00b0.c2e9.c870 1/32
ATM4/0.132
*Nov 15 12:37:24.539: PPPoE 0: I PADR R:0000.0c14.71d0 L:00b0.c2e9.c870 1/32
ATM4/0.132
*Nov 15 12:37:24.539: PPPoE : encaps string prepared
*Nov 15 12:37:24.539: [18]PPPoE 15: Access IE handle allocated
*Nov 15 12:37:24.539: [18]PPPoE 15: pppoe SSS switch updated
*Nov 15 12:37:24.539: PPPoE 15: AAA pppoe_aaa_acct_get_retrieved_attrs
*Nov 15 12:37:24.539: [18]PPPoE 15: AAA pppoe_aaa_acct_get_nas_port_details
*Nov 15 12:37:24.539: [18]PPPoE 15: AAA pppoe_aaa_acct_get_dynamic_attrs
*Nov 15 12:37:24.539: [18]PPPoE 15: AAA pppoe_aaa_acct_get_dynamic_attrs
*Nov 15 12:37:24.539: [18]PPPoE 15: AAA unique ID allocated
*Nov 15 12:37:24.539: [18]PPPoE 15: No AAA accounting method list
*Nov 15 12:37:24.539: [18]PPPoE 15: Service request sent to SSS
*Nov 15 12:37:24.539: [18]PPPoE 15: Created R:00b0.c2e9.c870 L:0000.0c14.71d0 1/32
ATM4/0.132
*Nov 15 12:37:24.559: SSS INFO: Element type is Access-Type, long value is 3
*Nov 15 12:37:24.559: SSS INFO: Element type is Switch-Id, long value is -738197487
*Nov 15 12:37:24.559: SSS INFO: Element type is Nasport, ptr value is 63C0E590
*Nov 15 12:37:24.559: SSS INFO: Element type is AAA-Id, long value is 19
*Nov 15 12:37:24.559: SSS INFO: Element type is AccIe-Hdl, ptr value is 5B000011
*Nov 15 12:37:24.559: SSS MGR [uid:18]: Handling Policy Authorize (1 pending
sessions)
*Nov 15 12:37:24.559: SSS PM [uid:18]: RM/VPDN disabled: RM/VPDN author not needed
*Nov 15 12:37:24.559: SSS PM [uid:18]: Received Service Request
*Nov 15 12:37:24.559: SSS PM [uid:18]: Handling Authorization Check
*Nov 15 12:37:24.559: SSS PM [uid:18]: Policy requires 'Unauth-User' key
*Nov 15 12:37:24.559: SSS PM [uid:18]: Policy reply - Need more keys
*Nov 15 12:37:24.559: SSS MGR [uid:18]: Got reply Need-More-Keys from PM
*Nov 15 12:37:24.559: SSS MGR [uid:18]: Handling More-Keys event
*Nov 15 12:37:24.559: [18]PPPoE 15: State REQ_NASPORT Event MORE_KEYS
*Nov 15 12:37:24.559: [18]PPPoE 15: O PADS R:0000.0c14.71d0 L:00b0.c2e9.c870 1/32
ATM4/0.132
*Nov 15 12:37:24.559: ppp18 PPP: Using default call direction
*Nov 15 12:37:24.559: ppp18 PPP: Treating connection as a dedicated line
*Nov 15 12:37:24.559: ppp18 PPP: Phase is ESTABLISHING, Active Open
*Nov 15 12:37:24.559: ppp18 LCP: O CONFREQ [Closed] id 1 len 19
*Nov 15 12:37:24.559: ppp18 LCP: MRU 1492 (0x010405D4)
*Nov 15 12:37:24.559: ppp18 LCP: AuthProto CHAP (0x0305C22305)
*Nov 15 12:37:24.559: ppp18 LCP: MagicNumber 0xB0F8A971 (0x0506B0F8A971)
*Nov 15 12:37:24.559: [18]PPPoE 15: State START_PPP Event DYN_BIND
*Nov 15 12:37:24.559: [18]PPPoE 15: data path set to PPP
*Nov 15 12:37:24.563: ppp18 LCP: I CONFREQ [REQsent] id 1 len 14
*Nov 15 12:37:24.563: ppp18 LCP: MRU 1492 (0x010405D4)
*Nov 15 12:37:24.563: ppp18 LCP: MagicNumber 0x0023A93E (0x05060023A93E)
*Nov 15 12:37:24.563: ppp18 LCP: O CONFACK [REQsent] id 1 len 14
*Nov 15 12:37:24.563: ppp18 LCP: MRU 1492 (0x010405D4)
*Nov 15 12:37:24.563: ppp18 LCP: MagicNumber 0x0023A93E (0x05060023A93E)
*Nov 15 12:37:26.523: ppp18 LCP: I CONFREQ [ACKsent] id 2 len 14
*Nov 15 12:37:26.523: ppp18 LCP: MRU 1492 (0x010405D4)
*Nov 15 12:37:26.523: ppp18 LCP: MagicNumber 0x0023A93E (0x05060023A93E)
*Nov 15 12:37:26.523: ppp18 LCP: O CONFACK [ACKsent] id 2 len 14
*Nov 15 12:37:26.527: ppp18 LCP: MRU 1492 (0x010405D4)
*Nov 15 12:37:26.527: ppp18 LCP: MagicNumber 0x0023A93E (0x05060023A93E)
*Nov 15 12:37:26.575: ppp18 LCP: TIMEOUT: State ACKsent
*Nov 15 12:37:26.575: ppp18 LCP: O CONFREQ [ACKsent] id 2 len 19
*Nov 15 12:37:26.575: ppp18 LCP: MRU 1492 (0x010405D4)
```

```

*Nov 15 12:37:26.575: ppp18 LCP: AuthProto CHAP (0x0305C22305)
*Nov 15 12:37:26.575: ppp18 LCP: MagicNumber 0xB0F8A971 (0x0506B0F8A971)
*Nov 15 12:37:26.575: ppp18 LCP: I CONFACK [ACKsent] id 2 len 19
*Nov 15 12:37:26.575: ppp18 LCP: MRU 1492 (0x010405D4)
*Nov 15 12:37:26.575: ppp18 LCP: AuthProto CHAP (0x0305C22305)
*Nov 15 12:37:26.575: ppp18 LCP: MagicNumber 0xB0F8A971 (0x0506B0F8A971)
*Nov 15 12:37:26.575: ppp18 LCP: State is Open
*Nov 15 12:37:26.575: ppp18 PPP: Phase is AUTHENTICATING, by this end
*Nov 15 12:37:26.575: ppp18 CHAP: O CHALLENGE id 1 len 25 from "7200"
*Nov 15 12:37:26.579: ppp18 CHAP: I RESPONSE id 1 len 38 from "nobody@example.com"
Nov 15 12:37:26.579: ppp18 PPP: Phase is FORWARDING, Attempting Forward
*Nov 15 12:37:26.579: SSS INFO: Element type is Unauth-User, string value is
nobody@example.com
*Nov 15 12:37:26.579: SSS INFO: Element type is AccIe-Hdl, ptr value is 5B000011
*Nov 15 12:37:26.579: SSS INFO: Element type is AAA-Id, long value is 19
Nov 15 12:37:26.579: SSS INFO: Element type is Access-Type, long value is 0
*Nov 15 12:37:26.579: SSS MGR [uid:18]: Handling Policy Authorize (1 pending
sessions)
*Nov 15 12:37:26.579: SSS PM [uid:18]: Received More Keys
*Nov 15 12:37:26.579: SSS PM [uid:18]: Handling Authorization Check
*Nov 15 12:37:26.579: SSS PM [uid:18]: Handling AAA service Authorization
*Nov 15 12:37:26.579: SSS PM [uid:18]: Sending authorization request for 'example.com'
*Nov 15 12:37:26.579: SSS AAA AUTHOR [uid:18]:Event <make request>, state changed
from idle to authorizing
*Nov 15 12:37:26.579: SSS AAA AUTHOR [uid:18]:Authorizing key example.com
*Nov 15 12:37:26.579: SSS AAA AUTHOR [uid:18]:AAA request sent for key example.com
*Nov 15 12:37:26.587: SSS AAA AUTHOR [uid:18]:Received an AAA failure
*Nov 15 12:37:26.587: SSS AAA AUTHOR [uid:18]:Event <service not found>, state
changed from authorizing to complete
*Nov 15 12:37:26.587: SSS AAA AUTHOR [uid:18]:No service authorization info found
*Nov 15 12:37:26.587: SSS AAA AUTHOR [uid:18]:Event <free request>, state changed
from complete to terminal
*Nov 15 12:37:26.587: SSS AAA AUTHOR [uid:18]:Free request
*Nov 15 12:37:26.587: SSS PM [uid:18]: Handling Next Authorization Check
*Nov 15 12:37:26.587: SSS PM [uid:18]: Default policy: SGF author not needed
*Nov 15 12:37:26.587: SSS PM [uid:18]: Handling Default Service
*Nov 15 12:37:26.587: SSS PM [uid:18]: Policy reply - Local terminate
*Nov 15 12:37:26.591: SSS MGR [uid:18]: Got reply Local-Term from PM
*Nov 15 12:37:26.591: SSS MGR [uid:18]: Handling Send-Client-Local-Term event
*Nov 15 12:37:26.591: ppp18 PPP: Phase is AUTHENTICATING, Unauthenticated User
Nov 15 12:37:26.595: ppp18 CHAP: O FAILURE id 1 len 25 msg is "Authentication
failed"
*Nov 15 12:37:26.599: ppp18 PPP: Sending Acct Event[Down] id[13]
*Nov 15 12:37:26.599: ppp18 PPP: Phase is TERMINATING
*Nov 15 12:37:26.599: ppp18 LCP: O TERMREQ [Open] id 3 len 4
*Nov 15 12:37:26.599: ppp18 LCP: State is Closed
*Nov 15 12:37:26.599: ppp18 PPP: Phase is DOWN
*Nov 15 12:37:26.599: ppp18 PPP: Phase is TERMINATING
*Nov 15 12:37:26.599: [18]PPPoE 15: State LCP_NEGO Event PPP_DISCNET
*Nov 15 12:37:26.599: [18]PPPoE 15: O PADT R:0000.0c14.71d0 L:00b0.c2e9.c870 1/32
ATM4/0.132
*Nov 15 12:37:26.599: [18]PPPoE 15: Destroying R:0000.0c14.71d0 L:00b0.c2e9.c870
1/32 ATM4/0.132
*Nov 15 12:37:26.599: [18]PPPoE 15: AAA account stopped
*Nov 15 12:37:26.599: SSS MGR [uid:18]: Processing a client disconnect
*Nov 15 12:37:26.599: SSS MGR [uid:18]: Handling Send-Service-Disconnect event

```

## Troubleshooting the Subscriber Service Switch on the LAC--Authentication Failure Example

The following is sample output indicating call failure due to authentication failure at the LNS:

```

*Nov 15 12:45:02.067: PPPoE 0: I PADI R:0000.0c14.71d0 L:ffff.ffff.ffff 1/32
ATM4/0.132

```

## Troubleshooting the Subscriber Service Switch on the LAC--Authentication Failure Example

```

*Nov 15 12:45:02.071: PPPoE 0: O PADO R:0000.0c14.71d0 L:00b0.c2e9.c870 1/32
ATM4/0.132
*Nov 15 12:45:02.071: PPPoE 0: I PADR R:0000.0c14.71d0 L:00b0.c2e9.c870 1/32
ATM4/0.132
*Nov 15 12:45:02.071: PPPoE : encap string prepared
*Nov 15 12:45:02.071: [21]PPPoE 18: Access IE handle allocated
*Nov 15 12:45:02.071: [21]PPPoE 18: pppoe SSS switch updated
*Nov 15 12:45:02.071: PPPoE 18: AAA pppoe_aaa_acct_get_retrieved_attrs
*Nov 15 12:45:02.071: [21]PPPoE 18: AAA pppoe_aaa_acct_get_nas_port_details
*Nov 15 12:45:02.071: [21]PPPoE 18: AAA pppoe_aaa_acct_get_dynamic_attrs
*Nov 15 12:45:02.071: [21]PPPoE 18: AAA pppoe_aaa_acct_get_dynamic_attrs
*Nov 15 12:45:02.071: [21]PPPoE 18: AAA unique ID allocated
*Nov 15 12:45:02.071: [21]PPPoE 18: No AAA accounting method list
*Nov 15 12:45:02.071: [21]PPPoE 18: Service request sent to SSS
*Nov 15 12:45:02.071: [21]PPPoE 18: Created R:00b0.c2e9.c870 L:0000.0c14.71d0 1/32
ATM4/0.132
*Nov 15 12:45:02.091: SSS INFO: Element type is Access-Type, long value is 3
*Nov 15 12:45:02.091: SSS INFO: Element type is Switch-Id, long value is 1946157076
*Nov 15 12:45:02.091: SSS INFO: Element type is Nasport, ptr value is 63B34170
*Nov 15 12:45:02.091: SSS INFO: Element type is AAA-Id, long value is 22
*Nov 15 12:45:02.091: SSS INFO: Element type is AccTe-Hdl, ptr value is 71000014
*Nov 15 12:45:02.091: SSS MGR [uid:21]: Handling Policy Authorize (1 pending
sessions)
*Nov 15 12:45:02.091: SSS PM [uid:21]: RM/VPDN disabled: RM/VPDN author not needed
*Nov 15 12:45:02.091: SSS PM [uid:21]: Received Service Request
*Nov 15 12:45:02.091: SSS PM [uid:21]: Handling Authorization Check
*Nov 15 12:45:02.091: SSS PM [uid:21]: Policy requires 'Unauth-User' key
*Nov 15 12:45:02.091: SSS PM [uid:21]: Policy reply - Need more keys
*Nov 15 12:45:02.091: SSS MGR [uid:21]: Got reply Need-More-Keys from PM
*Nov 15 12:45:02.091: SSS MGR [uid:21]: Handling More-Keys event
*Nov 15 12:45:02.091: [21]PPPoE 18: State REQ_NASPORT Event MORE_KEYS
*Nov 15 12:45:02.091: [21]PPPoE 18: O PADS R:0000.0c14.71d0 L:00b0.c2e9.c870 1/32
ATM4/0.132
*Nov 15 12:45:02.091: ppp21 PPP: Using default call direction
*Nov 15 12:45:02.091: ppp21 PPP: Treating connection as a dedicated line
*Nov 15 12:45:02.091: ppp21 PPP: Phase is ESTABLISHING, Active Open
*Nov 15 12:45:02.091: ppp21 LCP: O CONFREQ [Closed] id 1 len 19
*Nov 15 12:45:02.091: ppp21 LCP: MRU 1492 (0x010405D4)
*Nov 15 12:45:02.091: ppp21 LCP: AuthProto CHAP (0x0305C22305)
*Nov 15 12:45:02.091: ppp21 LCP: MagicNumber 0xB0FFA4D8 (0x0506B0FFA4D8)
*Nov 15 12:45:02.091: [21]PPPoE 18: State START_PPP Event DYN_BIND
*Nov 15 12:45:02.091: [21]PPPoE 18: data path set to PPP
*Nov 15 12:45:02.095: ppp21 LCP: I CONFREQ [REQsent] id 1 len 14
*Nov 15 12:45:02.095: ppp21 LCP: MRU 1492 (0x010405D4)
*Nov 15 12:45:02.095: ppp21 LCP: MagicNumber 0x002AA481 (0x0506002AA481)
*Nov 15 12:45:02.095: ppp21 LCP: O CONFACK [REQsent] id 1 len 14
*Nov 15 12:45:02.095: ppp21 LCP: MRU 1492 (0x010405D4)
*Nov 15 12:45:02.095: ppp21 LCP: MagicNumber 0x002AA481 (0x0506002AA481)
*Nov 15 12:45:02.315: Tn141436 L2TP: I StopCCN from rp1 tnl 31166
*Nov 15 12:45:02.315: Tn141436 L2TP: Shutdown tunnel
*Nov 15 12:45:02.315: Tn141436 L2TP: Tunnel state change from no-sessions-left to
idle
*Nov 15 12:45:04.055: ppp21 LCP: I CONFREQ [ACKsent] id 2 len 14
*Nov 15 12:45:04.055: ppp21 LCP: MRU 1492 (0x010405D4)
*Nov 15 12:45:04.059: ppp21 LCP: MagicNumber 0x002AA481 (0x0506002AA481)
*Nov 15 12:45:04.059: ppp21 LCP: O CONFACK [ACKsent] id 2 len 14
*Nov 15 12:45:04.059: ppp21 LCP: MRU 1492 (0x010405D4)
*Nov 15 12:45:04.059: ppp21 LCP: MagicNumber 0x002AA481 (0x0506002AA481)
*Nov 15 12:45:04.079: ppp21 LCP: TIMEOUT: State ACKsent
*Nov 15 12:45:04.079: ppp21 LCP: O CONFREQ [ACKsent] id 2 len 19
*Nov 15 12:45:04.079: ppp21 LCP: MRU 1492 (0x010405D4)
*Nov 15 12:45:04.079: ppp21 LCP: AuthProto CHAP (0x0305C22305)
*Nov 15 12:45:04.079: ppp21 LCP: MagicNumber 0xB0FFA4D8 (0x0506B0FFA4D8)
*Nov 15 12:45:04.079: ppp21 LCP: I CONFACK [ACKsent] id 2 len 19

```

```

*Nov 15 12:45:04.079: ppp21 LCP: MRU 1492 (0x010405D4)
*Nov 15 12:45:04.079: ppp21 LCP: AuthProto CHAP (0x0305C22305)
*Nov 15 12:45:04.079: ppp21 LCP: MagicNumber 0xB0FFFA4D8 (0x0506B0FFFA4D8)
*Nov 15 12:45:04.079: ppp21 LCP: State is Open
*Nov 15 12:45:04.079: ppp21 PPP: Phase is AUTHENTICATING, by this end
*Nov 15 12:45:04.079: ppp21 CHAP: O CHALLENGE id 1 len 25 from "7200"
*Nov 15 12:45:04.083: ppp21 CHAP: I RESPONSE id 1 len 38 from "nobody@example.com"
*Nov 15 12:45:04.083: ppp21 PPP: Phase is FORWARDING, Attempting Forward
*Nov 15 12:45:04.083: SSS INFO: Element type is Unauth-User, string value is
nobody@example.com
*Nov 15 12:45:04.083: SSS INFO: Element type is AccIe-Hdl, ptr value is 71000014
*Nov 15 12:45:04.083: SSS INFO: Element type is AAA-Id, long value is 22
*Nov 15 12:45:04.083: SSS INFO: Element type is Access-Type, long value is 0
*Nov 15 12:45:04.083: SSS MGR [uid:21]: Handling Policy Authorize (1 pending
sessions)
*Nov 15 12:45:04.083: SSS PM [uid:21]: Received More Keys
*Nov 15 12:45:04.083: SSS PM [uid:21]: Handling Authorization Check
*Nov 15 12:45:04.083: SSS PM [uid:21]: Handling AAA service Authorization
*Nov 15 12:45:04.083: SSS PM [uid:21]: Sending authorization request for 'example.com'
*Nov 15 12:45:04.083: SSS AAA AUTHOR [uid:21]:Event <make request>, state changed
from idle to authorizing
*Nov 15 12:45:04.083: SSS AAA AUTHOR [uid:21]:Authorizing key example.com
*Nov 15 12:45:04.083: SSS AAA AUTHOR [uid:21]:AAA request sent for key example.com
*Nov 15 12:45:04.095: SSS AAA AUTHOR [uid:21]:Received an AAA pass
*Nov 15 12:45:04.095: SSS AAA AUTHOR [uid:21]:Event <found service>, state changed
from authorizing to complete
*Nov 15 12:45:04.095: SSS AAA AUTHOR [uid:21]:Found service info for key example.com
*Nov 15 12:45:04.095: SSS AAA AUTHOR [uid:21]:Event <free request>, state changed
from complete to terminal
*Nov 15 12:45:04.095: SSS AAA AUTHOR [uid:21]:Free request
*Nov 15 12:45:04.095: SSS PM [uid:21]: Handling Service Direction
*Nov 15 12:45:04.095: SSS PM [uid:21]: Policy reply - Forwarding
*Nov 15 12:45:04.095: SSS MGR [uid:21]: Got reply Forwarding from PM
*Nov 15 12:45:04.099: SSS MGR [uid:21]: Handling Connect-Service event
*Nov 15 12:45:04.099: VPDN CALL [uid:21]: Event connect req, state changed from idle
to connecting
*Nov 15 12:45:04.099: VPDN CALL [uid:21]: Requesting connection
*Nov 15 12:45:04.099: VPDN CALL [uid:21]: Call request sent
*Nov 15 12:45:04.099: VPDN MGR [uid:21]: Event client connect, state changed from
idle to connecting
*Nov 15 12:45:04.099: VPDN MGR [uid:21]: Initiating compulsory connection to
192.168.8.2
*Nov 15 12:45:04.099: Tnl/Sn31399/10 L2TP: Session FS enabled
*Nov 15 12:45:04.099: Tnl/Sn31399/10 L2TP: Session state change from idle to
wait-for-tunnel
*Nov 15 12:45:04.099: uid:21 Tnl/Sn31399/10 L2TP: Create session
*Nov 15 12:45:04.099: Tnl31399 L2TP: SM State idle
*Nov 15 12:45:04.099: Tnl31399 L2TP: O SCCRQ
*Nov 15 12:45:04.099: Tnl31399 L2TP: Control channel retransmit delay set to 1
seconds
*Nov 15 12:45:04.099: Tnl31399 L2TP: Tunnel state change from idle to
wait-ctl-reply
*Nov 15 12:45:04.099: Tnl31399 L2TP: SM State wait-ctl-reply
*Nov 15 12:45:04.099: [21]PPPoE 18: State LCP_NEGO Event PPP_FWDING
*Nov 15 12:45:04.107: Tnl31399 L2TP: I SCCRQ from rp1
*Nov 15 12:45:04.107: Tnl31399 L2TP: Got a challenge from remote peer, rp1
*Nov 15 12:45:04.107: Tnl31399 L2TP: Got a response from remote peer, rp1
*Nov 15 12:45:04.107: Tnl31399 L2TP: Tunnel Authentication success
*Nov 15 12:45:04.107: Tnl31399 L2TP: Tunnel state change from wait-ctl-reply to
established
*Nov 15 12:45:04.107: Tnl31399 L2TP: O SCCCN to rp1 tnlid 9349
*Nov 15 12:45:04.107: Tnl31399 L2TP: Control channel retransmit delay set to 1
seconds
*Nov 15 12:45:04.107: Tnl31399 L2TP: SM State established

```

```

*Nov 15 12:45:04.107: uid:21 Tnl/Sn31399/10 L2TP: O ICRQ to rp1 9349/0
*Nov 15 12:45:04.107: [21]PPPoE 18: Access IE nas port called
*Nov 15 12:45:04.107: uid:21 Tnl/Sn31399/10 L2TP: Session state change from
wait-for-tunnel to wait-reply
*Nov 15 12:45:04.115: uid:21 Tnl/Sn31399/10 L2TP: O ICCN to rp1 9349/13589
*Nov 15 12:45:04.115: Tnl31399 L2TP: Control channel retransmit delay set to 1
seconds
*Nov 15 12:45:04.115: uid:21 Tnl/Sn31399/10 L2TP: Session state change from
wait-reply to established
*Nov 15 12:45:04.115: uid:21 Tnl/Sn31399/10 L2TP: VPDN session up
*Nov 15 12:45:04.115: VPDN MGR [uid:21]: Event peer connected, state changed from
connecting to connected
*Nov 15 12:45:04.115: VPDN MGR [uid:21]: Succeed to forward nobody@example.com
*Nov 15 12:45:04.115: VPDN MGR [uid:21]: accounting start sent
*Nov 15 12:45:04.115: [21]PPPoE 18: AAA pppoe_aaa_acct_get_dynamic_attrs
*Nov 15 12:45:04.115: [21]PPPoE 18: AAA pppoe_aaa_acct_get_dynamic_attrs
*Nov 15 12:45:04.115: VPDN CALL [uid:21]: Event connect ok, state changed from
connecting to connected
*Nov 15 12:45:04.115: VPDN CALL [uid:21]: Connection succeeded
*Nov 15 12:45:04.115: SSS MGR [uid:21]: Handling Service-Connected event
*Nov 15 12:45:04.115: ppp21 PPP: Phase is FORWARDED, Session Forwarded
*Nov 15 12:45:04.115: [21]PPPoE 18: State LCP_NEGO Event PPP_FWDED
*Nov 15 12:45:04.115: [21]PPPoE 18: data path set to SSS Switch
*Nov 15 12:45:04.119: [21]PPPoE 18: Connected Forwarded
*Nov 15 12:45:04.119: ppp21 PPP: Process pending packets
*Nov 15 12:45:04.139: uid:21 Tnl/Sn31399/10 L2TP: Result code(2): 2: Call
disconnected, refer to error msg
*Nov 15 12:45:04.139: Error code(6): Vendor specific
*Nov 15 12:45:04.139: Optional msg: Locally generated disconnect
*Nov 15 12:45:04.139: uid:21 Tnl/Sn31399/10 L2TP: I CDN from rp1 tnl 9349, cl
13589
01:06:21: %VPDN-6-CLOSED: L2TP LNS 192.168.8.2 closed user nobody@example.com; Result
2, Error 6, Locally generated disconnect
*Nov 15 12:45:04.139: uid:21 Tnl/Sn31399/10 L2TP: disconnect (L2X) IETF:
18/host-request Ascend: 66/VPDN Local PPP Disconnect
*Nov 15 12:45:04.139: uid:21 Tnl/Sn31399/10 L2TP: Destroying session
*Nov 15 12:45:04.139: uid:21 Tnl/Sn31399/10 L2TP: Session state change from
established to idle
*Nov 15 12:45:04.139: VPDN MGR [uid:21]: Event peer disconnect, state changed from
connected to disconnected
*Nov 15 12:45:04.139: VPDN MGR [uid:21]: Remote disconnected nobody@example.com
*Nov 15 12:45:04.139: VPDN MGR [uid:21]: accounting stop sent
*Nov 15 12:45:04.139: Tnl31399 L2TP: Tunnel state change from established to
no-sessions-left
*Nov 15 12:45:04.143: Tnl31399 L2TP: No more sessions in tunnel, shutdown (likely)
in 15 seconds
*Nov 15 12:45:04.143: VPDN CALL [uid:21]: Event server disc, state changed from
connected to disconnected
*Nov 15 12:45:04.143: VPDN CALL [uid:21]: Server disconnected call
*Nov 15 12:45:04.143: VPDN CALL [uid:21]: Event free req, state changed from
disconnected to terminal
*Nov 15 12:45:04.143: VPDN CALL [uid:21]: Free request
*Nov 15 12:45:04.143: SSS MGR [uid:21]: Handling Send Client Disconnect
*Nov 15 12:45:04.143: [21]PPPoE 18: State CNCT_FWDED Event SSS_DISCNCT
*Nov 15 12:45:04.143: ppp21 PPP: Sending Acct Event[Down] id[16]
*Nov 15 12:45:04.143: ppp21 PPP: Phase is TERMINATING
*Nov 15 12:45:04.143: ppp21 LCP: State is Closed
*Nov 15 12:45:04.143: ppp21 PPP: Phase is DOWN
*Nov 15 12:45:04.143: [21]PPPoE 18: O PADT R:0000.0c14.71d0 L:00b0.c2e9.c870 1/32
ATM4/0.132
*Nov 15 12:45:04.143: [21]PPPoE 18: Destroying R:0000.0c14.71d0 L:00b0.c2e9.c870
1/32 ATM4/0.132
*Nov 15 12:45:04.143: [21]PPPoE 18: AAA pppoe_aaa_acct_get_dynamic_attrs
*Nov 15 12:45:04.143: [21]PPPoE 18: AAA pppoe_aaa_acct_get_dynamic_attrs

```

```
*Nov 15 12:45:04.143: [21]PPPoE 18: AAA account stopped
*Nov 15 12:45:14.139: Tnl31399 L2TP: I StopCCN from rpl tnl 9349
*Nov 15 12:45:14.139: Tnl31399 L2TP: Shutdown tunnel
*Nov 15 12:45:14.139: Tnl31399 L2TP: Tunnel state change from no-sessions-left
```

## Troubleshooting the Subscriber Service Switch on the LNS--Normal Operation Example

The following example shows the **debug** commands used and sample output indicating normal operation of the Subscriber Service Switch on the LNS:

```
Router# debug sss event
Router# debug sss error
Router# debug sss fsm
Router# debug ppp negotiation
Router# debug vpdn l2x-events
Router# debug vpdn l2x-errors
Router# debug vpdn sss events
Router# debug vpdn sss errors
Router# debug vpdn sss fsm
SSS:
  SSS events debugging is on
  SSS error debugging is on
  SSS fsm debugging is on
PPP:
  PPP protocol negotiation debugging is on
VPN:
  L2X protocol events debugging is on
  L2X protocol errors debugging is on
  VPDN SSS events debugging is on
  VPDN SSS errors debugging is on
  VPDN SSS FSM debugging is on
3d17h: Tnl9264 L2TP: I ICRQ from server1 tnl 61510
3d17h: Tnl/Sn9264/13586 L2TP: Session FS enabled
3d17h: Tnl/Sn9264/13586 L2TP: Session state change from idle to wait-connect
3d17h: Tnl/Sn9264/13586 L2TP: New session created
3d17h: Tnl/Sn9264/13586 L2TP: O ICRP to server1 61510/7
3d17h: Tnl9264 L2TP: Control channel retransmit delay set to 1 seconds
3d17h: Tnl/Sn9264/13586 L2TP: I ICCN from server1 tnl 61510, cl 7
3d17h: nobody@example.com Tnl/Sn9264/13586 L2TP: Session state change from
wait-connect to wait-for-service-selection
3d17h: VPDN SSS []: Event start sss, state changed from IDLE to SSS
3d17h: VPDN SSS [uid:707]: Service request sent to SSS
3d17h: SSS INFO: Element type is Access-Type, long value is 4
3d17h: SSS INFO: Element type is Switch-Id, long value is 1493172561
3d17h: SSS INFO: Element type is Tunnel-Name, string value is server1
3d17h: SSS INFO: Element type is Can-SIP-Redirect, long value is 1
3d17h: SSS INFO: Element type is AAA-Id, long value is 16726
3d17h: SSS INFO: Element type is AccIe-Hdl, ptr value is D1000167
3d17h: SSS MGR [uid:707]: Event service-request, state changed from wait-for-req to
wait-for-auth
3d17h: SSS MGR [uid:707]: Handling Policy Authorize (1 pending sessions)
3d17h: SSS PM [uid:707]: RM/VPDN disabled: RM/VPDN author not needed
3d17h: SSS PM [uid:707]: Multihop disabled: AAA author not needed
3d17h: SSS PM [uid:707]: Multihop disabled: SGF author not needed
3d17h: SSS PM [uid:707]: No more authorization methods left to try, providing
default service
3d17h: SSS PM [uid:707]: Received Service Request
3d17h: SSS PM [uid:707]: Event <found>, State: initial-req to end
3d17h: SSS PM [uid:707]: Handling Service Direction
3d17h: SSS PM [uid:707]: Policy reply - Local terminate
3d17h: SSS MGR [uid:707]: Got reply Local-Term from PM
3d17h: SSS MGR [uid:707]: Event policy-connect local, state changed from
```

```

wait-for-auth to connected
3d17h: SSS MGR [uid:707]: Handling Send-Client-Local-Term event
3d17h: VPDN SSS [uid:707]: Event connect local, state changed from SSS to PPP
3d17h: ppp707 PPP: Phase is ESTABLISHING
3d17h: ppp707 LCP: I FORCED rcvd CONFACK len 15
3d17h: ppp707 LCP: MRU 1492 (0x010405D4)
3d17h: ppp707 LCP: AuthProto CHAP (0x0305C22305)
3d17h: ppp707 LCP: MagicNumber 0xB0EC4557 (0x0506B0EC4557)
3d17h: ppp707 LCP: I FORCED sent CONFACK len 10
3d17h: ppp707 LCP: MRU 1492 (0x010405D4)
3d17h: ppp707 LCP: MagicNumber 0x0017455D (0x05060017455D)
3d17h: ppp707 PPP: Phase is FORWARDING, Attempting Forward
3d17h: VPDN SSS [uid:707]: Event dyn bind resp, state changed from PPP to PPP
3d17h: ppp707 PPP: Phase is AUTHENTICATING, Unauthenticated User
3d17h: ppp707 PPP: Phase is FORWARDING, Attempting Forward
3d17h: VPDN SSS [uid:707]: Event connect local, state changed from PPP to PPP
3d17h: VPDN SSS [Vi4.2]: Event vaccess resp, state changed from PPP to PPP
3d17h: VPDN SSS [Vi4.2]: Event stat bind resp, state changed from PPP to CNCT
3d17h: Vi4.2 Tnl/Sn9264/13586 L2TP: Session state change from
wait-for-service-selection to established
3d17h: Vi4.2 PPP: Phase is AUTHENTICATING, Authenticated User
3d17h: Vi4.2 CHAP: O SUCCESS id 1 len 4
3d17h: Vi4.2 PPP: Phase is UP
3d17h: Vi4.2 IPCP: O CONFREQ [Closed] id 1 len 10
3d17h: Vi4.2 IPCP: Address 172.16.0.0 (0x030681010000)
3d17h: Vi4.2 PPP: Process pending packets
3d17h: Vi4.2 IPCP: I CONFREQ [REQsent] id 1 len 10
3d17h: Vi4.2 IPCP: Address 10.0.0.0 (0x030600000000)
3d17h: Vi4.2 AAA/AUTHOR/IPCP: Start. Her address 10.0.0.0, we want 10.0.0.0
3d17h: Vi4.2 AAA/AUTHOR/IPCP: Done. Her address 10.0.0.0, we want 10.0.0.0
3d17h: Vi4.2 IPCP: Pool returned 10.1.1.3
3d17h: Vi4.2 IPCP: O CONFNAK [REQsent] id 1 len 10
3d17h: Vi4.2 IPCP: Address 10.1.1.3 (0x03065B010103)
3d17h: Vi4.2 IPCP: I CONFACK [REQsent] id 1 len 10
3d17h: Vi4.2 IPCP: Address 172.16.0.0 (0x030681010000)
3d17h: Vi4.2 IPCP: I CONFREQ [ACKrcvd] id 2 len 10
3d17h: Vi4.2 IPCP: Address 10.1.1.3 (0x03065B010103)
3d17h: Vi4.2 IPCP: O CONFACK [ACKrcvd] id 2 len 10
3d17h: Vi4.2 IPCP: Address 10.1.1.3 (0x03065B010103)
3d17h: Vi4.2 IPCP: State is Open
3d17h: Vi4.2 IPCP: Install route to 10.1.1.3

```

## Troubleshooting the Subscriber Service Switch on the LNS--Tunnel Failure Example

The following is sample output indicating tunnel failure on the LNS:

```

3d17h: L2TP: I SCCRQ from server1 tnl 31399
3d17h: Tnl9349 L2TP: Got a challenge in SCCRQ, server1
3d17h: Tnl9349 L2TP: New tunnel created for remote server1, address 192.168.8.1
3d17h: Tnl9349 L2TP: O SCCRP to server1 tnlid 31399
3d17h: Tnl9349 L2TP: Control channel retransmit delay set to 1 seconds
3d17h: Tnl9349 L2TP: Tunnel state change from idle to wait-ctl-reply
3d17h: Tnl9349 L2TP: I SCCCN from server1 tnl 31399
3d17h: Tnl9349 L2TP: Got a Challenge Response in SCCCN from server1
3d17h: Tnl9349 L2TP: Tunnel Authentication success
3d17h: Tnl9349 L2TP: Tunnel state change from wait-ctl-reply to established
3d17h: Tnl9349 L2TP: SM State established
3d17h: Tnl9349 L2TP: I ICRQ from server1 tnl 31399
3d17h: Tnl/Sn9349/13589 L2TP: Session FS enabled
3d17h: Tnl/Sn9349/13589 L2TP: Session state change from idle to wait-connect
3d17h: Tnl/Sn9349/13589 L2TP: New session created
3d17h: Tnl/Sn9349/13589 L2TP: O ICRP to server1 31399/10
3d17h: Tnl9349 L2TP: Control channel retransmit delay set to 1 seconds

```



```
3d17h: Tnl/Sn9349/13589 L2TP: I ICCN from server1 tnl 31399, cl 10
3d17h: nobody@example.com Tnl/Sn9349/13589 L2TP: Session state change from
wait-connect to wait-for-service-selection
3d17h: VPDN SSS [:] Event start sss, state changed from IDLE to SSS
3d17h: VPDN SSS [uid:709]: Service request sent to SSS
3d17h: SSS INFO: Element type is Access-Type, long value is 4
3d17h: SSS INFO: Element type is Switch-Id, long value is -1912602284
3d17h: SSS INFO: Element type is Tunnel-Name, string value is server1
3d17h: SSS INFO: Element type is Can-SIP-Redirect, long value is 1
3d17h: SSS INFO: Element type is AAA-Id, long value is 16729
3d17h: SSS INFO: Element type is AccIe-Hdl, ptr value is 8D00016A
3d17h: SSS MGR [uid:709]: Event service-request, state changed from wait-for-req to
wait-for-auth
3d17h: SSS MGR [uid:709]: Handling Policy Authorize (1 pending sessions)
3d17h: SSS PM [uid:709]: RM/VPDN disabled: RM/VPDN author not needed
3d17h: SSS PM [uid:709]: Multihop disabled: AAA author not needed
3d17h: SSS PM [uid:709]: Multihop disabled: SGF author not needed
d17h: SSS PM [uid:709]: No more authorization methods left to try, providing default
service
3d17h: SSS PM [uid:709]: Received Service Request
3d17h: SSS PM [uid:709]: Event <found>, State: initial-req to end
3d17h: SSS PM [uid:709]: Handling Service Direction
3d17h: SSS PM [uid:709]: Policy reply - Local terminate
3d17h: SSS MGR [uid:709]: Got reply Local-Term from PM
3d17h: SSS MGR [uid:709]: Event policy-connect local, state changed from
wait-for-auth to connected
3d17h: SSS MGR [uid:709]: Handling Send-Client-Local-Term event
3d17h: VPDN SSS [uid:709]: Event connect local, state changed from SSS to PPP
3d17h: ppp709 PPP: Phase is ESTABLISHING
3d17h: ppp709 LCP: I FORCED rcvd CONFACK len 15
3d17h: ppp709 LCP: MRU 1492 (0x010405D4)
3d17h: ppp709 LCP: AuthProto CHAP (0x0305C22305)
3d17h: ppp709 LCP: MagicNumber 0xB0FFFA4D8 (0x0506B0FFFA4D8)
3d17h: ppp709 LCP: I FORCED sent CONFACK len 10
3d17h: ppp709 LCP: MRU 1492 (0x010405D4)
3d17h: ppp709 LCP: MagicNumber 0x002AA481 (0x0506002AA481)
3d17h: ppp709 PPP: Phase is FORWARDING, Attempting Forward
3d17h: VPDN SSS [uid:709]: Event dyn bind resp, state changed from PPP to PPP
3d17h: ppp709 PPP: Phase is AUTHENTICATING, Unauthenticated User
3d17h: ppp709 CHAP: O FAILURE id 1 len 25 msg is "Authentication failed"
3d17h: ppp709 PPP: Sending Acct Event[Down] id[4159]
3d17h: ppp709 PPP: Phase is TERMINATING
3d17h: ppp709 LCP: O TERMREQ [Open] id 1 len 4
3d17h: ppp709 LCP: State is Closed
3d17h: ppp709 PPP: Phase is DOWN
3d17h: ppp709 PPP: Phase is TERMINATING
3d17h: VPDN SSS [uid:709]: Event peer disc, state changed from PPP to DSC
3d17h: nobody@example.com Tnl/Sn9349/13589 L2TP: disconnect (AAA) IETF:
17/user-error Ascend: 26/PPP CHAP Fail
3d17h: nobody@example.com Tnl/Sn9349/13589 L2TP: O CDN to server1 31399/10
3d17h: Tnl9349 L2TP: Control channel retransmit delay set to 1 seconds
3d17h: nobody@example.com Tnl/Sn9349/13589 L2TP: Destroying session
3d17h: nobody@example.com Tnl/Sn9349/13589 L2TP: Session state change from
wait-for-service-selection to idle
3d17h: VPDN SSS [uid:709]: Event vpdn disc, state changed from DSC to END
3d17h: Tnl9349 L2TP: Tunnel state change from established to no-sessions-left
3d17h: Tnl9349 L2TP: No more sessions in tunnel, shutdown (likely) in 10 seconds
3d17h: SSS MGR [uid:709]: Processing a client disconnect
3d17h: SSS MGR [uid:709]: Event client-disconnect, state changed from connected to
end
3d17h: SSS MGR [uid:709]: Handling Send-Service-Disconnect event
3d17h: Tnl9349 L2TP: O StopCCN to server1 tnlid 31399
3d17h: Tnl9349 L2TP: Control channel retransmit delay set to 1 seconds
```

```
3d17h: Tn19349 L2TP: Tunnel state change from no-sessions-left to shutting-down
3d17h: Tn19349 L2TP: Shutdown tunnel
```

## Where to Go Next

- If you want to establish PPPoE session limits for sessions on a specific permanent virtual circuit or VLAN configured on an L2TP access concentrator, refer to the "Establishing PPPoE Session Limits per NAS Port" module.
- If you want to use service tags to enable a PPPoE server to offer PPPoE clients a selection of service during call setup, refer to the "Offering PPPoE Clients a Selection of Services During Call Setup" module.
- If you want to enable an L2TP access concentrator to relay active discovery and service selection functionality for PPPoE over a L2TP control channel to an LNS or tunnel switch, refer to the "Enabling PPPoE Relay Discovery and Service Selection Functionality" module.
- If you want to configure a transfer upstream of the PPPoX session speed value, refer to the "Configuring Upstream Connections Speed Transfer" module.
- If you want to use the Simple Network Management Protocol (SNMP) to monitor PPPoE sessions, refer to the "Monitoring PPPoE Sessions with SNMP" module.
- If you want to identify a physical subscribe line for RADIUS communication with a RADIUS server, refer to the "Identifying a Physical Subscriber Line for RADIUS Access and Accounting" module.
- If you want to configure a Cisco Subscriber Service Switch, see the "Configuring Cisco Subscriber Service Switch Policies" module.

## Additional References

The following sections provide references related to configuring Cisco Subscriber Service Switch policies.

### Related Documents

Related Topic	Document Title
Broadband access aggregation concepts	Understanding Broadband Access Aggregation module
Tasks for preparing for broadband access aggregation.	Preparing for Broadband Access Aggregation module
Broadband access commands: complete command syntax, command mode, command history, defaults, usage guidelines, and examples	<i>Cisco IOS Broadband Access Aggregation and DSL Command Reference</i>
Configuration procedure for PPPoE.	Providing Protocol Support for Broadband Access Aggregation of PPPoE Sessions
Configuration procedures for PPPoA.	Providing Protocol Support for Broadband Access Aggregation of PPP over ATM Sessions

**Standards**

Standards	Title
None	--

**MIBs**

MIBs	MIBs Link
None	To locate and download MIBs for selected platforms, Cisco IOS XE software releases, and feature sets, use Cisco MIB Locator found at the following URL:  <a href="http://www.cisco.com/go/mibs">http://www.cisco.com/go/mibs</a>

**RFCs**

RFCs	Title
RFC 2661	Layer Two Tunneling Protocol L2TP
RFC 2341	Cisco Layer Two Forwarding (Protocol) L2F
RFC 2516	A Method for Transmitting PPP Over Ethernet (PPPoE) (PPPoE Discovery)

**Technical Assistance**

Description	Link
<p>The Cisco Support website provides extensive online resources, including documentation and tools for troubleshooting and resolving technical issues with Cisco products and technologies.</p> <p>To receive security and technical information about your products, you can subscribe to various services, such as the Product Alert Tool (accessed from Field Notices), the Cisco Technical Services Newsletter, and Really Simple Syndication (RSS) Feeds.</p> <p>Access to most tools on the Cisco Support website requires a Cisco.com user ID and password.</p>	<a href="http://www.cisco.com/techsupport">http://www.cisco.com/techsupport</a>

## Feature Information for Configuring a Subscriber Service Switch Policy

The following table provides release information about the feature or features described in this module. This table lists only the software release that introduced support for a given feature in a given software release train. Unless noted otherwise, subsequent releases of that software release train also support that feature.

Use Cisco Feature Navigator to find information about platform support and Cisco software image support. To access Cisco Feature Navigator, go to [www.cisco.com/go/cfn](http://www.cisco.com/go/cfn). An account on Cisco.com is not required.

*Table 3: Feature Information for Configuring a Cisco Subscriber Service Switch Policy*

<b>Feature Name</b>	<b>Releases</b>	<b>Feature Configuration Information</b>
Subscriber Service Switch	Cisco IOS XE Release 2.1	<p>The Subscriber Service Switch provides the framework for the management and scalability of PPP sessions that are switched from one virtual PPP link to another. It gives Internet service providers (ISPs) the flexibility to determine which services to provide to subscribers, the number of subscribers, and how to define the services. The primary purpose of the Subscriber Service Switch is to direct PPP from one point to another using a Layer 2 subscriber policy.</p> <p>This feature was integrated into Cisco IOS XE Release 2.1.</p>