

CHAPTER 2

Installing the Node

This chapter describes how to install the node, and it includes the following sections:

- [Unpacking and Inspecting the Node, page 2-2](#)
- [Preparing for Node Installation, page 2-3](#)
- [Installing the Node In a Rack, page 2-5](#)
- [Initial Node Setup, page 2-9](#)



Note

Before you install, operate, or service a node, review the [Regulatory Compliance and Safety Information for Cisco UCS C-Series Servers](#) for important safety information.



Warning

IMPORTANT SAFETY INSTRUCTIONS

This warning symbol means danger. You are in a situation that could cause bodily injury. Before you work on any equipment, be aware of the hazards involved with electrical circuitry and be familiar with standard practices for preventing accidents. Use the statement number provided at the end of each warning to locate its translation in the translated safety warnings that accompanied this device.
Statement 1071

Unpacking and Inspecting the Node

**Caution**

When handling internal node components, wear an ESD strap and handle modules by the carrier edges only.

**Tip**

Keep the shipping container in case the node requires shipping in the future.

**Note**

The chassis is thoroughly inspected before shipment. If any damage occurred during transportation or any items are missing, contact your customer service representative immediately.

-
- Step 1** Remove the node from its cardboard container and save all packaging material.
- Step 2** Compare the shipment to the equipment list provided by your customer service representative. Verify that you have all items.
- Step 3** Check for damage and report any discrepancies or damage to your customer service representative. Have the following information ready:
- Invoice number of shipper (see the packing slip)
 - Model and serial number of the damaged unit
 - Description of damage
 - Effect of damage on the installation
-

Preparing for Node Installation

This section provides information about preparing for node installation, and it includes the following topics:

- [Installation Guidelines, page 2-3](#)
- [Rack Requirements, page 2-4](#)
- [Equipment Requirements, page 2-4](#)
- [Slide Rail Adjustment Range and Cable Management Arm Dimensions, page 2-4](#)

Installation Guidelines



Warning

To prevent the node from overheating, do not operate it in an area that exceeds the maximum recommended ambient temperature of: 40° C (104° F).

Statement 1047



Warning

The plug-socket combination must be accessible at all times, because it serves as the main disconnecting device.

Statement 1019



Warning

This product relies on the building's installation for short-circuit (overcurrent) protection. Ensure that the protective device is rated not greater than: 250 V, 15 A.

Statement 1005



Warning

Installation of the equipment must comply with local and national electrical codes.

Statement 1074



Caution

To ensure proper airflow it is necessary to rack the nodes using rail kits. Physically placing the units on top of one another or “stacking” without the use of the rail kits blocks the air vents on top of the nodes, which could result in overheating, higher fan speeds, and higher power consumption. We recommend that you mount your nodes on rail kits when you are installing them into the rack because these rails provide the minimal spacing required between the nodes. No additional spacing between the nodes is required when you mount the units using rail kits.

When you are installing a node, use the following guidelines:

- Ensure that there is adequate space around the node to allow for servicing the node and for adequate airflow. The airflow in this node is from front to back.
- Ensure that the air-conditioning meets the thermal requirements listed in the [Environmental Specifications, page A-2](#).

- Ensure that the cabinet or rack meets the requirements listed in the “[Rack Requirements](#)” section on [page 2-4](#).
- Ensure that the site power meets the power requirements listed in the [Power Specifications](#), [page A-3](#). If available, you can use an uninterruptible power supply (UPS) to protect against power failures.

Rack Requirements

This section provides the requirements for the standard open racks.

The rack must be of the following type:

- A standard 19-in. (48.3-cm) wide, four-post EIA rack, with mounting posts that conform to English universal hole spacing, per section 1 of ANSI/EIA-310-D-1992.
- The rack post holes can be square 0.38-inch (9.6 mm), round 0.28-inch (7.1 mm), #12-24 UNC, or #10-32 UNC when you use the supplied slide rails.
- The minimum vertical rack space per node must be one RU, equal to 1.75 in. (44.45 mm).

Equipment Requirements

The slide rails sold by Cisco for this node do not require tools for installation.

Supported Slide Rail Kits

This node supports two rail kit options:

- Cisco part UCSC-RAILB-M4= (ball-bearing rail kit).
- Cisco part UCSC-RAILF-M4= (friction rail kit).

Slide Rail Adjustment Range and Cable Management Arm Dimensions

The slide rails for this node have an adjustment range of 24 to 36 inches (610 to 914 mm).

The optional cable management arm (CMA) adds additional length requirements:

- The additional distance from the rear of the node to the rear of the CMA is 5.4 inches (137.4 mm).
- The total length of the node including the CMA is 35.2 inches (894 mm).

Installing the Node In a Rack

This section contains the following sections:

- [Installing the Slide Rails, page 2-5](#)
- [Installing the Cable Management Arm \(Optional\), page 2-8](#)
- [Reversing the Cable Management Arm \(Optional\), page 2-9](#)

Installing the Slide Rails

This section describes how to install the node in a rack using the rack kits that are sold by Cisco.



Warning

To prevent bodily injury when mounting or servicing this unit in a rack, you must take special precautions to ensure that the node remains stable. The following guidelines are provided to ensure your safety:

This unit should be mounted at the bottom of the rack if it is the only unit in the rack.

When mounting this unit in a partially filled rack, load the rack from the bottom to the top with the heaviest component at the bottom of the rack.

If the rack is provided with stabilizing devices, install the stabilizers before mounting or servicing the unit in the rack.
Statement 1006

Step 1

Attach the inner rails to the sides of the node:

- Align an inner rail with one side of the node so that the three keyed slots in the rail align with the three pegs on the side of the node (see [Figure 2-1](#)).
- Set the keyed slots over the pegs, and then slide the rail toward the front to lock it in place on the pegs. The front slot has a metal clip that locks over the front peg.
- Install the second inner rail to the opposite side of the node.

Figure 2-1 Attaching Inner Rail to Side of Node

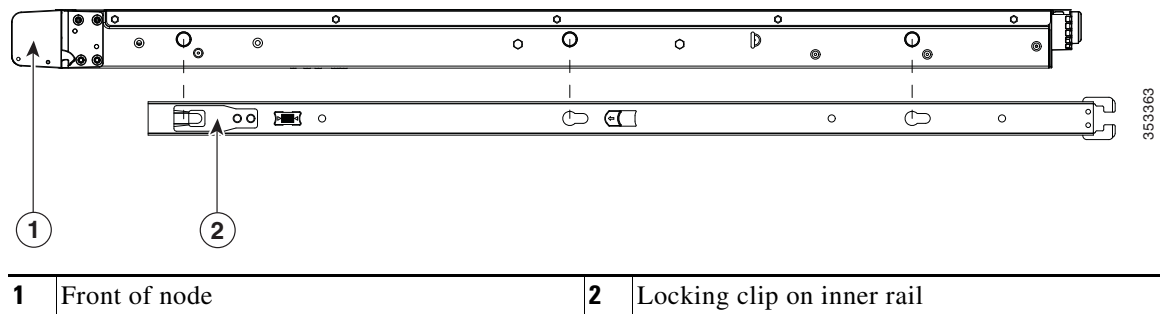

Step 2 Open the front securing plate on both slide-rail assemblies. The front end of the slide-rail assembly has a spring-loaded securing plate that must be open before you can insert the mounting pegs into the rack-post holes (see [Figure 2-2](#)).

On the *outside* of the assembly, push the green arrow button toward the rear to open the securing plate.

Figure 2-2 Front Securing Mechanism, Inside of Front End

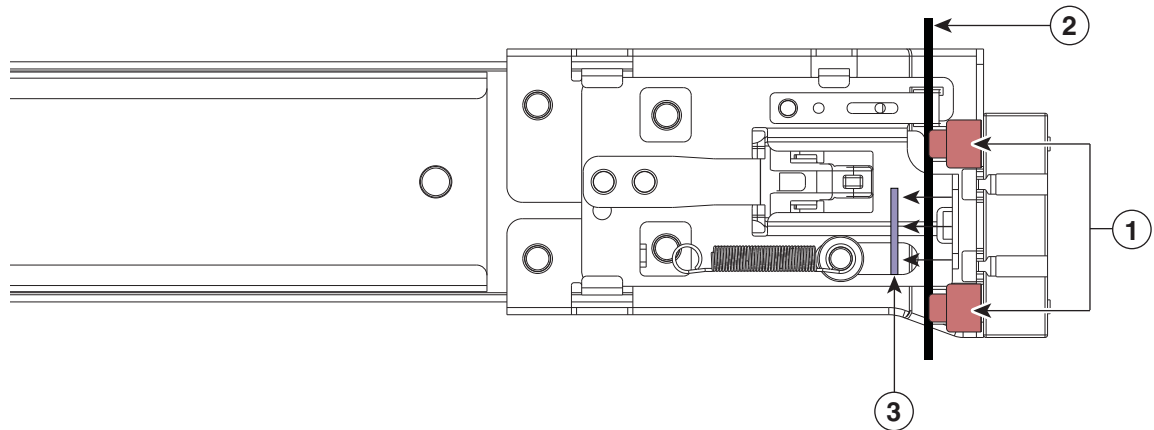

1	Front mounting pegs	3	Securing plate shown pulled back to open position
2	Rack post		

Step 3 Install the outer slide rails into the rack:

- a. Align one slide-rail assembly front end with the front rack-post holes that you want to use.

The slide rail front-end wraps around the outside of the rack post and the mounting pegs enter the rack-post holes from the outside-front (see [Figure 2-2](#)).



Note The rack post must be between the mounting pegs and the *open* securing plate.

- b. Push the mounting pegs into the rack-post holes from the outside-front.
- c. Press the securing plate release button, marked PUSH. The spring-loaded securing plate closes to lock the pegs in place.
- d. Adjust the slide-rail length, and then push the rear mounting pegs into the corresponding rear rack-post holes. The slide rail must be level front-to-rear.
The rear mounting pegs enter the rear rack-post holes from the inside of the rack post.
- e. Attach the second slide-rail assembly to the opposite side of the rack. Ensure that the two slide-rail assemblies are at the same height with each other and are level front-to-back.
- f. Pull the inner slide rails on each assembly out toward the rack front until they hit the internal stops and lock in place.

Step 4 Insert the node into the slide rails:



Caution

This node can weigh up to 67 pounds (59 kilograms) when fully loaded with components. We recommend that you use a minimum of two people or a mechanical lift when lifting the node. Attempting this procedure alone could result in personal injury or equipment damage.

- a. Align the rear of the inner rails that are attached to the node sides with the front ends of the empty slide rails on the rack.
- b. Push the inner rails into the slide rails on the rack until they stop at the internal stops.
- c. Slide the release clip toward the rear on both inner rails, and then continue pushing the node into the rack until its front slam latches engage with the rack posts.

Figure 2-3 Inner Rail Release Clip

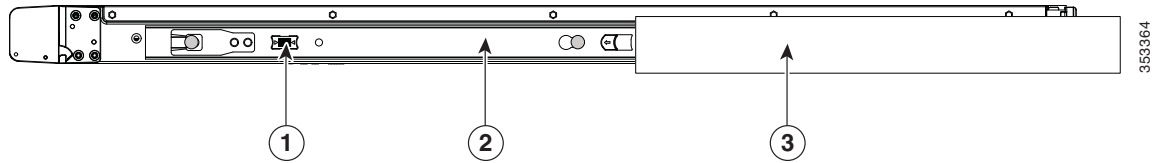

1	Inner rail release clip	3	Outer rail attached to rack post
2	Inner rail attached to node and inserted into outer rail		

Step 5 (Optional) Secure the node in the rack more permanently by using the two screws that are provided with the slide rails. Perform this step if you plan to move the rack with nodes installed.

With the node fully pushed into the slide rails, open a hinged slam latch lever on the front of the node and insert the screw through the hole that is under the lever. The screw threads into the static part of the rail on the rack post and prevents the node from being pulled out. Repeat for the opposite slam latch.

Installing the Cable Management Arm (Optional)



Note The CMA is reversible left to right. To reverse the CMA, see [Reversing the Cable Management Arm \(Optional\)](#), page 2-9 before installation.

- Step 1** With the node pushed fully into the rack, slide the CMA tab of the CMA arm that is farthest from the node onto the end of the stationary slide rail that is attached to the rack post (see [Figure 2-4](#)). Slide the tab over the end of the rail until it clicks and locks.
- Step 2** Slide the CMA tab that is closest to the node over the end of the inner rail that is attached to the node (see [Figure 2-4](#)). Slide the tab over the end of the rail until it clicks and locks.
- Step 3** Pull out the width-adjustment slider that is at the opposite end of the CMA assembly until it matches the width of your rack (see [Figure 2-4](#)).
- Step 4** Slide the CMA tab that is at the end of the width-adjustment slider onto the end of the stationary slide rail that is attached to the rack post (see [Figure 2-4](#)). Slide the tab over the end of the rail until it clicks and locks.
- Step 5** Open the hinged flap at the top of each plastic cable guide and route your cables through the cable guides as desired.

Figure 2-4 Attaching the Cable Management Arm to the Rear of the Slide Rails

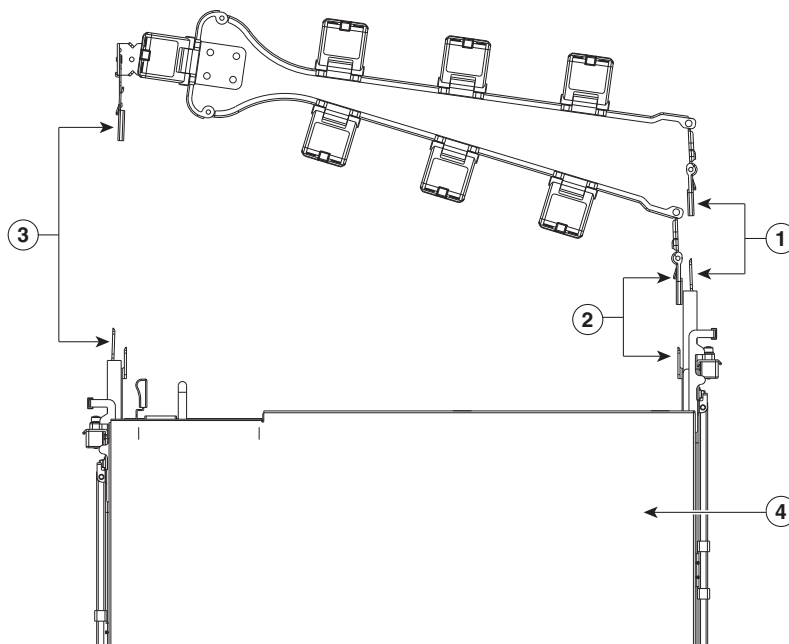

1	CMA tab on arm farthest from node and end of stationary outer slide rail	3	CMA tab on width-adjustment slider and end of stationary outer slide rail
2	CMA tab on arm closest to the node and end of inner slide rail attached to node	4	Rear of node

Reversing the Cable Management Arm (Optional)

- Step 1** Rotate the entire CMA assembly 180 degrees. The plastic cable guides must remain pointing upward.
- Step 2** Flip the tabs at the end of each CMA arm so that they point toward the rear of the node.
- Step 3** Pivot the tab that is at the end of the width-adjustment slider. Depress and hold the metal button on the outside of the tab and pivot the tab 180 degrees so that it points toward the rear of the node.

Figure 2-5 Reversing the CMA

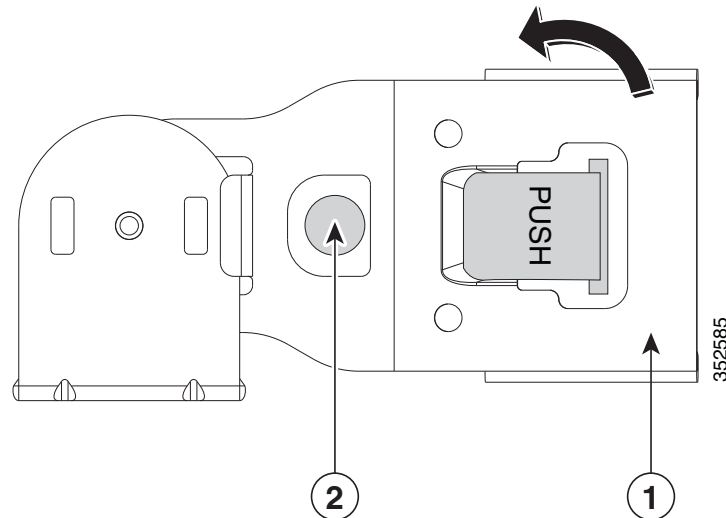

1	CMA tab on end of width-adjustment slider	2	Metal button for rotating
----------	---	----------	---------------------------

Initial Node Setup

Refer to the following documentation:

- For instructions on physically installing the nodes in racks, see [Installing the Node In a Rack, page 2-5](#)
- For installation instructions on configuring system fabric interconnects and connecting the HX Series HyperFlex nodes to the fabrics, refer to the [Cisco HyperFlex Systems Getting Started Guide](#).
- For instructions on adding the HX220c node as a compute-only node, see the “Adding a Compute Node” section in the [Cisco HyperFlex Systems Getting Started Guide](#).
- For instructions on starting the node in standalone mode for troubleshooting purposes only, see [Setting Up the Node in Standalone Mode, page 3-65](#).

