



Configuring VXLAN OAM

This chapter contains the following sections:

- [VXLAN OAM Overview, on page 1](#)
- [About VXLAN EVPN Loop Detection and Mitigation, on page 5](#)
- [Guidelines and Limitations for VXLAN NGOAM, on page 7](#)
- [Guidelines and Limitations for VXLAN EVPN Loop Detection and Mitigation, on page 7](#)
- [Configuring VXLAN OAM, on page 8](#)
- [Configuring NGOAM Profile, on page 12](#)
- [Configuring VXLAN EVPN Loop Detection and Mitigation, on page 13](#)
- [Configuring NGOAM Loop Detection for Layer-3 Interfaces, on page 14](#)
- [Detecting Loops and Bringing Up Ports On Demand, on page 16](#)
- [Configuration Examples for VXLAN EVPN Loop Detection and Mitigation, on page 17](#)

VXLAN OAM Overview

The VXLAN operations, administration, and maintenance (OAM) protocol is a protocol for installing, monitoring, and troubleshooting Ethernet networks to enhance management in VXLAN based overlay networks.

Similar to ping, traceroute, or pathtrace utilities that allow quick determination of the problems in the IP networks, equivalent troubleshooting tools have been introduced to diagnose the problems in the VXLAN networks. The VXLAN OAM tools, for example, ping, pathtrace, and traceroute provide the reachability information to the hosts and the VTEPs in a VXLAN network. The OAM channel is used to identify the type of the VXLAN payload that is present in these OAM packets.

There are two types of payloads supported:

- Conventional ICMP packet to the destination to be tracked
- Special NVO3 draft Tissa OAM header that carries useful information

The ICMP channel helps to reach the traditional hosts or switches that do not support the new OAM packet formats. The NVO3 draft Tissa channels helps to reach the supported hosts or switches and carries the important diagnostic information. The VXLAN NVO3 draft Tissa OAM messages may be identified via the reserved OAM EtherType or by using a well-known reserved source MAC address in the OAM packets depending on the implementation on different platforms. This constitutes a signature for recognition of the VXLAN OAM packets. The VXLAN OAM tools are categorized as shown in table below.

Table 1: VXLAN OAM Tools

Category	Tools
Fault Verification	Loopback Message
Fault Isolation	Path Trace Message
Performance	Delay Measurement, Loss Measurement
Auxiliary	Address Binding Verification, IP End Station Locator, Error Notification, OAM Command Messages, and Diagnostic Payload Discovery for ECMP Coverage

Loopback (Ping) Message

The loopback message (The ping and the loopback messages are the same and they are used interchangeably in this guide) is used for the fault verification. The loopback message utility is used to detect various errors and the path failures. Consider the topology in the following example where there are three core (spine) switches labeled Spine 1, Spine 2, and Spine 3 and five leaf switches connected in a Clos topology. The path of an example loopback message initiated from Leaf 1 for Leaf 5 is displayed when it traverses via Spine 3. When the loopback message initiated by Leaf 1 reaches Spine 3, it forwards it as VXLAN encapsulated data packet based on the outer header. The packet is not sent to the software on Spine 3. On Leaf 3, based on the appropriate loopback message signature, the packet is sent to the software VXLAN OAM module, that in turn, generates a loopback response that is sent back to the originator Leaf 1.

The loopback (ping) message can be destined to VM or to the (VTEP on) leaf switch. This ping message can use different OAM channels. If the ICMP channel is used, the loopback message can reach all the way to the VM if the VM's IP address is specified. If NVO3 draft Tissa channel is used, this loopback message is terminated on the leaf switch that is attached to the VM, as the VMs do not support the NVO3 draft Tissa headers in general. In that case, the leaf switch replies back to this message indicating the reachability of the VM. The ping message supports the following reachability options:

Ping

Check the network reachability (**Ping** command):

- From Leaf 1 (VTEP 1) to Leaf 2 (VTEP 2) (ICMP or NVO3 draft Tissa channel)
- From Leaf 1 (VTEP 1) to VM 2 (host attached to another VTEP) (ICMP or NVO3 draft Tissa channel)

Figure 1: Loopback Message

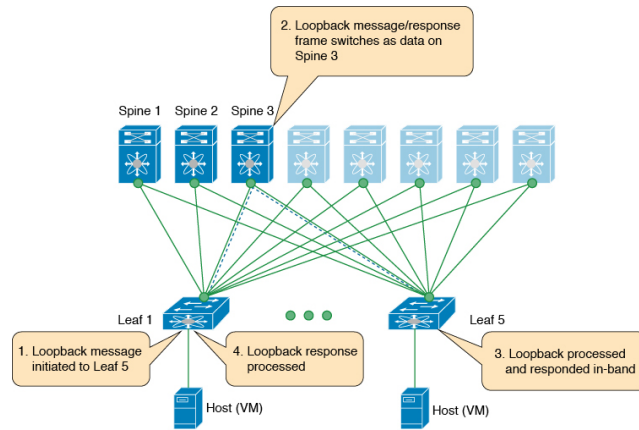
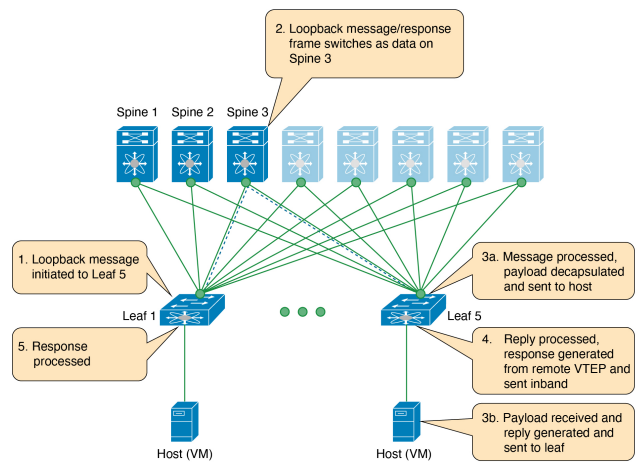

Figure 2: NVO3 Draft Tissa Ping to Remote VM



Traceroute or Pathtrace Message

The traceroute or pathtrace message is used for the fault isolation. In a VXLAN network, it may be desirable to find the list of switches that are traversed by a frame to reach the destination. When the loopback test from a source switch to a destination switch fails, the next step is to find out the offending switch in the path. The operation of the path trace message begins with the source switch transmitting a VXLAN OAM frame with a TTL value of 1. The next hop switch receives this frame, decrements the TTL, and on finding that the TTL is 0, it transmits a TTL expiry message to the sender switch. The sender switch records this message as an indication of success from the first hop switch. Then the source switch increases the TTL value by one in the next path trace message to find the second hop. At each new transmission, the sequence number in the message is incremented. Each intermediate switch along the path decrements the TTL value by 1 as is the case with regular VXLAN forwarding.

This process continues until a response is received from the destination switch, or the path trace process timeout occurs, or the hop count reaches a maximum configured value. The payload in the VXLAN OAM frames is referred to as the flow entropy. The flow entropy can be populated so as to choose a particular path among multiple ECMP paths between a source and destination switch. The TTL expiry message may also be

generated by the intermediate switches for the actual data frames. The same payload of the original path trace request is preserved for the payload of the response.

The traceroute and pathtrace messages are similar, except that traceroute uses the ICMP channel, whereas pathtrace use the NVO3 draft Tissa channel. Pathtrace uses the NVO3 draft Tissa channel, carrying additional diagnostic information, for example, interface load and statistics of the hops taken by these messages. If an intermediate device does not support the NVO3 draft Tissa channel, the pathtrace behaves as a simple traceroute and it provides only the hop information.

Traceroute

Trace the path that is traversed by the packet in the VXLAN overlay using **Traceroute** command:

- Traceroute uses the ICMP packets (channel-1), encapsulated in the VXLAN encapsulation to reach the host

Pathtrace

Trace the path that is traversed by the packet in the VXLAN overlay using the NVO3 draft Tissa channel with **Pathtrace** command:

- Pathtrace uses special control packets like NVO3 draft Tissa or TISSA (channel-2) to provide additional information regarding the path (for example, ingress interface and egress interface). These packets terminate at VTEP and they does not reach the host. Therefore, only the VTEP responds.
- Beginning with NX-OS release 9.3(3), the `Received` field of the **show ngoam pathtrace statistics summary** command indicates all pathtrace requests received by the node on which the command is executed regardless of whether the request was destined to that node.

Figure 3: Traceroute Message

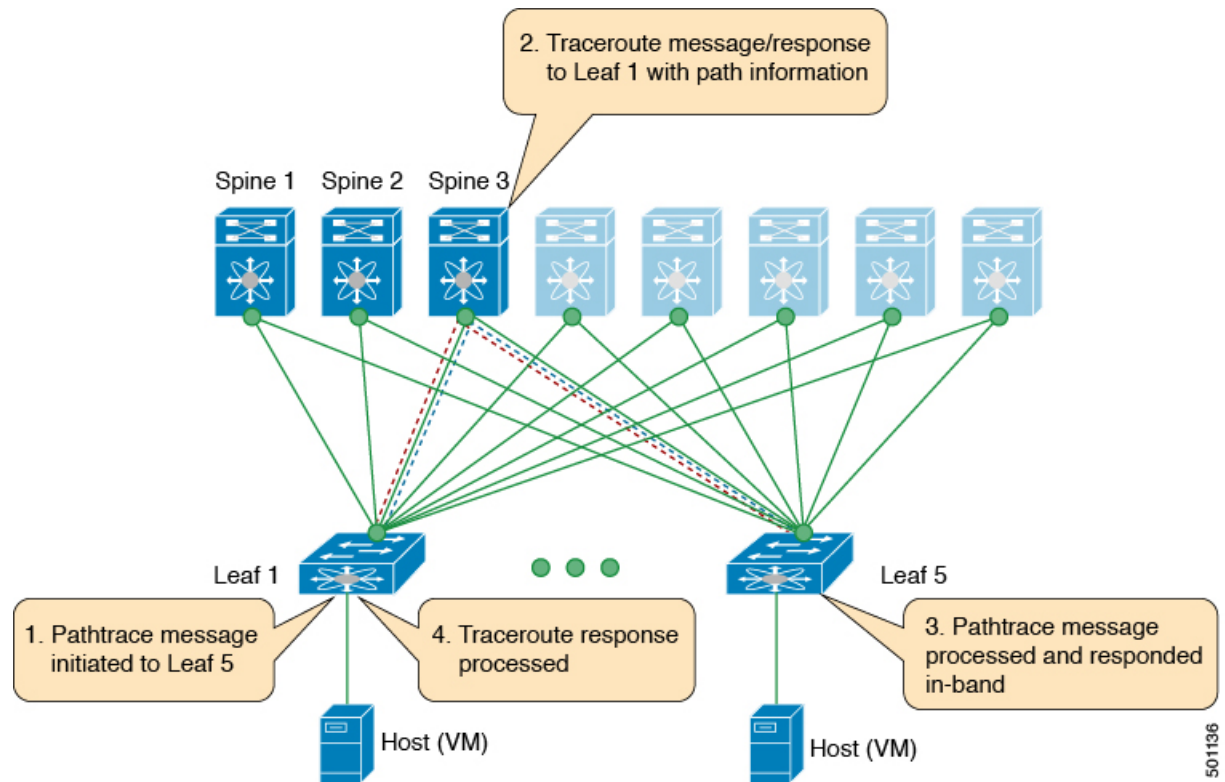

501136

About VXLAN EVPN Loop Detection and Mitigation

Loops usually occur in a VXLAN EVPN fabric due to incorrect cabling on the south side (access side) of the fabric. Once broadcast packets are injected into a network with a loop, the frame remains bridged in the loop. As more broadcast frames enter the loop, they accumulate and can cause a serious disruption of services.

Cisco NX-OS Release 9.3(5) introduces VXLAN EVPN loop detection and mitigation. This feature detects Layer 2 loops in a single VXLAN EVPN fabric or a Multi-Site environment. It operates at the port/VLAN level and disables the VLAN(s) on each port where a loop is detected. Administrators are also notified (via syslog) about the condition. In this way, the feature ensures that the network remains up and available.

The following figure shows an EVPN fabric in which two leaf devices (Leaf1 and Leaf2) are directly connected on the south side due to incorrect cabling. In this topology, Leaf3 forwards an L2 broadcast frame to Leaf1. Then the broadcast frame is repeatedly forwarded between Leaf1 and Leaf2 through the south side and the fabric. The forwarding continues until the incorrect cabling is fixed.

Figure 4: Two Leaf Nodes Directly Connected

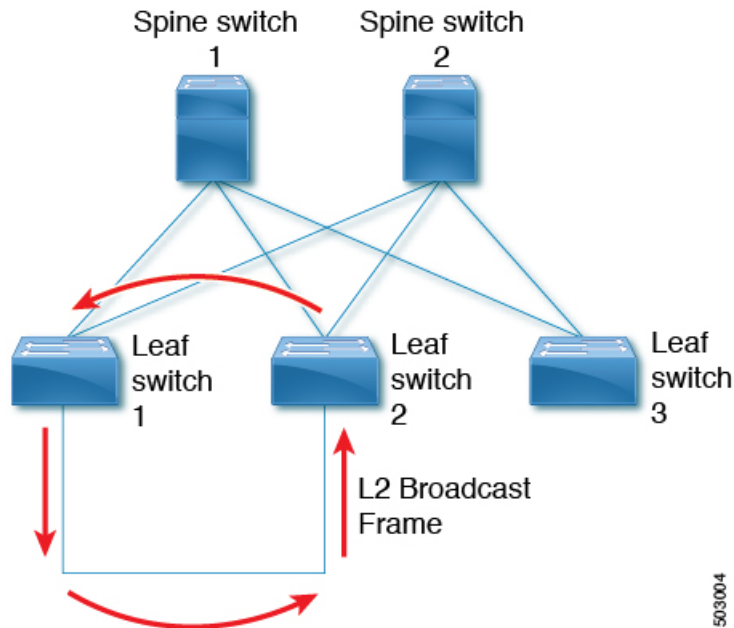

This feature operates in three phases:

1. Loop Detection: Sends a loop detection probe under the following circumstances: when requested by a client, as part of a periodic probe task, and as soon as any port comes up.
2. Loop Mitigation: Blocks the VLANs on a port once a loop has been discovered and displays a syslog message similar to the following:

```
2020 Jan 14 09:58:44 Leaf1 %NGOAM-4-SLD_LOOP_DETECTED: Loop detected - Blocking vlan
1001 :: Eth1/3
```

Because loops can lead to incorrect local MAC address learning, this phase also flushes the local and remote MAC addresses. Doing so removes any MAC addresses that are incorrectly learned.

In the previous figure, MAC addresses can be incorrectly learned because packets from hosts sitting behind the remote leaf (Leaf3) can reach both Leaf1 and Leaf2 from the access side. As a result, the hosts incorrectly appear local to Leaf1 and Leaf2, which causes the leafs to learn their MAC addresses.

3. Loop Recovery: Once a loop is detected on a particular port or VLAN and the recovery interval has passed, recovery probes are sent to determine if the loop still exists. When NGOAM recovers from the loop, a syslog message similar to the following appears:

```
2020 Jan 14 09:59:38 Leaf1 %NGOAM-4-SLD_LOOP_GONE: Loop cleared - Enabling vlan 1001
:: Eth1/3
```



Note The default logging level for NGOAM does not generate a syslog message. Modifying the logging level of NGOAM to 5 with "logging level ngoam 5" will result in a syslog message being generated when a loop is detected.

Guidelines and Limitations for VXLAN NGOAM

VXLAN NGOAM has the following guidelines and limitations:

- Beginning with Cisco NX-OS Release 9.2(3), support is added for Cisco Nexus 9504 and 9508 switches with -R line cards.
- Beginning with Cisco NX-OS Release 9.3(3), support is added for the Cisco Nexus 9300-GX platform switches.
- Beginning with Cisco NX-OS Release 9.3(5), support is added for the Cisco Nexus 9300-FX3 platform switches.
- Beginning with Cisco NX-OS Release 10.2(3)F, the VXLAN NGOAM is supported on the Cisco Nexus 9300-GX2 platform switches.
- Beginning with Cisco NX-OS Release 10.4(1)F, the VXLAN NGOAM is supported on the Cisco Nexus 9332D-H2R switches.
- Beginning with Cisco NX-OS Release 10.4(2)F, the VXLAN NGOAM is supported on the Cisco Nexus 9340LD-H1 switches.
- Beginning with Cisco NX-OS Release 10.4(3)F, the VXLAN NGOAM is supported on the Cisco Nexus 9364C-H1 switches.
- Beginning with Cisco NX-OS Release 10.2(3)F, you do not have to enable the VXLAN feature using the **feature nv overlay** command to use the NGOAM feature on intermediate nodes.
- Beginning with Cisco NX-OS Release 10.4(3)F, NGOAM ping, traceroute, and pathtrace are supported on Cisco Nexus 9800 switches, but Xconnect and Southbound Loop Detection (SLD) are not supported.
- Beginning with Cisco NX-OS Release 10.4(3)F, NGOAM Southbound Loop Detection (SLD) for Layer-3 ethernet and Layer-3 port-channel interfaces is supported on Cisco Nexus Platform Series switches. However, sub-interfaces are not supported.

Guidelines and Limitations for VXLAN EVPN Loop Detection and Mitigation

VXLAN EVPN loop detection and mitigation has the following guidelines and limitations:

- VXLAN EVPN loop detection and mitigation is supported beginning with Cisco NX-OS Release 9.3(5).
- The following platforms support VXLAN EVPN loop detection and mitigation:
 - Cisco Nexus 9332C and 9364C platform switches
 - Cisco Nexus 9300-EX platform switches
 - Cisco Nexus 9300-FX/FX2/FXP platform switches
 - Cisco Nexus 9300-GX platform switches
 - Cisco Nexus 9500 platform switches with -EX/FX line cards

- Beginning with Cisco NX-OS Release 10.1(1) VXLAN EVPN loop detection and mitigation is supported on Cisco Nexus 9300-FX3 and -GX platform switches.
- Beginning with Cisco NX-OS Release 10.2(3)F, the VXLAN EVPN loop detection and mitigation is supported on the Cisco Nexus 9300-GX2 platform switches.
- Beginning with Cisco NX-OS Release 10.4(1)F, the VXLAN EVPN loop detection and mitigation is supported on the Cisco Nexus 9332D-H2R switches.
- Beginning with Cisco NX-OS Release 10.4(2)F, the VXLAN EVPN loop detection and mitigation is supported on the Cisco Nexus 9340LD-H1 switches.
- Beginning with Cisco NX-OS Release 10.4(3)F, the VXLAN EVPN loop detection and mitigation is supported on the Cisco Nexus 9364C-H1 switches.
- VXLAN EVPN loop detection and mitigation is supported in both STP and STP-less environments.
- To be able to detect loops across sites for VXLAN EVPN Multi-Site deployments, the **ngoam loop-detection** command needs to be configured on all border gateways in the site where the feature is being deployed.
- VXLAN EVPN loop detection and mitigation isn't supported with the following features:
 - Private VLANs
 - VLAN translation
 - ESI-based multihoming
 - VXLAN Cross Connect
 - Q-in-VNI
 - EVPN segment routing (Layer 2)



Note Ports or VLANs configured with these features must be excluded from VXLAN EVPN loop detection and mitigation. You can use the **disable** `{vlan vlan-range}` [**port** `port-range`] command to exclude them.

Configuring VXLAN OAM

Before you begin

As a prerequisite, ensure that the VXLAN configuration is complete.



Note Beginning with Cisco NX-OS Release 10.2(3), you do not have to enable the VXLAN feature for configuring the NGOAM feature on intermediate nodes.

SUMMARY STEPS

1. switch# **configure terminal**
2. switch(config)# **feature ngoam**
3. switch(config)# **hardware access-list tcam region arp-ether 256 double-wide**
4. switch(config)# **ngoam install acl**
5. (Optional) **bcm-shell module 1 "fp show group 62"**

DETAILED STEPS

	Command or Action	Purpose
Step 1	switch# configure terminal	Enters global configuration mode.
Step 2	switch(config)# feature ngoam	Enters the NGOAM feature.
Step 3	switch(config)# hardware access-list tcam region arp-ether 256 double-wide	For Cisco Nexus 9300 platform switches with Network Forwarding Engine (NFE), configure the TCAM region for ARP-ETHER using this command. This step is essential to program the ACL rule in the hardware and it is a prerequisite before installing the ACL rule. Note Configuring the TCAM region requires the node to be rebooted.
Step 4	switch(config)# ngoam install acl	Installs the NGOAM Access Control List (ACL). Note This command is deprecated beginning with Cisco NX-OS Release 9.3(5) and is required only for earlier releases.
Step 5	(Optional) bcm-shell module 1 "fp show group 62"	For Cisco Nexus 9300 Series switches with Network Forwarding Engine (NFE), complete this verification step. After entering the command, perform a lookup for entry/eid with data=0x8902 under EtherType.

Example

See the following examples of the configuration topology.

Figure 5: VXLAN Network

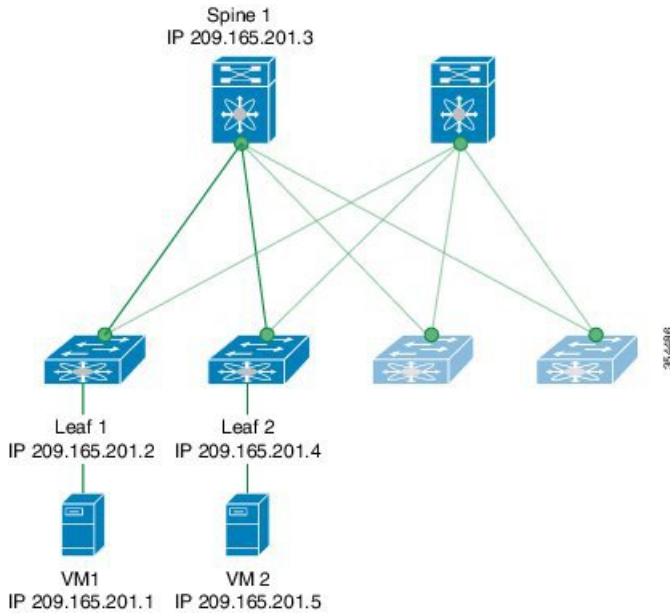

VXLAN OAM provides the visibility of the host at the switch level, that allows a leaf to ping the host using the **ping nve** command.

The following examples display how to ping from Leaf 1 to VM2 via Spine 1 with channel 1 (unique loopback) and with channel 2 (NVO3 Draft Tissa):

```
switch# ping nve ip 209.165.201.5 vrf vni-31000 source 1.1.1.1 verbose
```

```
Codes: '!' - success, 'Q' - request not sent, '.' - timeout,
'D' - Destination Unreachable, 'X' - unknown return code,
'm' - malformed request(parameter problem),
'c' - Corrupted Data/Test, '#' - Duplicate response
```

```
Sender handle: 34
! sport 40673 size 39,Reply from 209.165.201.5,time = 3 ms
! sport 40673 size 39,Reply from 209.165.201.5,time = 1 ms
! sport 40673 size 39,Reply from 209.165.201.5,time = 1 ms
! sport 40673 size 39,Reply from 209.165.201.5,time = 1 ms
! sport 40673 size 39,Reply from 209.165.201.5,time = 1 ms
Success rate is 100 percent (5/5), round-trip min/avg/max = 1/4/18 ms
Total time elapsed 49 ms
```

<<<< add space here

```
switch# ping nve ip unknown vrf vni-31000 payload ip 209.165.201.5 209.165.201.4 payload-end
verify-host
```

<snip>

```
Sender handle: 34
!!!!
Success rate is 100 percent (5/5), round-trip min/avg/max = 1/4/18 ms
Total time elapsed 49 ms
```



Note The source ip-address 1.1.1.1 used in the above example is a loopback interface that is configured on Leaf 1 in the same VRF as the destination ip-address. For example, the VRF in this example is vni-31000.

The following example displays how to traceroute from Leaf 1 to VM 2 via Spine 1.

```
switch# traceroute nve ip 209.165.201.5 vrf vni-31000 source 1.1.1.1 verbose
```

```
Codes: '!' - success, 'Q' - request not sent, '.' - timeout,
'D' - Destination Unreachable, 'X' - unknown return code,
'm' - malformed request(parameter problem),
'c' - Corrupted Data/Test, '#' - Duplicate response
```

```
Traceroute request to peer ip 209.165.201.4 source ip 209.165.201.2
Sender handle: 36
 1 !Reply from 209.165.201.3,time = 1 ms
 2 !Reply from 209.165.201.4,time = 2 ms
 3 !Reply from 209.165.201.5,time = 1 ms
```

The following example displays how to pathtrace from Leaf 2 to Leaf 1.

```
switch# pathtrace nve ip 209.165.201.4 vni 31000 verbose
```

```
Path trace Request to peer ip 209.165.201.4 source ip 209.165.201.2
```

```
Sender handle: 42
TTL  Code  Reply                               IngressI/f  EgressI/f  State
=====
 1      !Reply from 209.165.201.3,  Eth5/5/1    Eth5/5/2    UP/UP
 2      !Reply from 209.165.201.4,  Eth1/3      Unknown     UP/DOWN
```

The following example displays how to MAC ping from Leaf 2 to Leaf 1 using NVO3 draft Tissa channel:

```
switch# ping nve mac 0050.569a.7418 2901 ethernet 1/51 profile 4 verbose
```

```
Codes: '!' - success, 'Q' - request not sent, '.' - timeout,
'D' - Destination Unreachable, 'X' - unknown return code,
'm' - malformed request(parameter problem),
'c' - Corrupted Data/Test, '#' - Duplicate response
```

```
Sender handle: 408
!!!!Success rate is 100 percent (5/5), round-trip min/avg/max = 4/4/5 ms
Total time elapsed 104 ms
```

```
switch# show run ngoam
feature ngoam
ngoam profile 4
oam-channel 2
ngoam install acl
```

The following example displays how to pathtrace based on a payload from Leaf 2 to Leaf 1:

```
switch# pathtrace nve ip unknown vrf vni-31000 payload mac-addr 0050.569a.d927 0050.569a.a4fa
ip 209.165.201.5 209.165.201.1 port 15334 12769 proto 17 payload-end
```

```
Codes: '!' - success, 'Q' - request not sent, '.' - timeout,
'D' - Destination Unreachable, 'X' - unknown return code,
'm' - malformed request(parameter problem),
'c' - Corrupted Data/Test, '#' - Duplicate response
```

```
Path trace Request to peer ip 209.165.201.4 source ip 209.165.201.2
Sender handle: 46
TTL Code Reply IngressI/f EgressI/f State
=====
```

```
1 !Reply from 209.165.201.3, Eth5/5/1 Eth5/5/2 UP/UP
2 !Reply from 209.165.201.4, Eth1/3 Unknown UP/DOWN
```



Note When the total hop count to final destination is more than 5, the path trace default TTL value is 5. Use **max-ttl** option to finish VXLAN OAM path trace completely.

For example: **pathtrace nve ip unknown vrf vrf-vni13001 payload ip 200.1.1.71 200.1.1.23 payload-end verbose max-ttl 10**

Configuring NGOAM Profile

Complete the following steps to configure NGOAM profile.

SUMMARY STEPS

1. switch(config)# [no] feature ngoam
2. switch(config)# [no] ngoam profile <profile-id>
3. switch(config-ng-oam-profile)# ?

DETAILED STEPS

	Command or Action	Purpose
Step 1	switch(config)# [no] feature ngoam	Enables or disables NGOAM feature
Step 2	switch(config)# [no] ngoam profile <profile-id>	Configures OAM profile. The range for the profile-id is <1 – 1023>. This command does not have a default value. Enters the config-ngoam-profile submode to configure NGOAM specific commands. Note All profiles have default values and the show run all CLI command displays them. The default values are not visible through the show run CLI command.
Step 3	switch(config-ng-oam-profile)# ? Example:	Displays the options for configuring NGOAM profile.

	Command or Action	Purpose
	<pre> switch(config-ng-oam-profile)# ? description Configure description of the profile dot1q Encapsulation dot1q/bd flow Configure ngoam flow hop Configure ngoam hop count interface Configure ngoam egress interface no Negate a command or set its defaults oam-channel Oam-channel used payload Configure ngoam payload sport Configure ngoam Udp source port range </pre>	

Example

See the following examples for configuring an NGOAM profile and for configuring NGOAM flow.

```

switch(config)#
ngoam profile 1
oam-channel 1
flow forward
payload pad 0x2
sport 12345, 54321

switch(config-ngoam-profile)#flow {forward }
Enters config-ngoam-profile-flow submode to configure forward flow entropy specific
information
                    
```

Configuring VXLAN EVPN Loop Detection and Mitigation

Follow these steps to configure VXLAN loop detection and mitigation.

Before you begin

Enable the NGOAM feature.

Use the following commands to create space for the TCAM ing-sup region:

```

hardware access-list tcam region ing-racl 0
hardware access-list tcam region ing-sup 768
                    
```



Note Configuring the TCAM region requires the node to be rebooted.

SUMMARY STEPS

1. switch# **configure terminal**
2. switch(config)# **[no] ngoam loop-detection**
3. (Optional) switch(config-ng-oam-loop-detection)# **[no] disable {vlan vlan-range} [port port-range]**
4. (Optional) switch(config-ng-oam-loop-detection)# **[no] periodic-probe-interval value**
5. (Optional) switch(config-ng-oam-loop-detection)# **[no] port-recovery-interval value**
6. (Optional) switch# **show ngoam loop-detection summary**

DETAILED STEPS

	Command or Action	Purpose
Step 1	switch# configure terminal	Enters global configuration mode.
Step 2	switch(config)# [no] ngoam loop-detection	Enables VXLAN EVPN loop detection and mitigation for all VLANs or ports. This feature is disabled by default.
Step 3	(Optional) switch(config-ng-oam-loop-detection)# [no] disable {vlan vlan-range} [port port-range]	Disables VXLAN EVPN loop detection and mitigation for specific VLANs or ports and brings up any loop-detected ports. The no form of this command resumes active monitoring of these VLANs or ports.
Step 4	(Optional) switch(config-ng-oam-loop-detection)# [no] periodic-probe-interval value	Specifies how often periodic loop-detection probes are sent. The range is from 60 seconds to 3600 seconds (60 minutes). The default value is 300 seconds (5 minutes).
Step 5	(Optional) switch(config-ng-oam-loop-detection)# [no] port-recovery-interval value	Once a port or VLAN is shut down, specifies how often recovery probes are sent. The range is from 300 seconds to 3600 seconds (60 minutes). The default value is 600 seconds (10 minutes).
Step 6	(Optional) switch# show ngoam loop-detection summary	Displays the loop-detection configuration and current loop summary.

What to do next

Configure a QoS policy on the spine. (For an example configuration, see [Configuration Examples for VXLAN EVPN Loop Detection and Mitigation](#), on page 17).

Configuring NGOAM Loop Detection for Layer-3 Interfaces

Beginning with NX-OS release 10.4(3)F, Cisco Nexus switches support enabling NGOAM Southbound Loop Detection (SLD) on a Layer-3 (L3) Ethernet and L3 port-channel interfaces.

When enabled on an L3 interface, this feature sends periodic probes to detect loops in the downstream tenant's Layer-2 domain. It continues to monitor for loops until the user takes action to correct the condition.

To enable NGOAM loop detection on Ethernet and L3 port-channel interfaces, follow these steps:

Before you begin

Enable the NGOAM feature.

Use the following commands to create space for the TCAM ing-sup region:

```
hardware access-list tcam region ing-racl 0
hardware access-list tcam region ing-sup 768
```



Note Configuring the TCAM region requires the node to be rebooted.

SUMMARY STEPS

1. **configure terminal**
2. **[no] ngoam loop-detection**
3. **[no] l3 ethernet port *port-range***
4. **[no] l3 port-channel port *port-range***
5. (Optional) **show ngoam loop-detection status l3**

DETAILED STEPS

	Command or Action	Purpose
Step 1	<p>configure terminal</p> <p>Example:</p> <pre>switch# config terminal switch(config)#</pre>	Enters global configuration mode.
Step 2	<p>[no] ngoam loop-detection</p> <p>Example:</p> <pre>switch(config)# ngoam loop-detection</pre>	Enables VXLAN EVPN loop detection and mitigation for all VLANs or ports. This feature is disabled by default.
Step 3	<p>[no] l3 ethernet port <i>port-range</i></p> <p>Example:</p> <pre>switch(config-ng-oam-loop-detection)# l3 ethernet port Eth1/49</pre>	Enables the L3 loop-detection on ethernet interfaces. Use the no form of this command to disable the L3 loop-detection on ethernet interfaces.
Step 4	<p>[no] l3 port-channel port <i>port-range</i></p> <p>Example:</p> <pre>switch(config-ng-oam-loop-detection)# l3 port-channel port port-channell</pre>	Enables the L3 loop-detection on port-channel interfaces. Use the no form of this command to disable the L3 loop-detection on port-channel interfaces.
Step 5	<p>(Optional) show ngoam loop-detection status l3</p> <p>Example:</p> <pre>switch# show ngoam loop-detection status l3 Port Status NumLoops DetectionTime ClearedTime</pre>	Displays the loops detected on L3 interfaces.

Command or Action	Purpose
Eth1/49 BLOCKED 1 Tue Jun 6 20:01:27 2023 Never	

Detecting Loops and Bringing Up Ports On Demand

Follow the steps in this section to detect loops or bring up blocked ports on demand.

Before you begin

Enable VXLAN EVPN loop detection and mitigation.

SUMMARY STEPS

1. (Optional) switch# **ngoam loop-detection probe** {vlan *vlan-range*} [**port** *port-range*]
2. (Optional) switch# **ngoam loop-detection bringup** {vlan *vlan-range*} [**port** *port-range*]
3. (Optional) switch# **show ngoam loop-detection status** [**history**] [vlan *vlan-range*] [**port** *port-range*]

DETAILED STEPS

	Command or Action	Purpose
Step 1	(Optional) switch# ngoam loop-detection probe {vlan <i>vlan-range</i> } [port <i>port-range</i>]	Sends a loop-detection probe on the specified VLAN or port and a notification as to whether the probe was successfully sent.
Step 2	(Optional) switch# ngoam loop-detection bringup {vlan <i>vlan-range</i> } [port <i>port-range</i>]	Brings up the VLANs or ports that were blocked earlier. This command also clears any entries stuck in the NGOAM. Note It can take up to two port-recovery intervals for the ports to come up after a loop is cleared. You can speed up the recovery by manually overriding the timer with the ngoam loop-detection bringup vlan {vlan <i>vlan-range</i> } [port <i>port-range</i>] command.
Step 3	(Optional) switch# show ngoam loop-detection status [history] [vlan <i>vlan-range</i>] [port <i>port-range</i>]	Displays the loop-detection status for the VLAN or port. The status can be one of the following: <ul style="list-style-type: none"> • BLOCKED—The VLAN or port is shut down because a loop has been detected. • FORWARDING—A loop has not been detected, and the VLAN or port is operational. • RECOVERING—Recovery probes are being sent to determine if a previously detected loop still exists. The history option displays blocked, forwarding, and recovering ports. Without the history option, the command displays only blocked and recovering ports.

Configuration Examples for VXLAN EVPN Loop Detection and Mitigation

The following example shows how to configure VXLAN EVPN loop detection and mitigation:

```
switch(config)# ngoam loop-detection
switch(config-ng-oam-loop-detection)# periodic-probe-interval 200
switch(config-ng-oam-loop-detection)# port-recovery-interval 300
```

The following example shows how to disable VXLAN EVPN loop detection and mitigation on specific VLANs or VLAN ports:

```
switch(config-ng-oam-loop-detection)# disable vlan 1200 port ethernet 1/1
switch(config-ng-oam-loop-detection)# disable vlan 1300
```

The following example shows how to configure a QoS policy on the spine and apply it to all of the spine interfaces to which the loop-detection-enabled leaf is connected:

```
class-map type qos match-any Spine-DSCP56
match dscp 56
policy-map type qos Spine-DSCP56
class Spine-DSCP56
set qos-group 7

interface Ethernet1/31
mtu 9216
no link dfe adaptive-tuning
service-policy type qos input Spine-DSCP5663
no ip redirects
ip address 27.4.1.2/24
ip router ospf 200 area 0.0.0.0
ip pim sparse-mode
no shutdown
```

The following sample output shows the loop-detection configuration and current loop summary:

```
switch# show ngoam loop-detection summary
Loop detection:enabled
Periodic probe interval: 200
Port recovery interval: 300
Number of vlans: 1
Number of ports: 1
Number of loops: 1
Number of ports blocked: 1
Number of vlans disabled: 0
Number of ports disabled: 0
Total number of probes sent: 214
Total number of probes received: 102
Next probe window start: Thu May 14 15:14:23 2020 (0 seconds)
Next recovery window start: Thu May 14 15:54:23 2020 (126 seconds)
```

The following sample output shows the loop-detection status for the specified VLANs or ports with and without the **history** option:

```
switch# show ngoam loop-detection status
VlanId Port Status NumLoops Detection Time ClearedTime
=====
```

```
100 Eth1/3 BLOCKED 1 Tue Apr 14 20:07:50.313 2020 Never
```

```
switch# show ngoam loop-detection status history
```

VlanId	Port	Status	NumLoops	Detection Time	ClearedTime
100	Eth1/3	BLOCKED	1	Tue Apr 14 20:07:50.313 2020	Never
200	Eth1/2	FORWARDING	1	Tue Apr 14 21:19:52.215 2020	May 11 21:30:54.830 2020