



Configuring Layer 2 Data Center Interconnect

This section contains an example of how to configure a Layer 2 Data Center Interconnect (DCI) with the use of a Virtual Port-Channel (vPC).

- [Overview, on page 1](#)
- [Example of Layer 2 Data Center Interconnect, on page 2](#)

Overview

The purpose of a Data Center Interconnect (DCI) is to extend specific VLANs between different data centers. DCI offers Layer 2 adjacency for servers and Network Attached Storage (NAS) devices that are separated by large distances.

Beginning with Cisco NX-OS release 7.0(3)I2(2), Cisco Nexus 9000 series switches support DCI with FHRP isolation. However DCI with FHRP isolation is not supported on Cisco Nexus 9500 switches with N9K-X9636C-R and N9K-X9636Q-R line cards. Creating a single logical link between multiple sites with vPC allows you to take advantage of the benefits of STP isolation using BPDU filtering across the DCI vPC port-channel. With this configuration, Bridge Protocol Data Unit (BPDU) does not cross between data centers, effectively isolating the STP fault domain between sites.

Cisco Nexus 9000 series switches support DCI with FHRP isolation. However DCI with FHRP isolation is not supported on Cisco Nexus 9500 switches with N9K-X9636C-R and N9K-X9636Q-R line cards. Creating a single logical link between multiple sites with vPC allows you to take advantage of the benefits of STP isolation using BPDU filtering across the DCI vPC port-channel. With this configuration, Bridge Protocol Data Unit (BPDU) does not cross between data centers, effectively isolating the STP fault domain between sites.



Note vPC is to interconnect a maximum of two data centers.



Note The supported platforms include Cisco Nexus 9500 Series switches with N9K-X9636C-R, N9K-X9636Q-R, N9K-X9636C-RX line cards.

Example of Layer 2 Data Center Interconnect

The following is an example configuration of a Layer 2 Data Center Interconnect (DCI) with use of vPC. The example allows for First Hop Redundancy Protocol (FHRP) isolation.



Note vPC and Hot Standby Routing Protocol (HSRP) have already been configured.



Note Link Aggregation Control Protocol (LACP) should be used on the vPC link, which acts as the DCI.

Figure 1: Dual Layer 2/Layer 3 POD Interconnect

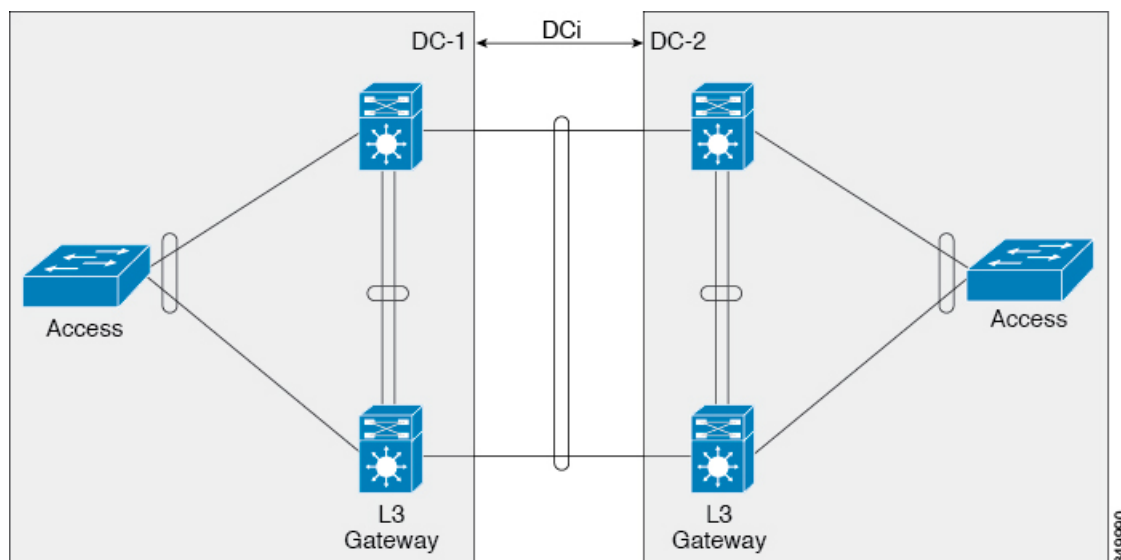

In this example, the Layer 3 (L3) gateway is configured on the same vPC pair and acts as the DCI. In order to isolate the Hot Standby Routing Protocol (HSRP), you must configure a Port Access Control List (PACL) on the DCI port-channel and disable HSRP Gratuitous Address Resolution Protocols (ARPs) (GARPs) on the Switched Virtual Interfaces (SVIs) for the VLANs that move across the DCI.

```
ip access-list DENY_HSRP_IP
 10 deny udp any 224.0.0.2/32 eq 1985
 20 deny udp any 224.0.0.102/32 eq 1985
 30 permit ip any any

interface <DCI-Port-Channel>
 ip port access-group DENY_HSRP_IP in

interface Vlan <x>
 no ip arp gratuitous hsrp duplicate
```