



Configuring Basic Interface Parameters

This chapter describes how to configure the basic interface parameters on Cisco NX-OS devices.

- [About the Basic Interface Parameters, on page 1](#)
- [Guidelines and Limitations, on page 8](#)
- [Default Settings, on page 9](#)
- [Configuring the Basic Interface Parameters, on page 9](#)
- [Verifying the Basic Interface Parameters, on page 39](#)
- [Monitoring the Interface Counters, on page 40](#)

About the Basic Interface Parameters

Following parameters are supported on Cisco Nexus 3548 switches:

Description

For the Ethernet and management interfaces, you can configure the description parameter to provide a recognizable name for the interface. Using a unique name for each interface allows you to quickly identify the interface when you are looking at a listing of multiple interfaces.

For information about setting the description parameter for port-channel interfaces, see the “Configuring a Port-Channel Description” section. For information about configuring this parameter for other interfaces, see the “Configuring the Description” section.

Beacon

The beacon mode allows you to identify a physical port by flashing its link state LED with a green light. By default, this mode is disabled. To identify the physical port for an interface, you can activate the beacon parameter for the interface.

For information about configuring the beacon parameter, see the “Configuring the Beacon Mode” section.

Error Disabled

A port is in the error-disabled (err-disabled) state when the port is enabled administratively (using the **no shutdown** command) but disabled at runtime by any process. For example, if UDLD detects a unidirectional

link, the port is shut down at runtime. However, because the port is administratively enabled, the port status displays as err-disable. Once a port goes into the err-disable state, you must manually reenabling it or you can configure a timeout value that provides an automatic recovery. By default, the automatic recovery is not configured, and by default, the err-disable detection is enabled for all causes.

When an interface is in the err-disabled state, use the **errdisable detect cause** command to find information about the error.

You can configure the automatic error-disabled recovery timeout for a particular error-disabled cause and configure the recovery period.

The **errdisable recovery cause** command provides an automatic recovery after 300 seconds.

You can use the **errdisable recovery interval** command to change the recovery period within a range of 30 to 65535 seconds. You can also configure the recovery timeout for a particular err-disable cause.

If you do not enable the error-disabled recovery for the cause, the interface stays in the error-disabled state until you enter the **shutdown** and **no shutdown** commands. If the recovery is enabled for a cause, the interface is brought out of the error-disabled state and allowed to retry operation once all the causes have timed out. Use the **show interface status err-disabled** command to display the reason behind the error.

MDIX

The medium dependent interface crossover (MDIX) parameter enables or disables the detection of a crossover connection between devices. This parameter applies only to copper interfaces. By default, this parameter is enabled.

For information about configuring the MDIX parameter, see the [Configuring the MDIX Parameter](#) section.

Interface Status Error Policy

Cisco NX-OS policy servers such as Access Control List (ACL) Manager and Quality of Service (QoS) Manager, maintain a policy database. A policy is defined through the command-line interface.

Policies are pushed when you configure a policy on an interface to ensure that policies that are pushed are consistent with the hardware policies. To clear the errors and to allow the policy programming to proceed with the running configuration, enter the **no shutdown** command. If the policy programming succeeds, the port is allowed to come up. If the policy programming fails, the configuration is inconsistent with the hardware policies and the port is placed in an error-disabled policy state. The error-disabled policy state remains and the information is stored to prevent the same port from being brought up in the future. This process helps to avoid unnecessary disruption to the system.

Modifying Interface MTU Size

The maximum transmission unit (MTU) size specifies the maximum frame size that an Ethernet port can process. For transmissions to occur between two ports, you must configure the same MTU size for both ports. A port drops any frames that exceed its MTU size.

Cisco NX-OS allows you to configure MTU on an interface, with options to configure it on different level in the protocol stack. By default, each interface has an MTU of 1500 bytes, which is the IEEE 802.3 standard for Ethernet frames. Larger MTU sizes are possible for more efficient processing of data to allow different application requirements. The larger frames, are also called jumbo frames, can be up to 9216 bytes in size.

MTU is configured per interface, where an interface can be a Layer 2 or a Layer 3 interface. For a Layer 2 interface, you can configure the MTU size with one of two values, the value system default MTU value or the system jumbo MTU value. The system default MTU value is 1500 bytes. Every Layer 2 interface is configured with this value by default. You can configure an interface with the default system jumbo MTU value, that is 9216 bytes. To allow an MTU value from 1500 through 9216, you must adjust the system jumbo MTU to an appropriate value where interface can be configured with the same value.



Note You can change the system jumbo MTU size. When the value is changed, the Layer 2 interfaces that use the system jumbo MTU value, will automatically changes to the new system jumbo MTU value.

A Layer 3 interface, can be Layer 3 physical interface (configure with no switchport), switch virtual interface (SVI), and sub-interface, you can configure an MTU size between 576 and 9216 bytes.

For information about setting the MTU size, see the *Configuring the MTU Size* section.

Bandwidth

Ethernet ports have a fixed bandwidth of 1,000,000 Kb at the physical layer. Layer 3 protocols use a bandwidth value that you can set for calculating their internal metrics. The value that you set is used for informational purposes only by the Layer 3 protocols—it does not change the fixed bandwidth at the physical layer. For example, the Enhanced Interior Gateway Routing Protocol (EIGRP) uses the minimum path bandwidth to determine a routing metric, but the bandwidth at the physical layer remains at 1,000,000 Kb.

For information about configuring the bandwidth parameter for port-channel interfaces, see the “Configuring the Bandwidth and Delay for Informational Purposes” section. For information about configuring the bandwidth parameter for other interfaces, see the “Configuring the Bandwidth” section.

Throughput Delay

Specifying a value for the throughput-delay parameter provides a value used by Layer 3 protocols; it does not change the actual throughput delay of an interface. The Layer 3 protocols can use this value to make operating decisions. For example, the Enhanced Interior Gateway Routing Protocol (EIGRP) can use the delay setting to set a preference for one Ethernet link over another, if other parameters such as link speed are equal. The delay value that you set is in the tens of microseconds.

For information about configuring the bandwidth parameter for port-channel interfaces, see the “Configuring the Bandwidth and Delay for Informational Purposes” section. For information about configuring the throughput-delay parameter for other interfaces, see the “Configuring the Throughput Delay” section.

Administrative Status

The administrative-status parameter determines whether an interface is up or down. When an interface is administratively down, it is disabled and unable to transmit data. When an interface is administratively up, it is enabled and able to transmit data.

For information about configuring the administrative status parameter for port-channel interfaces, see the “Shutting Down and Restarting the Port-Channel Interface” section. For information about configuring the administrative-status parameter for other interfaces, see the “Shutting Down and Activating the Interface” section.

Unidirectional Link Detection Parameter

UDLD Overview

The Cisco-proprietary Unidirectional Link Detection (UDLD) protocol allows devices that are connected through fiber-optic or copper (for example, Category 5 cabling) Ethernet cables to monitor the physical configuration of the cables and detect when a unidirectional link exists. When a device detects a unidirectional link, UDLD shuts down the affected LAN port and alerts the user. Unidirectional links can cause a variety of problems.

UDLD performs tasks that autonegotiation cannot perform, such as detecting the identities of neighbors and shutting down misconnected LAN ports. When you enable both autonegotiation and UDLD, Layer 1 detections work to prevent physical and logical unidirectional connections and the malfunctioning of other protocols.

A unidirectional link occurs whenever traffic transmitted by the local device over a link is received by the neighbor but traffic transmitted from the neighbor is not received by the local device. If one of the fiber strands in a pair is disconnected, as long as autonegotiation is active, the link does not stay up. In this case, the logical link is undetermined, and UDLD does not take any action. If both fibers are working normally at Layer 1, UDLD determines whether those fibers are connected correctly and whether traffic is flowing bidirectionally between the correct neighbors. This check cannot be performed by autonegotiation, because autonegotiation operates at Layer 1.

The Cisco Nexus device periodically transmits UDLD frames to neighbor devices on LAN ports with UDLD enabled. If the frames are echoed back within a specific time frame and they lack a specific acknowledgment (echo), the link is flagged as unidirectional and the LAN port is shut down. Devices on both ends of the link must support UDLD in order for the protocol to successfully identify and disable unidirectional links. You can configure the transmission interval for the UDLD frames, either globally or for the specified interfaces.



Note By default, UDLD is locally disabled on copper LAN ports to avoid sending unnecessary control traffic on this type of media.

The figure shows an example of a unidirectional link condition. Device B successfully receives traffic from device A on the port. However, device A does not receive traffic from device B on the same port. UDLD detects the problem and disables the port.

Figure 1: Unidirectional Link

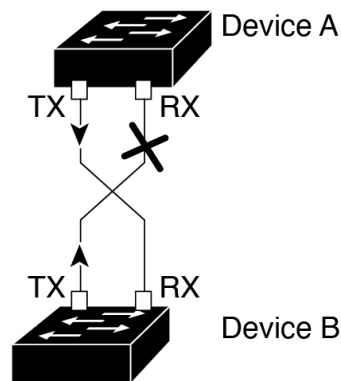

504782

Default UDLD Configuration

The following table shows the default UDLD configuration.

Table 1: UDLD Default Configuration

Feature	Default Value
UDLD global enable state	Globally disabled
UDLD per-port enable state for fiber-optic media	Enabled on all Ethernet fiber-optic LAN ports
UDLD per-port enable state for twisted-pair (copper) media	Disabled on all Ethernet 10/100 and 1000BASE-TX LAN ports
UDLD aggressive mode	Disabled
UDLD message interval	15 seconds

For information about configuring the UDLD for the device and its port, see the “Configuring the UDLD Mode” section.

UDLD Normal and Aggressive Modes

UDLD supports Normal and Aggressive modes of operation. By default, Normal mode is enabled.

In Normal mode, UDLD detects the following link errors by examining the incoming UDLD packets from the peer port:

- Empty echo packet
- Uni-direction
- TX/RX loop
- Neighbor mismatch

By default, UDLD aggressive mode is disabled. You can configure UDLD aggressive mode only on point-to-point links between network devices that support UDLD aggressive mode.

If UDLD aggressive mode is enabled, when a port on a bidirectional link that has a UDLD neighbor relationship established stops receiving UDLD frame, UDLD tries to re-establish the connection with the neighbor. After eight failed retries, the port is disabled.

In the following scenarios, enabling the UDLD aggressive mode disables one of the ports to prevent the discarding of traffic.

- One side of a link has a port stuck (both transmission and receive)
- One side of a link remains up while the other side of the link is down



Note You enable the UDLD aggressive mode globally to enable that mode on all the fiber ports. You must enable the UDLD aggressive mode on copper ports on specified interfaces.



Tip When a line card upgrade is being performed during an in-service software upgrade (ISSU) and some of the ports on the line card are members of a Layer 2 port channel and are configured with UDLD aggressive mode, if you shut down one of the remote ports, UDLD puts the corresponding port on the local device into an error-disabled state. This behavior is correct.

To restore service after the ISSU has completed, enter the **shutdown** command followed by the **no shutdown** command on the local port.

Port-Channel Parameters

A port channel is an aggregation of physical interfaces that comprise a logical interface. You can bundle up to 32 individual interfaces into a port channel to provide increased bandwidth and redundancy. Port channeling also load balances traffic across these physical interfaces. The port channel stays operational if at least one physical interface within the port channel is operational.

You can create Layer 3 port channels by bundling compatible Layer 3 interfaces.

Any configuration changes that you apply to the port channel are applied to each interface member of that port channel.

For information about port channels and for information about configuring port channels, see Chapter 6, “Configuring Port Channels.”

Port Profiles

On Cisco Nexus 3600 Series switches, you can create a port profile that contains many interface commands and apply that port profile to a range of interfaces. Each port profile can be applied only to a specific type of interface; the choices are as follows:

- Ethernet
- VLAN network interface
- Port channel

When you choose Ethernet or port channel as the interface type, the port profile is in the default mode which is Layer 3. Enter the **switchport** command to change the port profile to Layer 2 mode.

You inherit the port profile when you attach the port profile to an interface or range of interfaces. When you attach, or inherit, a port profile to an interface or range of interfaces, the system applies all the commands in that port profile to the interfaces. Additionally, you can have one port profile inherit the settings from another port profile. Inheriting another port profile allows the initial port profile to assume all of the commands of the second, inherited, port profile that do not conflict with the initial port profile. Four levels of inheritance are supported. The same port profile can be inherited by any number of port profiles.

The system applies the commands inherited by the interface or range of interfaces according to the following guidelines:

- Commands that you enter under the interface mode take precedence over the port profile’s commands if there is a conflict. However, the port profile retains that command in the port profile.
- The port profile’s commands take precedence over the default commands on the interface, unless the port-profile command is explicitly overridden by the default command.

- When a range of interfaces inherits a second port profile, the commands of the initial port profile override the commands of the second port profile if there is a conflict.
- After you inherit a port profile onto an interface or range of interfaces, you can override individual configuration values by entering the new value at the interface configuration level. If you remove the individual configuration values at the interface configuration level, the interface uses the values in the port profile again.
- There are no default configurations associated with a port profile.

A subset of commands are available under the port-profile configuration mode, depending on which interface type you specify.



Note You cannot use port profiles with Session Manager. See the *Cisco Nexus 3600 Series NX-OS System Management Configuration Guide* for information about Session Manager.

To apply the port-profile configurations to the interfaces, you must enable the specific port profile. You can configure and inherit a port profile onto a range of interfaces prior to enabling the port profile. You would then enable that port profile for the configurations to take effect on the specified interfaces.

If you inherit one or more port profiles onto an original port profile, only the last inherited port profile must be enabled; the system assumes that the underlying port profiles are enabled.

When you remove a port profile from a range of interfaces, the system undoes the configuration from the interfaces first and then removes the port-profile link itself. Also, when you remove a port profile, the system checks the interface configuration and either skips the port-profile commands that have been overridden by directly entered interface commands or returns the command to the default value.

If you want to delete a port profile that has been inherited by other port profiles, you must remove the inheritance before you can delete the port profile.

You can also choose a subset of interfaces from which to remove a port profile from among that group of interfaces that you originally applied the profile. For example, if you configured a port profile and configured ten interfaces to inherit that port profile, you can remove the port profile from just some of the specified ten interfaces. The port profile continues to operate on the remaining interfaces to which it is applied.

If you delete a specific configuration for a specified range of interfaces using the interface configuration mode, that configuration is also deleted from the port profile for that range of interfaces only. For example, if you have a channel group inside a port profile and you are in the interface configuration mode and you delete that port channel, the specified port channel is also deleted from the port profile as well.

Just as in the device, you can enter a configuration for an object in port profiles without that object being applied to interfaces yet. For example, you can configure a virtual routing and forward (VRF) instance without it being applied to the system. If you then delete that VRF and related configurations from the port profile, the system is unaffected.

After you inherit a port profile on an interface or range of interfaces and you delete a specific configuration value, that port-profile configuration is not operative on the specified interfaces.

If you attempt to apply a port profile to the wrong type of interface, the system returns an error.

When you attempt to enable, inherit, or modify a port profile, the system creates a checkpoint. If the port-profile configuration fails, the system rolls back to the prior configuration and returns an error. A port profile is never only partially applied.

Guidelines and Limitations

Basic interface parameters have the following configuration guidelines and limitations:

- MDIX is enabled by default on copper ports. It is not possible to disable it.
- **show** commands with the **internal** keyword are not supported.
- Fiber-optic Ethernet ports must use Cisco-supported transceivers. To verify that the ports are using Cisco-supported transceivers, use the **show interface transceivers** command. Interfaces with Cisco-supported transceivers are listed as functional interfaces.
- A port can be either a Layer 2 or a Layer 3 interface; it cannot be both simultaneously.

By default, each port is a Layer 3 interface.

You can change a Layer 3 interface into a Layer 2 interface by using the **switchport** command. You can change a Layer 2 interface into a Layer 3 interface by using the **no switchport** command.

- You usually configure Ethernet port speed and duplex mode parameters to auto to allow the system to negotiate the speed and duplex mode between ports. If you decide to configure the port speed and duplex modes manually for these ports, consider the following:
 - Before you configure the speed and duplex mode for an Ethernet or management interface, see the Default Settings section for the combinations of speeds and duplex modes that can be configured at the same time.
 - If you set the Ethernet port speed to auto, the device automatically sets the duplex mode to auto.
 - If you enter the **no speed** command, the device automatically sets both the speed and duplex parameters to auto (the **no speed** command produces the same results as the **speed auto** command).
 - If you configure an Ethernet port speed to a value other than auto (for example, 1G, 10G, or 40G), you must configure the connecting port to match. Do not configure the connecting port to negotiate the speed.
 - To configure speed, duplex, and automatic flow control for an Ethernet interface, you can use the **negotiate auto** command. To disable automatic negotiation, use the **no negotiate auto** command.



Note The device cannot automatically negotiate the Ethernet port speed and duplex mode if the connecting port is configured to a value other than auto.



Caution Changing the Ethernet port speed and duplex mode configuration might shut down and reenable the interface.

- For BASE-T copper ports, auto-negotiation is enabled even when fixed speed is configured.
- If cable length is more than 5 meters, Auto Negotiation is not supported. This cable length limitation is applicable only to copper cables and not applicable to optical cables.

Default Settings

The following lists the default settings for the basic interface parameters.

Parameter	Default
Description	Blank
Beacon	Disabled
Bandwidth	Data rate of interface
Throughput delay	100 microseconds
Administrative status	Shutdown
MTU	1500 bytes
UDLD global	Globally disabled
UDLD per-port enable state for fiber-optic media	Enabled on all Ethernet fiber-optic LAN ports
UDLD per-port enable state for copper media	Disabled on all Ethernet 1G, 10G, or 40G LAN ports
UDLD message interval	Disabled
UDLD aggressive mode	Disabled
Error disable	Disabled
Error disable recovery	Disabled
Error disable recovery interval	300 seconds

Configuring the Basic Interface Parameters

When you configure an interface, you must specify the interface before you can configure its parameters.

Specifying the Interfaces to Configure

Before you begin

Before you can configure the parameters for one or more interfaces of the same type, you must specify the type and the identities of the interfaces.

The following table shows the interface types and identities that you should use for specifying the Ethernet and management interfaces.

Table 2: Information Needed to Identify an Interface for Configurations

Interface Type	Identity
Ethernet	I/O module slot numbers and port numbers on the module
Management	0 (for port 0)

The interface range configuration mode allows you to configure multiple interfaces with the same configuration parameters. After you enter the interface range configuration mode, all command parameters you enter are attributed to all interfaces within that range until you exit out of the interface range configuration mode.

You enter a range of interfaces using dashes (-) and commas (.). Dashes separate contiguous interfaces and commas separate noncontiguous interfaces. When you enter noncontiguous interfaces, you must enter the media type for each interface.

This example shows how to configure a contiguous interface range:

```
switch(config)# interface ethernet 2/29-30
switch(config-if-range)#
```

This example shows how to configure a noncontiguous interface range:

```
switch(config)# interface ethernet 2/29, ethernet 2/33, ethernet 2/35
switch(config-if-range)#
```

You can specify subinterfaces in a range only when the subinterfaces are on the same port, for example, 2/29.1-2. But you cannot specify the subinterfaces in a range of ports, for example, you cannot enter 2/29.2-2/30.2. You can specify two of the subinterfaces discretely, for example, you can enter 2/29.2, 2/30.2.

This example shows how to configure a breakout cable:

```
switch(config)# interface ethernet 1/2/1
switch(config-if-range)#
```

SUMMARY STEPS

1. **configure terminal**
2. **interface interface**

DETAILED STEPS

	Command or Action	Purpose
Step 1	configure terminal Example: <pre>switch# configure terminal switch(config)#</pre>	Enters global configuration mode.
Step 2	interface interface Example: <pre>switch(config)# interface ethernet 2/1 switch(config-if)#</pre> Example:	Specifies the interface that you are configuring. You can specify the interface type and identity. For an Ethernet port, use ethernet slot/port . For the management interface, use mgmt0 . Examples:

	Command or Action	Purpose
	<pre>switch(config)# interface mgmt0 switch(config-if)#</pre>	<ul style="list-style-type: none"> The 1st example shows how to specify the slot 2, port 1 Ethernet interface. The 2nd example shows how to specify the management interface. <p>Note You do not need to add a space between the interface type and identity (port or slot/port number) For example, for the Ethernet slot 4, port 5 interface, you can specify either “ethernet 4/5” or “ethernet4/5.” The management interface is either “mgmt0” or “mgmt 0.”</p> <p>When you are in the interface configuration mode, the commands that you enter configure the interface that you specified for this mode.</p>

Configuring the Description

You can provide textual interface descriptions for the Ethernet and management interfaces.

SUMMARY STEPS

1. **configure terminal**
2. **interface** *interface*
3. **description** *text*
4. **show interface** *interface*
5. **exit**
6. **copy running-config startup-config**

DETAILED STEPS

	Command or Action	Purpose
Step 1	configure terminal Example: <pre>switch# configure terminal switch(config)#</pre>	Enters global configuration mode.
Step 2	interface <i>interface</i> Example: <pre>switch(config)# interface ethernet 2/1 switch(config-if)#</pre> Example: <pre>switch(config)# interface mgmt0 switch(config-if)#</pre>	Specifies the interface that you are configuring. You can specify the interface type and identity. For an Ethernet port, use ethernet <i>slot/port</i> . For the management interface, use mgmt0 . Examples: <ul style="list-style-type: none"> The 1st example shows how to specify the slot 2, port 1 Ethernet interface.

	Command or Action	Purpose
		<ul style="list-style-type: none"> The 2nd example shows how to specify the management interface.
Step 3	description <i>text</i> Example: <pre>switch(config-if)# description Ethernet port 3 on module 1 switch(config-if)#</pre>	Specifies the description for the interface.
Step 4	show interface <i>interface</i> Example: <pre>switch(config)# show interface ethernet 2/1</pre>	(Optional) Displays the interface status, which includes the description parameter.
Step 5	exit Example: <pre>switch(config-if)# exit switch(config)#</pre>	Exits the interface mode.
Step 6	copy running-config startup-config Example: <pre>switch(config)# copy running-config startup-config</pre>	(Optional) Copies the running configuration to the startup configuration.

Example

This example shows how to set the interface description to Ethernet port 24 on module 3:

```
switch# configure terminal
switch(config)# interface ethernet 3/24
switch(config-if)# description server1
switch(config-if)#
```

The output of the **show interface eth** command is enhanced as shown in the following example:

```
Switch# show version
Software
BIOS: version 06.26
NXOS: version 6.1(2)I2(1) [build 6.1(2)I2.1]
BIOS compile time: 01/15/2014
NXOS image file is: bootflash://n9000-dk9.6.1.2.I2.1.bin
NXOS compile time: 2/25/2014 2:00:00 [02/25/2014 10:39:03]
```

```
switch# show interface ethernet 6/36
Ethernet6/36 is up
admin state is up, Dedicated Interface
Hardware: 40000 Ethernet, address: 0022.bdf6.bf91 (bia 0022.bdf8.2bf3)
Internet Address is 192.168.100.1/24
MTU 9216 bytes, BW 40000000 Kbit, DLY 10 usec
```

Configuring the Beacon Mode

You can enable the beacon mode for an Ethernet port to flash its LED to confirm its physical location.

SUMMARY STEPS

1. **configure terminal**
2. **interface ethernet *slot/port***
3. **[no] beacon**
4. **show interface ethernet *slot/port***
5. **exit**
6. **copy running-config startup-config**

DETAILED STEPS

	Command or Action	Purpose
Step 1	configure terminal Example: <pre>switch# configure terminal switch(config)#</pre>	Enters global configuration mode.
Step 2	interface ethernet <i>slot/port</i> Example: <pre>switch(config)# interface ethernet 3/1 switch(config-if)#</pre>	Specifies an interface to configure, and enters interface configuration mode.
Step 3	[no] beacon Example: <pre>switch(config-if)# beacon switch(config-if)#</pre>	Enables the beacon mode or disables the beacon mode. The default mode is disabled.
Step 4	show interface ethernet <i>slot/port</i> Example: <pre>switch(config-if)# show interface ethernet 2/1 switch(config-if)#</pre>	(Optional) Displays the interface status, which includes the beacon mode state.
Step 5	exit Example: <pre>switch(config-if)# exit switch(config)#</pre>	Exits the interface mode.
Step 6	copy running-config startup-config Example: <pre>switch(config)# copy running-config startup-config</pre>	(Optional) Copies the running configuration to the startup configuration.

Example

This example shows how to enable the beacon mode for the Ethernet port 3/1:

```
switch# configure terminal
switch(config)# interface ethernet 3/1
switch(config-if)# beacon
switch(config-if)#
```

This example shows how to disable the beacon mode for the Ethernet port 3/1:

```
switch# configure terminal
switch(config)# interface ethernet 3/1
switch(config-if)# no beacon
switch(config-if)#
```

This example shows how to configure the dedicated mode for Ethernet port 4/17 in the group that includes ports 4/17, 4/19, 4/21, and 4/23:

```
switch# configure terminal
switch(config)# interface ethernet 4/17, ethernet 4/19, ethernet 4/21, ethernet 4/23
switch(config-if)# shutdown
switch(config-if)# interface ethernet 4/17
switch(config-if)# no shutdown
switch(config-if)#
```

Configuring the Error-Disabled State

You can view the reason that an interface moves to the error-disabled state and configure automatic recovery.

Enabling the Error-Disabled Recovery

You can specify the application to bring the interface out of the error-disabled state and retry coming up. It retries after 300 seconds, unless you configure the recovery timer (see the **errdisable recovery interval** command).

SUMMARY STEPS

1. **configure terminal**
2. **errdisable recovery cause** {all | bpduguard | failed-port-state | link-flap | loopback | miscabling | psecure-violation | security-violation | storm-control | udld | vpc-peerlink}
3. **show interface status err-disabled**
4. **copy running-config startup-config**

DETAILED STEPS

	Command or Action	Purpose
Step 1	configure terminal Example: switch# configure terminal switch(config)#	Enters global configuration mode.

	Command or Action	Purpose
Step 2	errdisable recovery cause {all bpduguard failed-port-state link-flap loopback miscabling psecure-violation security-violation storm-control udld vpc-peerlink} Example: <pre>switch(config)# errdisable recovery cause all switch(config-if)#</pre>	Specifies a condition under which the interface automatically recovers from the error-disabled state, and the device retries bringing the interface up. The device waits 300 seconds to retry. The default is disabled.
Step 3	show interface status err-disabled Example: <pre>switch(config)# show interface status err-disabled switch(config-if)#</pre>	(Optional) Displays information about error-disabled interfaces.
Step 4	copy running-config startup-config Example: <pre>switch(config)# copy running-config startup-config</pre>	(Optional) Copies the running configuration to the startup configuration.

Example

This example shows how to enable error-disabled recovery under all conditions:

```
switch(config)# errdisable recovery cause all
switch(config)#
```

Enabling the Error-Disable Detection

You can enable error-disable detection in an application. As a result, when a cause is detected on an interface, the interface is placed in an error-disabled state, which is an operational state that is similar to the link-down state.

SUMMARY STEPS

1. **configure terminal**
2. **errdisable detect cause** {acl-exception | all | link-flap | loopback}
3. **shutdown**
4. **no shutdown**
5. **show interface status err-disabled**
6. **copy running-config startup-config**

DETAILED STEPS

	Command or Action	Purpose
Step 1	configure terminal Example:	Enters global configuration mode.

	Command or Action	Purpose
	switch# configure terminal switch(config)#	
Step 2	errdisable detect cause {acl-exception all link-flap loopback} Example: switch(config)# errdisable detect cause all switch(config-if)#	Specifies a condition under which to place the interface in an error-disabled state. The default is enabled.
Step 3	shutdown Example: switch(config-if)# shutdown switch(config)#	Brings the interface down administratively. To manually recover the interface from the error-disabled state, enter this command first.
Step 4	no shutdown Example: switch(config-if)# no shutdown switch(config)#	Brings the interface up administratively and enables the interface to recover manually from the error-disabled state.
Step 5	show interface status err-disabled Example: switch(config)# show interface status err-disabled	(Optional) Displays information about error-disabled interfaces.
Step 6	copy running-config startup-config Example: switch(config)# copy running-config startup-config	(Optional) Copies the running configuration to the startup configuration.

Example

This example shows how to enable the error-disabled detection in all cases:

```
switch(config)# errdisable detect cause all
switch(config)#
```

Configuring the Error-Disabled Recovery Interval

You can configure the error-disabled recovery timer value.

SUMMARY STEPS

1. **configure terminal**
2. **errdisable recovery interval *interval***
3. **show interface status err-disabled**
4. **copy running-config startup-config**

DETAILED STEPS

	Command or Action	Purpose
Step 1	configure terminal Example: <pre>switch# configure terminal switch(config)#</pre>	Enters global configuration mode.
Step 2	errdisable recovery interval <i>interval</i> Example: <pre>switch(config)# errdisable recovery interval 32 switch(config-if)#</pre>	Specifies the interval for the interface to recover from the error-disabled state. The range is from 30 to 65535 seconds, and the default is 300 seconds.
Step 3	show interface status err-disabled Example: <pre>switch(config)# show interface status err-disabled switch(config-if)#</pre>	(Optional) Displays information about error-disabled interfaces.
Step 4	copy running-config startup-config Example: <pre>switch(config)# copy running-config startup-config</pre>	(Optional) Copies the running configuration to the startup configuration.

Example

This example shows how to configure the error-disabled recovery timer to set the interval for recovery to 32 seconds:

```
switch(config)# errdisable recovery interval 32
switch(config)#
```

Configuring the MDIX Parameter

To detect the type of connection (crossover or straight) with another copper Ethernet port, enable the medium dependent independent crossover (MDIX) parameter for the local port. By default, this parameter is enabled.

Before you begin

Enable MDIX for the remote port.

SUMMARY STEPS

1. **configure terminal**
2. **interface ethernet *slot / port***
3. **mdix auto**
4. **show interface ethernet *slot / port***
5. **exit**
6. **copy running-config startup-config**

DETAILED STEPS

	Command or Action	Purpose
Step 1	configure terminal Example: switch# configure terminal switch(config)#	Enters global configuration mode.
Step 2	interface ethernet slot / port Example: switch(config)# interface ethernet 3/1 switch(config-if)#	Specifies an interface to configure, and enters into interface configuration mode.
Step 3	mdix auto Example: switch(config)# mdix auto switch(config-if)#	Specifies whether to enable or disable MDIX detection for the port.
Step 4	show interface ethernet slot / port Example: switch(config)# show interface ethernet 3/1 switch(config-if)#	Displays the interface status, which includes the MDIX status.
Step 5	exit Example: switch(config)# exit	Exits the interface mode.
Step 6	copy running-config startup-config Example: switch(config)# copy running-config startup-config	(Optional) Copies the running configuration to the startup configuration.

Example

This example shows how to enable MDIX for Ethernet port 3/1:

```
switch# configure terminal
switch(config)# interface ethernet 3/1
switch(config-if)# mdix auto
switch(config-if)#
```

This example shows how to disable MDIX for Ethernet port 3/1:

```
switch# configure terminal
switch(config)# interface ethernet 3/1
switch(config-if)# no mdix
switch(config-if)#
```

Configuring the MTU Size

MTU is configured per interface, where the interface can be a Layer 2 or a Layer 3 interface. Every interface has default MTU of 1500 bytes. This value is called system default MTU. You can configure a Layer 2 interface, with a value of 9216 bytes, which is the default value of the system jumbo MTU. To allow an MTU value that is between 1500 and 9216, system jumbo MTU needs to be adjusted to appropriate value where interface can be configured with the same value.



Note You can change the system jumbo MTU size. When the value is changed, the Layer 2 interfaces that use the system jumbo MTU value, will automatically changes to the new system jumbo MTU value.

A Layer 3 interface, can be Layer 3 physical interface switch virtual interface (SVI), and subinterface, you can configure an MTU size between 576–9216 bytes.

Configuring the MTU Size

MTU is configured per interface, where the interface can be a Layer 2 or a Layer 3 interface. Every interface has default MTU of 1500 bytes. This value is called system default MTU. You can configure a Layer 2 interface, with a value of 9216 bytes, which is the default value of the system jumbo MTU. To allow an MTU value that is between 1500 and 9216, system jumbo MTU needs to be adjusted to appropriate value where interface can be configured with the same value.



Note You can change the system jumbo MTU size. When the value is changed, the Layer 2 interfaces that use the system jumbo MTU value, will automatically changes to the new system jumbo MTU value.

A Layer 3 interface, can be Layer 3 physical interface switch virtual interface (SVI), and subinterface, you can configure an MTU size between 576–9216 bytes.

Configuring the System Jumbo MTU Size

You can configure and use the system jumbo MTU for a Layer 2 interfaces MTU value. The system jumbo MTU must be specified as an even number between 1500 and 9216. The default value of system jumbo MTU is 9216 bytes.

SUMMARY STEPS

1. **configure terminal**
2. **system jumbomtu** *size*
3. **interface** *type slot/port*
4. **mtu** *size*
5. **exit**
6. **copy running-config startup-config**

DETAILED STEPS

	Command or Action	Purpose
Step 1	configure terminal Example: switch# configure terminal switch(config)#	Enters global configuration mode.
Step 2	system jumbo mtu size Example: switch(config)# system jumbo mtu 8000 switch(config)#	Specifies the system jumbo MTU size. Use an even number between 1500 and 9216.
Step 3	interface type slot/port Example: switch(config)# interface ethernet 2/1 switch(config-if)#	Specifies an interface to configure and enters interface configuration mode.
Step 4	mtu size Example: switch(config-if)# mtu 8000 switch(config-if)#	System jumbo MTU is added to a Layer 2 interface.
Step 5	exit Example: switch(config-if)# exit switch(config)#	Exits the interface mode.
Step 6	copy running-config startup-config Example: switch(config)# copy running-config startup-config	(Optional) Copies the running configuration to the startup configuration.

Example

This example shows how to configure the system jumbo MTU as 8000 bytes and how to change the MTU specification for a Layer 2 interface that was configured with the previous jumbo MTU size:

```
switch# configure terminal
switch(config)# system jumbo mtu 8000
switch(config)# interface ethernet 2/2
switch(config-if)# mtu 8000
```

Configuring the Bandwidth

You can configure the bandwidth for Ethernet interfaces. The physical layer uses an unchangeable bandwidth of 1G, 10G, or 40G, but you can configure a value of 1 to 100,000,000 KB for Level 3 protocols.

SUMMARY STEPS

1. **configure terminal**
2. **interface ethernet *slot/port***
3. **bandwidth *kbps***
4. **show interface ethernet *slot/port***
5. **exit**
6. **copy running-config startup-config**

DETAILED STEPS

	Command or Action	Purpose
Step 1	configure terminal Example: switch# configure terminal switch(config)#	Enters global configuration mode.
Step 2	interface ethernet <i>slot/port</i> Example: switch(config)# interface ethernet 3/1 switch(config-if)#	Specifies an Ethernet interface to configure, and enters interface configuration mode.
Step 3	bandwidth <i>kbps</i> Example: switch(config-if)# bandwidth 1000000 switch(config-if)#	Specifies the bandwidth as an informational-only value between 1 and 100,000,000.
Step 4	show interface ethernet <i>slot/port</i> Example: switch(config)# show interface ethernet 2/1	(Optional) Displays the interface status, which includes the bandwidth value.
Step 5	exit Example: switch(config-if)# exit switch(config)#	Exits the interface mode.
Step 6	copy running-config startup-config Example: switch(config)# copy running-config startup-config	(Optional) Copies the running configuration to the startup configuration.

Example

This example shows how to configure an informational value of 1,000,000 Kb for the Ethernet slot 3, port 1 interface bandwidth parameter:

```
switch# configure terminal
switch(config)# interface ethernet 3/1
```

```
switch(config-if) # bandwidth 1000000
switch(config-if) #
```

Configuring the Throughput Delay

You can configure the interface throughput delay for Ethernet interfaces. The actual delay time does not change, but you can set an informational value between 1 and 16777215, where the value represents the number of tens of microseconds.

SUMMARY STEPS

1. **configure terminal**
2. **interface ethernet *slot/port***
3. **delay *value***
4. **show interface ethernet *slot/port***
5. **exit**
6. **copy running-config startup-config**

DETAILED STEPS

	Command or Action	Purpose
Step 1	configure terminal Example: switch# configure terminal switch(config)#	Enters global configuration mode.
Step 2	interface ethernet <i>slot/port</i> Example: switch(config) # interface ethernet 3/1 switch(config-if) #	Specifies an Ethernet interface to configure, and enters interface configuration mode.
Step 3	delay <i>value</i> Example: switch(config-if) # delay 10000 switch(config-if) #	Specifies the delay time in tens of microseconds. You can set an informational value range between 1 and 16777215 tens of microseconds.
Step 4	show interface ethernet <i>slot/port</i> Example: switch(config) # show interface ethernet 3/1 switch(config-if) #	(Optional) Displays the interface status, which includes the throughput-delay time.
Step 5	exit Example: switch(config-if) # exit switch(config) #	Exits the interface mode.
Step 6	copy running-config startup-config Example:	(Optional) Copies the running configuration to the startup configuration.

	Command or Action	Purpose
	switch(config)# copy running-config startup-config	

Example

This example shows how to configure the throughput-delay time so that one interface is preferred over another. A lower delay value is preferred over a higher value. In this example, Ethernet 7/48 is preferred over 7/47. The default delay for 7/48 is less than the configured value on 7/47, which is set for the highest value (16777215):

```
switch# configure terminal
switch(config)# interface ethernet 7/47
switch(config-if)# delay 16777215
switch(config-if)# ip address 192.168.10.1/24
switch(config-if)# ip router eigrp 10
switch(config-if)# no shutdown
switch(config-if)# exit
switch(config)# interface ethernet 7/48
switch(config-if)# ip address 192.168.11.1/24
switch(config-if)# ip router eigrp 10
switch(config-if)# no shutdown
switch(config-if)#
```



Note You must first ensure the EIGRP feature is enabled by running the **feature eigrp** command.

Shutting Down and Activating the Interface

You can shut down and restart Ethernet or management interfaces. When you shut down interfaces, they become disabled and all monitoring displays show them as being down. This information is communicated to other network servers through all dynamic routing protocols. When the interfaces are shut down, the interface is not included in any routing updates. To activate the interface, you must restart the device.

SUMMARY STEPS

1. **configure terminal**
2. **interface** *interface*
3. **shutdown**
4. **show interface** *interface*
5. **no shutdown**
6. **show interface** *interface*
7. **exit**
8. **copy running-config startup-config**

DETAILED STEPS

	Command or Action	Purpose
Step 1	configure terminal Example: <pre>switch# configure terminal switch(config)#</pre>	Enters global configuration mode.
Step 2	interface interface Example: <pre>switch(config)# interface ethernet 2/1 switch(config-if)# switch(config)# interface mgmt0 switch(config-if)#</pre>	Specifies the interface that you are configuring. You can specify the interface type and identity. For an Ethernet port, use <i>ethernet slot/port</i> . For the management interface, use <i>mgmt0</i> . Examples: <ul style="list-style-type: none"> • The 1st example shows how to specify the slot 2, port 1 Ethernet interface. • The 2nd example shows how to specify the management interface.
Step 3	shutdown Example: <pre>switch(config-if)# shutdown switch(config-if)#</pre>	Disables the interface.
Step 4	show interface interface Example: <pre>switch(config-if)# show interface ethernet 2/1 switch(config-if)#</pre>	(Optional) Displays the interface status, which includes the administrative status.
Step 5	no shutdown Example: <pre>switch(config-if)# no shutdown switch(config-if)#</pre>	Reenables the interface.
Step 6	show interface interface Example: <pre>switch(config-if)# show interface ethernet 2/1 switch(config-if)#</pre>	(Optional) Displays the interface status, which includes the administrative status.
Step 7	exit Example: <pre>switch(config-if)# exit switch(config)#</pre>	Exits the interface mode.
Step 8	copy running-config startup-config Example: <pre>switch(config)# copy running-config startup-config</pre>	(Optional) Copies the running configuration to the startup configuration.

Example

This example shows how to change the administrative status for Ethernet port 3/1 from disabled to enabled:

```
switch# configure terminal
switch(config)# interface ethernet 3/1
switch(config-if)# shutdown
switch(config-if)# no shutdown
switch(config-if)#
```

Configuring the UDLD Mode

You can configure normal unidirectional link detection (UDLD) modes for Ethernet interfaces on devices configured to run UDLD.

Before you can enable the aggressive UDLD mode for an interface, you must make sure that UDLD is already enabled globally on the device and on the specified interfaces.



Note If the interface is a copper port, you must use the command `enable UDLD` to enable the UDLD. If the interface is a fiber port you need not explicitly enable UDLD on the interface. However if you attempt to enable UDLD on a fiber port using the `enable UDLD` command, you may get an error message indicating that is not a valid command.

The following table lists CLI details to enable and disable UDLD on different interfaces

Table 3: CLI Details to Enable or Disable UDLD on Different Interfaces

Description	Fiber port	Copper or Nonfiber port
Default setting	Enabled	Disabled
Enable UDLD command	no udld disable	udld enable
Disable UDLD command	udld disable	no udld enable

Before you begin

You must enable UDLD for the other linked port and its device.

SUMMARY STEPS

1. `configure terminal`
2. `[no] feature udld`
3. `udld message-time seconds`
4. `udld aggressive`
5. `interface ethernet slot/port`
6. `udld [enable | disable]`
7. `show udld [ethernet slot/port | global | neighbors]`

8. `exit`
9. `copy running-config startup-config`

DETAILED STEPS

	Command or Action	Purpose
Step 1	configure terminal Example: <pre>switch# configure terminal switch(config) #</pre>	Enters global configuration mode.
Step 2	[no] feature udld Example: <pre>switch(config) # feature udld switch(config) # switch(config) # no feature udld switch(config) #</pre>	Enables/Disables UDLD for the device.
Step 3	udld message-time <i>seconds</i> Example: <pre>switch(config) # udld message-time 30 switch(config) #</pre>	(Optional) Specifies the interval between sending UDLD messages. The range is from 7 to 90 seconds, and the default is 15 seconds.
Step 4	udld aggressive Example: <pre>switch(config) # udld aggressive switch(config) #</pre>	<p>Enables UDLD in aggressive mode by default on all fiber interfaces. Use the no form to disable aggressive mode UDLD on all fibers ports by default.</p> <p>Note Use the <code>udld aggressive</code> command to configure the ports to use a UDLD mode:</p> <ul style="list-style-type: none"> • To enable fiber interfaces for the aggressive mode, enter the udld aggressive command in the global command mode and all the fiber interfaces will be in aggressive UDLD mode. • To enable the copper interfaces for the aggressive mode, you must enter the udld aggressive command in the interface mode, specifying each interface you want in aggressive UDLD mode. <p>To use the aggressive UDLD mode, you must configure the interfaces on both ends of the link for the aggressive UDLD mode.</p>
Step 5	interface ethernet <i>slot/port</i> Example:	(Optional) Specifies an interface to configure, and enters interface configuration mode.

	Command or Action	Purpose
	switch(config)# interface ethernet 3/1 switch(config-if)#	
Step 6	udld [enable disable] Example: switch(config-if)# udld enable switch(config-if)#	Enables UDLD in normal mode by default on all fiber interfaces. Use the no form to disable normal mode UDLD on all fibers ports by default.
Step 7	show udld [ethernet slot/port global neighbors] Example: switch(config)# show udld switch(config)#	(Optional) Displays the UDLD status.
Step 8	exit Example: switch(config-if-range)# exit switch(config)#	Exits the interface mode.
Step 9	copy running-config startup-config Example: switch(config)# copy running-config startup-config	(Optional) Copies the running configuration to the startup configuration.

Example

This example shows how to enable the UDLD for the device:

```
switch# configure terminal
switch(config)# feature udld
switch(config)#
```

This example shows how to set the UDLD message interval to 30 seconds:

```
switch# configure terminal
switch(config)# feature udld
switch(config)# udld message-time 30
switch(config)#
```

This example shows how to disable UDLD for Ethernet port 3/1:

```
switch# configure terminal
switch(config)# interface ethernet 3/1
switch(config-if-range)# no udld enable
switch(config-if-range)# exit
```

This example shows how to disable UDLD for the device:

```
switch# configure terminal
switch(config)# no feature udld
switch(config)# exit
```

This example shows how to enable fiber interfaces for the aggressive UDLD mode:

```
switch# configure terminal
switch(config)# udld aggressive
```

This example shows how to enable the aggressive UDLD mode for the copper Ethernet interface3/1:

```
switch# configure terminal
switch(config)# interface ethernet 3
switch(config-if)# udld aggressive
```

This example shows how to check if aggressive mode is enabled.

```
switch# sh udld global

UDLD global configuration mode: enabled-aggressive
UDLD global message interval: 15
switch#
```

This example shows how to check if udld aggressive mode is operational for a given interface.

```
switch# sh udld ethernet 8/2

Interface Ethernet8/2
-----
Port enable administrative configuration setting: device-default
Port enable operational state: enabled-aggressive
Current bidirectional state: bidirectional
Current operational state: advertisement - Single neighbor detected
Message interval: 15
Timeout interval: 5
<>
```

Configuring Debounce Timers

You can enable the debounce timer for Ethernet ports by specifying a debounce time (in milliseconds) or disable the timer by specifying a debounce time of 0.



Note The link state of 10G and 100G ports may change repeatedly when connected to service provider network. As a part of *link reset* or *break-link* functionality, it is expected that the Tx power light on the SFP to change to N/A state, at an event of link state change.

However, to prevent this behavior during the link state change, you may increase the link debounce timer to start from 500ms and increase it in 500ms intervals until the link stabilizes. On the DWDM, UVN, and WAN network, it is recommended to disable automatic link suspension (ALS) whenever possible. ALS suspends the link on the WAN when the Nexus turn off the link.



Note The **link debounce time** and **link debounce link-up time** commands can only be applied to a physical Ethernet interface.

Use the **show interface debounce** command to display the debounce times for all Ethernet ports.

The **link debounce time** command is supported on 1G, 10G, 40G, 25G and 100G SFP/QSFP ports on the Cisco Nexus 3600 series switches.

SUMMARY STEPS

1. configure terminal

2. **interface ethernet** *slot/port*
3. **link debounce time** *time*

DETAILED STEPS

	Command or Action	Purpose
Step 1	configure terminal Example: <pre>switch# configure terminal switch(config)#</pre>	Enters global configuration mode.
Step 2	interface ethernet <i>slot/port</i> Example: <pre>switch(config)# interface ethernet 3/1 switch(config-if)#</pre>	Specifies an Ethernet interface to configure, and enters interface configuration mode.
Step 3	link debounce time <i>time</i> Example: <pre>switch(config-if)# link debounce time 1000 switch(config-if)#</pre>	Enables the debounce timer for the specified time (1 to 5000 milliseconds). If you specify 0 milliseconds, the debounce timer is disabled.

Example

- The following example enables the debounce timer and sets the debounce time to 1000 milliseconds for an Ethernet interface:

```
switch# configure terminal
switch(config)# interface ethernet 1/4
switch(config-if)# link debounce time 1000
```

- The following example disables the debounce timer for an Ethernet interface:

```
switch# configure terminal
switch(config)# interface ethernet 1/4
switch(config-if)# link debounce time 0
```

Configuring Port Profiles

Creating a Port Profile

You can create a port profile on the device. Each port profile must have a unique name across types and the network.



Note Port profile names can include only the following characters:

- a-z
- A-Z
- 0-9
- No special characters are allowed, except for the following:
 - .
 - -
 - _

SUMMARY STEPS

1. **configure terminal**
2. **port-profile** [type {ethernet | interface-vlan | port-channel}] *name*
3. **exit**
4. (Optional) **show port-profile**
5. (Optional) **copy running-config startup-config**

DETAILED STEPS

	Command or Action	Purpose
Step 1	configure terminal	Enters the global configuration mode.
Step 2	port-profile [type {ethernet interface-vlan port-channel}] <i>name</i>	Creates and names a port profile for the specified type of interface and enters the port-profile configuration mode.
Step 3	exit	Exits the port-profile configuration mode.
Step 4	(Optional) show port-profile	Displays the port-profile configuration.
Step 5	(Optional) copy running-config startup-config	Copies the running configuration to the startup configuration.

Example

This example shows how to create a port profile named test for ethernet interfaces:

```
switch# configure terminal
switch(config)# port-profile type ethernet test
switch(config-ppm)#
```

Entering Port-Profile Configuration Mode and Modifying a Port Profile

You can enter the port-profile configuration mode and modify a port profile. To modify the port profile, you must be in the port-profile configuration mode.

SUMMARY STEPS

1. **configure terminal**
2. **port-profile** [**type** {**ethernet** | **interface-vlan** | **port-channel**}] *name*
3. **exit**
4. (Optional) **show port-profile**
5. (Optional) **copy running-config startup-config**

DETAILED STEPS

	Command or Action	Purpose
Step 1	configure terminal	Enters the global configuration mode.
Step 2	port-profile [type { ethernet interface-vlan port-channel }] <i>name</i>	Enters the port-profile configuration mode for the specified port profile and allows you to add or remove configurations to the profile.
Step 3	exit	Exits the port-profile configuration mode.
Step 4	(Optional) show port-profile	Displays the port-profile configuration.
Step 5	(Optional) copy running-config startup-config	Copies the running configuration to the startup configuration.

Example

This example shows how to enter the port-profile configuration mode for the specified port profile and bring all the interfaces administratively up:

```
switch# configure terminal
switch(config)# port-profile type ethernet test
switch(config-ppm)# no shutdown
switch(config-ppm)#
```

Assigning a Port Profile to a Range of Interfaces

You can assign a port profile to an interface or to a range of interfaces. All the interfaces must be the same type.

SUMMARY STEPS

1. **configure terminal**
2. **interface** [**ethernet** *slot/port* | **interface-vlan** *vlan-id* | **port-channel** *number*]
3. **inherit port-profile** *name*
4. **exit**

5. (Optional) **show port-profile**
6. (Optional) **copy running-config startup-config**

DETAILED STEPS

	Command or Action	Purpose
Step 1	configure terminal	Enters the global configuration mode.
Step 2	interface [ethernet <i>slot/port</i> interface-vlan <i>vlan-id</i> port-channel <i>number</i>]	Selects the range of interfaces.
Step 3	inherit port-profile <i>name</i>	Assigns the specified port profile to the selected interfaces.
Step 4	exit	Exits the port-profile configuration mode.
Step 5	(Optional) show port-profile	Displays the port-profile configuration.
Step 6	(Optional) copy running-config startup-config	Copies the running configuration to the startup configuration.

Example

This example shows how to assign the port profile named adam to Ethernet interfaces 7/3 to 7/5, 10/2, and 11/20 to 11/25:

```
switch# configure terminal
switch(config)# interface ethernet7/3-5, ethernet10/2, ethernet11/20-25
switch(config-if)# inherit port-profile adam
switch(config-if)#
```

Enabling a Specific Port Profile

To apply the port-profile configurations to the interfaces, you must enable the specific port profile. You can configure and inherit a port profile onto a range of interfaces before you enable that port profile. You would then enable that port profile for the configurations to take effect on the specified interfaces.

If you inherit one or more port profiles onto an original port profile, only the last inherited port profile must be enabled; the system assumes that the underlying port profiles are enabled.

You must be in the port-profile configuration mode to enable or disable port profiles.

SUMMARY STEPS

1. **configure terminal**
2. **port-profile** [**type** {**ethernet** | **interface-vlan** | **port-channel**}] *name*
3. **state enabled**
4. **exit**
5. (Optional) **show port-profile**
6. (Optional) **copy running-config startup-config**

DETAILED STEPS

	Command or Action	Purpose
Step 1	<code>configure terminal</code>	Enters the global configuration mode.
Step 2	<code>port-profile [type {ethernet interface-vlan port-channel}] name</code>	Creates and names a port profile for the specified type of interface and enters the port-profile configuration mode.
Step 3	<code>state enabled</code>	Enables that port profile.
Step 4	<code>exit</code>	Exits the port-profile configuration mode.
Step 5	(Optional) <code>show port-profile</code>	Displays the port-profile configuration.
Step 6	(Optional) <code>copy running-config startup-config</code>	Copies the running configuration to the startup configuration.

Example

This example shows how to enter the port-profile configuration mode and enable the port profile:

```
switch# configure terminal
switch(config)# port-profile type ethernet test
switch(config-ppm)# state enabled
switch(config-ppm)#
```

Inheriting a Port Profile

You can inherit a port profile onto an existing port profile. The system supports four levels of inheritance.

SUMMARY STEPS

1. `configure terminal`
2. `port-profile name`
3. `inherit port-profile name`
4. `exit`
5. (Optional) `show port-profile`
6. (Optional) `copy running-config startup-config`

DETAILED STEPS

	Command or Action	Purpose
Step 1	<code>configure terminal</code>	Enters the global configuration mode.
Step 2	<code>port-profile name</code>	Enters the port-profile configuration mode for the specified port profile.
Step 3	<code>inherit port-profile name</code>	Inherits another port profile onto the existing one. The original port profile assumes all the configurations of the inherited port profile.

	Command or Action	Purpose
Step 4	exit	Exits the port-profile configuration mode.
Step 5	(Optional) show port-profile	Displays the port-profile configuration.
Step 6	(Optional) copy running-config startup-config	Copies the running configuration to the startup configuration.

Example

This example shows how to inherit the port profile named adam onto the port profile named test:

```
switch# configure terminal
switch(config)# port-profile test
switch(config-ppm)# inherit port-profile adam
switch(config-ppm)#
```

Removing a Port Profile from a Range of Interfaces

You can remove a port profile from some or all of the interfaces to which you have applied the profile. You do this configuration in the interfaces configuration mode.

SUMMARY STEPS

1. **configure terminal**
2. **interface** [ethernet *slot/port* | **interface-vlan** *vlan-id* | **port-channel** *number*]
3. **no inherit port-profile** *name*
4. **exit**
5. (Optional) **show port-profile**
6. (Optional) **copy running-config startup-config**

DETAILED STEPS

	Command or Action	Purpose
Step 1	configure terminal	Enters the global configuration mode.
Step 2	interface [ethernet <i>slot/port</i> interface-vlan <i>vlan-id</i> port-channel <i>number</i>]	Selects the range of interfaces.
Step 3	no inherit port-profile <i>name</i>	Un-assigns the specified port profile to the selected interfaces.
Step 4	exit	Exits the port-profile configuration mode.
Step 5	(Optional) show port-profile	Displays the port-profile configuration.
Step 6	(Optional) copy running-config startup-config	Copies the running configuration to the startup configuration.

Example

This example shows how to unassign the port profile named adam to Ethernet interfaces 7/3 to 7/5, 10/2, and 11/20 to 11/25:

```
switch# configure terminal
switch(config)# interface ethernet 7/3-5, 10/2, 11/20-25
switch(config-if)# no inherit port-profile adam
switch(config-if)#
```

Removing an Inherited Port Profile

You can remove an inherited port profile. You do this configuration in the port-profile mode.

SUMMARY STEPS

1. **configure terminal**
2. **port-profile** *name*
3. **no inherit port-profile** *name*
4. **exit**
5. (Optional) **show port-profile**
6. (Optional) **copy running-config startup-config**

DETAILED STEPS

	Command or Action	Purpose
Step 1	configure terminal	Enters the global configuration mode.
Step 2	port-profile <i>name</i>	Enters the port-profile configuration mode for the specified port profile.
Step 3	no inherit port-profile <i>name</i>	Removes an inherited port profile from this port profile.
Step 4	exit	Exits the port-profile configuration mode.
Step 5	(Optional) show port-profile	Displays the port-profile configuration.
Step 6	(Optional) copy running-config startup-config	Copies the running configuration to the startup configuration.

Example

This example shows how to remove the inherited port profile named adam from the port profile named test:

```
switch# configure terminal
switch(config)# port-profile test
switch(config-ppm)# no inherit port-profile adam
switch(config-ppm)#
```

Configuring DWDM

You can configure DWDM to operate at one of the 96 possible wavelengths available.

SUMMARY STEPS

1. **configure terminal**
2. **interface *interface***
3. **itu channel 1-96**
4. **exit**
5. **show run interface**
6. **show *itu channel all***

DETAILED STEPS

	Command or Action	Purpose
Step 1	configure terminal Example: switch# configure terminal switch(config)#	Enters global configuration mode.
Step 2	interface <i>interface</i> Example: config)# interface <type slot/port> switch(config-if)#	Enter interface configuration mode.
Step 3	itu channel 1-96 Example: config)# interface <type slot/port> switch(config-if)# itu channel ?	Specify the itu channel value, and enter the configuration.
Step 4	exit Example: switch(config-if)# exit switch(config)#	Exits the interface mode.
Step 5	show run interface Example: switch(config)# show run interface <type slot/port> switch(config)#	Displays the value of itu channel.
Step 6	show <i>itu channel all</i> Example: switch(config)# show itu channel [<> all] switch# sh itu channel ?	Displays the mapping of all itu channel, wavelength and frequency.

Configuring 25G Autonegotiation

Guidelines and Limitations for 25G Autonegotiation

- Beginning with Cisco NX-OS Release 9.2(1), autonegotiation on native 25G ports with copper cables is supported on Cisco Nexus 3600 Series platform switches.
- Autonegotiation is not supported on 25G breakout ports.
- Autonegotiation is not supported when Cisco Nexus 3600 switch is connected to N9K-C93108TC-FX3P switch.
- When connecting a Cisco Nexus 3600 to a 9300-FX/FX2 switch using an SFP-H25GB-CU4M or SFP-H25GB-CU5M cable, it is necessary to manually configure the FEC mode to **rs-ieee** on both devices. Without this manual configuration, the connection may fail to autonegotiate and establish a link due to FEC mismatch.

Enabling FEC Manually on an Interface

To enable FEC manually on an interface, follow these steps:

SUMMARY STEPS

1. **configure terminal**
2. **interface ethernet *port number***
3. **fec { auto | rs-fec | rs-ieee | fc-fec }**

DETAILED STEPS

	Command or Action	Purpose
Step 1	configure terminal Example: <pre>switch# configure terminal switch(config)#</pre>	Enters global configuration mode.
Step 2	interface ethernet <i>port number</i> Example: <pre>switch# int e1/7 switch(config-if)#</pre>	Selects the interface and enters interface mode.
Step 3	fec { auto rs-fec rs-ieee fc-fec } Example: <pre>switch(config-if)# fec auto switch(config-if)#</pre>	Enables the specified FEC type on the selected interface.

Enabling Autonegotiation

You can enable autonegotiation using the *negotiate auto* command. To enable autonegotiation, follow these steps:

SUMMARY STEPS

1. **configure terminal**
2. **interface ethernet *port number***
3. **negotiate auto *port speed***

DETAILED STEPS

	Command or Action	Purpose
Step 1	configure terminal Example: <pre>switch# configure terminal switch(config)#</pre>	Enters global configuration mode.
Step 2	interface ethernet <i>port number</i> Example: <pre>switch# int e1/7 switch(config-if)#</pre>	Selects the interface and enters interface mode.
Step 3	negotiate auto <i>port speed</i> Example: <pre>switch(config-if)# negotiate auto 25000 switch(config-if)#</pre>	Enables autonegotiation on the selected interface. Note You must apply this command on interfaces at both sides of the 25G native link.

This example shows how to enable autonegotiation on a specified interface:

Example

```
switch# sh int e1/7 st
-----
Port          Name          Status      Vlan      Duplex  Speed  Type
-----
Eth1/7        --            connected  routed    full    25G    SFP-H25GB-CU1M
switch# conf
switch(config)# int e1/7
switch(config-if)# negotiate auto 25000
```

Disabling Autonegotiation

You can disable autonegotiation using the *no negotiate auto* command. To disable autonegotiation, follow these steps:

SUMMARY STEPS

1. **configure terminal**
2. **interface ethernet *port number***
3. **no negotiate auto *port speed***

DETAILED STEPS

	Command or Action	Purpose
Step 1	configure terminal Example: <pre>switch# configure terminal switch(config)#</pre>	Enters global configuration mode.
Step 2	interface ethernet <i>port number</i> Example: <pre>switch# int e1/7 switch(config-if)#</pre>	Selects the interface and enters interface mode.
Step 3	no negotiate auto <i>port speed</i> Example: <pre>switch(config-if)# no negotiate auto 25000 switch(config-if)#</pre>	Disables autonegotiation on the selected interface. Note You must apply this command on interfaces at both sides of the link.

This example shows how to disable autonegotiation on a specified interface.

Example

```
switch# sh int e1/7 st
-----
Port          Name          Status      Vlan      Duplex  Speed  Type
-----
Eth1/7       --            connected   routed    full    25G    SFP-H25GB-CU1M
switch# conf
switch(config)# int e1/7
switch(config-if)# no negotiate auto 25000
```

Verifying the Basic Interface Parameters

You can verify the basic interface parameters by displaying their values. You can also clear the counters listed when you display the parameter values.

To display basic interface configuration information, perform one of the following tasks:

Command	Purpose
show cdp all	Displays the CDP status.
show interface <i>interface</i>	Displays the configured states of one or all interfaces.
show interface brief	Displays a table of interface states.
show interface status err-disabled	Displays information about error-disabled interfaces.

Command	Purpose
<code>show udld interface</code>	Displays the UDLD status for the current interface or all interfaces.
<code>show udld global</code>	Displays the UDLD status for the current device.
<code>show interface fec</code>	Displays the FEC status of all interfaces.

Monitoring the Interface Counters

You can display and clear interface counters using Cisco NX-OS.

Displaying Interface Statistics

You can set up to three sampling intervals for statistics collections on interfaces.

SUMMARY STEPS

1. `configure terminal`
2. `interface ether slot/port`
3. `load-interval counters [1 | 2 | 3] seconds`
4. `show interface interface`
5. `exit`
6. `copy running-config startup-config`

DETAILED STEPS

	Command or Action	Purpose
Step 1	configure terminal Example: <pre>switch# configure terminal switch(config)#</pre>	Enters global configuration mode.
Step 2	interface ether slot/port Example: <pre>switch(config)# interface ether 4/1 switch(config)#</pre>	Specifies interface.
Step 3	load-interval counters [1 2 3] seconds Example: <pre>switch(config)# load-interval counters 1 100 switch(config)#</pre>	Sets up to three sampling intervals to collect bit-rate and packet-rate statistics. The default values for each counter is as follows: 1—30 seconds (60 seconds for VLAN) 2—300 seconds 3—not configured

	Command or Action	Purpose
Step 4	show interface <i>interface</i> Example: <pre>switch(config)# show interface ethernet 2/2 switch#</pre>	(Optional) Displays the interface status, which includes the counters.
Step 5	exit Example: <pre>switch(config-if-range)# exit switch(config)#</pre>	Exits the interface mode.
Step 6	copy running-config startup-config Example: <pre>switch(config)# copy running-config startup-config</pre>	(Optional) Copies the running configuration to the startup configuration.

Example

This example shows how to set the three sample intervals for the Ethernet port 3/1:

```
switch# configure terminal
switch(config)# interface ethernet 3/1
switch(config-if)# load-interval counter 1 60
switch(config-if)# load-interval counter 2 135
switch(config-if)# load-interval counter 3 225
switch(config-if)#
```

Clearing Interface Counters

You can clear the Ethernet and management interface counters by using the **clear counters interface** command. You can perform this task from the configuration mode or interface configuration mode.

SUMMARY STEPS

1. **clear counters interface** [**all** | **ethernet** *slot/port* | **loopback** *number* | **mgmt** *number* | **port channel** *channel-number*]
2. **show interface** *interface*
3. **show interface** [**ethernet** *slot/port* | **port channel** *channel-number*] **counters**

DETAILED STEPS

	Command or Action	Purpose
Step 1	clear counters interface [all ethernet <i>slot/port</i> loopback <i>number</i> mgmt <i>number</i> port channel <i>channel-number</i>] Example: <pre>switch# clear counters ethernet 2/1 switch#</pre>	Clears the interface counters.

	Command or Action	Purpose
Step 2	show interface <i>interface</i> Example: <pre>switch# show interface ethernet 2/1 switch#</pre>	(Optional) Displays the interface status.
Step 3	show interface [ethernet <i>slot/port</i> port channel <i>channel-number</i>] counters Example: <pre>switch# show interface ethernet 2/1 counters switch#</pre>	(Optional) Displays the interface counters.

Example

This example shows how to clear the counters on Ethernet port 5/5:

```
switch# clear counters interface ethernet 5/5
switch#
```