



Installing the Cisco MDS 9700 Series Switches

This chapter describes how to install the Cisco MDS 9700 Series Multilayer Director switches and its components. This chapter includes the following topics:

- [Preparing for Installation, on page 1](#)
- [Attaching Bottom-Support Rails to a Two-Post Rack, on page 5](#)
- [Attaching Bottom-Support Rails to a Four-Post Rack, on page 6](#)
- [System Grounding, on page 25](#)

Preparing for Installation



Note Before you install, operate, or service the system, read the Regulatory Compliance and Safety Information for the Cisco MDS 9000 Family for important safety information.



Warning This warning symbol indicates danger. You are in a situation that could cause physical injury. Before you work on any equipment, be aware of the hazards involved with electrical circuitry and be familiar with standard practices for preventing accidents. Use the statement number provided at the end of each warning to locate its translation in the translated safety warnings that accompanied this device. Statement 1071

SAVE THESE INSTRUCTIONS



Warning This unit is intended for installation in restricted access areas. A restricted access area can be accessed only through the use of a special tool, lock and key, or other means of security. Statement 1017



Warning Only trained and qualified personnel should be allowed to install, replace, or service this equipment. Statement 1030



Warning A readily accessible two-poled disconnect device must be incorporated in the fixed wiring. Statement 1022

This section provides the following topics:

Unpacking and Inspecting the Switch

Before you install a new chassis, you need to unpack and inspect it to be sure that you have all the items that you have ordered and verify that the switch was not damaged during the shipment. If anything is damaged or missing, contact your customer representative immediately.



Caution We recommend that you use a mechanical lift when the chassis is being moved or lifted. Fully loaded, Cisco MDS 9706 chassis can weigh up to 325 lb (147.5 kg), Cisco MDS 9710 chassis can weigh up to 449.5 lb (203.8 kg), and Cisco MDS 9718 chassis can weigh up to 923 lb (419 kg).



Caution When handling switch components, wear an ESD strap and handle modules by the carrier edges only. An ESD socket is provided on the chassis. For the ESD socket to be effective, the chassis must be grounded either through the power cable, the chassis ground, or metal-to-metal contact with a grounded rack.



Tip Keep the shipping container for use when moving or shipping the chassis in the future. The shipping carton can be flattened and stored with the pallet.



Note If you purchased this product through a Cisco reseller, contact the reseller directly for technical support. If you purchased this product directly from Cisco Systems, contact Cisco Technical Support at this URL: http://www.cisco.com/en/US/support/tsd_cisco_worldwide_contacts.html.



Note The switch is thoroughly inspected before shipment. If any damage occurred during transportation or any items are missing, contact your customer service representative immediately.

To inspect the shipment, follow these steps:

Step 1 Compare the shipment to the equipment list provided by your customer service representative and ensure that you have received all items, including the following:

- 1 or 2 supervisor modules
- 1 to 4, 8, or 16 switching modules depending on the Cisco MDS 9700 Series switch
- Up to six crossbar fabric switching modules

- 3 fan modules
- 1 to 4, 8, or 16 power supplies depending on the Cisco MDS 9700 Series switch
- Grounding lug kit
- Mounting kit
- ESD wrist strap
- Cables and connectors
- Cable management frames
 - Left and right side frames
 - Top frame
 - M4 x 12 mm flat-head Phillips screws (12)
 - Front door (1)
 - M3X8 mm pan-head screws (2)
- Front door kit optional

Step 2 Check for damage and report any discrepancies or damage to your customer service representative. Keep the following information ready:

- Invoice number of shipper (see packing slip)
- Model and serial number of the damaged unit
- Description of damage
- Effect of damage on the installation

Required Equipments

You need the following items before beginning the installation:

- Number 1 and number 2 Phillips screwdrivers with torque capability
- 3/16-inch flat-blade screwdriver
- Tape measure and level
- ESD wrist strap or other grounding device
- Antistatic mat or antistatic foam
- Torque wrench and socket for the DC power supply lug nuts
- In addition to the grounding items provided in the accessory kit, you need the following items:

- Grounding cable (6 AWG recommended), sized according to local and national installation requirements; the required length depends on the proximity of the Cisco MDS 9700 Series switch to proper grounding facilities.
- Crimping tool large enough to accommodate girth of the DC lug
- Wire-stripping tool

For the Cisco MDS 9700 Series, you need a mechanical lift to handle the weight of the fully-loaded chassis.

Installation Guidelines

Follow these guidelines when installing a Cisco MDS 9700 Series chassis.

- Plan your site configuration and prepare the site before installing the chassis. We recommend that you use the site planning tasks listed in [Appendix 8, “Site Planning and Maintenance Records.”](#)
- Ensure that there is adequate space around the switch to allow for servicing the switch and for adequate air flow. Air flow requirements are listed in [Appendix 6, “Technical Specifications”](#).
- Ensure that the air-conditioning meets the heat dissipation requirements listed in [Appendix 6, “Technical Specifications.”](#)
- Ensure that the rack meets the requirements listed in [Appendix 2, “Rack Requirements.”](#)
- Ensure that the site power meets the power requirements listed in [Appendix 6, “Technical Specifications.”](#) You can use an uninterruptible power supply (UPS) to protect against power failures.



Caution Avoid UPS types that use ferroresonant technology. These UPS types can become unstable with systems such as the Cisco MDS 9000 Family, which can have substantial current draw fluctuations because of fluctuating data traffic patterns.

- Ensure that circuits are sized according to local and national codes. For North America:
 - The 3000-W AC power supplies require a 20-A circuit.

If you are using 200/240 VAC power sources in North America, the circuits must be protected by two-pole circuit breakers.



Caution To prevent loss of input power, ensure that the total maximum loads on the circuits supplying power are within the current ratings of the wiring and breakers.

- Record your installation and configuration information as you work. See [Appendix 8, “Site Planning and Maintenance Records.”](#)
- Use the following screw torques when installing the switch:
 - Captive screws: 4 in-lb
 - M3 screws: 4 in-lb
 - M4 screws: 12 in-lb

- M6 screws: 20 in-lb
- 12-24 screws: 30 in-lb
- 10-20 screws: 22 in-lb

Attaching Bottom-Support Rails to a Two-Post Rack

The bottom-support rails support the weight of the switch chassis in the rack or cabinet. To maximize the stability of the rack, you must attach these rails at the lowest possible rack unit (RU).



Note To prevent bodily injury when mounting or servicing this unit in a rack, you must take special precautions to ensure that the system remains stable. The following guidelines are provided to ensure your safety:

- This unit should be mounted at the bottom of the rack if it is the only unit in the rack.
- When mounting this unit in a partially filled rack, load the rack from the bottom to the top with the heaviest component at the bottom of the rack.
- If the rack is provided with stabilizing devices, install the stabilizers before mounting or servicing the unit in the rack.

Before you begin

Before you can install the bottom support rails for the chassis, you must do the following:

- Verify that a two-post rack is installed and secured to the concrete sub floor (see “Installing a Rack or Cabinet”).
- If any other devices are stored in the rack or cabinet, verify that they are located below where you plan to install the switch. Also, verify that lighter devices in the same rack are located above where you plan to install this switch.
- Verify that the two-post bottom-support rails kit was ordered and shipped with the chassis.

Statement 1006

-
- Step 1** Position one of the two bottom-support rails at the lowest possible RU in the rack or cabinet. Be sure there is at least 9 RU of vertical space above the rails to install the chassis.
- Step 2** Use a manual Phillips torque screwdriver to attach the bottom-support rail to the rack using four M6 x 19 mm or 12-24 x 3/4 inch screws and tighten each screw to 40 in. lbs (4.5 N.m) of torque.

Figure 1: Attaching Bottom-Support Rails to a Rack

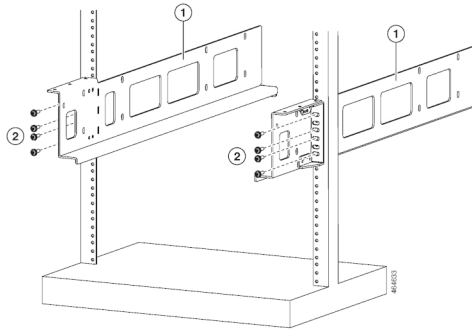

1	Adjustable bottom-support rails
2	M6 x 19 mm (or 12-24 x 3/4 in.) Phillips screws 3(6 to 8 per rail)

Step 3 Repeat Steps 1 and 2 to attach the other bottom-support rail to the rack.

Note Make sure that the two bottom-support rails are level with one another. If they are not level, adjust the higher rail down to the level of the lower rail.

When the bottom-support rails are installed at the lowest possible RU and are level, you are ready to install the chassis in the rack or cabinet.

Attaching Bottom-Support Rails to a Four-Post Rack

The bottom-support rails support the weight of the switch chassis in the rack or cabinet. To maximize the stability of the rack, you must attach these rails at the lowest possible rack unit (RU).



Note To prevent bodily injury when mounting or servicing this unit in a rack, you must take special precautions to ensure that the system remains stable. The following guidelines are provided to ensure your safety:

- This unit should be mounted at the bottom of the rack if it is the only unit in the rack.
- When mounting this unit in a partially filled rack, load the rack from the bottom to the top with the heaviest component at the bottom of the rack.
- If the rack is provided with stabilizing devices, install the stabilizers before mounting or servicing the unit in the rack.

Statement 1006

Before you begin

Before you can install the bottom support rails for the chassis, you must do the following:

- Verify that a four-post rack or cabinet is installed and secured to the concrete subfloor (see “[Rack and Cabinet Requirements](#)”).
- If any other devices are stored in the rack or cabinet, verify that they are located below where you plan to install the switch. Also, verify that lighter devices in the same rack are located above where you plan to install this switch.
- Verify that the bottom-support rails kit is included in the switch accessory kit (Unpack and inspect the chassis shipment for completeness and damage).

Step 1

Position one of the two adjustable bottom-support rails at the lowest possible RU in the rack or cabinet and adjust the length of the rail so that it stretches from the outer edges of the front and rear vertical mounting rails. Be sure there is at least 9 RU of vertical space above the rails to install the chassis.

You can expand the rail so that its mounting brackets are spaced between 24 to 32 inches (61.0 to 81.3 cm).

Figure 2: Positioning Bottom-Support Rail - Cisco MDS 9710 Chassis

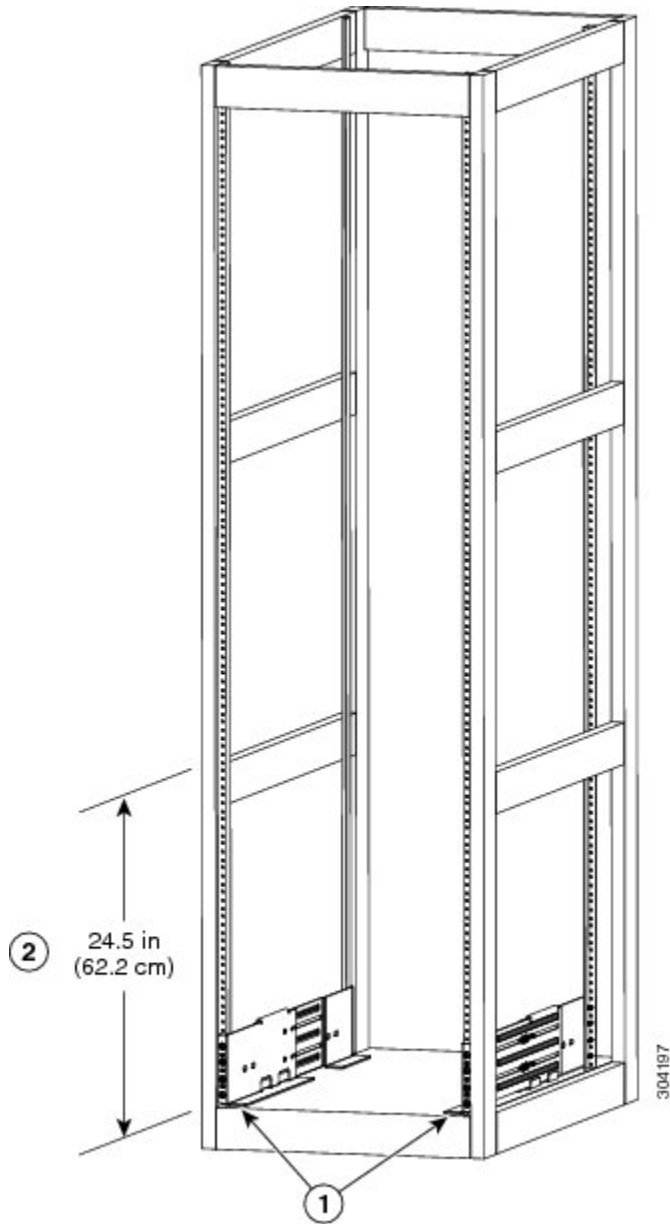

1	Position two bottom-support rails at the lowest RU on the rack.
2	Allow at least 24.5 inches (62.2 cm) (14 RU) for each chassis.

Figure 3: Positioning Bottom-Support Rail - Cisco MDS 9718 Chassis

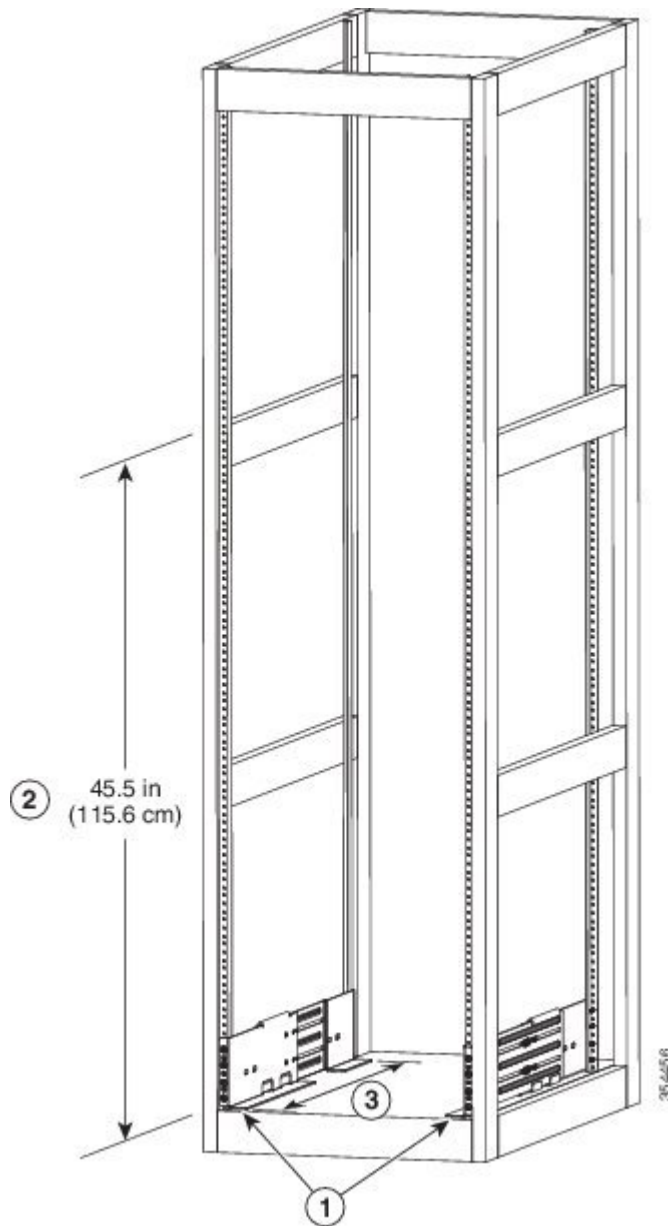

1	Position two bottom-support rails at the lowest RU on the rack.
2	Allow at least 45.5 inches (115.6 cm) (26 RU) for each chassis.

Step 2

Use a manual Phillips torque screwdriver to attach the bottom-support rail to the rack using at least three or four M6 x 19 mm or 12-24 x 3/4 inch screws for each end of the rail (using a total of 6 to 8 screws for the rail as shown [Figure 3-4](#)) and tighten each screw to 40 in. lbs (4.5 N.m) of torque.

Figure 4: Attaching Bottom-Support Rails to a Rack - Cisco MDS 9710 Chassis

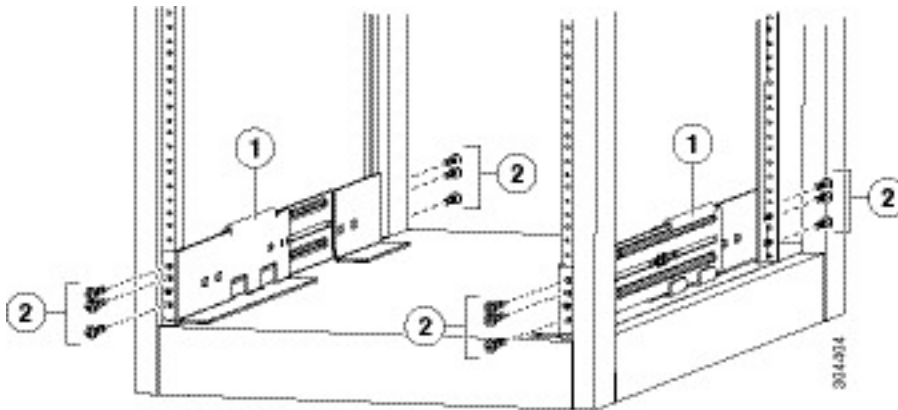

1	Adjustable bottom-support rails (2)
2	M6 x 19 mm (or 12-24 x 3/4 in.) Phillips screws (6 to 8 per rail).

Figure 5: Attaching Bottom-Support Rails to a Rack - Cisco MDS 9718 Chassis

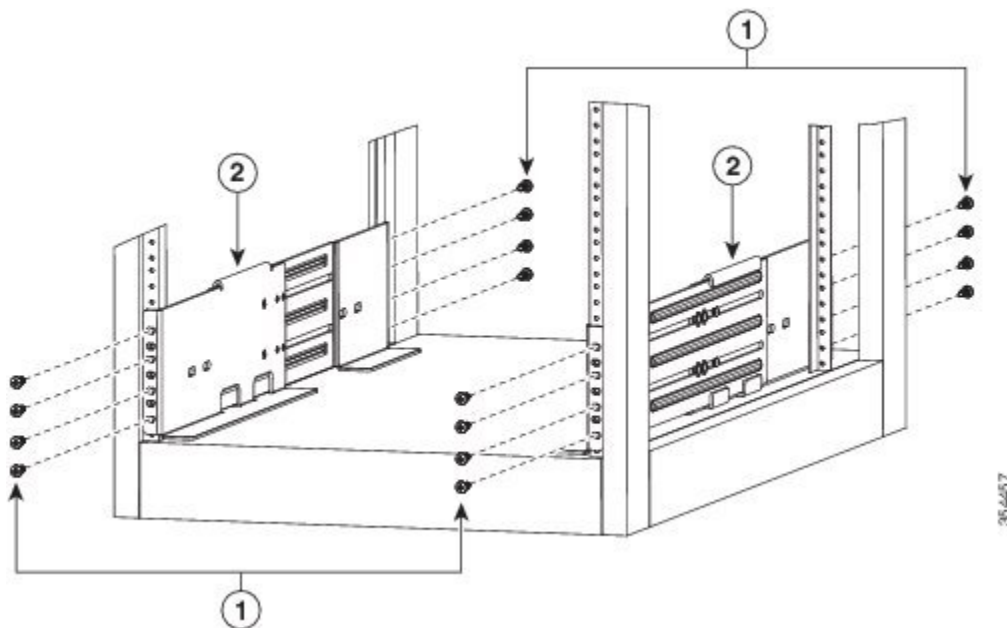

1	M6 x 19 mm (or 12-24 x 3/4 in.) Phillips screws (8 per rail)
2	Adjustable bottom-support rails (2)

Note At least three of the screw holes on each end of the bottom-support rail align to the mounting rail. Use at least three screws (four if possible) on each end of each bottom support rail.

Step 3 Repeat Step 1 and Step 2 to attach the other bottom-support rail to the rack. The other rail/bracket need to be flipped 180 degrees and installed to the other side of the rack because both the left and right sides are the same rail/bracket.

Note Make sure that the two bottom-support rails are level with one another. If they are not level, adjust the higher rail down to the level of the lower rail.

When the bottom-support rails are installed at the lowest possible RU and are level, you are ready to install the chassis in the rack or cabinet.

Installing the Cisco MDS 9706 Chassis in a Two-Post Rack

To Install MDS 9706 Chassis in a Two-Post Rack, perform the following steps:

Before you begin

- Verify that the chassis shipment is complete and undamaged.
- Verify that a two-post rack is installed and secured to the subfloor.



Warning Stability hazard. The rack stabilizing mechanism must be in place, or the rack must be bolted to the floor before you slide the unit out for servicing. Failure to stabilize the rack can cause the rack to tip over. Statement 1048

- Verify that the bottom-support rails have been attached to the lowest possible RU in the rack or cabinet and there is 9 RU (15.75 inches [40.0 cm]) of space above the rails to install the chassis.
- If there are other devices in the rack, verify that the devices that are heavier than this chassis are installed below where you are going to install the chassis and lighter devices are installed above where you are going to install the chassis.
- Verify that the data center ground is accessible where you are installing the chassis.
- Verify that you have the following tools and equipments:
 - Mechanical lift capable of lifting the full weight of the chassis and its installed modules



Note Fully loaded, the Cisco MDS 9706 chassis can weigh up to 325 lb (147.5 kg). You can lighten the chassis for easier moving by removing its power supplies, fan modules, and fabric modules. To determine the full weight of the chassis and the appropriate weight rating for the mechanical lift, see [Appendix 6, “Technical Specifications”](#).



Caution You must use a mechanical lift or floor jack to elevate a switch weighing over 120 pounds (55 kg).

- Manual Phillips-head torque screwdriver



Note You should also have at least two persons to push the chassis when you slide it onto the rack.



Note To prevent bodily injury when mounting or servicing this unit in a rack, you must take special precautions to ensure that the system remains stable. The following guidelines are provided to ensure your safety:

- This unit should be mounted at the bottom of the rack if it is the only unit in the rack.
 - When mounting this unit in a partially filled rack, load the rack from the bottom to the top with the heaviest component at the bottom of the rack.
 - If the rack is provided with stabilizing devices, install the stabilizers before mounting or servicing the unit in the rack.
-

Step 1

If you need to make the chassis as light as possible for moving, you can optionally remove the fabric modules, fan modules, and power supplies.

a) To remove a power supply, follow these steps:

1. Push and hold the release handle on the power supply to the left.
2. Pull the power supply about two inches (about 5 cm) out of the chassis.
3. Place one hand under the power supply to support its weight and pull the power supply out of the chassis.
4. Place the power supply on an antistatic surface.

b) To remove a fan module, follow these steps:

1. Unscrew the four captive screws on the front of the fan module (one captive screw in each corner of the front of the fan module).
2. Hold both handles on the fan module with both of your hands and pull the fan module out of the chassis.
3. Place the fan module on an antistatic surface.

c) To remove a fabric module, follow these steps:

Note Before you can remove a fabric module, you must remove the fan module that is installed in front of it.

1. Press the lever eject button found in the middle of the front of the module.
2. Rotate both of the levers away from the fabric module.
3. When the other end of each lever is no longer holding onto the chassis, pull the two levers to slide the module a couple inches out of the chassis.

4. Rotate the two levers back to the fabric module. Each lever will click when locked in place.
5. Place one hand on the front of the module and place your other hand under the module to support its weight.
6. Slide the module out of the chassis and place the module on an antistatic surface.

Step 2 Load the chassis onto a mechanical lift or floor jack as follows:

- a. Position the mechanical lift next to the shipping pallet that holds the chassis.
- b. Elevate the lift platform to the level of the bottom of the chassis (or no more than 1/4 inch [0.635 cm] below the bottom of the chassis).
- c. Use two persons to slide the chassis fully onto the lift so that the side of the chassis touches or is close to the vertical rails on the lift. Make sure that the front and rear of the chassis are unobstructed so you can easily push the chassis into the rack.

Warning To prevent personal injury or damage to the chassis, never attempt to lift or tilt the chassis using the handles on modules (such as power supplies, fans, or cards); these types of handles are not designed to support the weight of the unit. Statement 1032

Caution To lift the chassis, use a mechanical lift. Do not use the handles on the side of the chassis (the handles are not rated for lifting over 200 pounds [91 kg]). Use the side handles for only repositioning the chassis after it is already on the mechanical lift or in the rack or cabinet.

Step 3 Use the mechanical lift to move and align the rear of the chassis to the front of the rack or cabinet. Make sure that the bottom of the chassis is elevated to the height of the bottom-support rails or no more than 1/4 inch (0.6 cm) above the rails.

Step 4 Push the chassis halfway onto the rack or cabinet.

Use two persons to push the chassis onto the bottom-support rails. Push the lower half of the front side of the chassis so that the back side enters the rack first, and push until the chassis is halfway onto the rack (see the following figure). Ensure that the chassis does not get caught on any of the expansion edges of the bottom-support rail.

Figure 6: Moving a Chassis onto a Rack or Cabinet - Cisco MDS 9706 Chassis

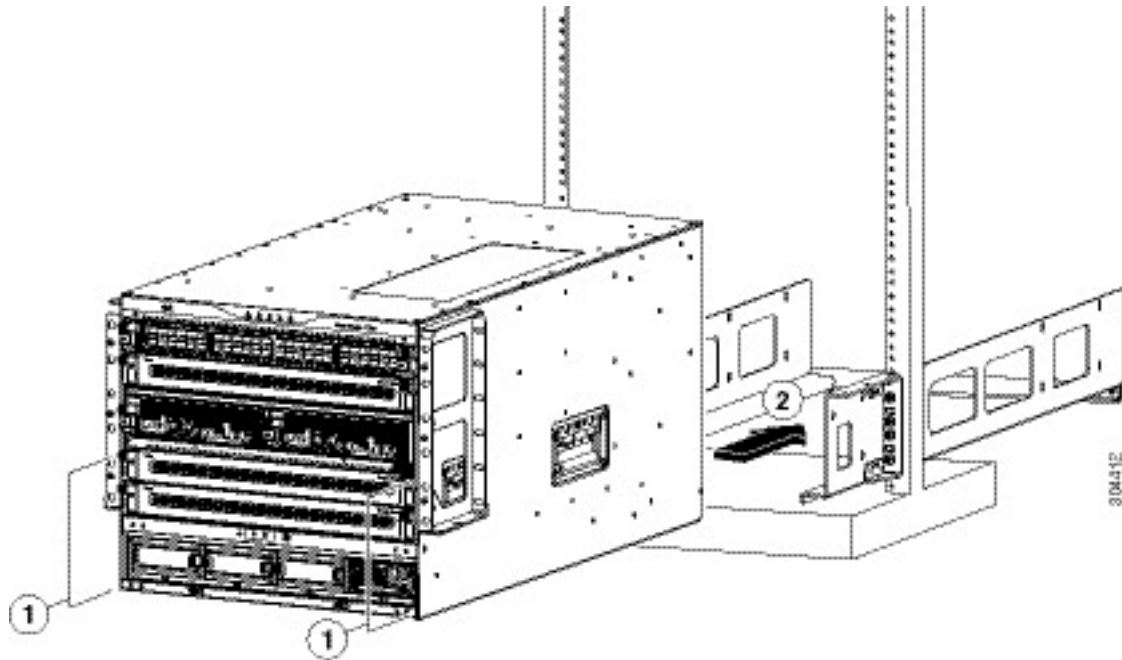

1	Push the sides of the lower half of the front side of the chassis.	2	Push the chassis into the rack until its mounting bracket touches the vertical mounting rails on the rack.
---	--	---	--

Tip To adjust the placement of the chassis on the bottom-support rails, you can use the handles on the sides of the chassis.

Step 5 If the mechanical lift is raised above the height of the bottom-support rails, gently lower it to the level of the rails or no more than 1/4 inch (0.6 cm) below the rails.

This action helps to prevent the bottom of the chassis from getting caught on the bottom expansion edges of the bottom-support rails.

Step 6 Push the chassis all the way onto the rack so that the vertical mounting brackets on the chassis come in contact with the vertical mounting rails on the rack.

Step 7 Use seven M6 x 19 mm or 24 x 3/4-inch screws to attach each of the two vertical mounting brackets on the chassis to the two vertical mounting rails on the rack (total of 14 screws). See the following figure.

Figure 7: Attaching the Chassis to the Rack

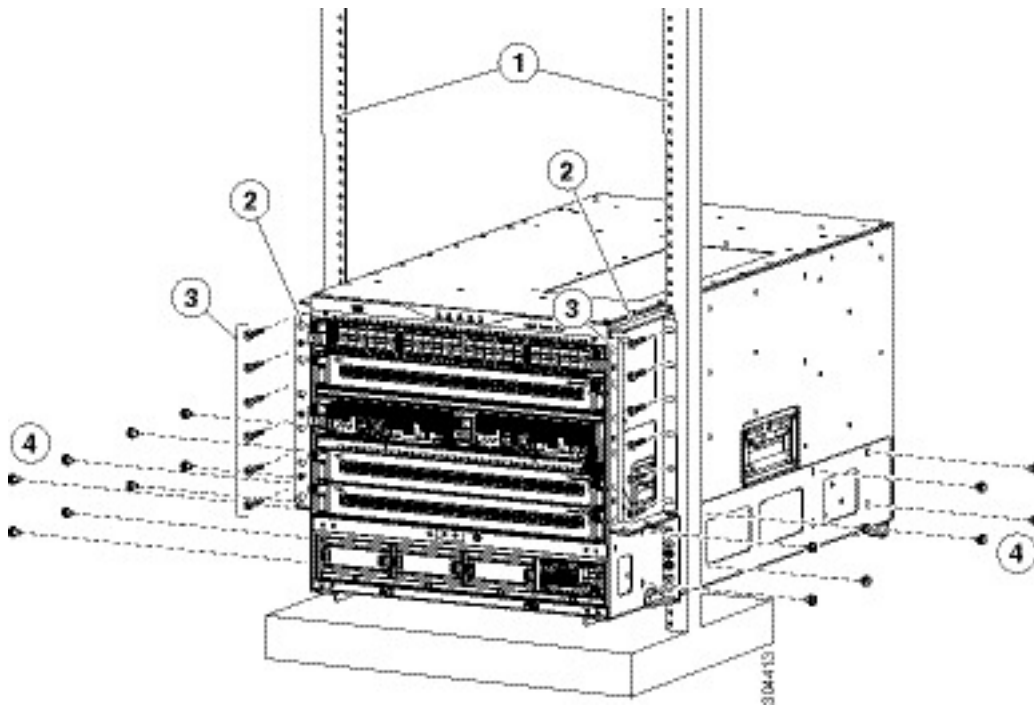

1	Vertical mounting rails on the rack	3	Six M6 x 19 mm or 10-24 x 3/4 in. Phillips screws used to attach each side bracket to a front mounting rail (use a total of 12 screws)
2	Mounting brackets for two-post racks	4	Eight M6 x 10 mm screws used to attach each bottom support rail to the chassis (use a total of 16 screws for both rails)

Step 8 Use eight M6 x 10 mm screws to attach the bottom-support rails to the chassis (use a total of 16 screws for both bottom support rails). See previous image.

Step 9 If you removed any fabric modules before moving the chassis, replace each one in the chassis as follows:

- a. Holding the front of the fabric module (the side with the LEDs), turn the module so that the front side is vertical.

Note The top of the module has an alignment bracket running from the rear to the front. The electrical connectors will be at the bottom.
- b. Align the rear of the fabric module to an open fabric slot and insert the bracket on top of the module into the track at the top of the slot.

Note If there are only three fabric modules to install, install them in fabric slots 1, 3, and 5, and be sure that there are blank filler plates installed in the open slots.
- c. Slide the module part way into the slot.
- d. Press the ejector button on the front of the module, to release the levers from the front of the module.

- e. Rotate the levers away from the front of the module and hold them while sliding the module all the way into the slot.
- f. Simultaneously rotate both levers to the front of the module. They click when locked to the front of the module.

Step 10 If you have removed any fan modules before moving the chassis, reinstall each one in the chassis as follows:

- a. Holding each of the two handles on the fan module with your two hands, align the fan module to an open fan module slot.

Note The two alignment brackets on top of the fan module should align to two tracks at the top of the slot.

- b. Slide the fan module into the slot until the front of the fan module comes in contact with the rear of the chassis.

Note The two alignment pins on the fan module (on the top and one on the bottom) should go into holes in the chassis and the four captive screws on the fan module should align to screw holes in the chassis.

- c. Screw in the four captive screws to the chassis and tighten each screw to 8 in-lb (0.9 N·m).

Step 11 If you have removed any power supplies before moving the chassis, reinstall each one as follows:

- a. Determine which power supply slots to fill and ensure that each of those slots is open.

If you are using the combined or power supply redundancy mode, you can use any slot for the power supply that you are installing.

If you are using the input-source or full redundancy mode, you must group the power supplies that are to be connected to the same grid on either the left or right power supply slots in the chassis (that is, place the power supplies for grid A in slots 1 or 2 or both slots and place the power supplies for grid B in slots 3 or 4 or both slots).

For information on the power supplies supported by Cisco MDS 9700 series switches, see the [Power Supply](#) section under the Product Overview chapter.

- b. Place one hand on the front of the power supply and place your other hand under it to support its weight.
- c. Align the power supply to an open power supply slot.

Note The alignment bracket on top of the power supply should align to a track at the top of the slot and a bar at the bottom of the power supply should be guided by a track at the bottom of the slot.

Step 12 Slide the power supply all the way into the slot until its release handle clicks and the module stops.

Installing the Cisco MDS 9710 and MDS 9718 Series Switch on a Four-Post Rack or Cabinet

This section is applicable to the Cisco MDS 9710 and Cisco MDS 9718 switches.

Before You Begin

- Verify that the chassis shipment is complete and undamaged.
- Verify that a rack or cabinet is installed and secured to the subfloor.

**Warning** **Stability hazard**

The rack stabilizing mechanism must be in place, or the rack must be bolted to the floor before you slide the unit out for servicing. Failure to stabilize the rack can cause the rack to tip over. Statement 1048

- Verify that the bottom-support rails have been attached to the lowest possible RU in the rack or cabinet and there is 14 RU (24.5 inches [62.2 cm]) of space above the rails to install the chassis.
- For Cisco MDS 9718 chassis, verify that the bottom-support rails have been attached to the lowest possible RU in the rack or cabinet and there is 25 RU (43.75 inches [111 cm]) of space above the rails to install the chassis.
- If there are other devices in the rack, verify that the devices that are heavier than this chassis are installed below where you are going to install the chassis and lighter devices are installed above where you are going to install the chassis.
- Verify that the data center ground is accessible where you are installing the chassis.
- Verify that you have the following tools and equipment:
 - Mechanical lift capable of lifting the full weight of the chassis and its installed modules



Caution If the rack is on wheels, ensure that the brakes are engaged or that the rack is otherwise stabilized. If connecting a Cisco MDS 9700 Series switch to a 110-VAC power system, ensure that sufficient power is provided to meet the chassis power requirements for the number of modules installed.



Caution All power supplies must be grounded. The receptacles of the AC power cables used to provide power to the chassis must be the grounding type, and the grounding conductors should connect to protective earth ground at the service equipment. For a Cisco MDS 9700 Series switch with a DC power supply, a grounding cable must be connected to the terminal block.

When connected to 220 VAC, the 3000-W AC power supplies DS-CAC97-3KW for the Cisco MDS 9700 Series switch are designed to provide an output power of 3000 W to power the modules and fans. When connected to a 110 VAC power system, the power supply provides approximately 1450 W. In this case, and if the power supplies are used in redundant rather than combined mode, they might not provide adequate power, depending on the number of modules loaded in the chassis.

If a 110-VAC input is chosen, a 110-VAC power cord (CAB-7513AC=) must be ordered separately.



Warning When installing or replacing the unit, the ground connection must always be made first and disconnected last. Statement 1046



Note Fully loaded, the Cisco MDS 9710 chassis can weigh up to 449.5 lb (203.8 kg), and the Cisco MDS 9718 chassis can weigh up to 923 lb (419 kg). You can lighten the chassis for easier moving by removing its power supplies, fan modules, and fabric modules. To determine the full weight of the chassis and the appropriate weight rating for the mechanical lift, see “Weights and Quantities for the Chassis, Modules, Fan Modules, and Power Supplies”.



Caution You must use a mechanical lift or floor jack to elevate a switch weighing over 120 pounds (55 kg).

- Phillips-head torque screwdriver
- Bottom-support rails kit (shipped with the accessory kit)

Part of this kit has already been used to install the bottom-support rails. You should still have 14 12-24 x 3/4-inch or M6 x 19 mm Phillips screws, which are required for attaching the chassis to the rack.



Note You should also have at least two persons to push the chassis when you slide it onto the rack.



Note To prevent bodily injury when mounting or servicing this unit in a rack, you must take special precautions to ensure that the system remains stable. The following guidelines are provided to ensure your safety:

- This unit should be mounted at the bottom of the rack if it is the only unit in the rack.
- When mounting this unit in a partially filled rack, load the rack from the bottom to the top with the heaviest component at the bottom of the rack.
- If the rack is provided with stabilizing devices, install the stabilizers before mounting or servicing the unit in the rack.

Statement 1006

Installing the Cisco MDS 9700 Series Switch on a Four-Post Rack or Cabinet

To install MDS 9700 Series switch on a four-post rack or cabinet, perform the following steps:

-
- Step 1** If you need to make the chassis as light as possible for moving, you can optionally remove the fabric modules, fan modules, and power supplies.

- a) To remove a power supply, follow these steps:
1. Slide the handle in the middle of the ejector lever towards the end of the lever and rotate the lever away from the power supply.
 2. Pull the power supply a couple of inches (about 5 cm) out of the chassis.
 3. Place one hand under the power supply to support its weight and pull the power supply out of the chassis.
 4. Place the power supply on an antistatic surface.
- b) To remove a fan module, follow these steps:
1. Unscrew the four captive screws on the front of the fan module (one captive screw in each corner of the front of the fan module).
 2. Hold both handles on the fan module with both of your hands and pull the fan module out of the chassis.
 3. Place the fan module on an antistatic surface.
- c) To remove a fabric module, follow these steps:
- Note** Before you can remove a fabric module, you must remove the fan module that is installed in front of it.
1. Press the lever eject button found in the middle of the front of the module.
 2. Rotate both of the levers away from the fabric module.
 3. When the other end of each lever is no longer holding onto the chassis, pull the two levers to slide the module a couple inches out of the chassis.
 4. Rotate the two levers back to the fabric module. Each lever will click when locked in place.
 5. Place one hand on the front of the module and place your other hand under the module to support its weight.
 6. Slide the module out of the chassis and place the module on an antistatic surface.

Step 2

Load the chassis onto a mechanical lift or floor jack as follows:

- a. Position the mechanical lift next to the shipping pallet that holds the chassis.
- b. Elevate the lift platform to the level of the bottom of the chassis (or no more than 1/4 inch [0.635 cm] below the bottom of the chassis).
- c. Use two persons to slide the chassis fully onto the lift so that the side of the chassis touches or is close to the vertical rails on the lift. Make sure that the front and rear of the chassis are unobstructed so you can easily push the chassis into the rack.

Warning To prevent personal injury or damage to the chassis, never attempt to lift or tilt the chassis using the handles on modules (such as power supplies, fans, or cards); these types of handles are not designed to support the weight of the unit. Statement 1032

Caution To lift the chassis, use a mechanical lift. Do not use the handles on the side of the chassis (the handles are not rated for lifting over 200 pounds [91 kg]). Use the side handles for only repositioning the chassis after it is already on the mechanical lift or in the rack or cabinet.

Step 3 Use the mechanical lift to move and align the rear of the chassis to the front of the rack or cabinet. Make sure that the bottom of the chassis is elevated to the height of the bottom-support rails or no more than 1/4 inch (0.6 cm) above the rails.

Note The Cisco MDS 9700 Series switch has the front-to-back cold-aisle and hot-aisle air flow design. We recommend that you maintain a minimum air space of 7 inches (30.5 cm) at the chassis front and back air vents.

Step 4 Push the chassis halfway onto the rack or cabinet.

Figure 8: Moving a Chassis onto a Rack or Cabinet - Cisco MDS 9710 Chassis

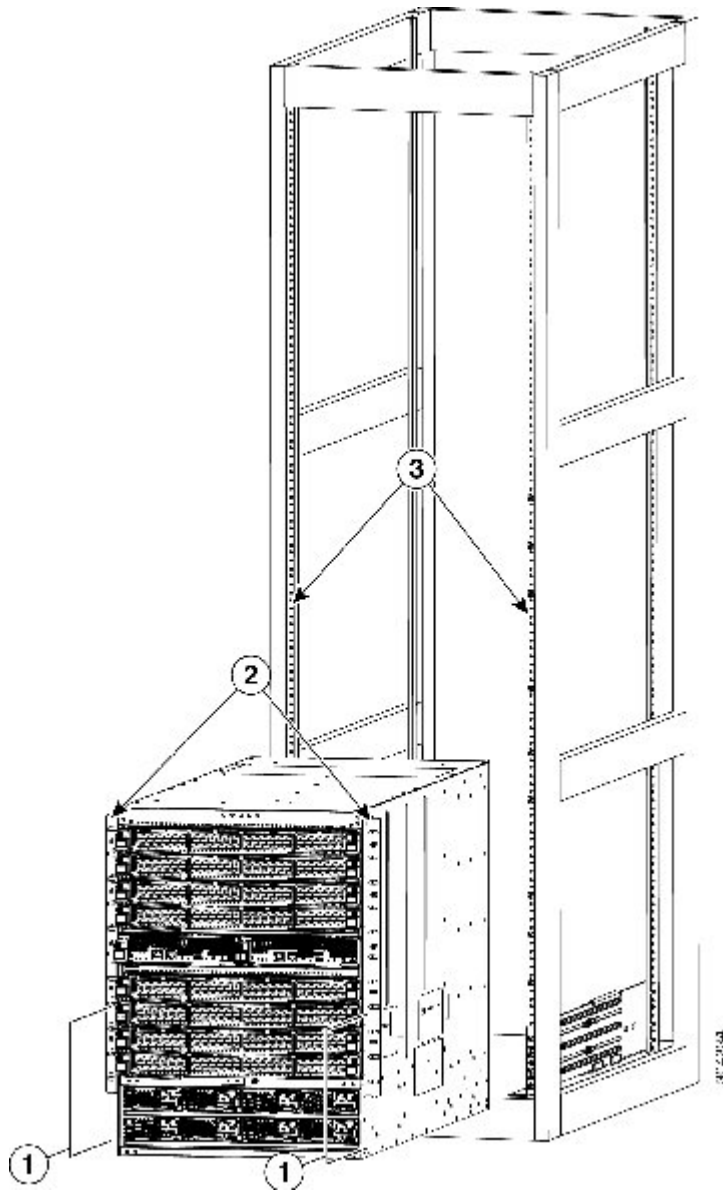

1	Push the sides of the lower half of the front side of the chassis.	3	Rack vertical mounting rails.
---	--	---	-------------------------------

2	Chassis mounting brackets.		
---	----------------------------	--	--

Use two persons to push the chassis onto the bottom-support rails. Push the lower half of the front side of the chassis so that the back side enters the rack first, and push until the chassis is halfway onto the rack. See the following image. Ensure that the chassis does not get caught on any of the expansion edges of the bottom-support rail.

Figure 9: Moving a Chassis onto a Rack or Cabinet - Cisco MDS 9718 Chassis

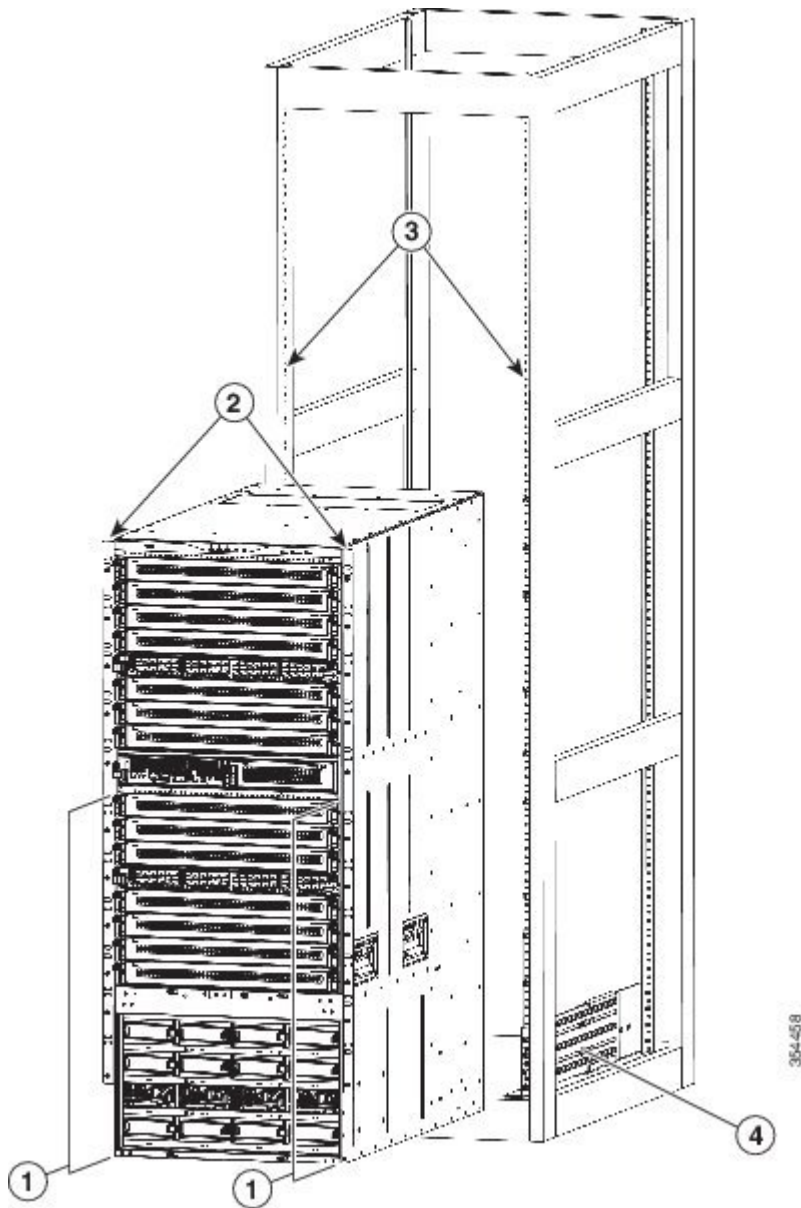

1	Push the sides of the lower half of the front side of the chassis (do not push on any of the modules or module handles).	3	Rack vertical mounting rails.
2	Chassis mounting brackets.	4	Bottom support rails

Tip To adjust the placement of the chassis on the bottom-support rails, you can use the handles on the sides of the chassis.

Step 5 If the mechanical lift is raised above the height of the bottom-support rails, gently lower it to the level of the rails or no more than 1/4 inch (0.6 cm) below the rails.

This action helps to prevent the bottom of the chassis from getting caught on the bottom expansion edges of the bottom-support rails.

Step 6 Push the chassis all the way onto the rack so that the vertical mounting brackets on the chassis come in contact with the vertical mounting rails on the rack.

Step 7 Use seven M6 x 19 mm or 24 x 3/4-inch screws to attach each of the two vertical mounting brackets on the chassis to the two vertical mounting rails on the rack (total of 14 screws). See the following image.

Figure 10: Attaching the Chassis to the Rack - Cisco MDS 9710 Chassis

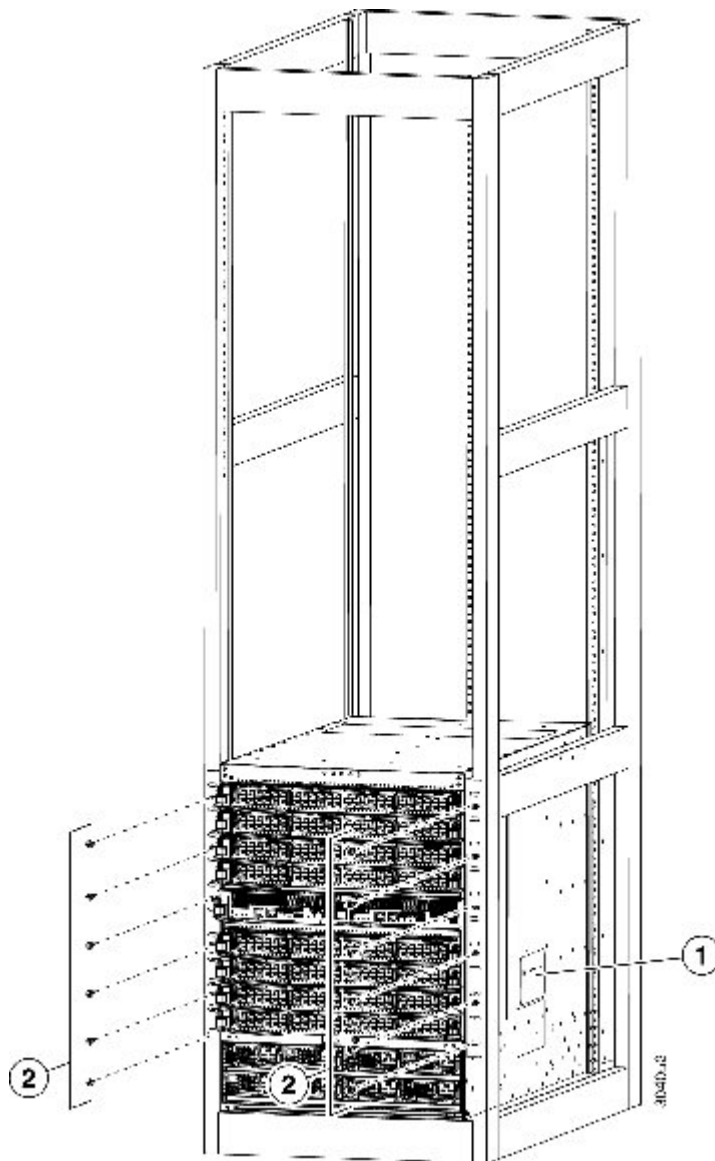

1	Handles used to adjust the chassis placement	2	Nine M6 x 19 mm or 10-24 x 3/4 in. Phillips screws used to attach each side bracket to a front mounting rail (use a total of 18 screws)
---	--	---	---

Figure 11: Attaching the Chassis to the Rack - Cisco MDS 9718 Chassis

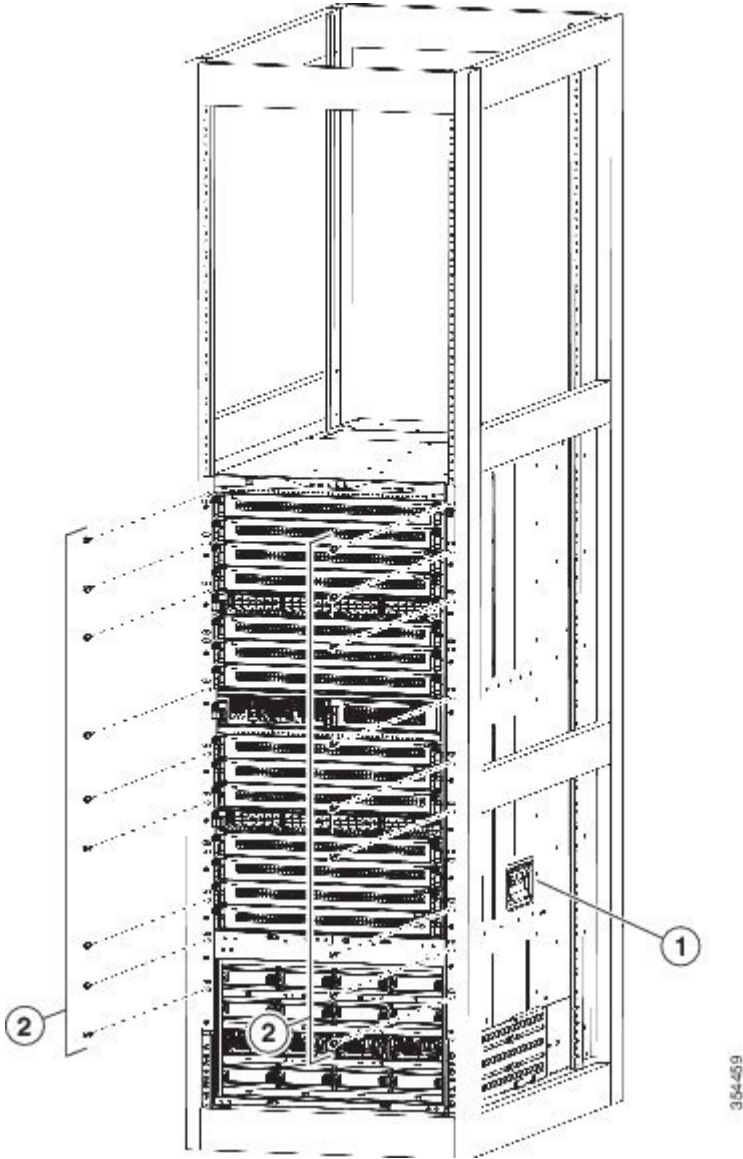

1	Handles used to adjust the chassis placement	2	Nine M6 x 19 mm or 10-24 x 3/4 in. Phillips screws used to attach each side bracket to a front mounting rail (use a total of 18 screws)
---	--	---	---

Step 8

If you removed any fabric modules before moving the chassis, replace each one in the chassis as follows:

- a. Holding the front of the fabric module (the side with the LEDs), turn the module so that the front side is vertical.

Note The top of the module has an alignment bracket running from the rear to the front. The electrical connectors will be at the bottom.
- b. Align the rear of the fabric module to an open fabric slot and insert the bracket on top of the module into the track at the top of the slot.

Note If there are only three fabric modules to install, install them in fabric slots 1, 3, and 5, and be sure that there are blank filler plates installed in the open slots.
- c. Slide the module part way into the slot.
- d. Press the ejector button on the front of the module, to release the levers from the front of the module.
- e. Rotate the levers away from the front of the module and hold them while sliding the module all the way into the slot.
- f. Simultaneously rotate both levers to the front of the module. They click when locked to the front of the module.

Step 9

If you removed any fan modules before moving the chassis, reinstall each one in the chassis as follows:

- a. Holding each of the two handles on the fan module with your two hands, align the fan module to an open fan module slot.

Note The two alignment brackets on top of the fan module should align to two tracks at the top of the slot.
- b. Slide the fan module into the slot until the front of the fan module comes in contact with the rear of the chassis.

Note The two alignment pins on the fan module (on the top and one on the bottom) should go into holes in the chassis and the four captive screws on the fan module should align to screw holes in the chassis.
- c. Screw in the four captive screws to the chassis and tighten each screw to 8 in-lb (0.9 N·m).

Step 10

If you removed any power supplies before moving the chassis, reinstall each one as follows:

- a. Determine which power supply slots to fill and ensure that each of those slots is open.
- b. If you are using the combined or power supply redundancy mode, you can use any slot for the power supply that you are installing.

If you are using input-source or full redundancy mode, you must group the power supplies that are to be connected to the same grid on either the left or right power supply slots in the chassis (that is, place the power supplies for grid A in slots 1 or 2 or both slots and place the power supplies for grid B in slots 3 or 4 or both slots).
- c. Place one hand on the front of the power supply and place your other hand under it to support its weight.
- d. Align the power supply to an open power supply slot.

Note The alignment bracket on top of the power supply should align to a track at the top of the slot and a bar at the bottom of the power supply should be guided by a track at the bottom of the slot.
- e. Slide the power supply all the way into the slot until it stops.
- f. Slide the handle in the middle of the ejector lever toward the end of the lever and rotate the lever to the front of the power supply. Release the middle handle.

Note The lever should grab the inside of the slot and push the power supply onto its mid-plane connectors.

- If you are using the combined power or power-supply redundancy mode, you can fill any power supply slot with the power supplies. If you are using input-source or full redundancy modes, you must place half of the power supplies in slots 1 and 2, and you must place the other half of the power supplies in slots 3 and 4 (half will be used for available power and the other half will be used for redundant power).
 - In a single phase AC power supply unit, connection of multiple phases from the same three-phase source is supported and direct connection of three-phase is not supported.
- g. Screw in the two captive screws on the front of the power supply to the chassis. Tighten each screw to 8 in-lb (0.9 N·m)

System Grounding

This section describes the need for system grounding and explains how to prevent damage from electrostatic discharge.

Proper Grounding Practices

Grounding is one of the most important parts of equipment installation. Proper grounding practices ensure that the buildings and the installed equipment within them have low-impedance connections and low-voltage differentials between chassis. When you properly ground systems during installation, you reduce or prevent shock hazards, equipment damage due to transients, and data corruption. [Table 3-1](#) lists grounding best practices.

Table 1: Grounding Best Practices

Environment	Electromagnetic Noise Severity Level	Grounding Recommendations
Commercial building is subjected to direct lightning strikes. For example, some places in the United States, such as Florida, are subject to more lightning strikes than other areas.	High	All lightning protection devices must be installed in strict accordance with manufacturer recommendations. Conductors carrying lightning current should be spaced away from power and data lines in accordance with applicable recommendations and codes. Appropriate grounding practices must be closely followed.
Commercial building is located in an area where lightning storms frequently occur but is not subject to direct lightning strikes.	High	Appropriate grounding practices must be closely followed.
Commercial building contains a mix of information technology equipment and industrial equipment, such as welding.	Medium to high	Appropriate grounding practices must be closely followed.

Existing commercial building is not subject to natural environmental noise or man-made industrial noise. This building contains a standard office environment. This installation has a history of malfunction due to electromagnetic noise.	Medium	Appropriate grounding practices must be closely followed. Determine source and cause of noise if possible, and mitigate as closely as possible at the noise source or reduce coupling from the noise source to the victim equipment.
New commercial building is not subject to natural environmental noise or man-made industrial noise. This building contains a standard office environment.	Low	Appropriate grounding practices should be followed as closely as possible. Electromagnetic noise problems are not anticipated, but installing a best practice grounding system in a new building is often the least expensive route and the best way to plan for the future.
Existing commercial building is not subject to natural environmental noise or man-made industrial noise. This building contains a standard office environment.	Low	Appropriate grounding practices should be followed as much as possible. Electromagnetic noise problems are not anticipated, but installing a best practice grounding system is always recommended.



Note In all situations, grounding practices must comply with local National Electric Code (NEC) requirements or local laws and regulations.



Note Always ensure that all the modules are completely installed and that the captive installation screws are fully tightened. In addition, ensure that all I/O cables and power cords are properly seated. These practices are normal installation practices and must be followed in all installations.

Preventing Electrostatic Discharge Damage

Electrostatic discharge (ESD) damage, which can occur when modules or other Field Replaceable Units (FRU - a circuit board, part, or an assembly which can be easily removed and replaced without having to send the entire product to a repair facility.) are improperly handled, results in intermittent or complete failures. Modules consist of printed circuit boards that are fixed in metal carriers. Electromagnetic interference (EMI) shielding and connectors are integral components of the carrier. Although the metal carrier helps protect the board from ESD. Always wear an ESD grounding strap when handling modules.

Follow these guidelines for preventing ESD damage:

- Always wear an ESD wrist strap and ensure that it makes maximum contact with bare skin. ESD grounding straps are available with banana plugs, metal spring clips, or alligator clips. All Cisco MDS 9700 Series devices are equipped with a banana plug connector (identified by the ground symbol next to the connector) somewhere on the front panel. We recommend that you use a personal ESD grounding strap equipped with a banana plug.
- If you choose to use the disposable ESD wrist strap supplied with most FRUs or an ESD wrist strap equipped with an alligator clip, you must attach the system ground lug to the chassis in order to provide a proper grounding point for the ESD wrist strap.



Note This system ground is also referred to as the network equipment building system (NEBS) ground.

- If your chassis does not have the system ground attached, you must install the system ground lug. For installation instructions and location of the chassis system ground pads, see [“Establishing the System Ground” section](#).



Note You do not need to attach a supplemental system ground wire to the system ground lug; the lug provides a direct path to the bare metal of the chassis.

Establishing the System Ground

This section describes how to connect a system ground to the MDS 9700 Series switch.



Note This system ground is also referred to as the network equipment building system (NEBS) ground.

You must use the system (NEBS) ground on both AC- and DC-powered systems if you are installing this equipment in a U.S. or European Central Office.

The system (NEBS) ground provides additional grounding for EMI shielding requirements and grounding for the low-voltage supplies (DC-DC converters) on the modules and is intended to satisfy the Telcordia Technologies NEBS requirements for supplemental bonding and grounding connections. You must observe the following system grounding guidelines for your chassis:

- You must install the system (NEBS) ground connection with any other rack or system power ground connections that you make. The system ground connection is required if this equipment is installed in a U.S. or European Central Office.
- You must connect both the system (NEBS) ground connection and the power supply ground connection to an earth ground. The system (NEBS) ground connection is required if this equipment is installed in a U.S. or European Central Office.
- For Cisco MDS 9700 Series devices that are equipped with DC-input power supplies, you must install the system (NEBS) ground before you attach the source DC power cables to the DC PEM. If the chassis is powered up, you must power down the chassis before attaching the system (NEBS) ground. If you are installing the system (NEBS) ground on models of the Cisco MDS 9700 chassis that are equipped with either AC-input or DC-input power supplies, you do not need to power down the chassis.



Note The system (NEBS) ground serves as the primary safety ground for the MDS 9700 Series switch that are equipped with DC-input PEMs. The DC-input power supplies for these chassis do not have a separate ground.

Required Tools and Equipment

After you install the system ground lug, follow these steps to correctly attach the ESD wrist strap:

Before you begin

To connect the ground system, you need the following tools and materials:

- Grounding lug—A two-hole standard barrel lug. Supports up to 6 AWG wire. Supplied as part of accessory kit.
- Grounding screws—Two M4 x 8mm (metric) pan-head screws. Supplied as part of the accessory kit.
- Grounding wire—Not supplied as part of accessory kit. The grounding wire should be sized according to local and national installation requirements. Depending on the power supply and system, a 6 AWG copper conductor is required for U.S. installations. Commercially available 6 AWG wire is recommended. The length of the grounding wire depends on the proximity of the switch to proper grounding facilities.



Note For safety on a ground fault, we recommend that you should avoid using a grounding wire that is smaller than the power wire. The grounding wire must be sized to meet local and national standard for installation requirements.

- No. 1 Phillips screwdriver.
- Crimping tool to crimp the grounding wire to the grounding lug.
- Wire-stripping tool to remove the insulation from the grounding wire.

-
- Step 1** Attach the ESD wrist strap to bare skin as follows:
- a. If you are using the ESD wrist strap supplied with the FRUs, open the wrist strap package and unwrap the ESD wrist strap. Place the black conductive loop over your wrist and tighten the strap so that it makes good contact with your bare skin.
 - b. If you are using an ESD wrist strap equipped with an alligator clip, open the package and remove the ESD wrist strap. Locate the end of the wrist strap that attaches to your body and secure it to your bare skin.
- Step 2** Grasp the spring or alligator clip on the ESD wrist strap and momentarily touch the clip to a bare metal spot (unpainted surface) on the rack. We recommend that you touch the clip to an unpainted rack rail so that any built-up static charge is then safely dissipated to the entire rack.
- Step 3** To plug the strap into the port (and alternatively clip an alligator clip onto the grounding lug screws) attach either the spring clip or the alligator clip to the ground lug screw.
- a. If you are using the ESD wrist strap that is supplied with the FRUs, squeeze the spring clip jaws open, position the spring clip to one side of the system ground lug screw head, and slide the spring clip over the lug screw head so that the spring clip jaws close behind the lug screw head.
- Note** The spring clip jaws do not open wide enough to fit directly over the head of the lug screw or the lug barrel.

- b. If you are using an ESD wrist strap that is equipped with an alligator clip, attach the alligator clip directly over the head of the system ground lug screw or to the system ground lug barrel.
- c. Follow these additional guidelines when handling modules:
 - Handle carriers by available handles or edges only; avoid touching the printed circuit boards or connectors.
 - Place a removed component board-side-up on an antistatic surface or in a static shielding container. If you plan to return the component to the factory, immediately place it in a static shielding container.
 - Never attempt to remove the printed circuit board from the metal carrier.

Caution For safety reasons, check the resistance value of the antistatic strap periodically. The measurement should be between 1 and 10 megohm (Mohm).
