



# Supported Message Formats

---

Published: March 12, 2015

## Supported Diameter Messages

The messages sent and received by the diameter infrastructure are as follows:

- Capability Exchange Request (CER)—Sent upon new connection establishment from the SCE to peer. The main purpose of this message is to advertise which applications are supported by peers. It also includes some other details such as realm, host, and so on.
- Capability Exchange Answer (CEA)—Responds to the CER message.
- Watch Dog Request (WDR)—Sent by one peer to another. The purpose is to ensure that the connection is up and running. If three watch dog messages in a row are not answered, the connection is closed and reopened, and only after three messages are answered will it be considered up.
- Watch Dog Answer (WDA)—Responds to WDR message.
- Disconnect Peer Request (DPR)—Tells the peer that the connection will be disconnected.
- Disconnect Peer Answer (DPA)—Responds to the DPR message.

Figure 1-1 displays the typical connection flow of diameter messages and responses.

**Figure 1-1** Typical Connection Flow

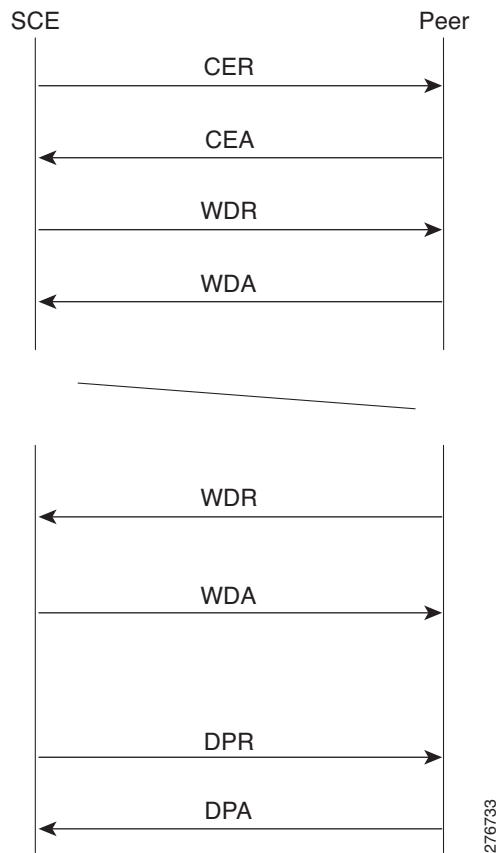

The SCE initiates the TCP connection (the only transport layer currently supported by SCE). After the TCP connection is established, the SCE sends the CER message. The CER message is answered by the CEA message. At this stage the connection is up. The WDR and WDA messages are exchanged between the peers. The time gap between watch dog messages is defined by the Tx timer. If the peer is removed, the connection is gracefully closed by sending the DPR message and receiving the DPA message.

# Gx-Supported Messages

The following messages are supported:

- **Credit Control Request (CCR)**—The CCR message indicates Gx diameter session create, update, and close.
 

CCR Initiate is sent by the SCE to the PCRF (Gx Server) upon login of a subscriber (for example, using SceSubscriberAPI) or upon new flow mapped to a Gx anonymous group. Upon login, the CCR includes parameters that identify the subscriber to the PCRF, such as Framed-ip and Subscription-Id (not on anonymous-group).

CCR Terminate is sent on logout.
- **Credit Control Answer (CCA)**—A CCA message is sent from the server to the SCE.
  - Responding to a CCR Initial request—The CCA message includes the subscriber policy parameters and RADIUS VSA attributes (or some subset of it).
  - Responding to a CCR Terminate request—The CCA message generally includes only results of the action.
- **Re-Authorize Request (RAR)**—A RAR message is initiated by the PCRF. The RAR message can include new parameters (package, and so on) and RADIUS VSA attributes. The RAR message is initiated by an external event.
- **Re-Authorize Answer (RAA)**—A RAA message is the response to the RAR. It usually includes the result of the action.
- **Abort Session Request (ASR)**—An ASR message is sent from the PCRF to the SCE to close the subscriber session, and in some cases to trigger a logout of the subscriber. A subscriber owned by a Gx (anonymous group manager), is logged out.
- **Abort Session Answer (ASA)**—An ASA message is the response to ASR message and usually contains the result of the action.

## Credit Control Request (CCR)

Command-Code Field	Command Flags Field	Direction	Description
272	'R' bit set	SCE to PCRF	Sent to: <ul style="list-style-type: none"> <li>• Request SCE rules for a subscriber</li> <li>• Indicate termination of the subscriber</li> </ul>

**Message Format:**

```

<CC-Request> ::= < Diameter Header: 272, REQ, PXY >
                < Session-Id >
                { Auth-Application-Id }
                { Origin-Host }
                { Origin-Realm }
                { Destination-Realm }
                { CC-Request-Type }
                { CC-Request-Number }
                [ Destination-Host ]
                [ Framed-IP-Address ]
                [ Subscription-Id ]

```

The format of the Session-Id is "pid; ip; time", where:

- PID is a 32-bit integer type indicating the unique PID for a specific Gx session.
- IP is a 32-bit unsigned integer type indicating the framed IP of the subscriber for which the session is created. IP is in decimal format.

TIME is a 32-bit unsigned integer type indicating the time when session is created. Time is in number of seconds starting from January 1, 1970.

**Message Response:**

- Auth-Application-Id is set to the application ID of the Gx protocol.
- Origin-Host is set to the SCE host id (its IP).
- Origin-Realm is set to "SCE" defined realm.
- Destination-Host and Destination-Realm define the PCRF destination. The destination host is not mandatory, it depends on the SCE and PCRF configurations.
- CC-Request-Type is set to "Initial" on session creation (SCE login) and "Termination" on session termination (SCE logout).  
CC-Request-Number is a unique number within a session-id.
- Framed-IP-Address and Subscription-Id will be sent depending on the scenario.

**Case 1: Login mode**

- The CCR includes both parameters.
- Framed-IP-Address is the IP address of the subscriber. (Will not be sent on "TERMINATE".)
- Subscription-Id is set to the subscriber-ID used by the SCE (for example, IMSI/MSISDN).
- The subscription-Id will be introduced to the SCE by a different API.

**Case 2: Pull mode**

- The CCR includes only the Framed-IP-Address AVP. The subscription-Id is returned as part of the CCA.
- Framed-IP-Address is the IP address of the subscriber.
- In this mode, the Gx interface is also used to introduce the subscribers to the SCE.

**Sample Message Login mode:**

```
Version          = 1
Message Length  = XXX
Command Flags   = REQ, PXY
Command Code    = Credit-Control-Request (272)
Application Id  = 16777238
AVPs
  Session-Id    = "27; 3232262425; 1311857000"
  Auth-Application-Id = 16777238
  Origin-Host    = "10.101.23.34"
  Origin-Realm   = "sce"
  Destination-Realm = "att.com"
  Destination-Host = "PCRF host"
  CC-Request-Type = INITIAL_REQUEST (1)
  CC-Request-Number = 0
  Framed-IP-Address = 10.10.1.10
  Subscription-Id = 05412345566
```

**Sample Message Pull mode:**

```
Version          = 1
Message Length  = XXX
Command Flags   = REQ, PXY
Command Code    = Credit-Control-Request (272)
Application Id  = 16777238
AVPs
  Session-Id    = "27; 3232262425; 1311857000"
  Auth-Application-Id= 16777238
  Origin-Host    = "10.101.23.34"
  Origin-Realm   = "sce"
  Destination-Realm = "att.com"
  Destination-Host = "PCRF host"
  CC-Request-Type = INITIAL_REQUEST (1)
  CC-Request-Number = 0
  Framed-IP-Address = 10.10.1.10
```

The format of the Session-Id is "pid; ip; time", where:

- PID is a 32-bit integer type indicating the unique PID for a specific Gx session.
- IP is a 32-bit unsigned integer type indicating the framed IP of the subscriber for which the session is created. IP is in decimal format.

TIME is a 32-bit unsigned integer type indicating the time when session is created. Time is in number of seconds starting from January 1, 1970.

## Credit Control Answer (CCA)

The CCA command has two formats:

- CCA Initial
- CCA Update/Terminate

Command-Code Field	Command Flags Field	Direction	Description
272	'R' bit cleared	PCRF to SCE	Sent in response to the CCR command. Used to provision SCE rules and event triggers for the subscriber.

### CCA Initial

#### Message Format:

```
<CC-Answer> ::= < Diameter Header: 272, PXY >
< Session-Id >
{ Auth-Application-Id }
{ Origin-Host }
{ Origin-Realm }
{ CC-Request-Type }
{ CC-Request-Number }
{ Subscription-Id }
  [ Subscription-Id-Type ]
  [ Subscription-Id_Data ]
[ Result-Code ]
[ Cisco-SCA BB-Package-Install ]
[ Cisco-SCA BB-Package-Install ]
[ Cisco-SCA BB-Real-time-monitor-Install ]
[ Cisco-SCA BB-Vlink-Upstream-Install ]
[ Cisco-SCA BB-Vlink-Downstream-Install ]
[ PS-Information ]
  [3GPP-GGSN-Address]
  [3GPP-SGSN-Address]
[CG-Address]
[3GPP-Charging-Id]
[Called-Session-Id]
[3GPP-GPRS-QoS-Negotiated-Profile]
[3GPP-PDP-Type]
[3GPP-SGSN-MCC-MNC]
[3GPP-GGSN-MCC-MNC]
[3GPP-Charging-Characteristics]
[3GPP-RAT-Type]
[3GPP-Selection-Mode]
[3GPP-NSAPI]
[3GPP-MS-Timezone]
[3GPP-User-Location-Info]
[Acct-Multi-Session-ID]
[Acct-Session-ID]
[Acct-Session-Time]
[Calling-Station-ID]
[Class]
[CUI]
[Framed-IP-Address]
[NAS-Identifier]
[NAS-IP-Address]
```

```

[NAS-Port-Type]
[User-Name]
[3GPP-GGSN-Address-Code-7]
[3GPP-IMEISV]
[3GPP-IMSI]
[3GPP-CG-Address]
[3GPP-SGSN-Address-Code-6]
[WiMax-Active-Time]
[WiMax-BSID]

```

**Message Response:**

- Session-Id is set to the CCR Session-Id.
- Auth-Application-Id is set to the same value as the CCR.
- Origin-Host is set to the message generating host (PCRF which responds).
- Origin-Realm is set to the PCRF realm.
- CC-Request-Type and CC-Request-Number are set to the same type as in the CCR.
- Subscription-Id is set to the subscriber-ID used by the SCE.
- Cisco-SCA BB-Package-Install is set to the subscriber assigned package ID.
- Cisco-SCA BB-Real-time-monitor-Install is set to real monitor activation value.
- Cisco-SCA BB-Vlink-Upstream-Install is set to the upstream vlink assigned ID.
- Cisco-SCA BB-Vlink-Downstream-Install is set to the downstream vlink assigned ID.

For Login mode, only the Cisco-SCA BB-Package-Install is mandatory. For Pull mode, both Cisco-SCA BB-Package-Install and Subscription-Id are mandatory. Additional attributes are sorted and can be used by other interfaces, such as Gy.

**Sample Message:**

```

Version          = 1
Message Length  = XXX
Command Flags   = PXY
Command Code    = Credit-Control-Answer (272)
Application Id  = 16777238
AVPs
  Session-Id      = "27; 3232262425; 1311857000"
  Auth-Application-Id = 16777238
  Origin-Host     = "PCRF host"
  Origin-Realm    = "PCRF Realm"
  CC-Request-Type = INITIAL_REQUEST (1)
  CC-Request-Number = 0
  Subscription-Id = 05412345566
    Subscription-Id-Type = END_USER_E164 (0)
    Subscription-Id-Value = 1110123456
  Result-Code     = DIAMETER_SUCCESS
  Cisco-SCA BB-Package-Install = 5
  Cisco-SCA BB-Real-time-monitor-Install = 1

```

The format of the Session-Id is "pid; ip; time", where:

- PID is a 32-bit integer type indicating the unique PID for a specific Gx session.
- IP is a 32-bit unsigned integer type indicating the framed IP of the subscriber for which the session is created. IP is in decimal format.
- TIME is a 32-bit unsigned integer type indicating the time when session is created. Time is in number of seconds starting from January 1, 1970.

**Error Handling**

- If a timeout event occurs, or if a CCA is returned with an error code, the SCE tries to open the session again after 15 seconds, 30 seconds, 60 seconds, and then every 120 seconds.
- Rejection is not supported. To reject a subscriber, the PCRF must return a CCA with a success code that installs a special package used for this purpose.
- If the user is not recognized by the PCRF server, the PCRF should return a CCA with fail code and wait for retry. It is also possible to return a success code that installs the blocking\rejecting\limiting package, and update it later by using RAR, when the PCRF gets new information about the subscriber.

**CCA Update/Terminate****Message Format:**

```

<CC-Answer> ::= < Diameter Header: 272, PXY >
  < Session-Id >
  { Auth-Application-Id }
  { Origin-Host }
  { Origin-Realm }
  { CC-Request-Type }
  { CC-Request-Number }
  [ Result-Code ]
  [ Cisco-SCA BB-Package-Install ]
  [ Cisco-SCA BB-Package-Install ]
  [ Cisco-SCA BB-Real-time-monitor-Install ]
  [ Cisco-SCA BB-Vlink-Upstream-Install ]
  [ Cisco-SCA BB-Vlink-Downstream-Install ]
  [ PS-Information ]
    [3GPP-GGSN-Address]
    [3GPP-SGSN-Address]
  [CG-Address]
  [3GPP-Charging-Id]
  [Called-Session-Id]
  [3GPP-GPRS-QoS-Negotiated-Profile]
  [3GPP-PDP-Type]
  [3GPP-SGSN-MCC-MNC]
  [3GPP-GGSN-MCC-MNC]
  [3GPP-Charging-Characteristics]
  [3GPP-RAT-Type]
  [3GPP-Selection-Mode]
  [3GPP-NSAPI]
  [3GPP-MS-Timezone]
  [3GPP-User-Location-Info]
  [Acct-Multi-Session-ID]
  [Acct-Session-ID]
  [Acct-Session-Time]
  [Calling-Station-ID]
  [Class]
  [CUI]
  [Framed-IP-Address]
  [NAS-Identifier]
  [NAS-IP-Address]
  [NAS-Port-Type]
  [User-Name]
  [3GPP-GGSN-Address-Code-7]
  [3GPP-IMEISV]
  [3GPP-IMSI]
  [3GPP-CG-Address]
  [3GPP-SGSN-Address-Code-6]

```



```
[WiMax-Active-Time]
[WiMax-BSID]
```

**Message Response:**

- Session-Id is set to the CCR Session-Id.
- Auth-Application-Id is set to the same value as the CCR.
- Origin-Host is set to the message generating host (PCRF which responds).
- Origin-Realm is set to the PCRF realm.
- CC-Request-Type and CC-Request-Number are set to the same type as in the CCR.
- Cisco-SCA BB-Package-Install is set to the subscriber assigned package ID.
- Cisco-SCA BB-Real-time-monitor-Install is set to real monitor activation value.
- Cisco-SCA BB-Vlink-Upstream-Install is set to the upstream vlink assigned ID.
- Cisco-SCA BB-Vlink-Downstream-Install is set to the downstream vlink assigned ID.

**Sample Message:**

```
Version          = 1
Message Length  = XXX
Command Flags   = PXY
Command Code    = Credit-Control-Answer (272)
Application Id  = 16777238
AVPs
  Session-Id      = "27; 3232262425; 1311857000"
  Auth-Application-Id= 16777238
  Origin-Host     = "PCRF host"
  Origin-Realm    = "PCRF Realm"
  CC-Request-Type = UPDATE_REQUEST (1)
  CC-Request-Number = 1
  Result-Code     = DIAMETER_SUCCESS
  Cisco-SCA BB-Package-Install = 5
  Cisco-SCA BB-Real-time-monitor-Install = 1
```

The format of the Session-Id is "pid; ip; time", where:

- PID is a 32-bit integer type indicating the unique PID for a specific Gx session.
- IP is a 32-bit unsigned integer type indicating the framed IP of the subscriber for which the session is created. IP is in decimal format.
- TIME is a 32-bit unsigned integer type indicating the time when session is created. Time is in number of seconds starting from January 1, 1970.

**Error Handling**

No errors are supported.

For a Terminate message if timeout or error occurs, the SCE updates the appropriate counter and closes the session.

## Re-Authorize Request (RAR)

Command-Code Field	Command Flags Field	Direction	Description
258	'R' bit set	PCRF to SCE	Sent to provision SCE rules using the PUSH procedure to initiate the provisioning of unsolicited SCE rules. It is used to provision SCE rules for the subscriber.

### Message Format:

```
<RA-Request> ::= < Diameter Header: 258, REQ, PXY >
  < Session-Id >
  { Auth-Application-Id }
  { Origin-Host }
  { Origin-Realm }
  { Destination-Realm }
  { Destination-Host }
  { Re-Auth-Request-Type }
  [ Framed-IP-Address ]
  { Subscription-Id }
  [ Cisco-SCA BB-Package-Install ]
  [ Cisco-SCA BB-Real-time-monitor-Install ]
  [ Cisco-SCA BB-Vlink-Upstream-Install ]
  [ Cisco-SCA BB-Vlink-Downstream-Install ]
  [ PS-Information ]
    [3GPP-GGSN-Address]
    [3GPP-SGSN-Address]
  [CG-Address]
  [3GPP-Charging-Id]
  [Called-Session-Id]
  [3GPP-GPRS-QoS-Negotiated-Profile]
  [3GPP-PDP-Type]
  [3GPP-SGSN-MCC-MNC]
  [3GPP-GGSN-MCC-MNC]
  [3GPP-Charging-Characteristics]
  [3GPP-RAT-Type]
  [3GPP-Selection-Mode]
  [3GPP-NSAPI]
  [3GPP-MS-Timezone]
  [3GPP-User-Location-Info]
  [Acct-Multi-Session-ID]
  [Acct-Session-ID]
  [Acct-Session-Time]
  [Calling-Station-ID]
  [Class]
  [CUI]
  [NAS-Identifier]
  [NAS-IP-Address]
  [NAS-Port-Type]
  [User-Name]
  [3GPP-GGSN-Address-Code-7]
  [3GPP-IMEISV]
  [3GPP-IMSI]
  [3GPP-CG-Address]
  [3GPP-SGSN-Address-Code-6]
  [WiMax-Active-Time]
  [WiMax-BSID]
```

**Message Response:**

- Session-Id is set to the CCR Session-Id.
- Auth-Application-Id is set to the same value as the CCR.
- Origin-Host is set to the message generating host (PCRF which responds).
- Origin-Realm is set to the PCRF realm.
- CC-Request-Type and CC-Request-Number are set to the same type as in the CCR.
- Subscription-id is set to the subscriber-ID used by the SCE.
- Cisco-SCA BB-Package-Install is set to the subscriber assigned package ID.
- Cisco-SCA BB-Real-time-monitor-Install is set to real monitor activation value.
- Cisco-SCA BB-Vlink-Upstream-Install is set to the upstream vlink assigned ID.
- Cisco-SCA BB-Vlink-Downstream-Install is set to the downstream vlink assigned ID.

**Sample Message:**

```

Version          = 1
Message Length  = XXX
Command Flags   = REQ, PXY
Command Code    = Re-Auth-Request (258)
Application Id  = 16777238
AVPs
  Session-Id      = "27; 3232262425; 1311857000"
  Auth-Application-Id = 16777238
  Origin-Host     = "PCRF Host"
  Origin-Realm    = "PCRF Realm"
  Destination-Realm = "SCE Realm"
  Destination-Host = "SCE Host"
  Re-Auth-Request-Type = AUTHORIZE_ONLY (0)
  Framed-IP-Address = 10.1.1.1
  Subscription-Id   = 05412321312
  Cisco-SCA BB-Package-Install = 5

```

The format of the Session-Id is "pid; ip; time", where:

- PID is a 32-bit integer type indicating the unique PID for a specific Gx session.
- IP is a 32-bit unsigned integer type indicating the framed IP of the subscriber for which the session is created. IP is in decimal format.
- TIME is a 32-bit unsigned integer type indicating the time when session is created. Time is in number of seconds starting from January 1, 1970.

## Re-Authorize Answer (RAA)

Command-Code Field	Command Flags Field	Direction	Description
258	'R' bit cleared	SCE to PCRF	Sent in response to the RAR command.

**Message Format:**

```

<RA-Answer> ::= < Diameter Header: 258, PXY >
                < Session-Id >
                { Origin-Host }

```

```

    { Origin-Realm }
    [ Result-Code ]
    [ Error-Message ]

```

**Sample Message:**

```

Version           = 1
Message Length   = XXX
Command Flags    = REQ, PXY
Command Code     = Re-Auth-Request (258)
Application Id   = 16777238
AVPs
  Session-Id      = "27; 3232262425; 1311857000"
  Auth-Application-Id= 16777238
  Origin-Host     = "SCE Host"
  Origin-Realm    = "SCE Realm"
  Error-Code      = DIAMETER_SUCCESS

```

The format of the Session-Id is "pid; ip; time", where:

- PID is a 32-bit integer type indicating the unique PID for a specific Gx session.
- IP is a 32-bit unsigned integer type indicating the framed IP of the subscriber for which the session is created. IP is in decimal format.
- TIME is a 32-bit unsigned integer type indicating the time when session is created. Time is in number of seconds starting from January 1, 1970.

**Error Handling:**

- DIAMETER\_UNKNOWN\_SESSION\_ID is returned if no such session id exists in the SCE database.
- DIAMETER\_UNABLE\_TO\_COMPLY is returned when the RAR is received in the middle of initiating new session (CCR-I was sent). SCE can also return this error code when the update fails for an unknown reason.
- DIAMETER\_INVALID\_AVP\_VALUE is returned when the value of an AVP is not valid; for example, package out of range.
- DIAMETER\_MISSING\_AVP\_SCE is returned when the message format of the RAR is not valid.

## Abort Session Request (ASR)

Command-Code Field	Command Flags Field	Direction	Description
274	'R' bit set	Server to access device	May be sent by any server to the access device providing session service, requesting it to stop the session identified by the Session-Id.

**Message Format:**

```

<ASR> ::= < Diameter Header: 274, REQ, PXY >
         < Session-Id >
         { Origin-Host }
         { Origin-Realm }
         { Destination-Realm }

```

```
{ Destination-Host }
{ Auth-Application-Id }
```

**Message Response:**

- Origin-Host is set to the SCE host ID (its IP).
- Origin-Realm is set to the SCE-defined realm.
- Destination-Host and Destination-Realm define the PCRF destination. The destination host is not mandatory, it depends on the SCE and PCRF configurations.
- Auth-Application-Id is set to the application ID of the Gx protocol.

**Sample Message:**

```
Version          = 1
Message Length  = XXX
Command Flags   = REQ, PXY
Command Code    = Re-Auth-Request (274)
Application Id  = 16777238
AVPs
  Session-Id      = "27; 3232262425; 1311857000"
  Auth-Application-Id= 16777238
  Origin-Host     = "PCRF Host"
  Origin-Realm    = "PCRF Realm"
  Destination-Realm = "att.com"
  Destination-Host = "SCE host"
  Auth=Application-id = 16777238
```

The format of the Session-Id is "pid; ip; time", where:

- PID is a 32-bit integer type indicating the unique PID for a specific Gx session.
- IP is a 32-bit unsigned integer type indicating the framed IP of the subscriber for which the session is created. IP is in decimal format.
- TIME is a 32-bit unsigned integer type indicating the time when session is created. Time is in number of seconds starting from January 1, 1970.

## Abort Session Answer (ASA)

Command-Code Field	Command Flags Field	Direction	Description
274	'R' bit clear	Access device to server	Sent in response to the ASR. The Result-Code AVP <i>must</i> be present; it indicates the disposition of the request.

**Message Format:**

```
<ASA> ::= < Diameter Header: 274, PXY >
         < Session-Id >
         { Result-Code }
         { Origin-Host }
         { Origin-Realm }
         [ Error-Message]
```

**Message Response:**

- Origin-Host is set to the SCE host ID (its IP).
- Origin-Realm is set to the SCE realm.
- Error-Message is set to error description if the SCE is unable to comply.
- The Result-Code is set as follows:
  - If the session identified by Session-Id in the ASR was successfully terminated, Result-Code is set to DIAMETER\_SUCCESS.
  - If the session is not currently active, Result-Code is set to DIAMETER\_UNKNOWN\_SESSION\_ID.
  - If the access device does not stop the session for any other reason, Result-Code is set to DIAMETER\_UNABLE\_TO\_COMPLY.
- The SCE tries to comply only in Pull mode.

**Sample Message:**

```

Version          = 1
Message Length  = XXX
Command Flags   = REQ, PXY
Command Code    = Re-Auth-Request (274)
Application Id  = 16777238
AVPs
  Session-Id    = "27; 3232262425; 1311857000"
  Result-Code   = DIAMETER_SUCCESS
  Origin-Host   = "SCE Host"
  Origin-Realm  = "SCE Realm"

```

The format of the Session-Id is "pid; ip; time", where:

- PID is a 32-bit integer type indicating the unique PID for a specific Gx session.
- IP is a 32-bit unsigned integer type indicating the framed IP of the subscriber for which the session is created. IP is in decimal format.
- TIME is a 32-bit unsigned integer type indicating the time when session is created. Time is in number of seconds starting from January 1, 1970.

**Error Handling:**

- DIAMETER\_UNKNOWN\_SESSION\_ID is returned if no such session id exists in the SCE database.
- DIAMETER\_UNABLE\_TO\_COMPLY is returned when ASR is received in the middle of ending a session (CCR-T was sent). It is also returned when the SCE fails to logout the subscriber for an unknown reason.

# Gy-Supported Messages

The following messages are supported on the Gy interface:

**Supported Gx RLS9 Messages and AVPs**—Used between the SCE and the OCS to request credit authorization for a given service.

**Credit Control Request (CCR)**—The CCR message indicates diameter session create, update, and close.

**Credit Control Answer (CCA)**—Used between the credit-control server and the SCE to acknowledge a Credit-Control-Request command. The SCE listens to the CCA messages and updates the SCA BB with quota grants, failure conditions, and result codes. The CCA message is also used for failure indication and failure handling.

**Re-Authorize Request (RAR)**—Sent by any server to the access device that is providing session service, to request that the user be reauthenticated or be reauthorized. In the SCE Gy implementation, RAR messages are used by the OCS to request usage information on either a specific bucket-id or all buckets. The SCE listens to RAR messages and signals SCA BB to send usage information to the OCS. RAR messages arrive in an asynchronous manner from the server and with no correlation to any request completed by the SCE.

**Re-Authorize Answer (RAA)**—Sent in response to the RAR message. The Result-Code AVP must be present and indicate the disposition of the request. A successful RAA message must be followed by an application-specific authentication and/or authorization message. This message is sent by the Gy application in response to RAR right after the SCA BB is notified that a RAR message has been received.

## Credit Control Request (CCR)

Command-Code Field	Command Flags Field	Direction	Description
272	'R' bit set	SCE to OCS	Sent to request credit authorization for a given service.

The Auth-Application-Id value is set to 4, indicating the Diameter credit-control application.

Table 1-1 lists the CCR message structure.

**Table 1-1 CCR Message Structure**

AVP Name	Category	AVP Code (Code / Vendor-id)	Value	Comment
Session-Id	M <sup>1</sup>	263	String Format: <pid; ip; time>	Session-Id.
Origin-Host	M	264	DiameterIdentifier	IP of the SCE platform.
Origin-Realm	M	296	DiameterIdentifier	Configured value.
Destination-Realm	M	283	DiameterIdentifier	Configured value in CCR (Initial). For subsequent CCRs, the Origin-Realm received in the last CCA is used as Destination-Realm.

Table 1-1 CCR Message Structure (continued)

AVP Name	Category	AVP Code (Code / Vendor-id)	Value	Comment
Destination-Host	Oc <sup>2</sup>	293	DiameterIdentifier	Not sent in the first CCR message. The Origin-Host in the CCA is used as Destination-Host in the next CCR message.
Auth-Application-Id	M	258	4	Value for DCCA.
Service-Context-Identifier	M	461	—	—
CC-Request-Type	M	416	1 = INITIAL_REQUEST 2 = UPDATE_REQUEST 3 = TERMINATION_REQUEST 4 = EVENT_REQUEST	Type “EVENT_REQUEST” is not supported.
CC-Request-Number	M	415	A monotonically increasing number	Value of “0” is used for CCR (INITIAL_REQUEST).
Event-Timestamp	Oc	55	Time when quota is requested	—
Subscription-Id	Om <sup>3</sup>	443	Grouped AVP	Grouped AVP consisting of Subscription-Id-Type and Subscription-Id-Data.
Subscription-Id-Type	Om	450	END_USER_E164 (0)	—
Subscription-Id-Data	Om	444	MSISDN (string)	—
Termination-Cause	Oc	295	Integer value (as per RFC 3588)	Only sent in CCR (FINAL)
Multiple-Services-Indicator	Om	455	MULTIPLE_SERVICES_SUPPORTED (1)	Present only in CCR (INITIAL)
Multiple-Services-Credit-Control (see separate description for <a href="#">Multiple Services Credit Control AVP</a> )	Om	456	Grouped AVP	See <a href="#">Multiple Services Credit Control AVP</a> . Multiple of these attributes can be present. Contains the usage for each category.
Service-Information AVP	Om	—	Grouped AVP	—
PS-Information	Om	—	Grouped AVP	—
Called-Station-Id	Oc	30	APN name (string)	In PS-Information.
SGSN-Address	Oc	1228	IPv4 Address	Subscriber attributes.



Table 1-1 CCR Message Structure (continued)

AVP Name	Category	AVP Code (Code / Vendor-id)	Value	Comment
3GPP-GPRS-QoS-Negotiated-profile	Oc	5/10415	Negotiated QoS profile	QoS profile of the Primary PDP context will be sent. However, if a primary PDP is deleted before the secondary PDPs, subsequent CCR messages contain the negotiated QoS of the first Secondary PDP context. (Subscriber attributes, received from Gx or SCE subscriber API) (in PS-Information).
3GPP-SGSN-MCC-MNC	Oc	18/10415	—	Subscriber attributes, received from Gx or SCE subscriber API (in PS-Information).
3GPP-Charging-Characteristics	Oc	13/10415	Charging Char received from SGSN	—

1. This parameter is mandatory and must be present in the event/CDR.
2. This is a parameter that, if provisioned by the operator to be present, is included in the events/CDRs when the specified conditions are met. In other words, an Oc parameter that is configured to be present is a conditional parameter.
3. This is a parameter that, if provisioned by the operator to be present, is included in the events/CDRs. In other words, an Om parameter that is provisioned to be present is a mandatory parameter.

## CCR Message Formats

This section contains:

- [CCR Initial Message Fields, page 1-18](#)
- [CCR Update Message Fields, page 1-19](#)
- [CCR Final Message Fields, page 1-20](#)

## CCR Initial Message Fields

```

<Credit-Control-Request> ::= < Session-Id >
    { Origin-Host }
    { Origin-Realm }
    { Destination-Realm }
    { Auth-Application-Id }
    { Service-Context-Id }
    { CC-Request-Type }
    { CC-Request-Number }
    [ Event-Timestamp ]
    *[ Subscription-Id ]
        { Subscription-Id-Type }
        { Subscription-Id-Data }
    [ Multiple-Services-Indicator ]
    *[ Multiple-Services-Credit-Control ]
        [ Requested-Service-Unit ]
        *[ Service-Identifier ]
        [ Rating-Group ]
        [ Service-Information ]
            [ PS-Information ]
                [3GPP-GGSN-Address]
                [3GPP-SGSN-Address]
                [3GPP-Charging-Id]
                [Called-Session-Id]
                [3GPP-GPRS-QoS-Negotiated-Profile]
                [3GPP-PDP-Type]
                [3GPP-SGSN-MCC-MNC]
                [3GPP-GGSN-MCC-MNC]
                [3GPP-Charging-Characteristics]
                [3GPP-RAT-Type]
                [3GPP-Selection-Mode]
                [3GPP-NSAPI]
                [3GPP-MS-Timezone]
                [3GPP-User-Location-Info]
            [Acct-Multi-Session-ID]
            [Acct-Session-ID]
            [Acct-Session-Time]
            [Calling-Station-ID]
            [Class]
            [CUI]
            [Framed-IP-Address]
            [NAS-Identifier]
            [NAS-IP-Address]
            [NAS-Port-Type]
            [User-Name]
            [3GPP-GGSN-Address-Code-7]
            [3GPP-IMEISV]
            [3GPP-IMSI]
            [3GPP-CG-Address]
            [3GPP-SGSN-Address-Code-6]
            [WiMax-Active-Time]
            [WiMax-BSID]

```

## CCR Update Message Fields

```

<Credit-Control-Request> ::= < Session-Id >
    { Origin-Host }
    { Origin-Realm }
    { Destination-Realm }
    { Auth-Application-Id }
    { Service-Context-Id }
    { CC-Request-Type }
    { CC-Request-Number }
    [ Destination-Host ]
    [ Event-Timestamp ]
    *[ Subscription-Id ]
        { Subscription-Id-Type }
        { Subscription-Id-Data }
    *[ Multiple-Services-Credit-Control ]
        *[ Used-Service-Unit ]
            [ Tariff-Change-Usage ]
            [ CC-Time ]
            [ CC-Total-Octets ]
            [ CC-Service-Specific-Units ]
            [ Reporting-Reason ]
            [ CC-Input-Octets ]
            [ CC-Output-Octets ]
        *[ Service-Identifier ]
            [ Rating-Group ]
    [ Service-Information ]
        [PS-Information ]
            [3GPP-GGSN-Address]
            [3GPP-SGSN-Address]
            [3GPP-Charging-Id]
            [Called-Session-Id]
            [3GPP-GPRS-QoS-Negotiated-Profile]
            [3GPP-PDP-Type]
            [3GPP-SGSN-MCC-MNC]
            [3GPP-GGSN-MCC-MNC]
            [3GPP-Charging-Characteristics]
            [3GPP-RAT-Type]
            [3GPP-Selection-Mode]
            [3GPP-NSAPI]
            [3GPP-MS-Timezone]
            [3GPP-User-Location-Info]
        [Acct-Multi-Session-ID]
        [Acct-Session-ID]
        [Acct-Session-Time]
        [Calling-Station-ID]
        [Class]
        [CUI]
        [Framed-IP-Address]
        [NAS-Identifier]
        [NAS-IP-Address]
        [NAS-Port-Type]
        [User-Name]
        [3GPP-GGSN-Address-Code-7]
        [3GPP-IMEISV]
        [3GPP-IMSI]
        [3GPP-CG-Address]
        [3GPP-SGSN-Address-Code-6]
        [WiMax-Active-Time]
        [WiMax-BSID]

```

## CCR Final Message Fields

```

<Credit-Control-Request> ::= < Session-Id >
    { Origin-Host }
    { Origin-Realm }
    { Destination-Realm }
    { Auth-Application-Id }
    { Service-Context-Id }
    { CC-Request-Type }
    { CC-Request-Number }
    [ Destination-Host ]
    [ Event-Timestamp ]
    *[ Subscription-Id ]
        { Subscription-Id-Type }
        { Subscription-Id-Data }
    [ Termination-Cause ]
    *[ Multiple-Services-Credit-Control ]
        *[ Used-Service-Unit ]
            [ Tariff-Change-Usage ]
            [ CC-Time ]
            [ CC-Total-Octets ]
            [ CC-Service-Specific-Units ]
            [ Reporting-Reason ]
            [ CC-Input-Octets ]
            [ CC-Output-Octets ]
        *[ Service-Identifier ]
            [ Rating-Group ]

```

## Credit Control Answer (CCA)

Command-Code Field	Command Flags Field	Direction	Description
272	'R' bit cleared	Credit control server to SCE.	Sent to acknowledge a CCR command.

The SCE listens to CCA messages and updates SCA BB with grant quotas, failure conditions, and result codes. CCA is also used for failure indication and failure handling.

Table 1-2 lists the CCA message structure.

**Table 1-2 CCA Message Structure**

AVP name	Category	AVP Code (Code / Vendor-Id)	Value	Comment
Session-Id	M <sup>1</sup>	263	String	
Origin-Host	M	264	DiameterIdentifier	Address of the DCCA server.
Origin-Realm	M	296	DiameterIdentifier	Realm of the DCCA server.
Result-Code	M	268	Integer value (as per RFC 3588 & DCCA draft)	—
Auth-Application-Id	M	258	4	Value for DCCA.

Table 1-2 CCA Message Structure (continued)

AVP name	Category	AVP Code (Code / Vendor-Id)	Value	Comment
CC-Request-Type	M	416	1 = INITIAL_REQUEST 2 = UPDATE_REQUEST 3 = TERMINATION_REQUEST 4 = EVENT_REQUEST	Value 4 (Event) is not supported.
CC-Request-Number	M	415	Same as the one sent in corresponding CCR message	—
CC-Session-Failover	Oc <sup>2</sup>	—	—	—
Multiple-Services-Credit-Control	Om <sup>3</sup>	456	Grouped AVP	Contains the quota granted. There can be multiple instances of this attribute, one for each category.
Service-Context-Id	Oc	—	—	—
Subscription-Id	Oc	—	—	—
CC-Failure-Handling	Oc	—	—	—
Failed-AVP	Oc	279	Grouped AVP. Contains the list of attributes causing failure condition	Optionally present. If the Result-Code is not SUCCESS. There can be multiple instances of this AVP.

1. This parameter is mandatory and must be present in the event/CDR.
2. This is a parameter that, if provisioned by the operator to be present, is included in the events/CDRs when the specified conditions are met. In other words, an Oc parameter that is configured to be present is a conditional parameter.
3. This is a parameter that, if provisioned by the operator to be present, is included in the events/CDRs. In other words, an Om parameter that is provisioned to be present is a mandatory parameter.

## CCA Message Format

```

<Credit-Control-Answer> ::= < Session-Id >
                             { Result-Code }
                             { Origin-Host }
                             { Origin-Realm }
                             { Auth-Application-Id }
                             { CC-Request-Type }
                             { CC-Request-Number }
                             [ CC-Session-Failover ]
                             *[ Multiple-Services-Credit-Control ]
                               [ Granted-Service-Unit ]
                                 [ Tariff-Time-Change ]
                                 [ CC-Time ]
                                 [ CC-Total-Octets ]
                                 [ CC-Input-Octets ]
                                 [ CC-Output-Octets ]
                                 [ CC-Service-Specific-Units ]
                               *[ Service-Identifier ]
                                 [ Rating-Group ]
                                 [ Validity-Time ]
                                 [ Result-Code ]
                                 [ Final-Unit-Indication ]
                                   { Final-Unit-Action }
                                 [ Time-Quota-Threshold ]
                                 [ Volume-Quota-Threshold ]
                                 [ Unit-Quota-Threshold ]
                                 [ Quota-Holding-Time ]
                                 [ Quota-Consumption-Time ]
                                 [ Service-Context-Id ]
                               *[ Subscription-Id ]
                                 { Subscription-Id-Type }
                                 { Subscription-Id-Data }
                                 [ Credit-Control-Failure-Handling ]
                                 [ CC-Session-Failover ]
                               *[ Failed-AVP ]

```

## Re-Auth Request (RAR)

Command-Code Field	Command Flags Field	Direction	Description
258	'R' bit set	Server to access device	Sent to the access device that is providing session service to request that the user be reauthenticated or reauthorized.

In the SCE, Gy implementation of RAR messages may be used by the OCS to request usage information about a specific bucket-id or about all the buckets. The SCE listens to the RAR messages and signals the SCA BB to send usage information to the OCS.

RAR messages may arrive asynchronously from the server, with no correlation to any request from the SCE. The SCE behavior upon receiving an RAR message is common to other scenarios as well, such as logout or package change.

Table 1-3 lists the RAR message structure.

**Table 1-3 RAR Message Structure**

AVP Name	Category	AVP Code (Code/Vendor Id)	Value	Comment
Session-Id	M <sup>1</sup>	263	String	—
Origin-Host	M	264	Host name of Diameter server	—
Origin-Realm	M	296	Origin realm of Diameter server	—
Destination-Realm	M	283	Destination realm of diameter peer	—
Destination-Host	M	293	Host name of diameter peer	—
Auth-Application-Id	M	258	4	—
Re-Auth-Request-Type	M	285	Authorize-Only	—
Rating-Group	Oc <sup>2</sup>	432	Category Id	Presence of this AVP means that reauthorization is done for this specific category.

1. This parameter is mandatory and must be present in the event/CDR.
2. This is a parameter that, if provisioned by the operator to be present, is included in the events/CDRs when the specified conditions are met. In other words, an Oc parameter that is configured to be present is a conditional parameter.

## RAR Message Format

```
<Re-Auth-Request> ::= < Session-Id >
                        { Origin-Host }
                        { Origin-Realm }
                        { Destination-Realm }
                        { Destination-Host }
                        { Auth-Application-Id }
                        { Re-Auth-Request-Type }
                        [ Rating-Group ]
```

## Re-Auth Answer (RAA)

Command-Code Field	Command Flags Field	Direction	Description
258	'R' bit cleared	Access device to server	Sent in response to the RAR.

The Result-Code AVP *must* be present, and indicates the disposition of the request.

A successful RAA message *must* be followed by an application-specific authentication, authorization message, or both.

This message is sent by the Gy application in response to RAR right after the SCA BB is notified with the RAR.

Table 1-4 lists the RAA message structure.

**Table 1-4 RAA Message Structure**

AVP Name	Category	AVP Code (Code/Vendor Id)	Value	Comment
Session-Id	M <sup>1</sup>	263	String, Format: <pid; ip; time>	—
Result-Code	M	268	2001, 2002	A value of 2001 is sent if no CCR (Update) is sent. A value of 2002 is sent if a subsequent CCR (Update) follows.
Origin-realm	M	296	DiameterIdentifier	Configured value.
Origin-Host	M	264	DiameterIdentifier	Configured value.

1. This parameter is mandatory and must be present in the event/CDR.

## RAA Message Format

```
<Re-Auth-Answer> ::= < Session-Id >
                    { Origin-Host }
                    { Origin-Realm }
                    { Result-Code }
```

## Supported Gy Messages and AVPs

Table 1-5 lists the Gy messages and the AVPs used for Gy client interface support.

**Table 1-5 Supported Gy Messages and AVPs**

Messages						Gy Message Fields	Category	Comment
CCR Initial	CCR Update	CCR Termination	CCA	RAR	RAA	—	—	—
+	+	+	+	+	+	Session-Id	M <sup>1</sup>	—
—	—	—	+	—	+	Result-Code	M	—
+	+	+	+	+	+	Origin-Host	M	—
+	+	+	+	+	+	Origin-Realm	M	—
+	+	+	—	+	—	Destination-Realm	M	—
+	+	+	+	+	—	Auth-Application-Id	M	—
—	—	—	—	+	—	Re-Auth-Request-Type	M	—
+	+	+	—	—	—	Service-Context-Identifier	M	—
+	+	+	+	—	—	CC-Request-Type	M	—
+	+	+	+	—	—	CC-Request-Number	M	—
—	—	—	+	—	—	CC-Session-Failover	Oc <sup>2</sup>	—



Table 1-5 Supported Gy Messages and AVPs (continued)

Messages						Gy Message Fields	Category	Comment
CCR Initial	CCR Update	CCR Termination	CCA	RAR	RAA	—	—	—
—	—	—	—	+	—	Destination-Host	Oc (M for RAR)	—
—	—	—	—	(+)	—	Rating-Group	Oc	—
+	+	+	—	—	—	Event-Timestamp	Om <sup>3</sup>	—
+	+	+	—	—	—	Subscription-Id	Om	Grouped AVP
+	+	+	—	—	—	Subscription-Id-Type	Om	—
+	+	+	—	—	—	Subscription-Id-Data	Oc	—
—	—	+	—	—	—	Termination-Cause	Om	Reporting reason is used for regular logout, unsupported tariff-change, and unsupported unit type.
+	—	—	—	—	—	Multiple-Services-Indicator	Om	—
+	+	+	+	—	—	Multiple-Services-Credit-Control	Om	Grouped AVP
+	+	+	—	—	—	Service-Identifier	—	—
+	—	—	—	—	—	Requested-Service-Unit	Oc	Empty
—	+	+	—	—	—	Used-Service-Unit	Oc	Grouped AVP
—	+	+	—	—	—	Reporting-Reason	Oc	—
—	+	+	—	—	—	Tariff-Change-Usage	Oc	—
—	+	+	—	—	—	CC-Time	Oc	—
—	+	+	—	—	—	CC-Total-Octets	Oc	—
—	+	+	—	—	—	CC-Input-Octets	Oc	—
—	+	+	—	—	—	CC-Output-Octets	Oc	—
—	+	+	—	—	—	CC-Service-Specific-Units	Oc	—
—	—	—	+	—	—	Granted-Service-Unit	Oc	Grouped AVP
—	—	—	+	—	—	Tariff-Time-Change	Oc	—
—	—	—	+	—	—	CC-Time	Oc	—
—	—	—	+	—	—	CC-Total-Octets	Oc	—
—	—	—	+	—	—	CC-Input-Octets	Oc	—
—	—	—	+	—	—	CC-Output-Octets	Oc	—
—	—	—	+	—	—	CC-Service-Specific-Units	Oc	—
(+)	+	+	+	—	—	Rating-Group	Oc	—

Table 1-5 Supported Gy Messages and AVPs (continued)

Messages						Gy Message Fields	Category	Comment
CCR Initial	CCR Update	CCR Termination	CCA	RAR	RAA	—	—	—
—	—	—	+	—	—	Validity-Time	Oc	—
—	—	—	+	—	—	Result-Code	Oc	Considered only if the Result-Code value present at the command level is SUCCESS. The value is defined by 3GPP TS 32.299 V6.6.0 section 7.15.
—	—	—	+	—	—	Final-Unit-Indication	Oc	Grouped AVP
—	—	—	+	—	—	Final-Unit-Action	Oc	TERMINATE, REDIRECT, or RESTRICT_ACCESS
—	—	—	+	—	—	Time-Quota-Threshold	Oc	—
—	—	—	+	—	—	Volume-Quota-Threshold	Oc	—
—	—	—	+	—	—	Unit-Quota-Threshold	Oc	—
—	—	—	+	—	—	Quota-Holding-Time	Oc	—
—	—	—	+	—	—	Quota-Consumption-Time	Oc	—
—	—	—	+	—	—	Credit-Control-Failure-Handling	—	—
+	—	—	—	—	—	Service-Information AVP	Om	Grouped AVP
+	—	—	—	—	—	PS-Information	Om	Grouped AVP
+	—	—	—	—	—	Called-Station-Id	Om	—
+	—	—	—	—	—	SGSN-Address	Om	—
+	—	—	—	—	—	3GPP-GPRS-Negotiated-QOS-Profile	Om	—
+	—	—	—	—	—	3GPP-SGSN-MCC-MNC	Om	—
+	—	—	—	—	—	3GPP-Charging-Characteristics	Om	—

1. This parameter is mandatory and must be present in the event/CDR.
2. This is a parameter that, if provisioned by the operator to be present, is included in the events/CDRs when the specified conditions are met. In other words, an Oc parameter that is configured to be present is a conditional parameter.
3. This is a parameter that, if provisioned by the operator to be present, is included in the events/CDRs. In other words, an Om parameter that is provisioned to be present is a mandatory parameter.

# Multiple Services Credit Control AVP

The Multiple Services Credit Control (MSCC) AVP is used for granting and reporting quota for each bucket (rating-group). [Figure 1-2](#) illustrates the structure of this attribute, and [Table 1-6](#) lists the structure.

When the MSCC AVP is present in CCA messages, it represents quota being granted. When it is present in CCR messages, it represents usage being reported. If quota/usage is being reported for more than one rating-group, then multiple MSCC AVPs are present in the message.

There are some attributes that can be present at the command level and the MSCC level.

- **Result-Code**  
If the Result-Code present at the command level is SUCCESS, the Result-Code present at MSCC level takes effect.
- **Validity-Time**  
The Validity-Time present at the command level applies to all the categories. If Validity-Time is present at MSCC level, its value is used for that particular category.
- **Requested-Service-Unit**  
This AVP must be present at the command level for CCR (initial). When the quota request for a particular category is made using CCR (update), it is present at the MSCC level for that category.

**Figure 1-2 MSCC AVP Structure**

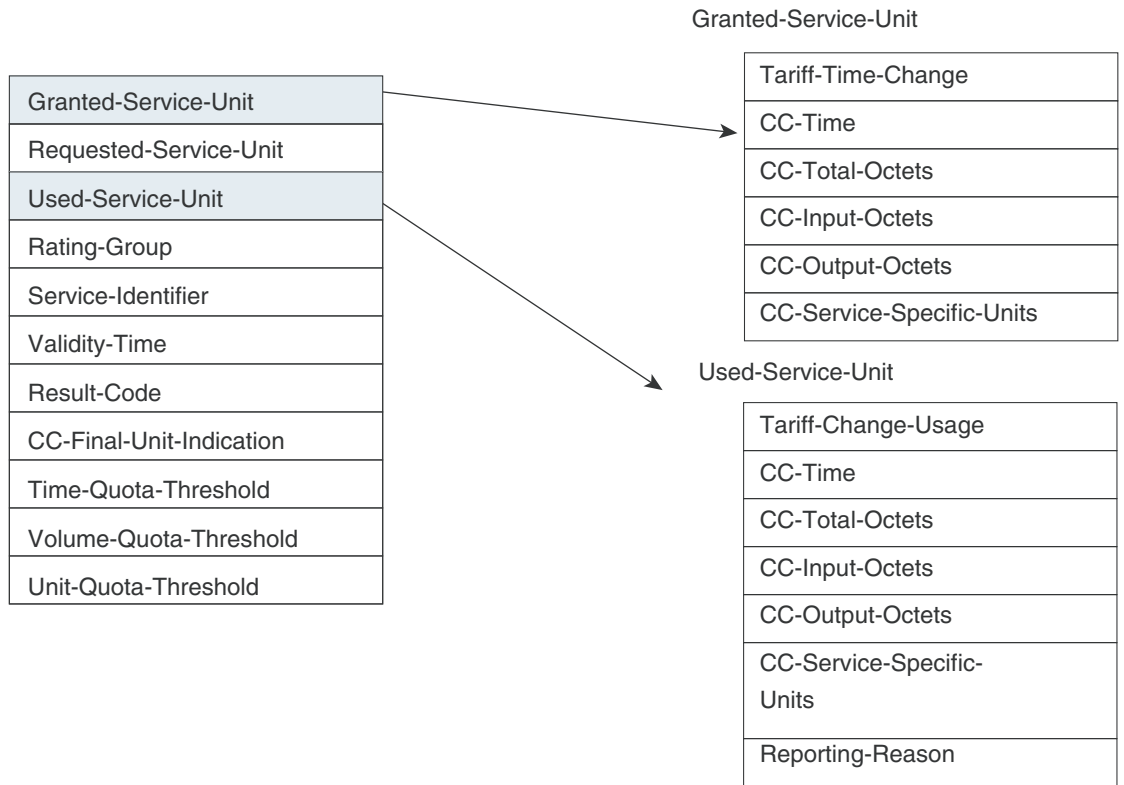

277077

Table 1-6 MSCC AVP Structure

AVP Name	Category	AVP Code (Code / Vendor-Id)	Value	Comment
Granted-Service-Unit	Oc <sup>1</sup>	431	Grouped AVP	Present inside MSCC of a CCA (initial) and CCA (update) message.
Requested-Service-Unit	Oc	437	Empty value	Conditionally present inside MSCC of a CCR (update) message.
Used-Service-Unit	Oc	446	Grouped AVP	Present inside MSCC of a CCR (update) and CCR (final) message. There can be multiple instances of this AVP.
Rating-Group	Oc	432	—	Used to indicate service.
Validity-Time	Oc	448	Time until quota is valid	A value of “0” is considered invalid. Present inside MSCC of CCA messages.
Result-Code	Om <sup>2</sup>	268	Value as per DCCA RFC	Considered only if the Result-Code value present at command level is SUCCESS. Present inside MSCC of CCA messages.
CC-Final-Unit-Indication	Oc	—	Grouped AVP	—
Final Unit Indication	Oc	—	—	—
Time-Quota-Threshold	Oc	868/10415	Quota threshold for time quota in seconds	Present inside MSCC of CCA messages. This AVP is ignored if no time quota is granted (that is, CC-Time AVP is not present inside Granted-Service-Unit AVP).
Volume-Quota-Threshold	Oc	869/10415	Quota threshold for volume quota in octets	Present inside MSCC of CCA messages. This AVP is ignored if no volume quota is granted (that is, CC-Total-Octets is not present inside Granted-Service-Unit AVP).
Unit-Quota-Threshold	Oc	869/10415	Quota threshold for unit quota in octets	Present inside MSCC of CCA messages. This AVP is ignored if no unit quota is granted (i.e. CC-Unit-Quota is not present inside Granted-Service-Unit AVP).

Table 1-6 MSCC AVP Structure (continued)

AVP Name	Category	AVP Code (Code / Vendor-Id)	Value	Comment
CC-Time	Oc	420	Time quota in seconds	Present in Granted-Service-Unit AVP and Used-Service-Unit AVP.
CC-Service-Specific-Units	Oc	417	Events quota	Refer to the service identified in the Service-Identifier AVP.
CC-Total-Octets	Oc	421	Volume quota in octets (64 bit number)	Present in Granted-Service-Unit AVP and Used-Service-Unit AVP.
Tariff-Time-Change	Oc	451	Number of seconds since 01/01/1900 UTC	Refer to the time when tariff of the service will be changed. Present in Granted-Service-Unit AVP.
Tariff-Change-Usage	Oc	452	UNIT_BEFORE_TARIFF_CHANGE (0), UNIT_AFTER_TARIFF_CHANGE (1), UNIT_UNDETERMINATE (2)	Present in Used-Service-Unit AVP.
CC-Input-Octets	Oc	412	Number of octets received from the end user	Present in Used-Service-Unit.
CC-Output-Octets	Oc	414	Number of octets sent to the end user	Present in Used-Service-Unit.

1. This is a parameter that, if provisioned by the operator to be present, is included in the events/CDRs when the specified conditions are met. In other words, an Oc parameter that is configured to be present is a conditional parameter.
2. This is a parameter that, if provisioned by the operator to be present, is included in the events/CDRs. In other words, an Om parameter that is provisioned to be present is a mandatory parameter.

# Gy Support Session and Call Flows

This section provides information on Gy support session initiation, quota usage reporting, package changes, and call flows.

## Initiating Session

Once a login event occurs on SCA BB, it sends a Session Creation RDR if the subscriber quota is externally provisioned. The Gy interface listens to these messages and in return sends a CCR initial message to the OCS with or without quota usage information. This process is completed to allow PDP context creation on the OCS as quickly as possible.

[Table 1-7](#) lists the required fields in the CCR initial message and their sources and [Figure 1-3](#) displays the session creation call flow.

**Table 1-7 CCR Initial Message Fields and Sources**

Gy Message Fields	Category	Internal Resource	Internal Interface
—	—	Internal Resource	Session Creation RDR
Session-Id	M <sup>1</sup>	Session ID pool	—
Origin-Host	M	Diameter Config	—
Origin-Realm	M	Diameter Config	—
Destination-Realm	M	Diameter Routing Table	—
Auth-Application-Id	M	Preconfigured	—
Service-Context-Identifier	M	Preconfigured	—
CC-Request-Type	M	—	Reporting-Reason
CC-Request-Number	M	Session context CCR counter	—
Event-Timestamp	Om <sup>2</sup>	System clock	—
Subscription-Id	Om	—	—
Subscription-Id-Type	Om	Preconfigured	—
Subscription-Id-Data	Oc <sup>3</sup>	—	Subscriber id
Multiple-Services-Indicator	Om	Always MULTIPLE_SERVICES_ SUPPORTED (1)	—
Multiple-Services-Credit-Control	Om	—	—
Service-Identifier	—	—	—
Requested-Service-Unit	Oc	—	—
Rating-Group	Oc	—	Bucket-id
Service-Information AVP	Om	—	—
PS-Information	Om	—	—
Called-Station-Id	Om	Subscriber's attributes	—
SGSN-Address	Om	Subscriber's attributes	—

**Table 1-7 CCR Initial Message Fields and Sources (continued)**

Gy Message Fields	Category	Internal Resource	Internal Interface
—	—	<b>Internal Resource</b>	<b>Session Creation RDR</b>
3GPP-GPRS-Negotiated-QOS-Profile	Om	Subscriber's attributes	—
3GPP-SGSN-MCC-MNC	Om	Subscriber's attributes	—
3GPP-Charging-Characteristics	Om	Subscriber's attributes	—

1. This parameter is mandatory and must be present in the event/CDR.
2. This is a parameter that, if provisioned by the operator to be present, is included in the events/CDRs. In other words, an Om parameter that is provisioned to be present is a mandatory parameter.
3. This is a parameter that, if provisioned by the operator to be present, is included in the events/CDRs when the specified conditions are met. In other words, an Oc parameter that is configured to be present is a conditional parameter.

**Figure 1-3 Session Creation**

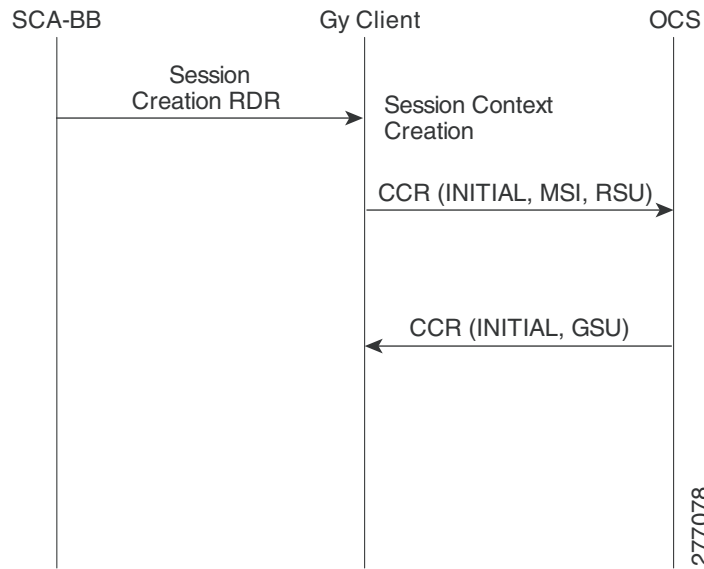

## Reporting Quota Usage

The SCE reports the quota usage for each category under the circumstances listed in [Table 1-8](#).

**Table 1-8** Quota Reporting Usage Conditions and Reasons

Condition	Reporting Reason
Threshold hit	THRESHOLD
Quota breach	QUOTA_EXHAUSTED
Quota Holding Timer expired	QHT
Validity Timer expired	VALIDITY_TIME
Package Change	RATING_CONDITION_CHANGE (TERMINATE and INITIAL)
Server initiated reauthorization procedure	FORCED_REAUTHORIZATION

Quota usage is reported by SCA BB using the Quota Status RDR, the Gy client listens to these messages and delivers them by a CCR update message to the OCS.

[Table 1-9](#) lists the structure of a CCR update message and the source for each field and [Figure 1-4](#) displays the quota usage update call flow.

**Table 1-9** CCR Update Message Structure

Gy Message Fields	Category	Internal Resource	Internal Interface Quota Status RDR
Session-Id	M <sup>1</sup>	Session ID pool	—
Origin-Host	M	Diameter Config	—
Origin-Realm	M	Diameter Config	—
Destination-Realm	M	Diameter Routing Table	—
Auth-Application-Id	M	Preconfigured	—
Service-Context-Identifier	M	Preconfigured	—
CC-Request-Type	M	—	Reporting-Reason
CC-Request-Number	M	Session context CCR counter	—
Event-Timestamp	Om <sup>2</sup>	System clock	—
Subscription-Id	Om	—	—
Subscription-Id-Type	Om	Preconfigured	—
Subscription-Id-Data	Oc <sup>3</sup>	—	Subscriber id
Multiple-Services-Credit-Control	Om	—	—
Service-Identifier	—	—	—
Rating-Group	Oc	—	Bucket-id
Used-Service-Unit	Oc	—	—
Reporting-Reason	Oc	—	Reporting-Reason
Tariff-Change-Usage	Oc	—	Tarrif-Change-Usage

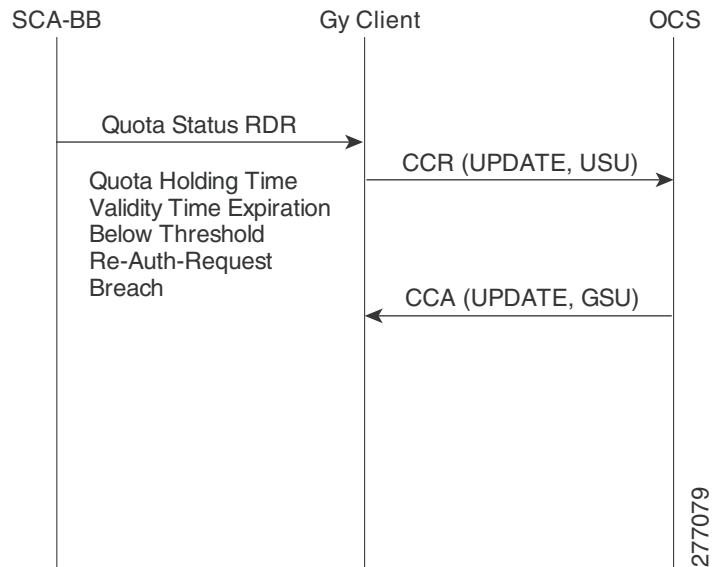

**Table 1-9 CCR Update Message Structure (continued)**

Gy Message Fields	Category	Internal Resource	Internal Interface Quota Status RDR
CC-Time	Oc	—	Units-Type +Unit-Amount
CC-Total-Octets	Oc	—	Units-Type + Unit-Amount
CC-Input-Octets	Oc	—	Units-Type + Unit-Amount
CC-Output-Octets	Oc	—	Units-Type + Unit-Amount
CC-Service-Specific-Units	Oc	—	Units-Type + Unit-Amount

1. This parameter is mandatory and must be present in the event/CDR.
2. This is a parameter that, if provisioned by the operator to be present, is included in the events/CDRs. In other words, an Om parameter that is provisioned to be present is a mandatory parameter.
3. This is a parameter that, if provisioned by the operator to be present, is included in the events/CDRs when the specified conditions are met. In other words, an Oc parameter that is configured to be present is a conditional parameter.

**Figure 1-4 Quota Usage Update**



The exact structure of CCR update is also used for CCR terminate. Figure 1-5 displays the session termination initiated by the SCA BB call flow. Figure 1-6 displays the reauthorization request initiated by the OCS.

**Figure 1-5 Session Termination Initiated by SCA BB**

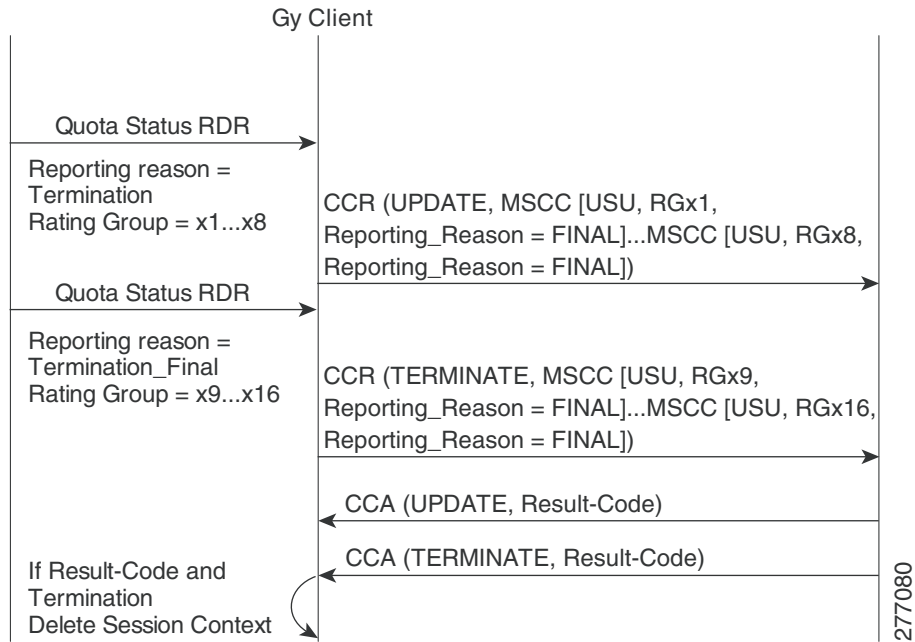

**Figure 1-6 Reauthorization Request Initiated by the OCS**

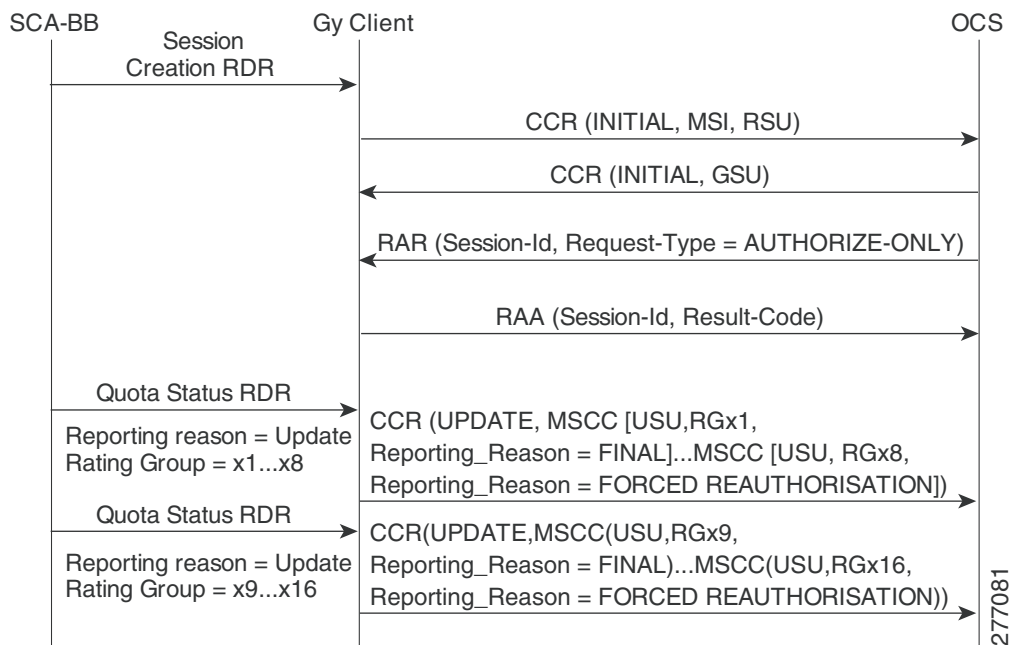

# Package Change

Upon package change, the SCA BB sends a Session Termination RDR, which contains the final indication and usage reporting on all the buckets and the reporting reason of the pre-package. As a result, the Gy interface sends a CCR final message with usage information. After this, the SCA BB sends a Quota Status RDR with reporting reason of postpackage, the Gy client issues a CCR initial message with bucket IDs. Figure 1-7 displays the tariff change call flow and Figure 1-8 displays the package change call flow.

**Figure 1-7 Tariff Change**

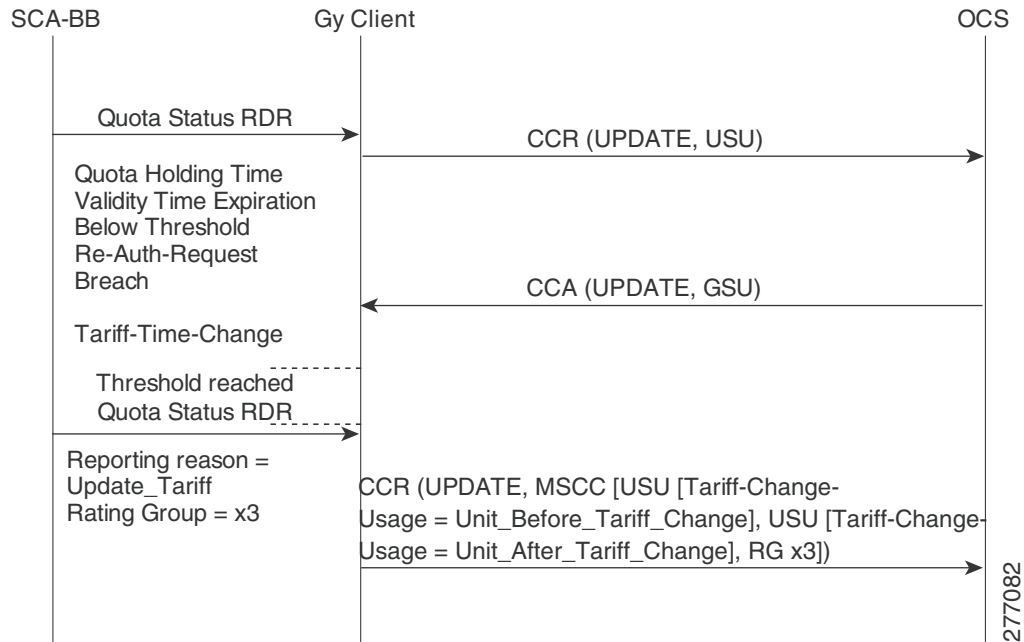
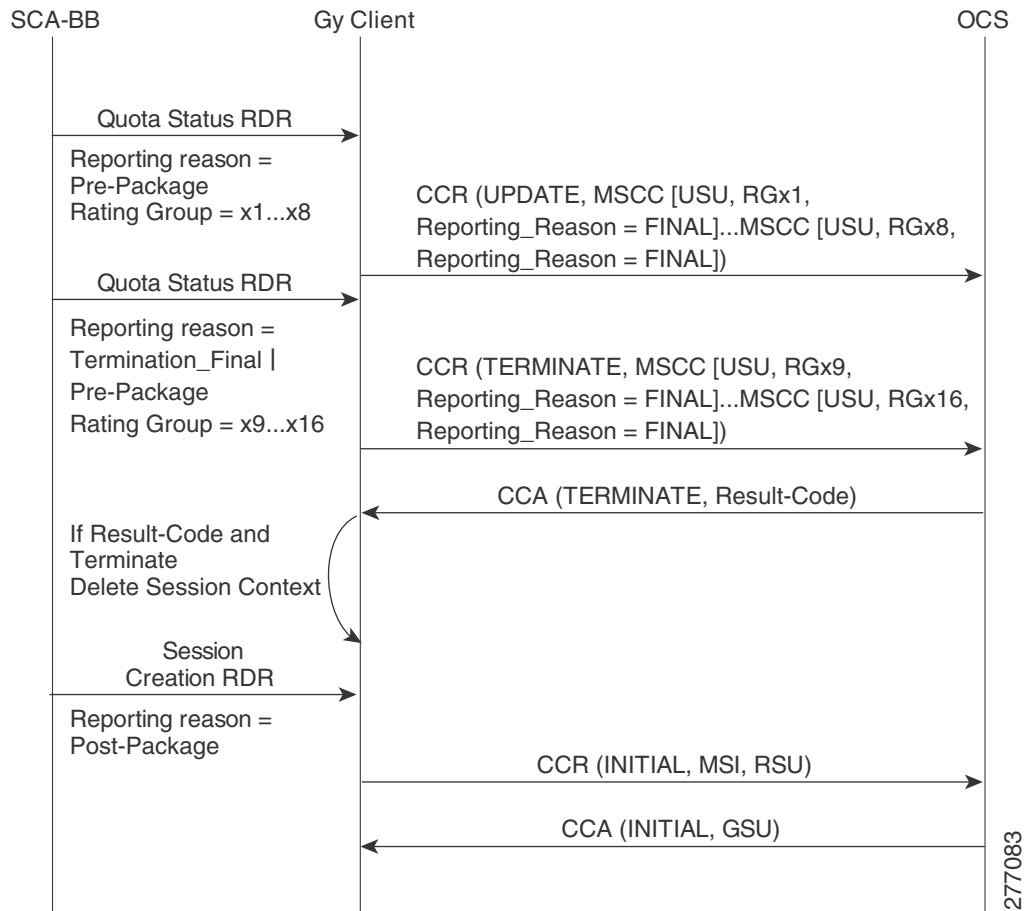

Figure 1-8 Package Change

**Note**

The SCE immediately forwards messages from the data plane to OCS without buffering it. It does not wait to receive the CCA message from OCS before sending the next message. Robust OCS implementation should be able to cope with receiving the CCR-U message from the SCE before the CCA-I message was sent and receiving the CCR-T message before the CCA-U message was sent.

## supported Gx RLS9 Messages and AVPs

Table 1-10 summarizes the message types and AVPs that Gx RLS9 supports.

**Table 1-10** Supported Gx RLS9 Messages and AVPs

AVP Name	AVP Code (Code / Vendor-Id)	Value Type	Value	Comment
Event-Trigger	1006/ 10415 (3GPP)	Enumerated	USAGE_REPORT (26)—PCRF provides the Usage-Monitoring- Information AVP.	Used in CCA or RAR messages to enable event triggering.
Monitoring-Key	1066/ 10415	OctetString	SCE bucket ID	Identifies the monitoring control instance (bucket) that Usage-Monitoring-Infoma tion AVP refers to.  Present in the Usage-Monitoring-Infoma tion AVP.
Usage-Monitoring-Infoma tion	1067/ 10415	Grouped	Grouped AVP	Appears when the Event-Trigger AVP is set to USAGE_REPORT.
Granted-Service-Unit	431	Grouped	Grouped AVP	Provides the threshold level to the PCEF.  Present in the Usage-Monitoring-Infoma tion AVP.
Used-Service-Unit	446	Grouped	Grouped AVP	Provides the measured usage to the PCRF.  Present in the Usage-Monitoring-Infoma tion AVP.
Usage-Monitoring-Level	1068/ 10415	Enumerated	PCC_RULE_LEVEL (1)	Supports only pre-defined PCC rule.  Present in the Usage-Monitoring-Infoma tion AVP.
Usage-Monitoring-Report	1069/ 10415	Enumerated	Empty value USAGE_MONITORING_ REPORT_REQUIRED (0)	Value of “0” indicates a request from the PCRF for a report of accumulated usage, regardless of whether or not threshold has been reached.  Present in the Usage-Monitoring-Infoma tion AVP.

Table 1-10 Supported Gx RLS9 Messages and AVPs (continued)

AVP Name	AVP Code (Code / Vendor-Id)	Value Type	Value	Comment
Usage-Monitoring-Support	1070/ 10415	Enumerated	USAGE_MONITORING_ DISABLED (0)	Indicates that usage monitoring is disabled for the relevant monitoring key.  Present in the Usage-Monitoring-Information AVP.
CC-Total-Octets	421	Unsigned64	Total volume in bytes (either threshold or actual).	Present in the Granted-Service-Unit AVP and the Used-Service-Unit AVP.
CC-Input-Octets	412	Unsigned64	Uplink volume in bytes (either threshold or actual).	Present in the Granted-Service-Unit AVP and the Used-Service-Unit AVP.
CC-Output-Octets	414	Unsigned64	Downlink volume in bytes (either threshold or actual).	Present in the Granted-Service-Unit AVP and the Used-Service-Unit AVP.

## Usage-Monitoring-Information

The Usage-Monitoring-Information AVP is enabled when the value of the Event-Trigger AVP is USAGE\_REPORT.

The SCE reports the accumulated usage under the following conditions:

- When a usage threshold is reached
- When a package (containing the predefined PCC rules) is changed
- When usage monitoring is explicitly disabled by the PCRF
- When the session is terminated
- When requested by the PCRF (by setting the value of USAGE\_MONITORING\_REPORT\_REQUIRED (0) in the Usage-Monitoring-Report AVP in an RAR or CCA message).

To report, the SCE sends a CCR message as follows:

- CC-Request-Type AVP = "UPDATE\_REQUEST"
- Event-Trigger AVP = "USAGE\_REPORT"
- Usage-Monitoring-Information AVP includes:
  - Monitoring key (SCA BB bucket ID) in the Monitoring-Key AVP
  - The accumulated usage since the last report in the Used-Service-Unit AVP (using CC-Total-Octets, CC-Input-Octets, or CC-Output-Octets).

## Usage-Monitoring-Information AVP Format

```
<Usage-Monitoring-Information> ::= [ Monitoring-Key ]
    [ Grante-Service-Unit ]
        [ CC-Total-Octets ]
        [ CC-Input-Octets ]
        [ CC-Output-Octets ]
        *[ AVP ]
    [ Used-Service-Unit ]
        [ CC-Total-Octets ]
        [ CC-Input-Octets ]
        [ CC-Output-Octets ]
        *[ AVP ]
    [ Usage-Monitoring-Level ]
    [ Usage-Monitoring-Report ]
    [ Usage-Monitoring-Support
```

