



CHAPTER 4

Installing the Cisco SCE8000 Chassis

Revised: June 13, 2011, OL-24137-01

Introduction

This chapter describes how to install a Cisco SCE8000 chassis.


Warning

Only trained and qualified personnel should be allowed to install, replace, or service this equipment.
Statement 1030


Warning

There is the danger of explosion if the battery is replaced incorrectly. The battery is not a user-serviceable part.
Statement 1015


Warning

Class 1 laser product.
Statement 1008


Warning

Because invisible laser radiation may be emitted from the aperture of the port when no cable is connected, avoid exposure to laser radiation and do not stare into open apertures.
Statement 1056


Warning

Blank faceplates and cover panels serve three important functions: they prevent exposure to hazardous voltages and currents inside the chassis; they contain electromagnetic interference (EMI) that might disrupt other equipment; and they direct the flow of cooling air through the chassis. Do not operate the system unless all cards, faceplates, front covers, and rear covers are in place.
Statement 1029



Note

Before you install, operate, or service the system, read the [Regulatory Compliance and Safety Information for the Cisco SCE8000 Platform](#). This guide contains important safety information you should know before working with the system.

**Caution**

Before working on a chassis or working near power supplies, unplug the power cord on AC units; disconnect the power at the circuit breaker on DC units.

**Note**

The plug-socket combination must be accessible at all times because it serves as the main disconnecting device.

**Note**

This unit is intended for installation in restricted access areas. A restricted access area can be accessed only through the use of a special tool, lock and key, or other means of security.

- [Preparing for Installation, page 4-3](#)
- [Installing the Cisco SCE8000 Chassis in the Rack, page 4-15](#)
- [Connecting the System Ground, page 4-20](#)
- [Installing the Power Supplies in the Cisco SCE8000 Chassis, page 4-22](#)

Preparing for Installation

- [Safety, page 4-3](#)
- [Site Requirements, page 4-3](#)
- [Power Connection Guidelines, page 4-5](#)

Safety

**Warning**

Read the installation instructions before connecting the system to the power source.

**Note**

This equipment must be grounded. Never defeat the ground conductor or operate the equipment in the absence of a suitably installed ground conductor. Contact the appropriate electrical inspection authority or an electrician if you are uncertain that suitable grounding is available.

**Note**

This product requires short-circuit (overcurrent) protection, to be provided as part of the building installation. Install only in accordance with national and local wiring regulations.

Site Requirements

This section provides site power requirements for the Cisco SCE8000 chassis. Verify the site power before installation.

- [Preventing Electrostatic Discharge Damage, page 4-3](#)
- [Environmental Requirements, page 4-4](#)
- [Power Requirements, page 4-5](#)

Preventing Electrostatic Discharge Damage

Electrostatic discharge (ESD) damage, which can occur when electronic cards or components are improperly handled, results in complete or intermittent failures. Port adapters and blades consist of printed circuit boards that are fixed in metal carriers. Electromagnetic interference (EMI) shielding and connectors are integral components of the carrier. Although the metal carrier helps to protect the board from ESD, use a preventive antistatic strap during handling.

Following are guidelines for preventing ESD damage:

- Always use an ESD wrist or ankle strap and ensure that it makes good skin contact.
- Connect the equipment end of the strap to an unfinished chassis surface.
- When installing a component, use any available ejector levers or captive installation screws to properly seat the bus connectors in the backplane or midplane. These devices prevent accidental removal, provide proper grounding for the system, and help to ensure that bus connectors are properly seated.

- When removing a component, use any available ejector levers or captive installation screws to release the bus connectors from the backplane or midplane.
- Handle carriers by available handles or edges only; avoid touching the printed circuit boards or connectors.
- Place a removed component board-side-up on an antistatic surface or in a static shielding container. If you plan to return the component to the factory, immediately place it in a static shielding container.
- Avoid contact between the printed circuit boards and clothing. The wrist strap only protects components from ESD voltages on the body; ESD voltages on clothing can still cause damage.
- Never attempt to remove the printed circuit board from the metal carrier.

**Caution**

For safety, periodically check the resistance value of the antistatic strap. The measurement should be between 1 and 10 megohm (Mohm).

Environmental Requirements

Ensure adequate spacing between racks using the information in the following table. Keep all of the vents clear of obstructions, including dust and foreign conductive material, and away from the exhaust ports of other equipment. [Table 4-1](#) lists the chassis airflow requirements, and [Table 4-2](#) lists the Cisco SCE 8000 environmental requirements.

Table 4-1 Chassis Airflow Requirements

Airflow Intake	Airflow Exhaust	Air Filter Option	Minimum Clearance (walls)	Minimum Horizontal Separation
Right side	Left side	Not applicable	6 in (15 cm)	12 in (30.5 cm)

Table 4-2 Ambient Temperature and Humidity Requirements for the Cisco SCE 8000

Specification	Acceptable Range
Temperature	Nominal: 32°F to 104°F (0°C to 40°C) Storage: -4°F to 149°F (-20°C to 65°C)
Relative humidity	Operating: 10% to 85% Storage: 5% to 95% (non-condensing)
Heat dissipation	<ul style="list-style-type: none"> • Single SCE8000-SCM-E module: <ul style="list-style-type: none"> – AC Power: 950 W / 3250 BTUs – DC Power: 1000 W / 3450 BTUs • Dual SCE8000-SCM-E modules: <ul style="list-style-type: none"> – AC Power: 1350 W / 4600 BTUs – DC Power: 1430 W / 4880 BTUs

Power Requirements



Read the installation instructions before connecting the system to the power source.

Follow these requirements when preparing your site for the Cisco SCE8000 installation:

- The redundant power configuration provides a second, identical power supply to ensure that power to the chassis continues uninterrupted if one power supply fails or input power on one line fails.
- Connect each of the two power supplies to a separate input power source. If you fail to do this, your system might be susceptible to total power failure because of a fault in the external wiring or a tripped circuit breaker.
- To prevent a loss of input power, be sure that the total maximum load on each circuit supplying the power supplies is within the current ratings of the wiring and breakers.
- In some systems, you might use an uninterruptible power supply (UPS) to protect against power failures at your site. Avoid UPS types that use ferroresonant technology. These UPS types can become unstable with systems like the Cisco SCE8000, which can have substantial current draw fluctuations because of bursty data traffic patterns.

Power Connection Guidelines

This section provides the guidelines for connecting the Cisco SCE8000 AC and DC power supplies to the site power source.

- [AC-Powered Systems, page 4-5](#)
- [DC-Powered Systems, page 4-12](#)
- [Site Planning Checklist, page 4-14](#)

AC-Powered Systems

- Each chassis power supply should have its own dedicated branch circuit.
- Circuits must be protected by a dedicated two-pole circuit breaker.
 - For North America, the circuit breaker should be rated at 20A.
 - For everywhere else, the circuit breaker should be sized according to the power supply input rating and local or national code requirements.
- AC power receptacles used to plug in the chassis must be the grounding type. The grounding conductors that connect to the receptacles should connect to protective earth ground at the service equipment.



Never defeat the ground conductor or operate the equipment in the absence of a suitably installed ground conductor. Contact the appropriate electrical inspection authority or an electrician if you are uncertain that suitable grounding is available.

**Note**

The plug-socket combination must be accessible at all times because it serves as the main disconnecting device.

**Note**

This product requires short-circuit (overcurrent) protection, to be provided as part of the building installation. Install only in accordance with national and local wiring regulations.

Table 4-3 lists the Cisco SCE 8000 AC power specifications.

Table 4-3 Cisco SCE 8000 AC Power Specifications

Specification	Acceptable Range
PWR-2700-AC/4 minimum capability	1350 W output (1650 W input)
AC-input power consumption	<ul style="list-style-type: none"> Single SCE8000-SCM-E module: 1000 W (8.3 A @ 120 VAC, 4.5 A @ 220 VAC) Dual SCE8000-SCM-E modules: 1600 W (13.3 A @ 120 VAC, 7.27 A @ 220 VAC)
AC-input voltage rating	Low-line (120 VAC nominal)-85 VAC (min) to 132 VAC (max) High-line (230 VAC nominal)-170 VAC (min) to 264 VAC (max)
AC-input current rating	16 A maximum at 120 VAC 16 A maximum at 230 VAC
AC-fusing requirements	For North America, the circuit breaker should be rated at 20 A. For everywhere else, the circuit breaker should be sized according to the input current rating and local or national code requirements.
AC-input frequency rating	50/60 Hz (nominal) ($\pm 3\%$ for full range)

Table 4-4 lists the AC-input power cord options, specifications, and Cisco product numbers for the 2700 W AC-input power supplies. It also references power cord illustrations.

Table 4-4 AC-Input Power Cord Options

Locale	Part Number	Length	Plug Rating	Power Cord Reference Illustration
North America (locking)	CAB-GSR16-US(=)	14 feet (4.3m)	250VAC, 20A	Figure 4-1
Europe	CAB-GSR16-EU(=)	14 feet (4.3m)	250VAC, 16A	Figure 4-1
International	CAB-AC16A-90L-IN(=)	14 feet (4.3m)	250VAC, 16A	Figure 4-1
China	CAB-AC16A-CH=	14 feet (4.3 m)	250VAC, 16A	Figure 4-2
Continental Europe	CAB-AC-2500W-EU=	14 feet (4.3 m)	250VAC, 16A	Figure 4-3
International	CAB-AC-2500W-INT=	14 feet (4.3 m)	250VAC, 16A	Figure 4-4

Table 4-4 AC-Input Power Cord Options (continued)

Locale	Part Number	Length	Plug Rating	Power Cord Reference Illustration
Israel	CAB-AC-2500W-I SRL=	14 feet (4.3 m)	250VAC, 16A	Figure 4-5
Japan, North America (nonlocking plug) 200–240VAC operation	CAB-AC-2500W- US1=	14 feet (4.3 m)	250VAC, 16A	Figure 4-6
Japan, North America (locking plug) 200–240VAC operation	CAB-AC-C6K-T WLK=	14 feet (4.3 m)	250VAC, 16A	Figure 4-7
Japan, North America 100–120VAC operation1	CAB-7513AC=	14 feet (4.3 m)	125VAC, 20A	Figure 4-8
South Africa	CAB-7513ACSA=	14 feet (4.3 m)	250VAC, 16A	Figure 4-9
Switzerland	CAB-ACS-16=	8 feet 2 inches (2.5 m)	250VAC, 16A	Figure 4-10
Australia, New Zealand	CAB-AC-16A-AU S=	14 feet (4.3 m)	250VAC, 16A	Figure 4-11
Power Distribution Unit (PDU(=)*)	CAB-C19-CBN	9 feet (2.7 m)	250VAC, 16A	Figure 4-12

*The PDU power cable is designed for users who power their switch from a PDU. The end of the cable that plugs into the Cisco SCE8000 chassis has a C19 connector; the other end of the cable that plugs into the PDU has a C20 connector.

AC Power Cord Illustrations

This section contains the AC power cord illustrations.

Figure 4-1 AC Power Cord Plugs and Appliance Coupler for the 2700 W Power Supply

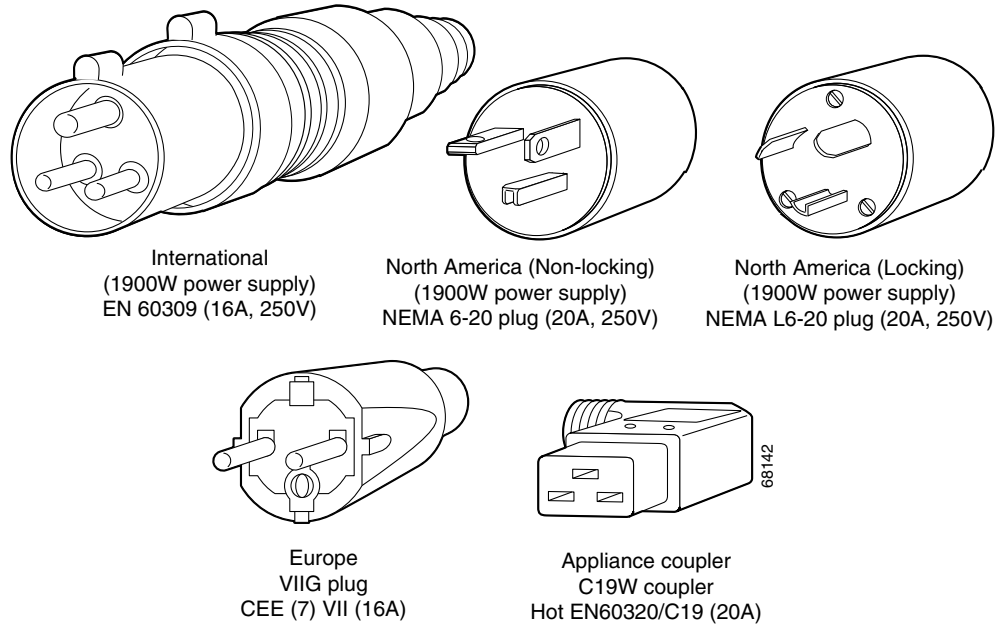
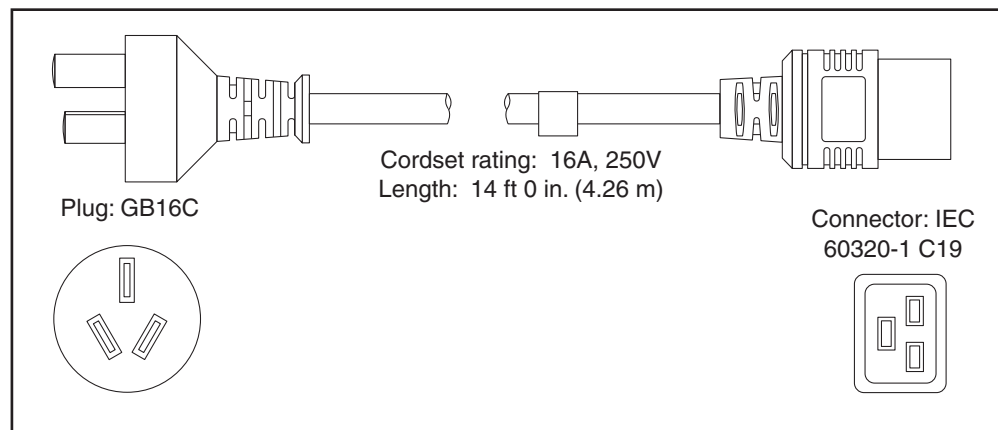


Figure 4-2 CAB-AC16A-CH=



126792

Figure 4-3 CAB-AC-2500W-EU=

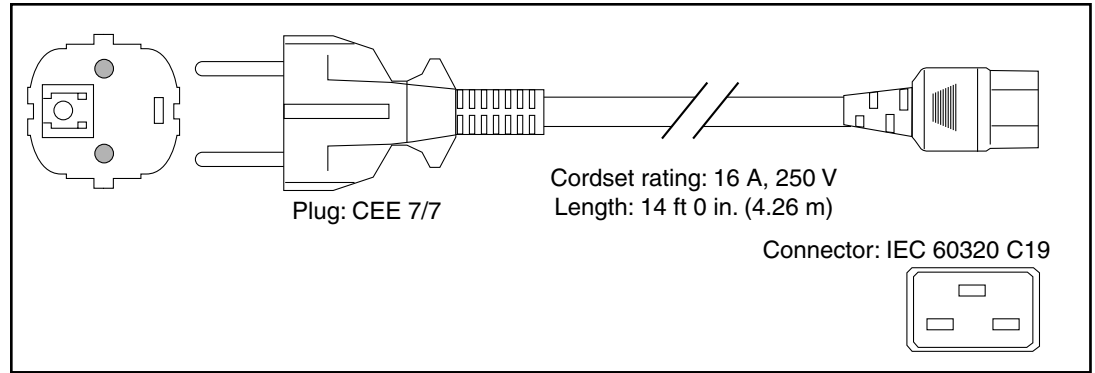


Figure 4-4 CAB-AC-2500W-INT=

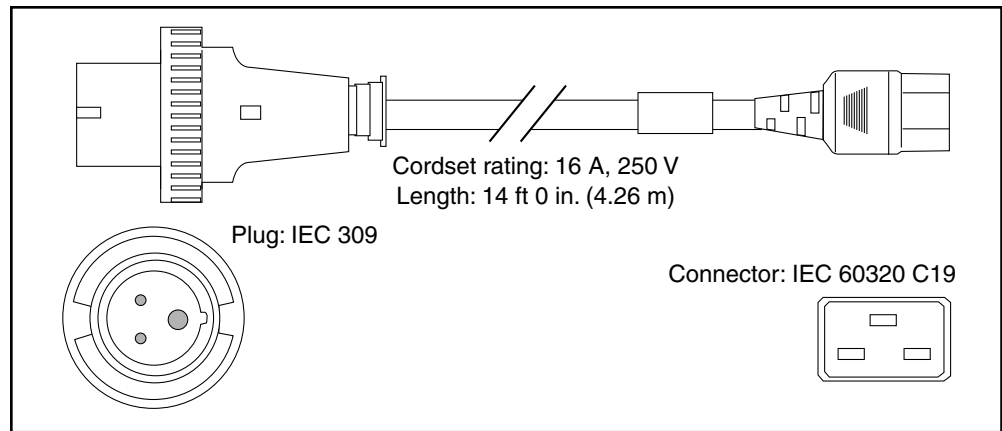


Figure 4-5 CAB-AC-2500W-ISRL=

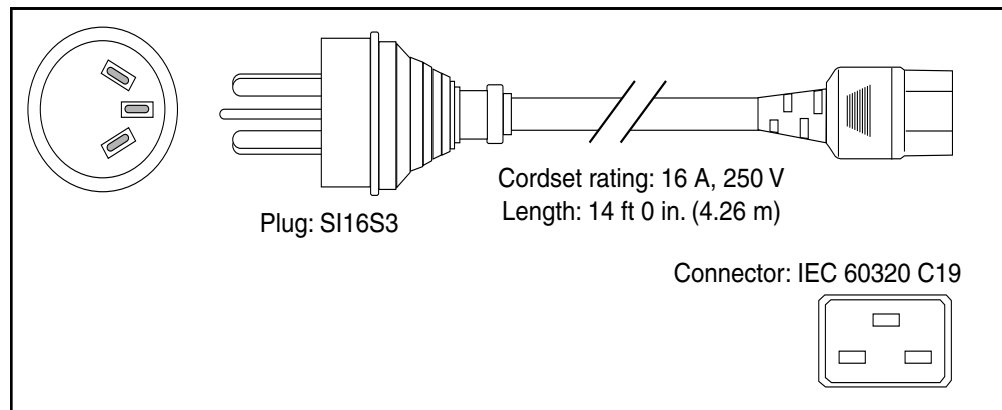


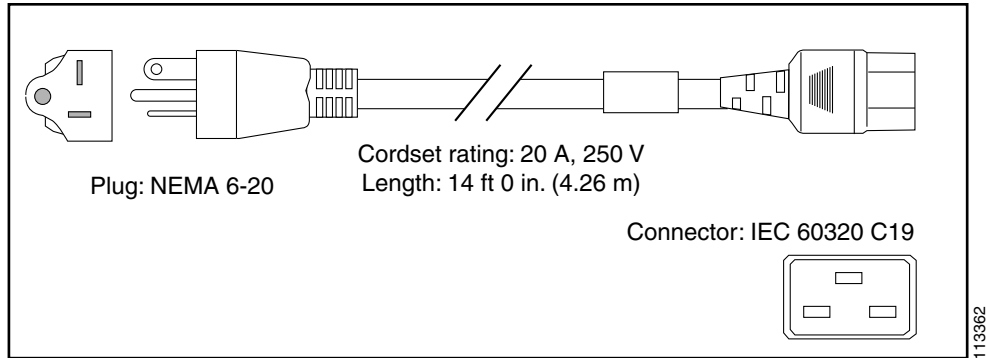
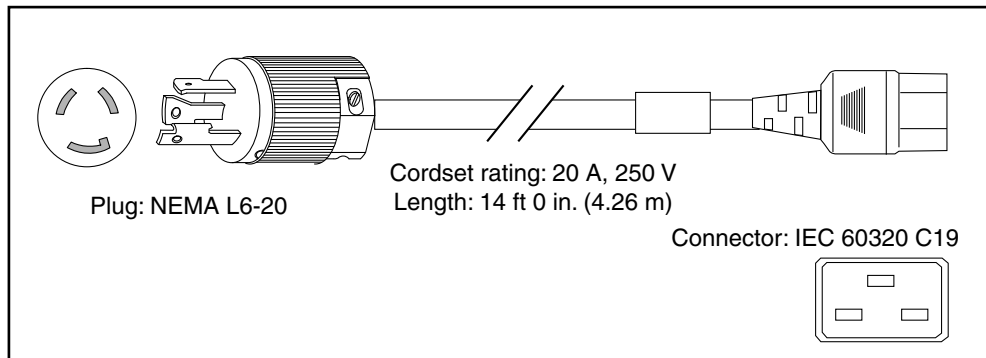
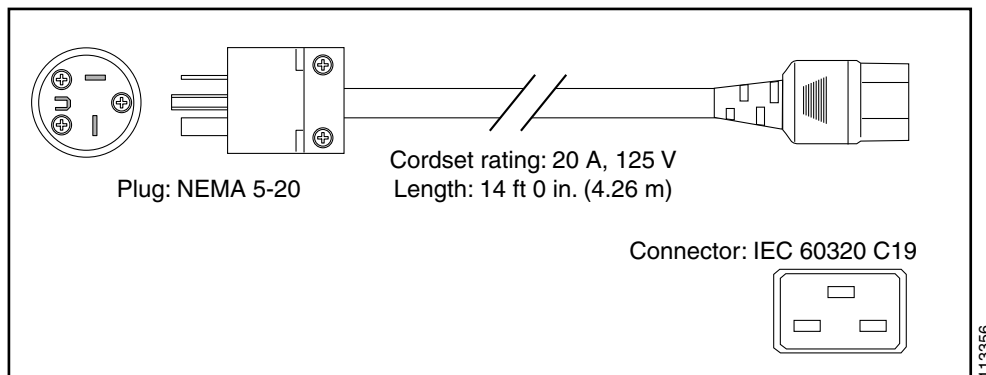
Figure 4-6 CAB-AC-2500W-US1=**Figure 4-7** CAB-AC-C6K-TWLK=**Figure 4-8** CAB-7513AC=

Figure 4-9 CAB-7513ACSA=

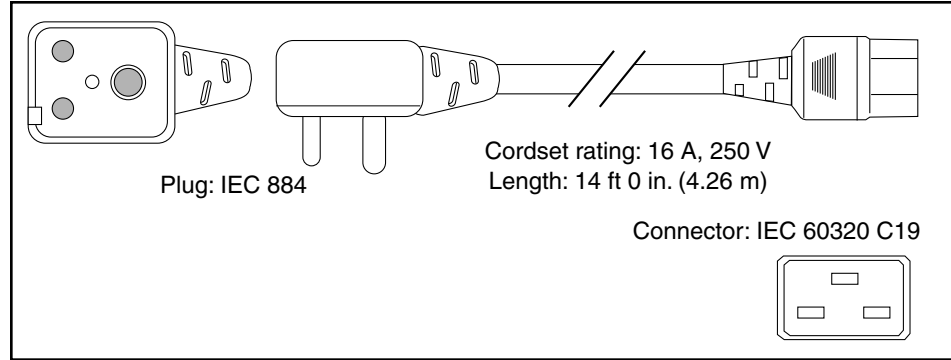


Figure 4-10 CAB-ACS-16=

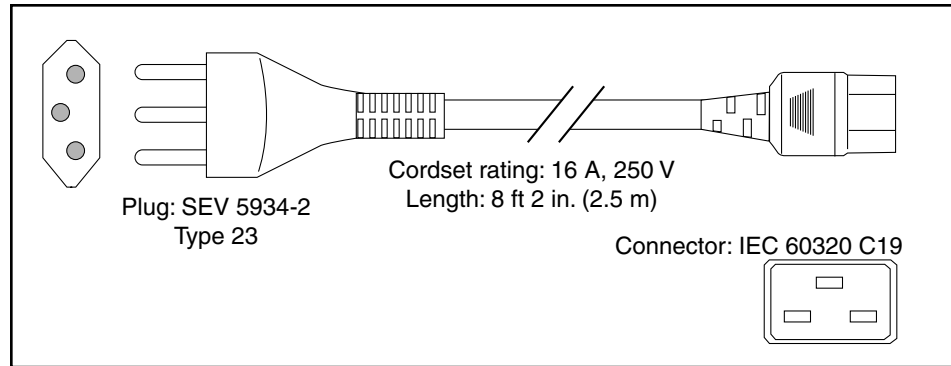


Figure 4-11 CAB-AC-16A-AUS

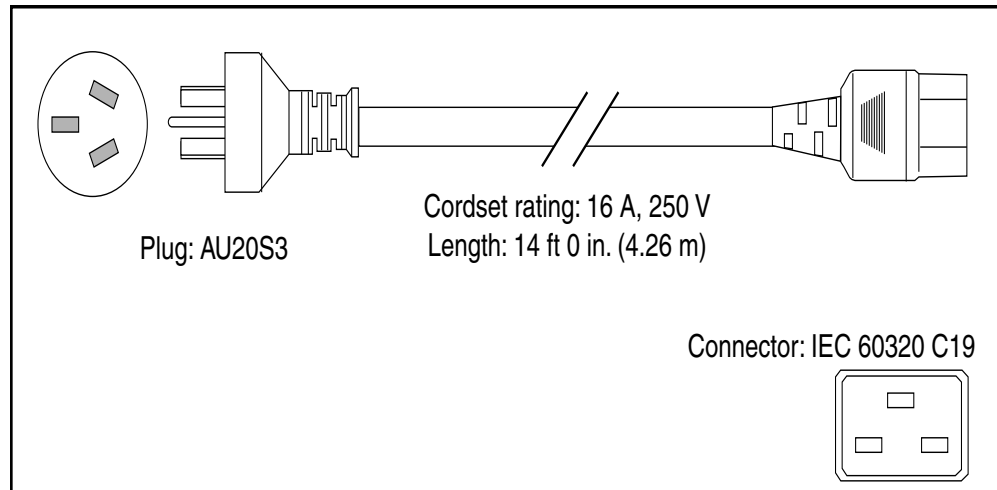
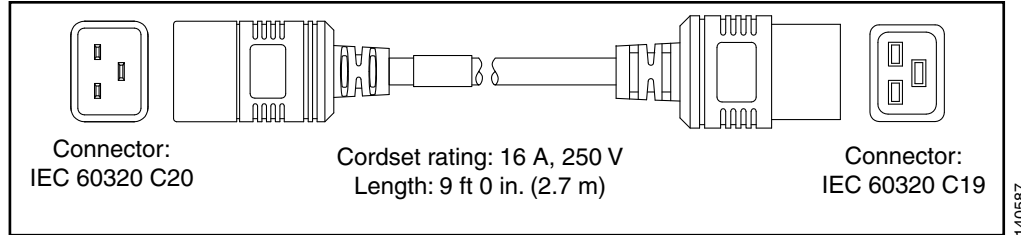


Figure 4-12 CAB-C19-CBN



DC-Powered Systems

Basic guidelines for DC-powered systems include the following:

- Each chassis power supply should have its own dedicated input power source. The source must comply with the safety extra-low voltage (SELV) requirements in the UL 60950, CSA 60950, EN 60950, and IEC 60950 standards.
- The DC supplies each have the provision for a dual connection to the power source in order to permit high-power operation without exceeding current ratings. For the SCE8000, it is not necessary to connect both of these inputs to DC power sources; it is sufficient to connect only the '1' connections.
- Each circuit must be protected by a dedicated two-pole circuit breaker. The circuit breaker should be sized according to the power supply input rating and local or national code requirements.
- The circuit breaker is considered the disconnect device and should be easily accessible.
- The system ground is the power supply and chassis ground.



Caution

Do not connect the DC-return wire to the system frame or to the system grounding equipment.

Table 4-5 lists the Cisco SCE 8000 DC power specifications.

Table 4-5 Cisco SCE 8000 DC Power Supply Specification

Specification	Acceptable Range
PWR-2700-DC/4 minimum capability	1350 W output (1750 W input)
DC-input power consumption	<ul style="list-style-type: none"> • Single SCE8000-SCM-E module: 1000 W (21 A @ 48 VDC, 17 A @ 60 VDC) • Dual SCE8000-SCM-E modules: 1430 W (30 A @ 48 VDC, 24 A @ 60 VDC)
DC-input voltage rating	-48 VDC to -40 VDC (operating range: -40.5 VDC to -72 VDC)
DC-input current rating	45 A maximum at 120 VAC

Table 4-5 Cisco SCE 8000 DC Power Supply Specification (continued)

Specification	Acceptable Range
DC-input cable	Accepts 2-14 AWG copper conductors. Actual size of the wire needed is determined by the installer or local electrician. Terminal block material rated at 150°C (302°F).
DC-input circuit breaker	For multiple DC input power supplies, each DC input must be protected by a dedicated two-pole circuit breaker or a fuse. The circuit breaker or the fuse must be sized according to the power supply input power rating and any local or national electrical code requirements.

**Note**

The DC supplies each have the provision for a dual connection to the power source in order to permit high-power operation without exceeding current ratings. For the Cisco SCE8000, it is not necessary to connect both of these inputs to DC power sources; it is sufficient to connect only the '1' connections.

Site Planning Checklist

Table 4-6 lists the site planning activities that you should perform before installing the Cisco SCE8000 chassis. Completing each activity helps ensure a successful installation.

Table 4-6 Site Planning Checklist

Task No.	Planning Activity	Verified By	Time	Date
1	Space evaluation: <ul style="list-style-type: none"> • Space and layout • Floor covering • Impact and vibration • Lighting • Maintenance access 			
2	Environmental evaluation: <ul style="list-style-type: none"> • Ambient temperature • Humidity • Altitude • Atmospheric contamination • Airflow 			
3	Power evaluation: <ul style="list-style-type: none"> • Input power type • Power receptacles • Receptacle proximity to the equipment • Dedicated (separate) circuits for redundant power supplies • UPS for power failures DC systems: Proper gauge wire and lugs			
4	Grounding evaluation: <ul style="list-style-type: none"> • Circuit breaker size • CO ground (AC- and DC-powered systems) 			
5	Cable and interface equipment evaluation: <ul style="list-style-type: none"> • Cable type • Connector type • Cable distance limitations 			
6	EMI evaluation: <ul style="list-style-type: none"> • Distance limitations for signaling • Site wiring • RFI levels 			

Installing the Cisco SCE8000 Chassis in the Rack

This section describes how to install a Cisco SCE8000 platform in a rack. For first-time installations, perform the procedures in the following sections in the order listed:

- [Unpacking the Cisco SCE8000 Chassis, page 4-15](#)
- [Installation Guidelines, page 4-16](#)
- [Required Tools, page 4-16](#)
- [Installing the Chassis Brackets, page 4-17](#)
- [Installing the Chassis in the Rack, page 4-17](#)
- [Installing an Optical Bypass Module, page 4-19](#)

**Note**

Before starting the installation procedures in this chapter, see the “[Site Planning Checklist](#)” section on page 4-12 to verify that all site planning activities were completed.

Unpacking the Cisco SCE8000 Chassis

**Tip**

Do not discard the shipping container when you unpack the Cisco SCE8000. Flatten the shipping cartons and store them with the pallet. You need these containers to move or ship the Cisco SCE8000.

Perform the following to check the contents of the shipping container:

- Check the contents of the accessories kit against the list of accessories in the “[Cisco SCE8000 Component and Accessory Lists](#)” section on page 2-13 and the packing slip. Verify that you received all listed equipment, which should include the following:
 - Hardware and software documentation, if ordered
 - Optional equipment that you ordered, such as network interface cables, transceivers, or special connectors
- Check the modules in each slot. Ensure that the configuration matches the packing list and that all the specified interfaces are included.

Installation Guidelines

Before installing the chassis, ensure that the equipment rack complies with the following guidelines:

- Width of the rack, measured between the two front mounting strips or rails, must be 17.75 in (45.09 cm).
- Depth of the rack, measured between the front and rear mounting strips, must be at least 19.25 in (48.9 cm) but not more than 32 in (81.3 cm).
- Rack must have sufficient vertical clearance to insert the chassis. The height of the Cisco SCE8000 chassis is 8.7 in (22.09 cm) (5 RU).

If the rack is on wheels, ensure that the brakes are engaged or that the rack is otherwise stabilized.

**Note**

We recommend that you maintain a minimum air space of 6 in (15 cm) between walls and the chassis air vents and a minimum horizontal separation of 12 in (30.5 cm) between two chassis to prevent overheating.

The installation hardware is not suitable for use with racks with obstructions (such as a power strip) that could impair access to field-replaceable units (FRUs).

**Note**

To prevent bodily injury when mounting or servicing this unit in a rack, you must take special precautions to ensure that the system remains stable. The following guidelines are provided to ensure your safety:

- This unit should be mounted at the bottom of the rack if it is the only unit in the rack.
 - When mounting this unit in a partially filled rack, load the rack from the bottom to the top with the heaviest component at the bottom of the rack.
 - If the rack is provided with stabilizing devices, install the stabilizers before mounting or servicing the unit in the rack.
-

Required Tools

These tools and equipment are required to install the chassis in the rack:

- Number 1 and number 2 Phillips-head screwdrivers
- 3/16-inch flat-blade screwdriver
- Tape measure and level
- Masking tape or some other method of marking the desired installation height in the rack

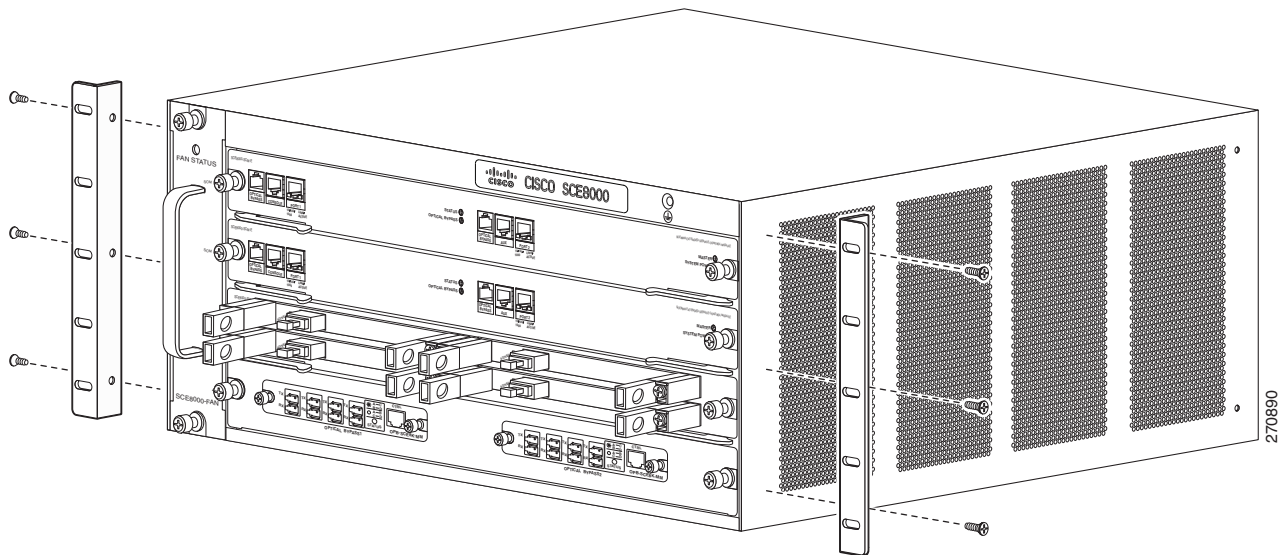
Installing the Chassis Brackets

The chassis is shipped with the mounting brackets installed on the front of the chassis. These brackets can be installed on the rear of the chassis.

To install the brackets on the rear of the chassis, perform these steps:

-
- Step 1** Remove the screws that secure the brackets to the chassis. (See [Figure 4-13](#).)

Figure 4-13 Brackets on Cisco SCE8000 Chassis



- Step 2** Position one of the brackets against the chassis side, and align the screw holes.
- Step 3** Secure the bracket to the chassis with the screws removed in Step 1.
- Step 4** Repeat [Step 2](#) and [Step 3](#) for the other bracket.
-

Installing the Chassis in the Rack



Caution

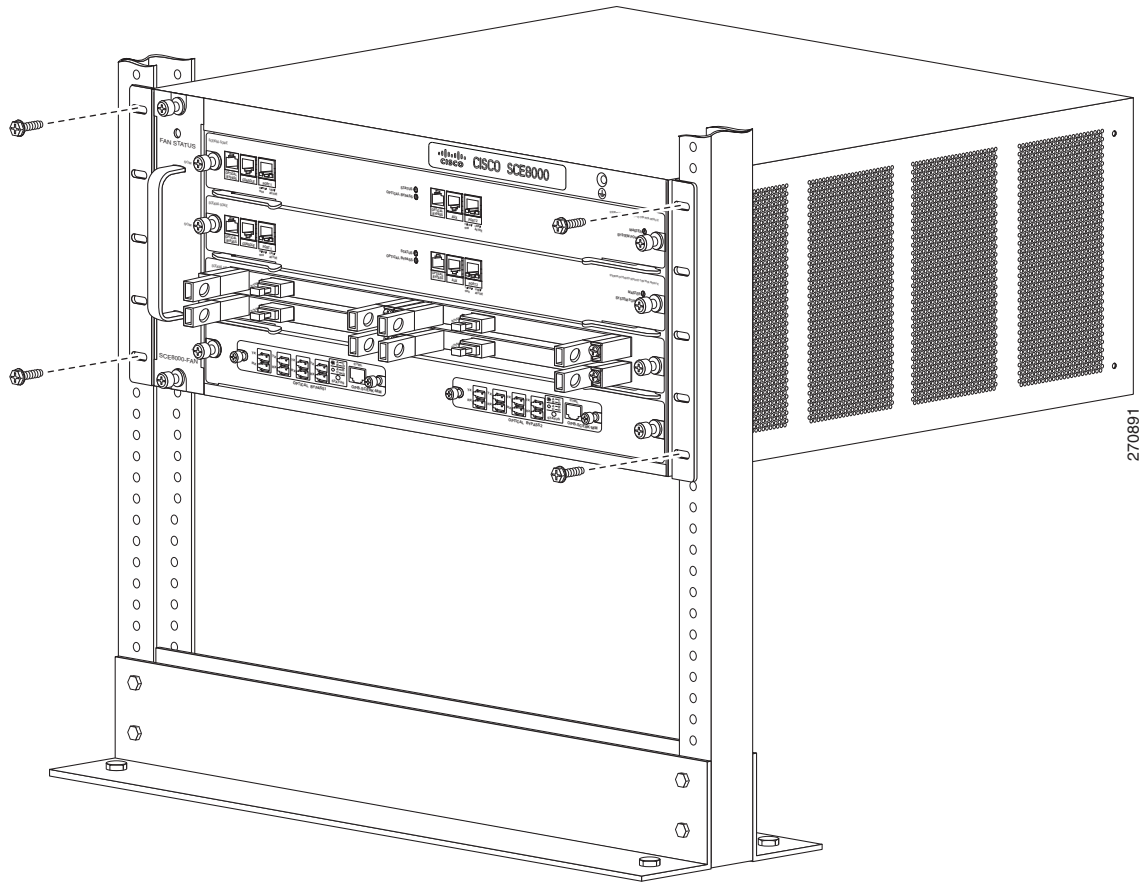
To prevent personal injury or damage to the chassis, never attempt to lift or tilt the chassis using the handles on modules (such as power supplies, fans, or cards); these types of handles are not designed to support the weight of the unit. Lift the unit only by grasping the chassis underneath its lower edge.

To install the Cisco SCE8000 chassis in the equipment rack, perform these steps:

-
- Step 1** Position the chassis in the rack as follows:
- If the front of the chassis (front panel) is at the front of the rack, insert the rear of the chassis between the mounting posts.
 - If the rear of the chassis is at the front of the rack, insert the front of the chassis between the mounting posts.

- Step 2** Align the mounting holes in the bracket (and optional cable guide) with the mounting holes in the equipment rack. (See [Figure 4-14](#).)
- Step 3** Use a tape measure and level to choose and mark the position that the chassis is to be installed in the rack. Make a mark at equal height on both sides of the rack. This helps ensure that the chassis is installed straight and level.

Figure 4-14 *Installing the Cisco SCE8000 Chassis in the Rack*



- Step 4** Install the eight (four per side) 12-24 x 3/4-inch or 10-32 x 3/4-inch screws through the holes in the bracket and into the threaded holes in the equipment rack posts.
- Step 5** Use a tape measure and level to verify that the chassis is installed straight and level.

Installing an Optical Bypass Module

There are two installation options for the external bypass modules:

- Chassis mount panel—This panel is mounted on slot 4 of the Cisco SCE8000 chassis. It hosts two optical bypass modules, which will serve the two traffic links supported by one Cisco SCE8000 chassis.
- External mounting panel—This panel can be mounted in any 19" rack. It hosts up to four optical bypass modules, which will serve the four traffic links supported by two Cisco SCE8000 platforms.

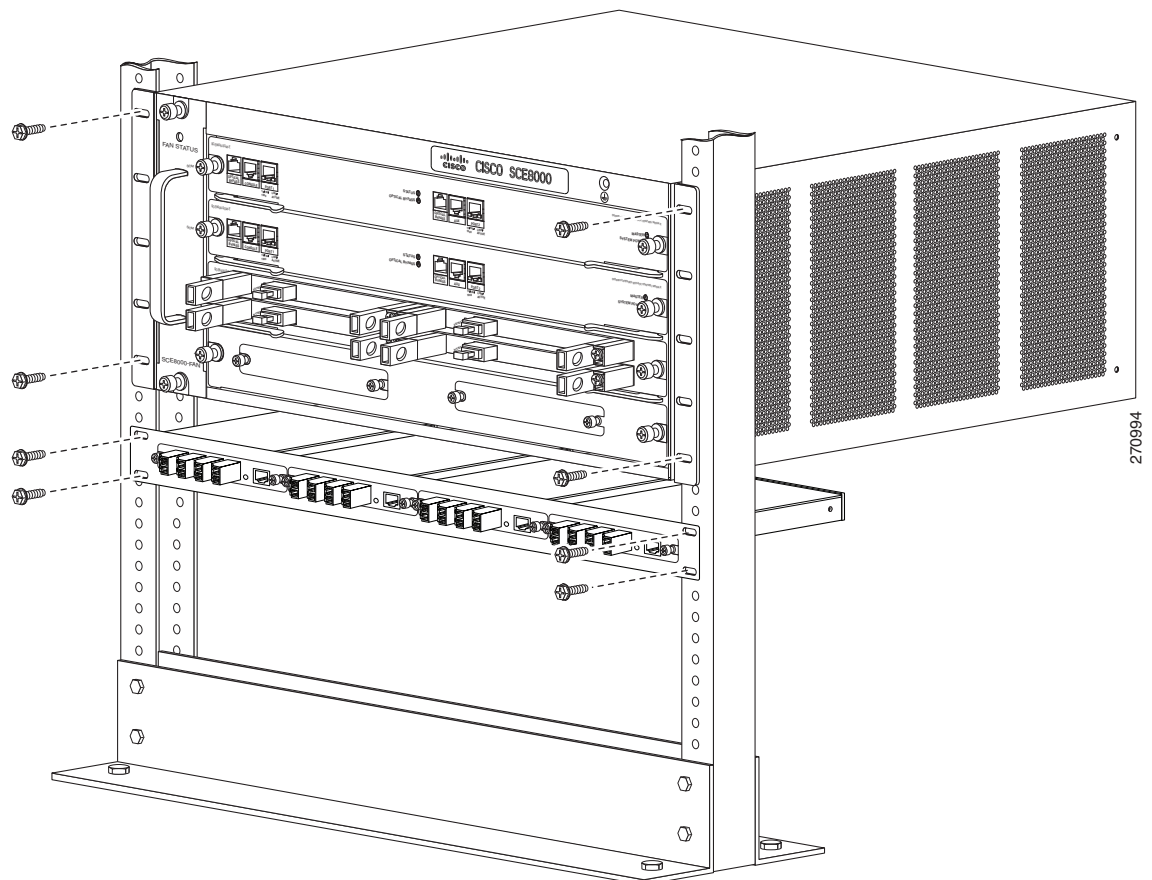
Step 1 For external mounting, install the external mounting panel in the 19" rack. Screw the mounting panel to the rack using four 3/4-inch screws, two on each side, through the holes in the mounting panel and into the threaded holes in the rack posts.

For internal mounting, the Cisco SCE8000 chassis is shipped with the chassis mounting panel already installed in slot 4.

Step 2 Remove the module filler plate covering the subslot in the mounting panel by loosening the two screws.

Step 3 Carefully insert the optical bypass module into the subslot (there are no guide rails) and tighten the captive screws on either side of the module. (See [Figure 4-15](#).)

Figure 4-15 Optical Bypass Modules in External Mounting Panel



270994

Connecting the System Ground

This section describes how to connect a system (earth) ground to the Cisco SCE8000 chassis.

Two threaded M4 holes are provided on the chassis frame to attach the ground cable.


Note

Connect the system ground on both AC- and DC-powered systems to an earth ground if this equipment is installed in a US or European Central Office.


Note

For DC-powered systems, the system ground is also the power supply ground. The DC ground must be installed with a permanent connection to an earth ground according to NEC guidelines.


Note

Complete this procedure before connecting system power or turning on the Cisco SCE8000 chassis.

Required Tools and Equipment

To connect the system ground, you need the following tools and materials:

- One grounding lug.
- Two M4 (metric) hex-head screws with locking washers.


Note

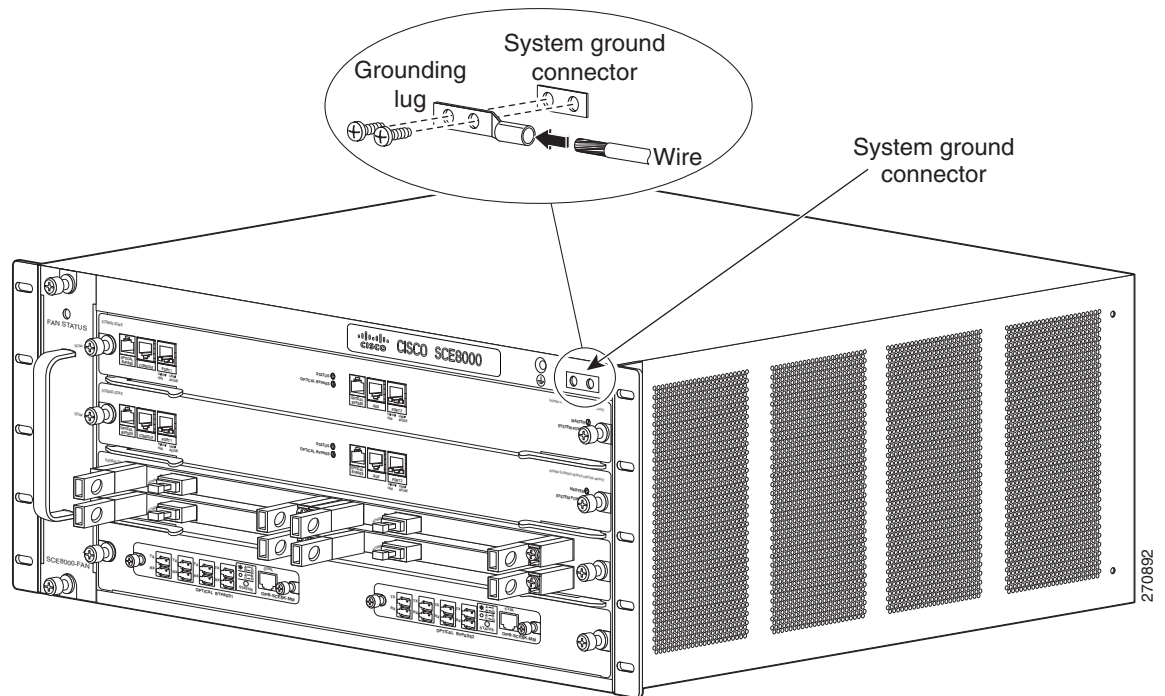
The grounding lug and M4 hex-head screws with locking washers are provided in kit 69-0815-01.

- One grounding wire.
The grounding wire must be sized according to local and national installation requirements. Depending on the power supply and system, a 12 AWG conductor or larger size wire is required for U.S. installations.
- Number 2 Phillips-head screwdriver.
- Crimping tool (must be large enough to accommodate the girth of the grounding lug when crimping the grounding cable into the lug).
- Wire-stripping tool.

-
- Step 1** Use a wire-stripping tool to remove approximately 0.75 inch (19 mm) of the covering from the end of the grounding wire.
- Step 2** Insert the stripped end of the grounding wire into the open end of the grounding lug.
- Step 3** Use the manufacturer recommended crimping tool to secure the grounding wire in place in the grounding lug.

- Step 4** Locate and remove the adhesive label from the system grounding pad on the chassis. (See [Figure 4-16](#).)

Figure 4-16 *Installing the System Ground*



- Step 5** Place the grounding wire lug against the grounding pad, making sure there is solid metal-to-metal contact.
- Step 6** Secure the grounding lug to the chassis with two M4 screws. Ensure that the grounding lug will not interfere with other hardware or rack equipment.
- Step 7** Prepare the other end of the grounding wire, and connect it to an appropriate grounding point in your site to ensure adequate earth ground for the Cisco SCE8000 chassis.

Installing the Power Supplies in the Cisco SCE8000 Chassis

The Cisco SCE8000 chassis is shipped with the power supplies (AC or DC) already installed. Should it be necessary to install a power supply module, see the [“Removing and Replacing the Power Supply”](#) section on page 9-3.