



# Remote PHY DVB Video on Demand

The Digital Video Broadcasting (DVB) protocol for encrypting video services as defined in the ETSI TS 103 197 DVB Simulcrypt specification has been implemented on the line card for DVB R-PHY on Cisco cBR-8. This document contains an overview of the commands for configuring DVB and the commands for viewing the status of the encryption of services.

Your software release may not support all the features that are documented in this module. For the latest feature information and caveats, see the release notes for your platform and software release. The Feature Information Table at the end of this document provides information about the documented features and lists the releases in which each feature is supported.

- [Information About DVB VOD, on page 1](#)
- [How to Configure DVB, on page 3](#)
- [Configuration Examples, on page 7](#)
- [Additional References, on page 10](#)
- [Feature Information for RPHY DVB VoD Support, on page 10](#)

## Information About DVB VOD

### Overview of DVB VOD

This feature enables the operator to scramble the video sessions on the chassis. It involves the configuration to establish a connection with the Entitlement Control Message Generator (ECMG) and the Event Information Scheduler (EIS).

The two primary modes of scrambling are: session based scrambling and tier-based scrambling. The basic difference between the two modes is that the manner in which the Entitlement Control Messages (ECM) are requested from the ECMG. For session based scrambling, a control word (CW) is generated once every Crypto Period (CP) and the ECM is requested for each session. For tier-based scrambling, the control word is generated once every CP and the ECM generated by the ECMG for the CW is used by all the sessions in the chassis.

### Session based Scrambling Setup

The connection with the external EIS Server is established via the Virtual Port Group in the Supervisor. The connection with the external ECMG server is established via the linecard.

Figure 1: Session based Setup

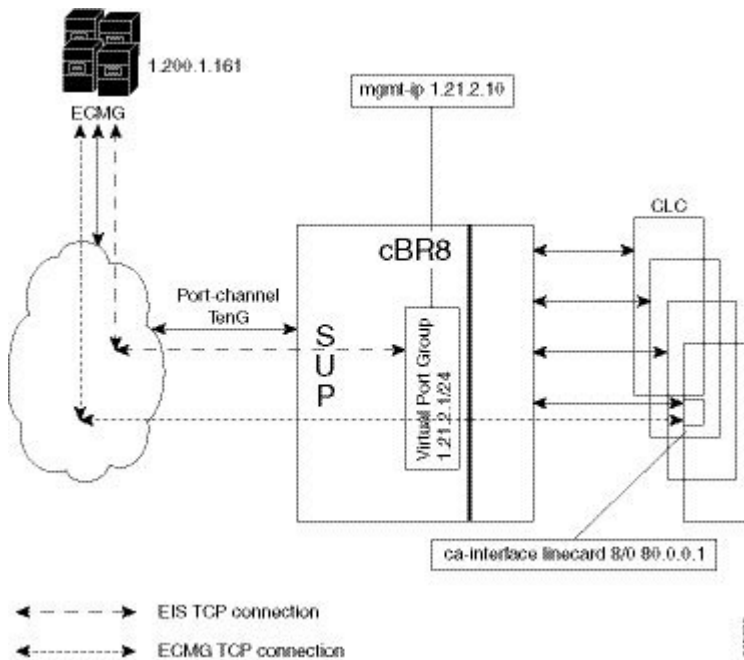

## Fail-to-Clear

The fail-to-clear-duration feature is supported on DVB sessions and DualCrypt encryption modes. Based on the session encryption, the following two features are supported on the Cisco cBR Series Converged Broadband Routers.

### Fail-to-Clear Duration for DVB Session-based Encryption

This feature is used along with DVB or DualCrypt encryption with external Event Information Scheduler (EIS) configuration. When encryption for a session fails in the Cisco cBR-8, this feature enables the operator to control the configured DVB-encrypted sessions to function without encryption for a configured duration. If the encryption still fails, the DVB session is marked as `Fail-to-black` after the fail-to-clear duration timeout.

### Fail-to-Clear for DVB Tier-based Encryption

This feature is used along with Tier-based configuration. When encryption for a session fails in Cisco cBR-8, this feature enables the operator to control the configured DVB-encrypted sessions to function without encryption.

If fail-to-clear is configured, tier-based configuration is enabled, and then if the encryption fails, the DVB session's `Encrypt Status` is marked as `clear`. The status changes to `Encrypted` when the encryption starts.

This feature is not enabled by default.

## Tier based Scrambling Setup

The connection with the external ECMG server is established via the Virtual Port Group in the Supervisor.

Figure 2: Tier based Setup

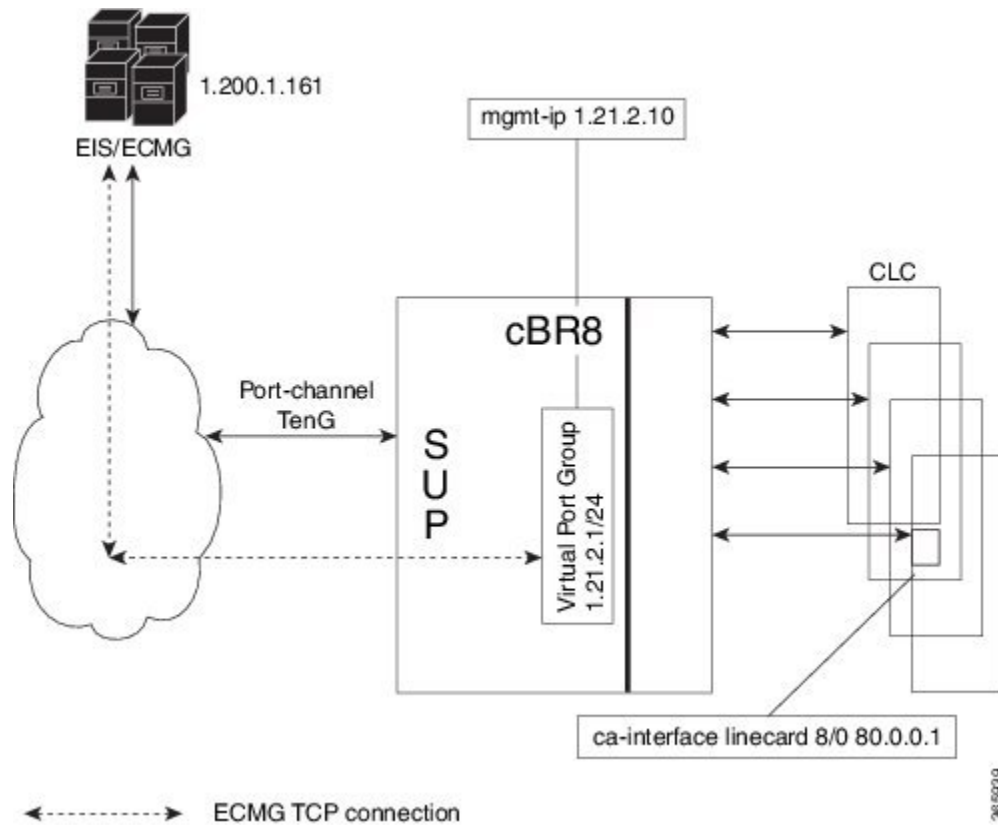

## Restrictions for DVB

- This feature is applicable only for remapped table based sessions.
- Fail-to-clear-duration feature is applicable only to session-based scrambling for DVB CAS encryption.
- Fail-to-clear feature is applicable only to DVB tier-based scrambling sessions.

## How to Configure DVB

### Configuring RPHY DVB VoD

#### Before You Begin

- Virtual Port Group interface must be configured and the management IP for DVB must be identified.
- Management interface is set to this Virtual Port Group interface under cable video configuration.
- Logical Edge Device is configured with the table based protocol.
- The encryption algorithm of the linecard is set to DVB-CSA.

- For session based scrambling, the CA interface on the linecard and the route for reaching the ECMG server must be specified.

To configure session based scrambling, follow the steps below:

```
enable
config terminal
interface int_id
  vrf forwarding vrf_script_red_1
  ip address ip-address subnet-mask
  no mop enabled
  no mop sysid
  exit
cable video
  mgmt-intf VirtualPortGroup group_id
  encryption
    linecard slot/bay ca-system dvb scrambler dvb-csa
    dvb
      route-ecmg ECMG_Server_IP_Address Netmask Interface Forwarding_Router_IP_Address
      mgmt-ip management ip address
      eis EIS_name id EIS_id
        listening-port <1-65535> bind led id <led id | led name>
      ca-interface linecard slot/bay IP_Address
      ecmg ECMG_Name id ECMG_ID
        mode vod linecard slot/bay
        type standard
        ca-system-id CA_System_ID CA_Subsystem_ID
        auto-channel-id
        ecm-pid-source sid
        connection id ID priority connection_priority IP_Address Port
      service-distribution-group sdg name id SDG ID onid onid number
      rpd downstream-cable slot/subslot/bay
      virtual-carrier-group vcg-name id vcg_id
      encrypt
      service-type narrowcast
      rf-channel channel tsid tsid_number output-port-number number
  bind-vcg
    vcg vcg-name sdg sdg-name
  logical-edge-device led-name id led_id
  protocol gqi
    mgmt-ip IP_Address
    mac-address MAC address
    server server_ip_address
    keepalive retry 3 interval 10
    reset interval 8
    virtual-edge-input-ip IP address input-port-number 1
  vcg vcg-name
  active
```

The fail-to-clear-duration is measured in seconds. The valid values are in the range from 0 to 10800 seconds. The default value is 0.

To configure tier based scrambling, follow the steps below:

```
enable
config terminal
interface VirtualPortGroup group_id
  vrf forwarding Mgmt-intf
  ip address ip-address subnet-mask
  no mop enabled
  no mop sysid
  exit
```

```

cable video
  mgmt-intf VirtualPortGroup group_id
  encryption
    linecard slot/bay ca-system dvb scrambler dvb-csa
    dvb
      route-ecmg ECMG_Server_IP_Address Netmask Interface Forwarding_Router_IP_Address
      ecmg ECMG_Name id ECMG_ID
        mode tier-based
        type standard
        ca-system-id CA_System_ID CA_Subsystem_ID
        auto-channel-id
        ecm-pid-source sid
        connection id ID priority connection_priority IP_Address Port
      tier-based
        ecmg id ECMG_ID access- criteria access_criteria_in_hex
        fail-to-clear
        enable
      service-distribution-group sdg name id SDG ID onid onid number
        rpd downstream-cable slot/subslot/port
      virtual-carrier-group vcg-name id vcg_id
        encrypt
        service-type narrowcast
        rf-channel channel tsid tsid_number output-port-number number
      bind-vcg
        vcg vcg-name sdg sdg-name
      logical-edge-device led-name id led_id
        protocol table-based
        virtual-edge-input-ip IP address input-port-number 1
        vcg vcg-name
        active
      table-based
        vcg vcg-name
        rf-channel channel
        session session_name input-port id start-udp-port udp port number processing-type
      remap start-program 1 cbr

```



---

**Note** If the tier-based configuration is already enabled, you must first disable the tier-based configuration using the **no enable**, before you configure fail-to-clear feature.

---

## Verifying the DVB Configuration

To verify the configuration of the encryption algorithm on the linecard, use the **show cable video encryption linecard** command as shown in the example below:

```

Router# show cable video encryption linecard 7/0
Line card: 7/0
CA System      Scrambler      DVB-Conformance
=====
dvb            dvb-csa        Enabled

```

To verify the ECMG connection, use the **show cable video encryption dvb ecmg id id connection** command as shown in the example below:

```

Router# show cable video encryption dvb ecmg id 1 connection
-----
ECMG ECMG          ECMG      CA Sys CA Subsys PID      Lower Upper Streams/ Open Streams/

```

```

Auto Chan Slot ECMG      ECMG
ID  Name      Type      ID      ID      Source limit limit ECMG      ECMG      ID
Connections Application
-----
1   polaris_ecmg01 standard 0x4748 0x0      sid    0    0    1    1
Enabled RP 1      Tier-Based

```

ECMG Connections for ECMG ID = 1

```

-----
Conn Conn      IP      Port      Channel  Conn      Open
-ID  Priority Address  Number  ID        Status  Streams
-----
1    1          10.10.1.1 8888     1        Open     1

```

The sample output of the session based scrambling configuration verification command is shown below:

Router# **show cable video encryption dvb ecmg id 7 connection**

```

ECMG ECMG      ECMG      CA Sys CA Subsys PID      Lower Upper Streams/ Open Streams/
Auto Chan Slot ECMG      ECMG
ID  Name      Type      ID      ID      Source limit limit ECMG      ECMG      ID
Connections Application
-----
7   ecmg-7      standard 0x950 0x1234  sid    0    0    1680 1680
Enabled 7 1      VOD

```

ECMG Connections for ECMG ID = 1

```

-----
Conn Conn      IP      Port      Channel  Conn      Open
-ID  Priority Address  Number  ID        Status  Streams
-----
1    1          10.10.1.10 8888     1        Open     1

```

The status of the connection with the ECMG Server is indicated by the Conn Status. The Open Streams field indicates the number of Active ECM Streams.

To verify the EIS connection, use the **show cable video encryption dvb eis id id** command as shown in the example below:

Router# **show cable video encryption dvb eis id 1**

```

-----
EIS EIS Peer      Management TCP CP      CP      Overwrite Fail-To-Clear Connection
ID  Name IP      IP      Port Overrule Duration SCG      Duration  Status
-----
1   test 10.10.1.11 10.10.1.1 9898 DISABLED 0      DISABLED 400      Connected

```

To verify the CA Interface configuration in the case of session based scrambling, use the **show cable video encryption dvb ca-interface brief** command as shown in the example below:

Router# **show cable video encryption dvb ca-interface brief**

CA Interface configuration

```

-----
Linecard      IP Address      VRF
-----
7             10.10.1.1      N/A

```

ECMG Route configuration

```

-----
IP Address      NetMast      Interface
-----

```

```
10.10.1.10      255.255.255.224      TenGigabitEthernet4/1/2
```

To verify the encryption status of the sessions, use the **show cable video session logical-edge-device id** command as shown in the example below:

```
Router# show cable video session logical-edge-device id 1
```

```
Total Sessions = 1
```

Session Id	Output State	Input Port	Streaming Output Type	Session Output Type	Session Encrypt Type	Session Encrypt Status	Source Low Ucast Dest IP/Mcast Latency Name	UDP IP (S, G) Port	Output Program	Input State
1048576	1		Remap	UDP	10.10.1.1			49167 20		ACTIVE-PSI
	1695161	1689747	DVB	Encrypted	N		dvbssess.1.0.1.0.23167			

To verify the ECM PID and whether the CA Descriptor is added to the PMT, use the **show cable video session logical-edge-device id session-id** command as shown in the example below:

```
Router# show cable video session logical-edge-device id 1 session-id 1048576
```

```
Output PMT Info:
```

```
=====
```

```
Program 20, Version 3, PCR 49, Info len 18, (CA SYS-ID 4748, PID 79)
```

```
PID 49: Type 2, Info len 0
```

```
PID 50: Type 3, Info len 6, (lang eng)
```

## Troubleshooting Tips

If some configuration errors occur, see the following troubleshooting tips:

- The Management IP must be unique and in the subnet of virtual port group.
- Ensure that the ECMG Server is pingable with source interface as the virtual port group from the Cisco cBR-8 console. This indicates that the ECMG Server is reachable and route is valid.
- Ensure that the TCP port number configured for the ECMG Server in the Cisco cBR-8 is the same as that of the ECMG Server listening port.
- Ensure that the management IP is pingable from the EIS Server. Otherwise, check the routing between the cBR-8 chassis and the EIS server.
- Ensure that the listening port that is configured for the EIS is used for establishing the connection from the EIS Server.
- Ensure that the Virtual Port Group interface is active.
- Ensure that the TenGigabitEthernet interface using which the management traffic reaches the Cisco cBR-8 and the interface through which the CA interface route is configured are active.

## Configuration Examples

This section provides examples for the DVB configuration.

## Example: Basic Session-based Scrambling Configuration

```

enable
config terminal
interface VirtualPortGroup0
  vrf forwarding vrf_script_red_1
  ip address 10.10.1.1 255.255.255.224
  no mop enabled
  no mop sysid
  exit
cable video
  mgmt-intf VirtualPortGroup 0
  encryption
    linecard 7/0 ca-system dvb scrambler dvb-csa
    dvb
      route-ecmg 10.20.1.1 255.255.255.224 TenGigabitEthernet4/1/2 10.20.1.1
      mgmt-ip 10.10.1.2
      eis eis-1 id 1
        listening-port 8890 bind led id 1
      ca-interface linecard 7/0 10.30.1.1
      ecmg ecmg-7 id 7
        mode vod linecard 7/0
        type standard
        ca-system-id 950 1234
        auto-channel-id
        ecm-pid-source sid
        connection id 1 priority 1 10.20.1.3 8888
      service-distribution-group sdg-1 id 1 onid 1
        rpd downstream-cable 7/0/1
      virtual-carrier-group vcg-1 id 1
        encrypt
        service-type narrowcast
        rf-channel 0 tsid 1 output-port-number 1
      bind-vcg
        vcg vcg-1 sdg sdg-1
      logical-edge-device led-1 id 1
        protocol table-based
        virtual-edge-input-ip 192.0.2.0 input-port-number 1
        vcg vcg-1
        active
      table-based
        vcg vcg-1
      rf-channel 0
      session dvb-1 input-port 1 start-udp-port 49152 processing-type
      remap start-program 1 cbr

```

## Example: Basic Tier-based Scrambling Configuration

```

enable
config terminal
interface VirtualPortGroup0
  vrf forwarding vrf_script_red_1
  ip address 10.10.1.1 255.255.255.224
  no mop enabled
  no mop sysid
  exit
cable video
  mgmt-intf VirtualPortGroup 0
  encryption
    linecard 7/0 ca-system dvb scrambler dvb-csa

```

```

dvb
  route-ecmg 10.20.1.0 255.255.255.224 TenGigabitEthernet4/1/2 10.20.1.1
  ecmg ecmg-7 id 7
    mode tier-based
    type standard
    ca-system-id 950 1234
    auto-channel-id
    ecm-pid-source sid
    connection id 1 priority 1 10.20.1.3 8888
  tier-based
    ecmg id 7 access-criteria 1122334455
    fail-to-clear
    enable
  service-distribution-group sdg-1 id 1 onid 1
    rpd downstream-cable 7/0/1
  virtual-carrier-group vcg-1 id 1
    encrypt
    service-type narrowcast
    rf-channel 0 tsid 1 output-port-number 1
  bind-vcg
    vcg vcg-1 sdg sdg-1
  logical-edge-device led-1 id 1
    protocol table-based
    virtual-edge-input-ip 192.0.2.0 input-port-number 1
    vcg vcg-1
    active
  table-based
    vcg vcg-1
    rf-channel 0
    session dvb-1 input-port 1 start-udp-port 49152 processing-type remap start-program
1 cbr

```

## Example: Basic Session-based Dualcrypt Scrambling Configuration

```

enable
config terminal
  interface VirtualPortGroup0
    vrf forwarding vrf_script_red_1
    ip address 10.10.1.1 255.255.255.224
    no mop enabled
    no mop sysid
  exit
cable video
  mgmt-intf VirtualPortGroup 0
  encryption
    linecard 7/0 ca-system dvb scrambler dvb-csa
  dvb
    route-ecmg 10.20.1.0 255.255.255.224 TenGigabitEthernet4/1/2 10.20.1.1
    mgmt-ip 10.10.1.2
    eis eis-1 id 1
      listening-port 8890 bind led id 1
    ca-interface linecard 7/0 10.30.1.1
    ecmg ecmg-7 id 7
      mode vod linecard 7/0
      type standard
      ca-system-id 950 1234
      auto-channel-id
      ecm-pid-source sid
      connection id 1 priority 1 10.20.1.3 8888
    service-distribution-group sdg-1 id 1 onid 1
      rpd downstream-cable 7/0/1
  virtual-carrier-group vcg-1 id 1
    encrypt

```

```

service-type narrowcast
rf-channel 0 tsid 1 output-port-number 1
bind-vcg
vcg vcg-1 sdg sdg-1
logical-edge-device led-1 id 1
protocol gqi
  mgmt-ip 10.10.1.3
  mac-address xxxx.yyyy.zzzz
  server 10.20.1.2
  keepalive retry 3 interval 10
  reset interval 8
  virtual-edge-input-ip 192.0.2.0 input-port-number 1
vcg vcg-1
active

```

## Additional References

### Related Documents

Related Topic	Document Title
Configuring Tier-Based Scrambling	<i>Cisco RF Gateway 10 Software Configuration Guide</i>

### Technical Assistance

Description	Link
<p>The Cisco Support website provides extensive online resources, including documentation and tools for troubleshooting and resolving technical issues with Cisco products and technologies.</p> <p>To receive security and technical information about your products, you can subscribe to various services, such as the Product Alert Tool (accessed from Field Notices), the Cisco Technical Services Newsletter, and Really Simple Syndication (RSS) Feeds.</p> <p>Access to most tools on the Cisco Support website requires a Cisco.com user ID and password.</p>	<a href="http://www.cisco.com/support">http://www.cisco.com/support</a>

## Feature Information for RPHY DVB VoD Support



**Note** The following table lists the software release in which a given feature is introduced. Unless noted otherwise, subsequent releases of that software release train also support that feature.

*Table 1: Feature Information for RPHY DVB VoD Support*

Feature Name	Releases	Feature Information
RPHY DVB VoD Support	Cisco 1x2 / Compact Shelf RPD Software 3.1	This feature was introduced on the Cisco Remote PHY Device.