



Video QAM Replication

The Video QAM replication feature allows video carriers to be replicated to support service group alignment between DOCSIS and Video service groups.

Contents

- [QAM Replication, on page 1](#)
- [Information About Replication, on page 1](#)
- [Configuring Replication for Table-Based or Session-Based Video, on page 3](#)
- [Configuration Examples, on page 4](#)
- [Feature Information for Replication, on page 5](#)

QAM Replication

The QAM replication feature allows duplication of content on multiple QAM carriers. This feature is internal to the cBR-8 and replaces the need for external splitters, allowing content to be replicated across multiple ports on a line card.

Information About Replication

- **Multiple Ports:** Multiple ports in a Service Distribution Group (SDG) replicate all QAMs from the Virtual Carrier Group (VCG) to output port listed in the same SDG.
- **Unicast:** Unicast (Video on Demand) services cannot be replicated across line cards.

Overview of QAM Replication

Video on Demand (VoD) or unicast services cannot be replicated across line cards. You can accomplish replication by adding more than one RF port to an SDG. This feature works for the SDG regardless of whether the video sessions are table-based or session-based.

Replication also applies to the QAM PHY parameters. Hence, the QAM PHY parameters like frequency, annex, and symbol rate of the replicated QAM carrier are the same as the QAM PHY parameters on the pilot QAM carrier.

QAM replication is achieved in two ways: software and hardware. The line card performs the hardware QAM replication. Each line card has the capability to replicate an output QAM (Pilot QAM) from one port to another output QAM (Replicate QAM) on another port.



Note QAM replication in the same port is not supported.

The **service-distribution-group** construct is used to perform replication. Hardware replication is supported when the replication of individual QAM Carriers is limited to the same line card.

The **bind-vcg** construct, which is used to determine the physical QAMs to be replicated, is analogous to combiner and splitter combination. The RF ports combine all the QAMs routed to them. Then, one or more inputs are split to one or more RF output ports.

Benefits of QAM Replication

QAM replication reduces the need for external HFC components like splitters and combiners in the RF plant.

The figure below illustrates the bind operation that replaces a combiner and a splitter and performs replication on multiple ports that are assigned to an SDG.

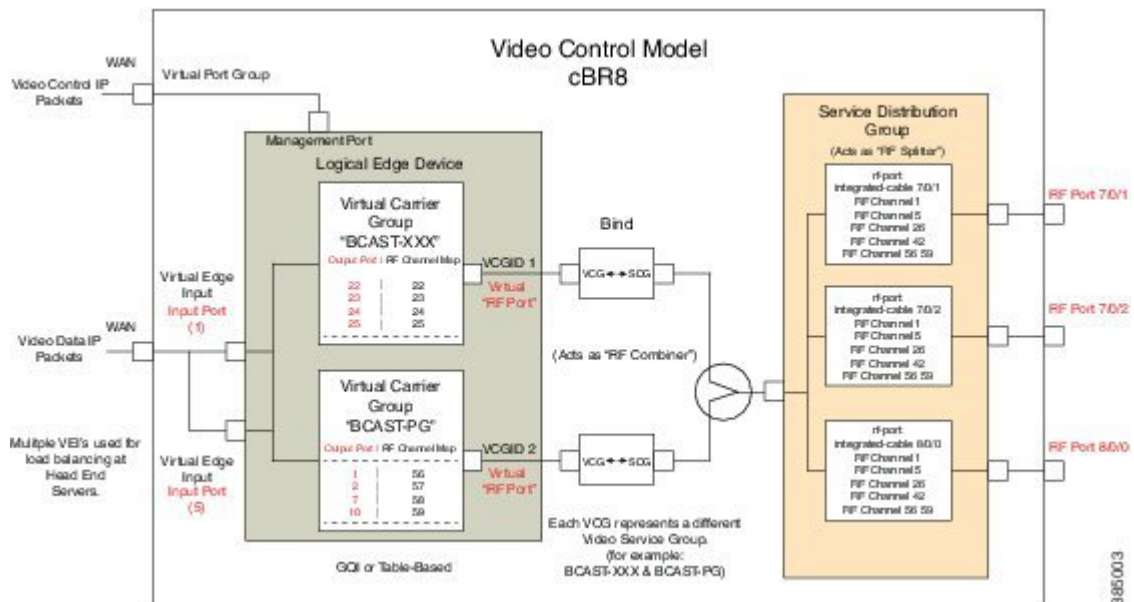

Prerequisites for Replication

The controller type for the slot/bay/port used for the SDG should be set as 'VIDEO'. The errors corresponding to the incorrect controller type used in the SDG appear during the bind operation.

Perform the following steps to set the controller type:

```
configure terminal
controller Integrated-Cable slot/bay/port
rf-channel start-channel - end-channel
type VIDEO
```

```

start-frequency frequency
rf-output normal
power-adjust number
qam-profile qam-profile number

```

Restrictions for QAM Replication

- Hardware can support QAM replication only within the same line card.
- The output of a source QAM in any port can be replicated to only one QAM in another port. Replication within the same port is not supported.
- The current line card has a maximum of eight ports. Hence, for each line card a pilot QAM can have up to seven replicates (one on each port).
- Standard routing protocols prohibit routing of unicast traffic (VOD) to multiple destinations (across line cards).

Configuring Replication for Table-Based or Session-Based Video

Replication is configured within the SDG by adding a set of RF ports to the same SDG. To configure replication you must choose the Pilot QAM carriers, a set of QAM carriers belonging to a RF port. The Pilot QAM carriers are denoted by the first RF port added under SDG. The rest of RF ports, which carry the replicated content, are specified within this SDG.

Choose the QAM carriers, which carry the content to be replicated, by configuring Virtual Carrier Group (VCG) and specifying the number of QAM channels that are replicated in each RF port. When the pilot QAM carrier is removed, one of the remaining replicated QAM carriers is automatically chosen as pilot QAM carrier.

To configure the replication, complete the following procedure:

```

configure terminal
cable video
service-distribution-group service distribution group name
rf-port integrated-cable slot/bay/port
rf-port integrated-cable slot/bay/port
virtual-carrier-group vcg_replication id number
virtual-edge-input-ip ip-address vrf vrf-name input-port-number number
rf-channel n-m tsid n-m output-port-number n-m
bind-vcg
vcg vcg_replication sdg sdg_replication

```

Verifying Replication of Table Based Video Sessions

To verify the replication information including the replication group ID, pilot or replicant, and the associated status, use the **show cable card slot/bayqam-repl group** command as shown in the example below:

```
Router#show cable card 7/0 qam-repl group
```

```

-----
Grp Slot Chan QAM Grp   Chan
ID Grp cnt type State List
ID [port:chan state role]

```

```
U:Up    P:Pilot
D:Down  R:Replicant
```

```
-----
57344 0   4  VID  U   0:21  UP   1:21  UR   2:21  UR   3:21  UR
57345 1   4  VID  U   0:22  UP   1:22  UR   2:22  UR   3:22  UR
57346 2   4  VID  U   0:23  UP   1:23  UR   2:23  UR   3:23  UR
57347 3   4  VID  U   0:24  UP   1:24  UR   2:24  UR   3:24  UR
57348 4   4  VID  U   0:25  UP   1:25  UR   2:25  UR   3:25  UR
57349 5   4  VID  U   0:26  UP   1:26  UR   2:26  UR   3:26  UR
57350 6   4  VID  U   0:27  UP   1:27  UR   2:27  UR   3:27  UR
57351 7   4  VID  U   0:28  UP   1:28  UR   2:28  UR   3:28  UR
57352 8   4  VID  U   0:29  UP   1:29  UR   2:29  UR   3:29  UR
57353 9   4  VID  U   0:30  UP   1:30  UR   2:30  UR   3:30  UR
57354 10  4  VID  U   0:31  UP   1:31  UR   2:31  UR   3:31  UR
-----
```

```
Total number of Replication groups on slot 7/0: 11
```

To verify the sessions on the pilot QAM carrier, use the **show cable video session logical-edge-device id number** command as shown in the example below:

```
Router#show cable video session logical-edge-device id 1
Total Sessions = 22
```

Session Output Id	Output Input Port	Streaming Output Type	Session Encrypt Status	Session Encrypt Type	Destination Session Port	UDP Program	Output State	Input State
1048598	21	Remap	UDP		172.16.0.1	49152 32	ACTIVE-PSI	ON
1104548	1088424	CLEAR	-		bago_tbv.1.21.49152			
1048599	21	Remap	UDP		172.16.0.1	49153 33	ACTIVE-PSI	ON
1104482	1088424	CLEAR	-		bago_tbv.1.21.49153			
1048600	22	Remap	UDP		172.16.0.1	49154 34	ACTIVE-PSI	ON
1104922	1090656	CLEAR	-		bago_tbv.1.22.49154			
1048601	22	Remap	UDP		172.16.0.1	49155 35	ACTIVE-PSI	ON
1105033	1090534	CLEAR	-		bago_tbv.1.22.49155			
1048602	23	Remap	UDP		172.16.0.1	49156 36	ACTIVE-PSI	ON
1114332	1092488	CLEAR	-		bago_tbv.1.23.49156			
1048603	23	Remap	UDP		172.16.0.1	49157 37	ACTIVE-PSI	ON
1104353	1092488	CLEAR	-					

Configuration Examples

The following example configures replication across four RF ports on line card 7/0:

```
configure terminal
cable video
```

```

service-distribution-group sdg replication id 1
rf-port integrated-cable 7/0/0
rf-port integrated-cable 7/0/1
rf-port integrated-cable 7/0/2
rf-port integrated-cable 7/0/3
virtual-carrier-group vcg_replication id 1
virtual-edge-input-ip 172.31.1.1 vrf vrf-name input-port-number 1
rf-channel 21-31 tsid 21-31 output-port-number 21-31
bind-vcg
vcg vcg_replication sdg sdg_replication

```

Feature Information for Replication

Use Cisco Feature Navigator to find information about the platform support and software image support. Cisco Feature Navigator enables you to determine which software images support a specific software release, feature set, or platform. To access Cisco Feature Navigator, go to the <https://cfmng.cisco.com/> link. An account on the Cisco.com page is not required.



Note The following table lists the software release in which a given feature is introduced. Unless noted otherwise, subsequent releases of that software release train also support that feature.

Table 1: Feature Information for Replication

Feature Name	Releases	Feature Information
Replication	Cisco IOS XE Everest 16.6.1	This feature was integrated on the Cisco cBR Series Converged Broadband Routers.

