



Cable Monitoring Feature for Cisco cBR Series Routers

After you configure cable monitoring, the router forwards copies of selected packets on the cable interface to an external LAN analyzer attached to another interface on the Cisco CMTS router. This command can help in troubleshooting network and application problems.



Note This feature does not monitor traffic for the purpose of preventing denial-of-service attacks and other types of network attacks. Even after configuring the cable monitoring feature, the traffic continues to its original destination, and only copies of the selected packets are forwarded to the CALEA server or LAN analyzer.



Note This feature doesn't support line card high availability (LCHA).

Finding Feature Information

Your software release may not support all the features that are documented in this module. For the latest feature information and caveats, see the release notes for your platform and software release. The Feature Information Table at the end of this document provides information about the documented features and lists the releases in which each feature is supported.

Contents

- [Overview of Cable Monitor Command for cBR, on page 2](#)
- [Configuring Cable Monitoring for cBR Routers, on page 2](#)
- [Capturing Sniffed Packets, on page 4](#)
- [Cable Monitor Packet Struct, on page 6](#)
- [Feature Information for Cable Monitoring, on page 7](#)

Overview of Cable Monitor Command for cBR

The **cable monitor** command sends copies of packets for specific types of traffic that is sent over a particular cable interface to a LAN analyzer, for use in troubleshooting network problems. This command can select packets to be forwarded using one or more of the following parameters:

- Either incoming or outbound packets
- Packets that match a specific MAC address (source and destination)
- Packets with a specific Service ID (SID)

Packets can also be timestamped to aid in troubleshooting. The packets are then forwarded out of the specified 10 Gigabit Ethernet port to the LAN analyzer for additional analysis.

The figure below illustrates a LAN packet analyzer attached to a Fast Ethernet port in a DOCSIS two-way configuration.

Figure 1: LAN Packet Analyzer in a DOCSIS Two-Way Configuration

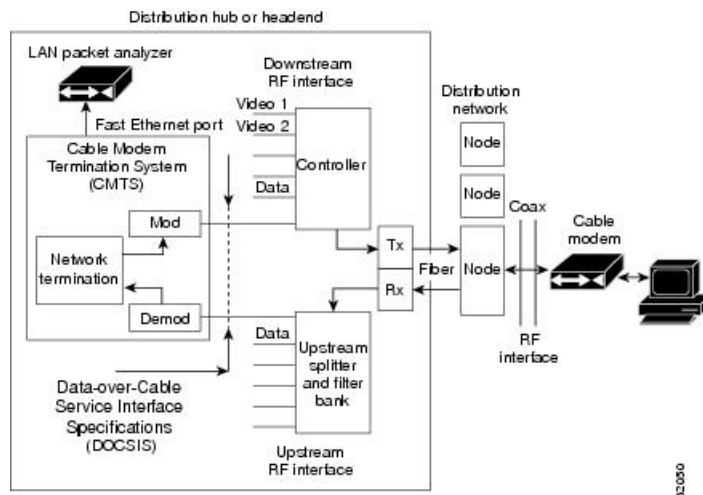

Note The WAN port used for cable monitoring should be exclusively used by the LAN packet analyzer.

Configuring Cable Monitoring for cBR Routers

To enable the cable traffic monitoring feature on a particular cable interface, use the following procedure, starting in privileged EXEC mode.

Procedure

	Command or Action	Purpose
Step 1	enable Example: <pre>Router> enable</pre> Example: <pre>Router#</pre>	Enables privileged EXEC mode. Enter your password if prompted.
Step 2	configure terminal Example: <pre>Router# configure terminal</pre> Example: <pre>Router(config)#</pre>	Enters global configuration mode.
Step 3	cable monitor Example: <pre>Router(config)# cable monitor</pre> Example: <pre>Router(config-cable-monitor)#</pre>	Enters cable monitor configuration mode.
Step 4	sniff card <slot num> <ds/us> <sniff point> <filter> dest cmon-tunnel <cmon-tunnel num> Example: Downstream traffic: For each channel <pre>Router(config-cable-monitor)sniff card 3 outbound docsis integrated-Cable 3/0/0:0 dest cmon-tunnel 3</pre> Example: Downstream traffic: For each wideband channel <pre>Router(config-cable-monitor)sniff card 3 outbound pre-docsis wideband-Cable 3/0/0:0 dest cmon-tunnel 3</pre> Example: Downstream traffic: For each MAC address <pre>Router(config-cable-monitor)sniff card 3 outbound docsis mac-address 0100.5e01.0101 dest cmon-tunnel 3</pre> Example: Upstream traffic: For each channel	Configures the card to forward the sniffed packets. <ul style="list-style-type: none"> • slot number—Slot number of the line card • ds/us—Downstream or upstream • sniff point—Sniff point in downstream or upstream FPGA (field-programmable gate array) • filter—Packet type filter • dest cmon-tunnel—Cable monitor tunnel for captured packets • cmon-tunnel num—Cable monitor tunnel number for capture packets

	Command or Action	Purpose
	<pre>Router(config-cable-monitor)# sniff card 3 incoming post-docsis upstream-cable 3/0/0 us-channel 0 dest cmon-tunnel 3</pre> <p>Example: Upstream traffic: For each MAC address (cable modem or CPE)</p> <pre>Router(config-cable-monitor)#sniff card 3 incoming post-docsis mac-address e448.c70c.9c27 dest cmon-tunnel 3</pre> <p>Example: Upstream traffic: For MD/SID</p> <pre>Router(config-cable-monitor)#sniff card 3 incoming post-docsis cable 3/0/0 sid 12 upstream 0 dest cmon-tunnel 3</pre>	
Step 5	<p>end</p> <p>Example:</p> <pre>Router(config)# end</pre> <p>Example:</p> <pre>Router#</pre>	Exits global configuration mode.

What to do next

You can capture and forward the sniffed packets to an external server or a local hard disk. For more details, see [Capturing Sniffed Packets, on page 4](#).

Capturing Sniffed Packets

To forward the captured traffic to an external server, you should configure a tunnel. The external server might not be directly connected and can be away from CMTS.

To capture sniffed packets, you can follow one of these procedures:

- Capture output packets using an external host
- Capture packets by locating the hard disk

Capturing Sniffed Packets on an External Host

To forward the captured traffic to an external server, you should configure a tunnel. The external server might not be directly connected and can be away from CMTS.

Procedure

	Command or Action	Purpose
Step 1	configure terminal Example: <pre>Router# configure terminal</pre> Example: <pre>Router(config)#</pre>	Enters global configuration mode.
Step 2	interface cmon-tunnel number Example: <pre>Router(config)# interface CMON-Tunnel 3</pre> <pre>Router(config-if)#</pre>	Enters the interface cmon-tunnel mode to capture sniffed packets.
Step 3	tunnel destination IP address, tunnel source IP address Example: <pre>Router(config-if)#tunnel destination</pre> <pre>10.10.21.11</pre> <pre>Router(config-if)#tunnel source</pre> <pre>10.10.21.1</pre>	Configures destination IP address and the source IP address for an external host to capture output packets.
Step 4	end Example: <pre>Router(config)# end</pre> Example: <pre>Router#</pre>	Exits global configuration mode.

Capturing Sniffed Packets on a Local Hard Drive

To forward the captured traffic to a local hard disk, use the following procedure.

Procedure

	Command or Action	Purpose
Step 1	configure terminal Example: <pre>Router#configure CMON-Tunnel 3</pre> Example: <pre>Router(config)#</pre>	Enters global configuration mode.
Step 2	interface cmon-tunnel number Example: <pre>Router(config)#interface CMON-Tunnel 3</pre> <pre>Router(config-if)#</pre>	Enters the interface cmon-tunnel mode.

	Command or Action	Purpose
Step 3	mode buffer Example: Router(config-if)# mode buffer	Enables mode buffer in the cmon-tunnel to capture packets by locating the hard disk.
Step 4	end Example: Router(config-if)# end Router#	Exits global configuration mode.
Step 5	show platform software interface fp active name-string CMON-Tunnel number Example: Router# show platform software interface fp active name-string CMON-Tunnel3 Name: CMON-Tunnel3, ID: 131074, QFP ID: 11745 , Schedules: 0 Type: CABLE-MONITOR, State: enabled, SNMP ID: 0, MTU: 0 IP Address: 0.0.0.0 IPv6 Address: :: Flags: unknown ICMP Flags: unreachable, no-redirects, no-info-reply, no-mask-reply ICMP6 Flags: unreachable, no-redirects SMI enabled on protocol(s): UNKNOWN Authenticated-user: FRR linkdown ID: 65535 Monitor Type: 0, Instance ID: 3, Mode: 3 Monitor Tunnel Source: 0.0.0.0, Destination: 0.0.0.0 vNet Name: , vNet Tag: 0, vNet Extra Information: 0 Dirty: unknown AOM dependency sanity check: PASS AOM Obj ID: 24094	Gets the QFP ID.
Step 6	test platform hardware qfp active feature docsis cmon-copy 3 QFP_ID Example: Router# test platform hardware qfp active feature docsis cmon-copy 3 11745 Router #dir hddisk: in CMON 50 -rw- 24 Mar 5 2020 12:33:42 +02:00 CMON_3_20200305-123342.pcap	Uses the QFP ID to copy the buffer to the hddisk.

Cable Monitor Packet Struct

The cable monitor packet struct is described as follows:

- For post-docsis and pre-docsis sniffer points: Internal Header (16 Bytes) + Ethernet Header
- For docsis sniffer point: Internal Header (16 Bytes) + Docsis Header + Ethernet Header

If **remove-jib** is configured under CMON-Tunnel interface, the packets will not contain Internal Header.

Feature Information for Cable Monitoring

Use Cisco Feature Navigator to find information about the platform support and software image support. Cisco Feature Navigator enables you to determine which software images support a specific software release, feature set, or platform. To access Cisco Feature Navigator, go to the www.cisco.com/go/cfn link. An account on the Cisco.com page is not required.



Note The following table lists the software release in which a given feature is introduced. Unless noted otherwise, subsequent releases of that software release train also support that feature.

Table 1: Feature Information for Cable Monitoring

Feature Name	Releases	Feature Information
Cable Monitoring	Cisco IOS XE Everest 16.6.1	This feature was integrated into Cisco IOS XE Everest 16.6.1 on the Cisco cBR Series Converged Broadband Routers.

