

High CPU Utilization on Cisco IOS Software-Based Catalyst 4500 Switches

[TAC Notice: What's Changing on TAC Web](#)

Contents

[Introduction](#)

[Prerequisites](#)

[Requirements](#)

[Components Used](#)

[Conventions](#)

[Background Information](#)

[Understand the Catalyst 4500 CPU Packet-Handling Architecture](#)

[Identify the Reason for High CPU Utilization on Catalyst 4500](#)

[Baseline the CPU Usage](#)

[Understand the show processes cpu Command on the Catalyst 4500](#)

[Switches](#)

[Understand the show platform health Command on the Catalyst 4500](#)

[Switches](#)

[Troubleshoot Common High CPU Utilization Problems](#)

[High CPU Utilization Due to Process-Switched Packets](#)

[Other Causes of High CPU Utilization](#)

[Troubleshooting Tools to Analyze the Traffic Destined to the CPU](#)

[Tool 1: Monitor the CPU Traffic with SPAN—Cisco IOS Software Release 12.1\(19\)EW and Later](#)

[Tool 2: In-Built CPU Sniffer—Cisco IOS Software Release 12.2\(20\)EW and Later](#)

[Tool 3: Identify the Interface That Sends Traffic to the CPU—Cisco IOS Software Release 12.2\(20\)EW and Later](#)

[Summary](#)

[Cisco Support Community - Featured Conversations](#)

[Related Information](#)

Help us help you.

Please rate this document.

Excellent

Good

Average

Fair

Poor

This document solved my problem.

Yes

No

Just browsing

Suggestions for improvement:

(256 character limit)

Introduction

The Catalyst 4500 series switches, which includes the Catalyst 4948 switches, has a sophisticated packet-handling methodology for CPU-bound traffic. A commonly perceived problem is high CPU utilization on these switches. This document provides details about the CPU packet-handling architecture and shows you how to identify the causes of high CPU utilization on these switches. The document also lists some common network or configuration scenarios that cause high CPU utilization on the Catalyst 4500 series.

Note: If you run Catalyst OS (CatOS)-based Catalyst 4500/4000 series switches, refer to the document [CPU Utilization on Catalyst 4500/4000, 2948G, 2980G, and 4912G Switches That Run CatOS Software](#).

Prerequisites

Requirements

There are no specific requirements for this document.

Components Used

The information in this document is based on these software and hardware versions:

- Catalyst 4500 series switches
- Catalyst 4948 series switches

Note: This document applies only to Cisco IOS® Software-based switches and not CatOS-based switches.

The information in this document was created from the devices in a specific lab environment. All of the devices used in this document started with a cleared (default) configuration. If your network is live, make sure that you understand the potential impact of any command.

Conventions

Refer to [Cisco Technical Tips Conventions](#) for more information on document conventions.

Background Information

Before you look at the CPU packet-handling architecture and troubleshoot high CPU utilization, you must understand the different ways in which hardware-based forwarding switches and Cisco IOS® Software-based routers use the CPU. The common misconception is that high CPU utilization indicates the depletion of resources on a device and the threat of a crash. A capacity issue is one of the symptoms of high CPU utilization on Cisco IOS routers. However, a capacity issue is almost never a symptom of high CPU utilization with hardware-based forwarding switches like the Catalyst 4500. The Catalyst 4500 is designed to forward packets in the hardware application-specific integrated circuit (ASIC) and reach traffic-forwarding speeds of up to 102 million packets per second (Mpps).

The Catalyst 4500 CPU performs these functions:

- Manages configured software protocols, for example:
 - Spanning Tree Protocol (STP)
 - Routing protocol
 - Cisco Discovery Protocol (CDP)
 - Port Aggregation Protocol (PAgP)
 - VLAN Trunk Protocol (VTP)
 - Dynamic Trunking Protocol (DTP)
- Programs configuration/dynamic entries to the hardware ASICs, for example:
 - Access control lists (ACLs)
 - CEF entries
- Internally manages various components, for example:
 - Power over Ethernet (PoE) line cards
 - Power supplies
 - Fan tray
- Manages access to the switch, for example:
 - Telnet

- Console
- Simple Network Management Protocol (SNMP)
- Forwards packets via the software path, for example:
 - Internetwork Packet Exchange (IPX)-routed packets, which are only supported in the software path
 - Maximum transmission unit (MTU) fragmentation

According to this list, high CPU utilization can result from the receipt or process of packets by the CPU. Some of the packets that are sent for process can be essential for the network operation. An example of these essential packets are bridge protocol data unit (BPDUs) for spanning-tree topology configurations. However, other packets can be software-forwarded data traffic. These scenarios require the switching ASICs to send packets to the CPU for processing:

- Packets that are copied to the CPU, but the original packets are switched in hardware

An example is host MAC address learning.

- Packets that are sent to the CPU for processing

Examples include:

- Routing protocol updates
- BPDUs
- An intentional or unintentional flood of traffic
- Packets that are sent to the CPU for forwarding

An example is packets that need IPX or AppleTalk routing.

Understand the Catalyst 4500 CPU Packet-Handling Architecture

The Catalyst 4500 has an in-built quality of service (QoS) mechanism in order to differentiate between types of traffic that are destined to the CPU. The mechanism makes the differentiation on the basis of the Layer 2 (L2)/Layer 3 (L3)/ Layer 4 (L4) packet information. The Supervisor packet Engine has 16 queues in order to handle various types of packets or events. [Figure 1](#) shows these queues. [Table 1](#) lists the queues and the packet types that queue in each. The 16 queues allow the Catalyst 4500 to queue the

packets on the basis of the packet type or priority.

Figure 1 – Catalyst 4500 Uses Multiple CPU Queues

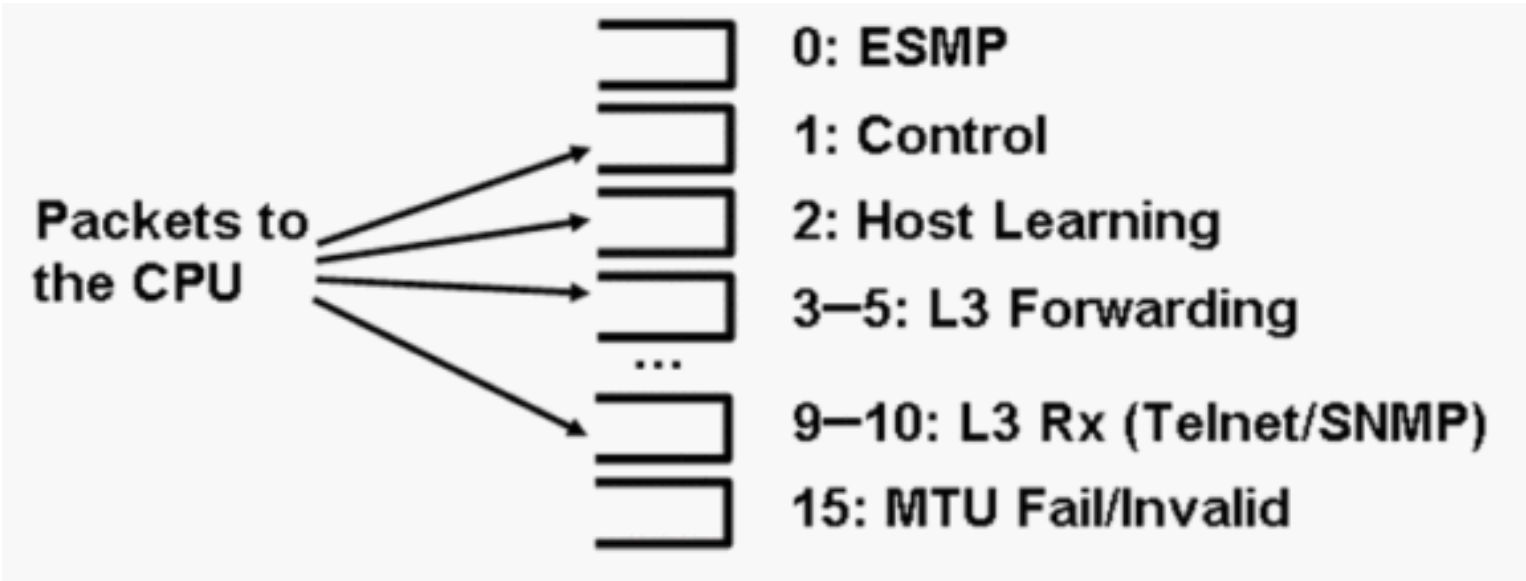

Table 1 – Catalyst 4500 Queue Description

Queue Number	Queue Name	Packets Queued
0	Esmep	ESMP ¹ packets (internal management packets) for the line card ASICs or other component management
1	Control	L2 control plane packets, such as STP, CDP, PAgP, LACP ² , or UDLD ³
2	Host Learning	Frames with unknown source MAC addresses that are copied to the CPU in order to build the L2 forwarding table

3, 4, 5	L3 Fwd Highest, L3 Fwd High/ Medium, L3 Fwd Low	<p>Packets that must be forwarded in software, such as GRE⁴ tunnels</p> <p>If the ARP⁵ is unresolved for the destination IP address, packets are sent to this queue.</p>
6, 7, 8	L2 Fwd Highest, L2 Fwd High/ Medium, L2 Fwd Low	<p>Packets that are forwarded as a result of bridging</p> <ul style="list-style-type: none"> ● Protocols that are not supported in hardware, such as IPX and AppleTalk routed packets, are bridged to the CPU ● ARP request and response ● Packets with a destination MAC address of the switch SVI⁶/L3 interface are bridged if the packets cannot be routed in hardware because of: <ul style="list-style-type: none"> ○ IP header options ○ Expired TTL⁷ ○ Non-ARPA encapsulation
9, 10	L3 Rx High, L3 Rx Low	<p>L3 control plane traffic, for example, routing protocols, that is destined for CPU IP addresses</p> <p>Examples include Telnet, SNMP, and SSH⁸.</p>

11	RPF Failure	Multicast packets that failed the RPF ⁹ check
12	ACL fwd (snooping)	Packets that are processed by the DHCP ¹⁰ snooping, dynamic ARP inspection, or IGMP ¹¹ snooping features
13	ACL log, unreachable	Packets that hit an ACE ¹² with the log keyword or packets that were dropped due to a deny in an output ACL or the lack of a route to the destination These packets require the generation of ICMP unreachable messages.
14	ACL sw processing	Packets that are punted to the CPU due to a lack of additional ACL hardware resources, such as TCAM ¹³ , for security ACL
15	MTU Fail/Invalid	Packets that need to be fragmented because the output interface MTU size is smaller than the size of the packet

¹ ESMP = Even Simple Management Protocol.

² LACP = Link Aggregation Control Protocol.

³ UDLD = UniDirectional Link Detection.

⁴ GRE = generic routing encapsulation.

⁵ ARP = Address Resolution Protocol.

⁶ SVI = switched virtual interface.

⁷ TTL = Time to Live.

⁸ SSH = Secure Shell Protocol.

⁹ RPF = Reverse Path Forwarding

¹⁰ DHCP = Dynamic Host Configuration Protocol.

¹¹ IGMP = Internet Group Management Protocol.

¹² ACE = access control entry.

¹³ TCAM = ternary content addressable memory.

These queues are separate queues:

- L2 Fwd Highest or L3 Fwd Highest
- L2 Fwd High/Medium or L3 Fwd High/Medium
- L2 Fwd Low or L3 Fwd Low
- L3 Rx High or L3 Rx Low

Packets are queued into these queues on the basis of the QoS label, which is the differentiated services code point (DSCP) value from the IP type of service (ToS). For example, packets with a DSCP of 63 are queued to the L3 Fwd Highest queue. You can see the packets that are received and dropped for these 16 queues in the output of the **show platform cpu packet statistics all** command. The output of this command is very long. Issue the **show platform cpu packet statistics** command in order to show only the nonzero events. An alternate command is the **show platform cpuport** command. Only use the **show platform cpuport** command if you run Cisco IOS Software Release 12.1(11)EW or earlier. This command has since been deprecated. However, this older command was a part of the **show tech-support** command in Cisco IOS Software releases earlier than Cisco IOS Software Release 12.2(20)EWA.

Use the **show platform cpu packet statistics** command for all troubleshooting.

```
Switch#show platform cpu packet statistics all
```

```
!--- Output suppressed.
```

```
Total packet queues 16
```

```
Packets Received by Packet Queue
```

Queue	Total		5 sec avg	1 min avg	5
min avg	1 hour avg				

Esmpp			0	0	0
	0	0			
Control			48	0	
0	0	0			
Host Learning			0	0	
0	0	0			
L3 Fwd High			0	0	
0	0	0			
L3 Fwd Medium			0	0	
0	0	0			
L3 Fwd Low			0	0	
0	0	0			
L2 Fwd High			0	0	
0	0	0			
L2 Fwd Medium			0	0	
0	0	0			
L2 Fwd Low			0	0	
0	0	0			
L3 Rx High			0	0	
0	0	0			
L3 Rx Low			0	0	
0	0	0			
RPF Failure			0	0	
0	0	0			
ACL fwd(snooping)			0	0	
0	0	0			
ACL log, unreach			0	0	
0	0	0			
ACL sw processing			0	0	
0	0	0			
MTU Fail/Invalid			0	0	
0	0	0			

Packets Dropped by Packet Queue

Queue	Total		5 sec avg	1 min avg	5
min avg	1 hour avg				

Esm			0	0
0	0	0		
Control			0	0
0	0	0		
Host Learning			0	0
0	0	0		
L3 Fwd High			0	0
0	0	0		
L3 Fwd Medium			0	0
0	0	0		
L3 Fwd Low			0	0
0	0	0		
L2 Fwd High			0	0
0	0	0		
L2 Fwd Medium			0	0
0	0	0		
L2 Fwd Low			0	0
0	0	0		
L3 Rx High			0	0
0	0	0		
L3 Rx Low			0	0
0	0	0		
RPF Failure			0	0
0	0	0		
ACL fwd(snooping)			0	0
0	0	0		
ACL log, unreach			0	0
0	0	0		
ACL sw processing			0	0
0	0	0		
MTU Fail/Invalid			0	0
0	0	0		

The Catalyst 4500 CPU assigns weights to the various queues that [Table 1](#) lists. The CPU assigns the weights on the basis of importance, or type, and on the basis of traffic priority, or DSCP. The CPU services the queue on the basis of the relative weights of the queue. For example, if both a control packet, such as a BPDU, and an ICMP echo request are pending, the CPU services the control packet first. An excessive amount of low-priority or less-important traffic does not starve the CPU of the ability to process or manage the system. This mechanism guarantees that the network is stable even under high utilization of the CPU. This ability of the network to remain stable is critical information that you must understand.

There is another very important implementation detail of Catalyst 4500 CPU packet handling. If the CPU has already serviced high-priority packets or processes but has more spare CPU cycles for a particular time period, the CPU services the low-priority queue packets or performs background processes of lower priority. High CPU utilization as a result of low-priority packet processing or background processes is considered normal because the CPU constantly tries to use all the time available. In this way, the CPU strives for maximum performance of the switch and network without a compromise of the stability of the switch. The Catalyst 4500 considers the CPU underutilized unless the CPU is used at 100 percent for a single time slot.

Cisco IOS Software Release 12.2(25)EWA2 and later have enhanced the CPU packet- and process-handling mechanism and accounting. Therefore, use these releases on your Catalyst 4500 deployments.

Identify the Reason for High CPU Utilization on Catalyst 4500

Now that you understand the Catalyst 4500 CPU packet-handling architecture and design, you may still wish to identify why your Catalyst 4500 CPU utilization is high. The Catalyst 4500 has the commands and tools that are necessary to identify the root cause of the high CPU utilization. After you identify the reason, the administrators can perform either of these actions:

- **Corrective Action**—This can include configuration or network changes, or the creation of a [Cisco Technical Support](#) service request for further analysis.
- **No action**—The Catalyst 4500 performs according to the expectation. The CPU exhibits high CPU utilization because the Supervisor Engine maximizes the CPU cycles in order to perform all the necessary software packet forwarding and background jobs.

Be sure to identify the reason for high CPU utilization even though corrective action is not necessary in all cases. High CPU utilization can be just a symptom of an issue in the network. A resolution of the root cause of that problem can be necessary in order to lower the CPU utilization.

[Figure 2](#) shows the troubleshooting methodology to use in order to identify the root cause of the Catalyst 4500 high CPU utilization.

Figure 2 – High CPU Utilization Troubleshooting Methodology on Catalyst 4500 Switches

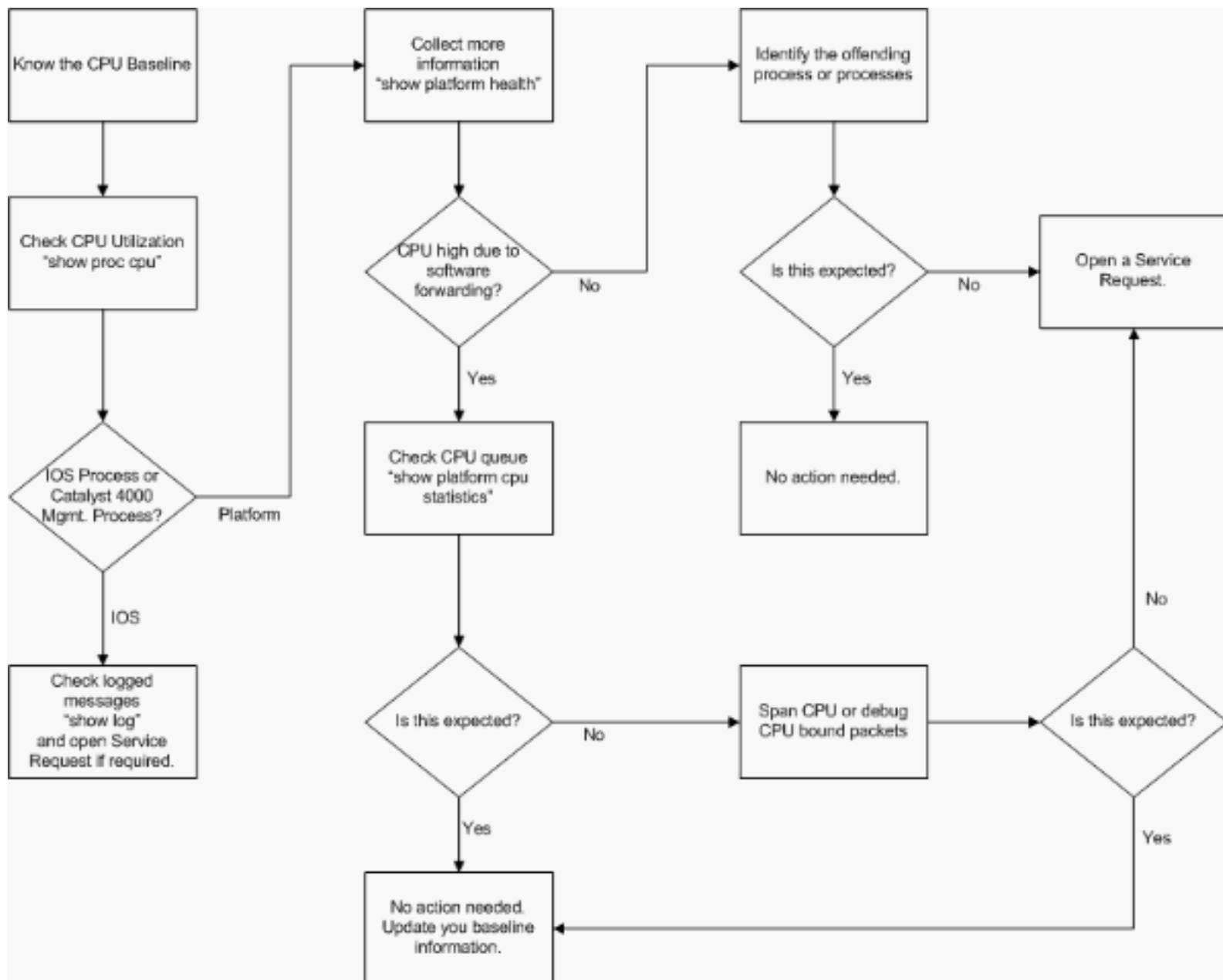

The general troubleshooting steps are:

1. Issue the **show processes cpu** command in order to identify the Cisco IOS processes that consume CPU cycles.
2. Issue the **show platform health** command in order to further identify the platform-specific processes.
3. If the highly active process is **K2CpuMan Review**, issue the **show platform cpu packet statistics** command in order to identify the type of traffic that hits the CPU.

If the activity is not due to the **K2CpuMan Review** process, skip Step 4 and go on to Step 5.

4. Identify the packets that hit the CPU with use of the [Troubleshooting Tools to Analyze the Traffic Destined to the CPU](#), if necessary.

An example of the troubleshooting tools to use is the CPU Switched Port Analyzer (SPAN).

5. Review this document and the section [Troubleshoot Common High CPU Utilization Problems](#) for common causes.

If you still cannot identify the root cause, contact [Cisco Technical Support](#).

Baseline the CPU Usage

The important first step is to know the CPU utilization of your switch for your configuration and network setup. Use the **show processes cpu** command in order to identify the CPU utilization on the Catalyst 4500 switch. The continual update of baseline CPU utilization can be necessary as you add more configuration to the network setup or as your network traffic pattern changes. [Figure 2](#) indicates this requirement.

This output is from a fully loaded Catalyst 4507R. The steady-state CPU is about 32 to 38 percent, which is necessary in order to perform the management functions for this switch:

```
Switch#show processes cpu
CPU utilization for five seconds: 38%/1%; one minute: 32%;
five minutes: 32%
  PID Runtime(ms)   Invoked      uSecs   5Sec   1Min   5Min
TTY Process
  1          0         63          0  0.00%  0.00%  0.00%
0 Chunk Manager
  2         60       50074         1  0.00%  0.00%  0.00%
0 Load Meter
  3          0          1          0  0.00%  0.00%  0.00%
0 Deferred Events

!--- Output suppressed.

 27         524       250268         2  0.00%  0.00%  0.00%
0 TTY Background
 28         816       254843         3  0.00%  0.00%  0.00%
0 Per-Second Jobs
 29       101100        5053      20007  0.00%  0.01%  0.00%
0 Per-minute Jobs
 30     26057260    26720902       975 12.07% 11.41% 11.36%
```

```

0 Cat4k Mgmt HiPri
 31      19482908  29413060          662 24.07% 19.32% 19.20%
0 Cat4k Mgmt LoPri
 32          4468   162748          27  0.00%  0.00%  0.00%
0 Galios Reschedul
 33           0         1           0  0.00%  0.00%  0.00%
0 IOS ACL Helper
 34           0         2           0  0.00%  0.00%  0.00%
0 NAM Manager

```

Five-second CPU utilization is expressed as:

$x\%/y\%$

The $x\%$ represents total CPU utilization, and $y\%$ represents the CPU that is spent at the interrupt level. When you troubleshoot Catalyst 4500 switches, focus only on the total CPU utilization.

Understand the show processes cpu Command on the Catalyst 4500 Switches

This **show processes cpu** output shows that there are two processes that use the CPU— **Cat4k Mgmt HiPri** and **Cat4k Mgmt LoPri** . These two processes aggregate multiple platform-specific processes which perform the essential management functions on the Catalyst 4500. These processes process control plane as well as data packets that need to be software-switched or processed.

In order to see which of the platform-specific processes use the CPU under the context of **Cat4k Mgmt HiPri** and **Cat4k Mgmt LoPri** , issue the **show platform health** command.

Each of the platform-specific processes has a target/expected utilization of the CPU. When that process is within the target, the CPU executes the process in the high-priority context. The **show processes cpu** command output counts that utilization under **Cat4k Mgmt HiPri** . If a process exceeds the target/expected utilization, that process runs under the low-priority context. The **show processes cpu** command output counts that additional utilization under **Cat4k Mgmt LoPri** . This **Cat4k Mgmt LoPri** is also used to run background and other low-priority processes, such as consistency check and reading interface counters. This mechanism allows the CPU to run high-priority processes when necessary, and the idle CPU cycles that remain are used for the low-priority processes. To exceed the target CPU utilization by a small amount, or a momentary spike in utilization, is not an indication of a problem that needs investigation.

```

Switch#show platform health
                                %CPU   %CPU   RunTimeMax   Priority
Average %CPU   Total

```

5Sec	Min	Hour	CPU	Target	Actual	Target	Actual	Fg	Bg
Lj-poll				1.00	0.02	2	1	100	
500	0	0	0	1:09					
GalChassisVp-review				3.00	0.29	10	3	100	
500	0	0	0	11:15					
S2w-JobEventSchedule				10.00	0.32	10	7	100	
500	0	0	0	10:14					
Stub-JobEventSchedul				10.00	12.09	10	6	100	500
14	13	9	396:35						
StatValueMan Update				1.00	0.22	1	0	100	
500	0	0	0	6:28					
Pim-review				0.10	0.00	1	0	100	
500	0	0	0	0:22					
Ebm-host-review				1.00	0.00	8	0	100	
500	0	0	0	0:05					
Ebm-port-review				0.10	0.00	1	0	100	
500	0	0	0	0:01					
Protocol-aging-revie				0.20	0.00	2	0	100	
500	0	0	0	0:00					
Acl-Flattener e				1.00	0.00	10	0	100	
500	0	0	0	0:00					
KxAclPathMan create/				1.00	0.00	10	5	100	
500	0	0	0	0:39					
KxAclPathMan update				2.00	0.00	10	0	100	
500	0	0	0	0:00					
KxAclPathMan reprogr				1.00	0.00	2	0	100	
500	0	0	0	0:00					
TagMan-RecreateMtegR				1.00	0.00	10	0	100	
500	0	0	0	0:00					
K2CpuMan Review				30.00	10.19	30	28	100	500
14	13	9	397:11						
K2AccelPacketMan: Tx				10.00	2.20	20	0	100	
500	2	2	1	82:06					
K2AccelPacketMan: Au				0.10	0.00	0	0	100	
500	0	0	0	0:00					
K2AclMan-taggedFlatA				1.00	0.00	10	0	100	
500	0	0	0	0:00					
K2AclCamMan stale en				1.00	0.00	10	0	100	
500	0	0	0	0:00					
K2AclCamMan hw stats				3.00	1.04	10	5	100	
500	1	1	0	39:36					
K2AclCamMan kx stats				1.00	0.00	10	5	100	

500	0	0	0	13:40							
K2AclCamMan Audit re	1.00	0.00	10	5	100						
500	0	0	0	13:10							
K2AclPolicerTableMan	1.00	0.00	10	1	100						
500	0	0	0	0:38							
K2L2 Address Table R	2.00	0.00	12	5	100						
500	0	0	0	0:00							
K2L2 New Static Addr	2.00	0.00	10	1	100						
500	0	0	0	0:00							
K2L2 New Multicast A	2.00	0.00	10	5	100						
500	0	0	0	0:01							
K2L2 Dynamic Address	2.00	0.00	10	0	100						
500	0	0	0	0:00							
K2L2 Vlan Table Revi	2.00	0.00	12	9	100						
500	0	0	0	0:01							
K2 L2 Destination Ca	2.00	0.00	10	0	100						
500	0	0	0	0:00							
K2PortMan Review	2.00	0.72	15	11	100						
500	1	1	0	37:22							
Gigaport65535 Review	0.40	0.07	4	2	100						
500	0	0	0	3:38							
Gigaport65535 Review	0.40	0.08	4	2	100						
500	0	0	0	3:39							
K2Fib cam usage revi	2.00	0.00	15	0	100	500					
0	0	0	0	0:00							
K2Fib IrmFib Review	2.00	0.00	15	0	100						
500	0	0	0	0:00							
K2Fib Vrf Default Ro	2.00	0.00	15	0	100						
500	0	0	0	0:00							
K2Fib AdjRepop Revie	2.00	0.00	15	0	100						
500	0	0	0	0:00							
K2Fib Vrf Unpunt Rev	2.00	0.01	15	0	100						
500	0	0	0	0:23							
K2Fib Consistency Ch	1.00	0.00	5	2	100						
500	0	0	0	29:25							
K2FibAdjMan Stats Re	2.00	0.30	10	4	100						
500	0	0	0	6:21							
K2FibAdjMan Host Mov	2.00	0.00	10	4	100						
500	0	0	0	0:00							
K2FibAdjMan Adj Chan	2.00	0.00	10	0	100						
500	0	0	0	0:00							
K2FibMulticast Signa	2.00	0.01	10	2	100						
500	0	0	0	2:04							

K2FibMulticast Entry	2.00	0.00	10	7	100
500 0 0 0 0:00					
K2FibMulticast Irm M	2.00	0.00	10	7	100
500 0 0 0 0:00					
K2FibFastDropMan Rev	2.00	0.00	7	0	100
500 0 0 0 0:00					
K2FibPbr route map r	2.00	0.06	20	5	100
500 0 0 0 16:42					
K2FibPbr flat acl pr	2.00	0.07	20	2	100
500 0 0 0 3:24					
K2FibPbr consolidati	2.00	0.01	10	0	100
500 0 0 0 0:24					
K2FibPerVlanPuntMan	2.00	0.00	15	4	100
500 0 0 0 0:00					
K2FibFlowCache flow	2.00	0.01	10	0	100
500 0 0 0 0:23					
K2FibFlowCache flow	2.00	0.00	10	0	100
500 0 0 0 0:00					
K2FibFlowCache adj r	2.00	0.01	10	0	100
500 0 0 0 0:20					
K2FibFlowCache flow	2.00	0.00	10	0	100
500 0 0 0 0:06					
K2MetStatsMan Review	2.00	0.14	5	2	100
500 0 0 0 23:40					
K2FibMulticast MET S	2.00	0.00	10	0	100
500 0 0 0 0:00					
K2QosDbIMan Rate DBL	2.00	0.12	7	0	100
500 0 0 0 4:52					
IrmFibThrottler Thro	2.00	0.01	7	0	100
500 0 0 0 0:21					
K2 VlanStatsMan Revi	2.00	1.46	15	7	100
500 2 2 1 64:44					
K2 Packet Memory Dia	2.00	0.00	15	8	100
500 0 1 1 45:46					
K2 L2 Aging Table Re	2.00	0.12	20	3	100
500 0 0 0 7:22					
RkiosPortMan Port Re	2.00	0.73	12	7	100
500 1 1 1 52:36					
Rkios Module State R	4.00	0.02	40	1	100
500 0 0 0 1:28					
Rkios Online Diag Re	4.00	0.02	40	0	100
500 0 0 0 1:15					
RkiosIpPbr IrmPort R	2.00	0.02	10	3	100

```

500      0      0      0  2:44
RkiosAclMan Review          3.00    0.06      30      0  100
500      0      0      0  2:35
MatMan Review                0.50    0.00       4      0  100
500      0      0      0  0:00
Slot 3 ILC Manager R        3.00    0.00      10      0  100
500      0      0      0  0:00
Slot 3 ILC S2wMan Re        3.00    0.00      10      0  100
500      0      0      0  0:00
Slot 4 ILC Manager R        3.00    0.00      10      0  100
500      0      0      0  0:00
Slot 4 ILC S2wMan Re        3.00    0.00      10      0  100
500      0      0      0  0:00
Slot 5 ILC Manager R        3.00    0.00      10      0  100
500      0      0      0  0:00
Slot 5 ILC S2wMan Re        3.00    0.00      10      0  100
500      0      0      0  0:00
Slot 6 ILC Manager R        3.00    0.00      10      0  100
500      0      0      0  0:00
Slot 6 ILC S2wMan Re        3.00    0.00      10      0  100
500      0      0      0  0:00
Slot 7 ILC Manager R        3.00    0.00      10      0  100
500      0      0      0  0:00
Slot 7 ILC S2wMan Re        3.00    0.00      10      0  100
500      0      0      0  0:00
EthHoleLinecardMan(1       1.66    0.04      10      0  100
500      0      0      0  1:18
EthHoleLinecardMan(2       1.66    0.02      10      0  100
500      0      0      0  1:18
EthHoleLinecardMan(6       1.66    0.17      10      6  100
500      0      0      0  6:38
-----
%CPU Totals                212.80   35.63

```

Understand the show platform health Command on the Catalyst 4500 Switches

The **show platform health** command provides a lot of information that is relevant only for a development engineer. In order to troubleshoot high CPU utilization, look for a higher number in the %CPU actual column in the output. Also, be sure to glance at the right side of that row in order to verify the CPU usage of that process in the 1 minute and 1 hour average %CPU columns. Sometimes, processes momentarily peak but do not hold the CPU for a long time. Some of the momentarily high CPU utilization happens during hardware programming or optimization of the

programming. For example, a spike of CPU utilization is normal during the hardware programming of a large ACL in the TCAM.

In the **show platform health** command output in the section [Understand the show processes cpu Command on the Catalyst 4500 Switches](#), the **Stub-JobEventSchedul** and the **K2CpuMan Review** processes use a higher number of CPU cycles. [Table 2](#) provides some basic information about the common platform-specific processes that appear in the output of the **show platform health** command.

Table 2 – Description of the Platform-Specific Processes from the show platform health Command

Platform-Specific Process Name	Description
Pim-review	Chassis/line card state management
Ebm	Ethernet bridge module, such as aging and monitoring
Acl-Flattener / K2AclMan	ACL merging process
KxAclPathMan - Path TagMan-Review	ACL state management and maintenance
K2CpuMan Review	The process that performs software packet forwarding If you see high CPU utilization due to this process, investigate the packets that hit the CPU with use of the show platform cpu packet statistics command.
K2AccelPacketMan	The driver that interacts with the packet engine in order to send packets that are destined from the CPU

K2Ac1CamMan	Manages the input and output TCAM hardware for QoS and security features
K2Ac1PolicerTableMan	Manages the input and output policers
K2L2	Represents the L2 forwarding subsystem of the Catalyst 4500 Cisco IOS Software These processes are responsible for maintenance of the various L2 tables.
K2PortMan Review	Manages the various port-related programming functions
K2Fib	FIB ¹ management
K2FibFlowCache	PBR ² cache management
K2FibAdjMan	FIB adjacency table management
K2FibMulticast	Manages multicast FIB entries
K2MetStatsMan Review	Manages MET ³ statistics
K2QosDblMan Review	Manages QoS DBL ⁴
IrmFibThrottler Thro	IP routing module
K2 L2 Aging Table Re	Manages the L2 aging function
GalChassisVp-review	Chassis state monitoring
S2w-JobEventSchedule	Manages the S2W ⁵ protocols to monitor line cards state

Stub-JobEventSchedul	Stub ASIC-based line card monitoring and maintenance
RkiosPortMan Port Re	Port state monitoring and maintenance
Rkios Module State R	Line card monitoring and maintenance
EthHoleLinecardMan	Manages GBICs ⁶ in each of the line cards

¹ FIB = Forwarding Information Base.

² PBR = policy-based routing.

³ MET = Multicast Expansion Table.

⁴ DBL = Dynamic Buffer Limiting.

⁵ S2W = serial-to-wire.

⁶ GBIC = Gigabit Interface Converter.

Troubleshoot Common High CPU Utilization Problems

This section covers some of the common high CPU utilization problems on the Catalyst 4500 switches.

High CPU Utilization Due to Process-Switched Packets

One of the common reasons for high CPU utilization is that the Catalyst 4500 CPU is busy with the process of packets for software-forwarded packets or control packets. Examples of software-forwarded packets are IPX or control packets, such as BPDUs. A small number of these packets is typically sent to the CPU. However, a consistently large number of packets can indicate a configuration error or a network event. You must identify the cause of events that lead to the forward of packets to the CPU for processing. This identification enables you to debug the high CPU utilization problems.

Some of the common reasons for high CPU utilization due to process-switched packets are:

- [A high number of spanning-tree port instances](#)

- [ICMP redirects; routing packets on the same interface](#)
- [IPX or AppleTalk routing](#)
- [Host learning](#)
- [Out of hardware resources \(TCAM\) for security ACL](#)
- [The **log** keyword in ACL](#)
- [Layer 2 forwarding loops](#)

Other reasons for the switch of packets to the CPU are:

- MTU fragmentation—Be sure that all interfaces along the path of the packet have the same MTU.
- ACL with TCP flags other than **established**
- IP version 6 (IPv6) routing—This is supported only via the software-switching path.
- GRE—This is supported only via the software-switching path.
- Denial of traffic in the input or output router ACL (RACL)

Note: This is rate-limited in Cisco IOS Software Release 12.1(13)EW1 and later.

Issue the **no ip unreachable** command under the interface of the ACL.

- Excessive ARP and DHCP traffic hits the CPU for processing due to a large number of directly connected hosts

If you suspect a DHCP attack, use DCHP snooping to rate-limit DHCP traffic from any specific host port.

- Excessive SNMP polling by a legitimate or misbehaving end station

A High Number of Spanning-Tree Port Instances

The Catalyst 4500 supports 3000 spanning-tree port instances or active ports in the Per VLAN Spanning Tree+ (PVST+) mode. The support is on all Supervisor Engines, except the Supervisor Engine II+ and II

+TS, and the Catalyst 4948. The Supervisor Engine II+ and II+TS and the Catalyst 4948 support up to 1500 port instances. If you exceed these STP-instance recommendations, the switch exhibits high CPU utilization.

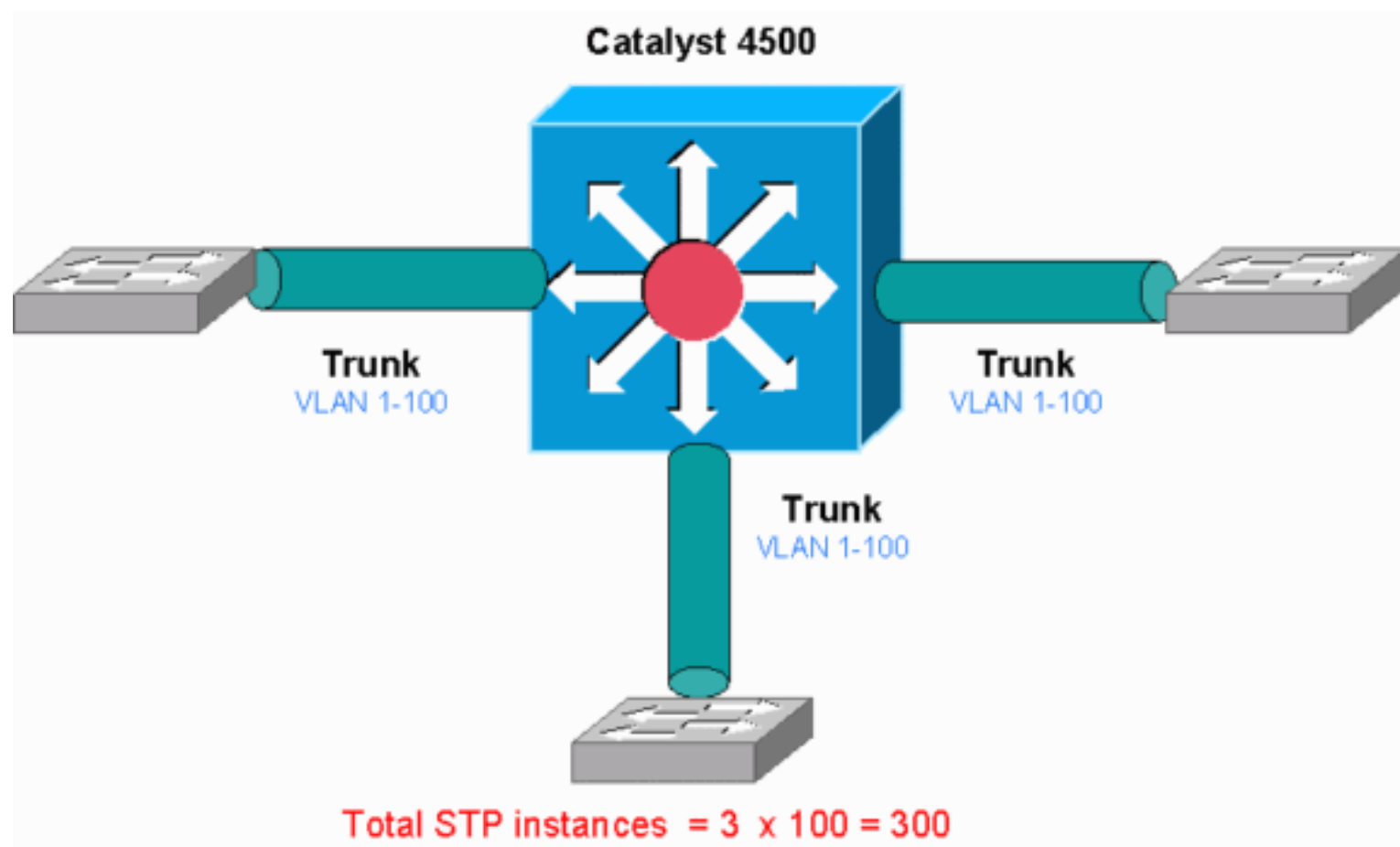

This diagram shows a Catalyst 4500 with three trunk ports that each carry VLANs 1 through 100. This equates to 300 spanning-tree port instances. In general, you can calculate spanning-tree port instances with this formula:

Total number of STP instances = Number of access ports + Sum of all VLANs that are carried in each of the trunks

In the diagram, there are no access ports, but the three trunks carry VLANs 1 through 100:

Total number of STP instances = $0 + 100 + 100 + 100 = 300$

Step 1: Check for the Cisco IOS process with the show processes cpu command.

This section reviews the commands that an administrator uses in order to narrow down the problem of high CPU utilization. If you issue the **show processes cpu** command, you can see that two main processes, **Cat4k Mgmt LoPri** and **Spanning Tree**, primarily use the CPU. With only this

information, you know that the spanning tree process consumes a sizable portion of the CPU cycles.

```
Switch#show processes cpu
```

```
CPU utilization for five seconds: 74%/1%; one minute: 73%;  
five minutes: 50%
```

PID	Runtime(ms)	Invoked	uSecs	5Sec	1Min	5Min
TTY Process						
1	4	198	20	0.00%	0.00%	0.00%
0 Chunk Manager						
2	4	290	13	0.00%	0.00%	0.00%
0 Load Meter						

!--- Output suppressed.

25	488	33	14787	0.00%	0.02%	0.00%
0 Per-minute Jobs						
26	90656	223674	405	6.79%	6.90%	7.22%
0 Cat4k Mgmt HiPri						
27	158796	59219	2681	32.55%	33.80%	21.43%
0 Cat4k Mgmt LoPri						
28	20	1693	11	0.00%	0.00%	0.00%
0 Galios Reschedul						
29	0	1	0	0.00%	0.00%	0.00%
0 IOS ACL Helper						
30	0	2	0	0.00%	0.00%	0.00%
0 NAM Manager						

!--- Output suppressed.

41	0	1	0	0.00%	0.00%	0.00%
0 SFF8472						
42	0	2	0	0.00%	0.00%	0.00%
0 AAA Dictionary R						
43	78564	20723	3791	32.63%	30.03%	17.35%
0 Spanning Tree						
44	112	999	112	0.00%	0.00%	0.00%
0 DTP Protocol						
45	0	147	0	0.00%	0.00%	0.00%
0 Ethchnl						

Step 2: Check for the Catalyst 4500-specific process with the show platform health command.

```
Control          388623      2121
1740           598          16
```

Packets Dropped by Packet Queue

```
Queue          Total          5 sec avg 1 min avg 5
min avg 1 hour avg
-----
Control          17918          0
19           24           3
```

Step 4: Identify the root cause.

Issue the **show spanning-tree summary** command. You can check if the receipt of BPDUs is because of a high number of spanning-tree port instances. The output clearly identifies the root cause:

```
Switch#show spanning-tree summary
Switch is in pvst mode
Root bridge for: none
Extended system ID          is enabled
Portfast Default            is disabled
PortFast BPDU Guard Default is disabled
Portfast BPDU Filter Default is disabled
Loopguard Default          is disabled
EtherChannel misconfig guard is enabled
UplinkFast                  is disabled
BackboneFast                is disabled
Configured Pathcost method used is short
```

!--- Output suppressed.

```
Name          Blocking Listening Learning
Forwarding STP Active
-----
2994 vlans          0          0          0
5999           5999
```

There are a large number of VLANs with the PVST+ mode configuration. In order to resolve the issue, change the STP mode to Multiple Spanning Tree (MST). In some cases, the number of STP instances is high because a high number of VLANs are forwarded on all trunk ports. In this case, manually prune the VLANs that are not necessary from the trunk in order to drop the number of STP active ports to well

below the recommended value.

Tip: Be sure that you do not configure IP phone ports as trunk ports. This is a common misconfiguration. Configure IP phone ports with a voice VLAN configuration. This configuration creates a pseudo trunk, but does not require you to manually prune the unnecessary VLANs. For more information on how to configure voice ports, refer to the [Configuring Voice Interfaces](#) software configuration guide. Non-Cisco IP phones do not support this voice VLAN or auxiliary VLAN configuration. You must manually prune the ports with non-Cisco IP phones.

ICMP Redirects; Routing Packets on the Same Interface

Routing packets on the same interface, or traffic ingress and egress on the same L3 interface, can result in an ICMP redirect by the switch. If the switch knows that the next hop device to the ultimate destination is in the same subnet as the sending device, the switch generates ICMP redirect to the source. The redirect messages indicate to the source to send the packet directly to the next hop device. The messages indicate that the next hop device has a better route to the destination, a route of one less hop than this switch.

In the diagram in this section, PC A communicates with the web server. The default gateway of PC A points to the VLAN 100 interface IP address. However, the next hop router that enables the Catalyst 4500 to reach the destination is in the same subnet as PC A. The best path in this case is to send directly to "Router". Catalyst 4500 sends an ICMP redirect message to PC A. The message instructs PC A to send the packets destined to the web server via Router, instead of via Catalyst 4500. However, in most cases, the end devices do not respond to the ICMP redirect. The lack of response causes the Catalyst 4500 to spend a lot of CPU cycles on the generation of these ICMP redirects for all the packets that the Catalyst forwards via the same interface as the ingress packets.

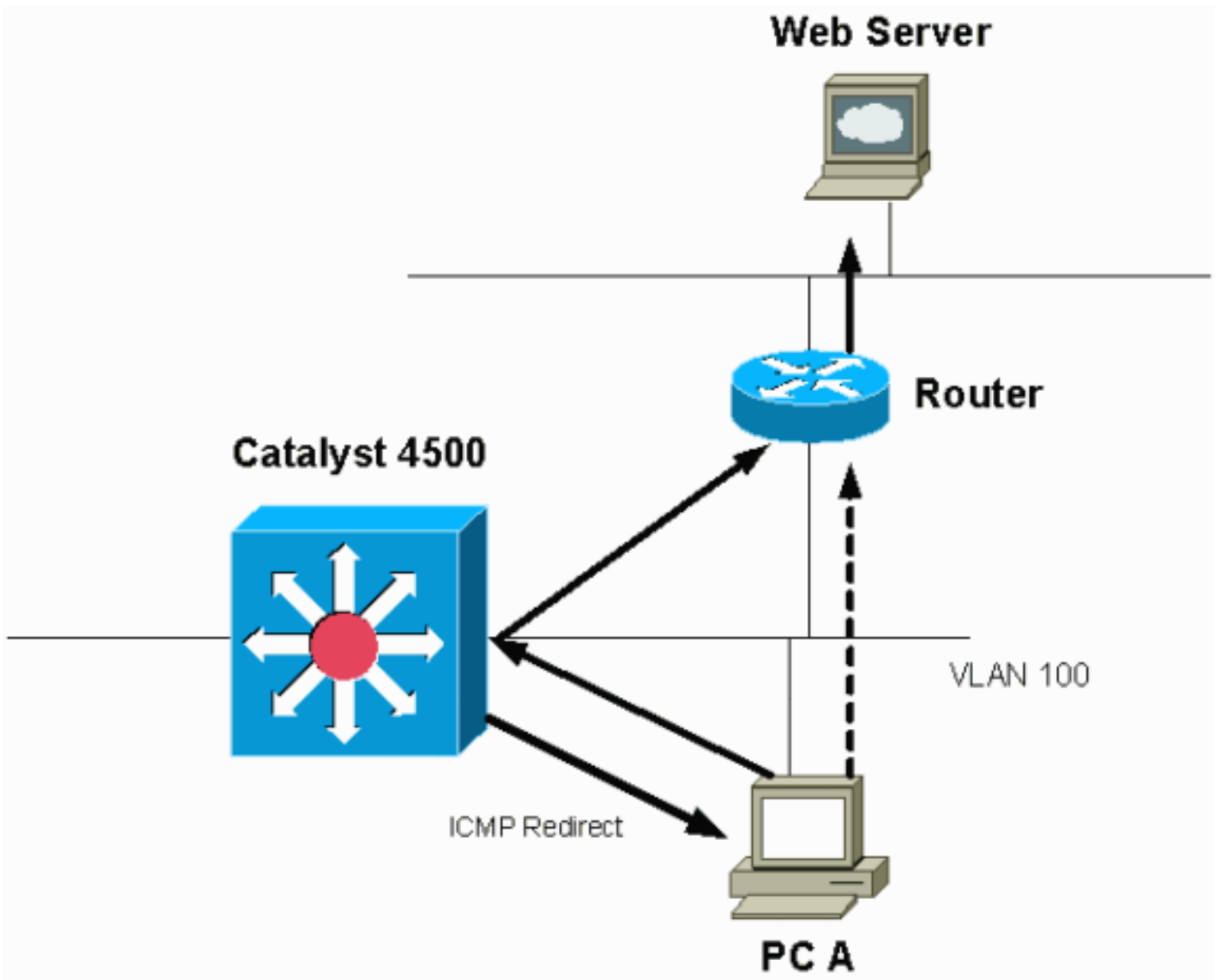

By default, ICMP redirect is enabled. In order to disable it, use the **no ip icmp redirects** command. Issue the command under the relevant SVI or L3 interface.

Note: Since **ip icmp redirects** is a default command, it is not visible in the **show running-configuration** command output.

Step 1: Check for the Cisco IOS process with the show processes cpu command.

Issue the **show processes cpu** command. You can see that two main processes, **Cat4k Mgmt LoPri** and **IP Input**, primarily use the CPU. With only this information, you know that the process of IP packets expends a sizable portion of the CPU.

```
Switch#show processes cpu
CPU utilization for five seconds: 38%/1%; one minute: 32%;
```

five minutes: 32%

PID	Runtime(ms)	Invoked	uSecs	5Sec	1Min	5Min
TTY Process						
1	0	63	0	0.00%	0.00%	0.00%
0 Chunk Manager						
2	60	50074	1	0.00%	0.00%	0.00%
0 Load Meter						
3	0	1	0	0.00%	0.00%	0.00%
0 Deferred Events						

!--- Output suppressed.

27	524	250268	2	0.00%	0.00%	0.00%
0 TTY Background						
28	816	254843	3	0.00%	0.00%	0.00%
0 Per-Second Jobs						
29	101100	5053	20007	0.00%	0.01%	0.00%
0 Per-minute Jobs						
30	26057260	26720902	975	5.81%	6.78%	5.76%
0 Cat4k Mgmt HiPri						
31	19482908	29413060	662	19.64%	18.20%	20.48%
0 Cat4k Mgmt LoPri						

!--- Output suppressed.

35	60	902	0	0.00%	0.00%	0.00%
0 DHCP Snooping						
36	504625304	645491491	781	72.40%	72.63%	73.82%
0 IP Input						

Step 2: Check for the Catalyst 4500-specific process with the show platform health command.

The output of the **show platform health** command confirms the use of the CPU in order to process CPU-bound packets.

```
Switch#show platform health
%CPU   %CPU   RunTimeMax  Priority  Average %CPU  Total
          Target Actual Target Actual  Fg   Bg
5Sec Min Hour  CPU

```

--- Output suppressed.

```

TagMan-RecreateMtegR    1.00    0.00    10      0  100
500    0    0    0  0:00
K2CpuMan Review        330.00 19.18   150     79   25  500
20  19   18 5794:08
K2AccelPacketMan: Tx   10.00    4.95    20      0  100
500    5    4    0  0:36
K2AccelPacketMan: Au    0.10    0.00     0      0  100
500    0    0    0  0:00
K2AclMan-taggedFlatA   1.00    0.00    10      0  100
500    0    0    0  0:00

```

Step 3: Check the CPU queue that receives traffic in order to identify the type of CPU-bound traffic.

Issue the **show platform cpu packet statistics** command in order to check which CPU queue receives the CPU-bound packet. You can see that the L3 Fwd Low queue receives quite a lot of traffic.

```
Switch#show platform cpu packet statistics
```

!--- Output suppressed.

Packets Received by Packet Queue

Queue	Total	5 sec avg	1 min avg	5 min avg	1 hour avg
Esmg	48613268	38			
39	39				
Control	142166648	74			
74	73				
Host Learning	1845568	2			
2	2				
L3 Fwd High	17	0			
0	0				
L3 Fwd Medium	2626	0			
0	0				
L3 Fwd Low	4717094264	3841			
3879	3873	3547			
L2 Fwd Medium	1	0			
0	0				
L3 Rx High	257147	0			
0	0				

L3 Rx Low			5325772	10
19	13	7		
RPF Failure			155	0
0	0	0		
ACL fwd(snooping)			65604591	53
54	54	53		
ACL log, unreach			11013420	9
8	8	8		

Step 4: Identify the root cause.

In this case, use the CPU SPAN in order to determine the traffic that hits the CPU. For information about the CPU SPAN, see the [Tool 1: Monitor the CPU Traffic with SPAN—Cisco IOS Software Release 12.1 \(19\)EW and Later](#) section of this document. Complete an analysis of the traffic and a configuration with use of the **show running-configuration** command. In this case, a packet is routed through the same interface, which leads to the issue of an ICMP redirect for each packet. This root cause is one of the common reasons for high CPU utilization on the Catalyst 4500.

You may expect the sourcing device to act on the ICMP redirect that the Catalyst 4500 sends and change the next hop for the destination. However, not all devices respond to an ICMP redirect. If the device does not respond, the Catalyst 4500 must send redirects for every packet that the switch receives from the sending device. These redirects can consume a great deal of CPU resources. The solution is to disable ICMP redirect. Issue the **no ip redirects** command under the interfaces.

This scenario can occur when you also have configured secondary IP addresses. When you enable the secondary IP addresses, IP redirect is automatically disabled. Be sure you do not manually enable the IP redirects.

As this [ICMP Redirects; Routing Packets on the Same Interface](#) section has indicated, most end devices do not respond to ICMP redirects. Therefore, as a general practice, disable this feature.

IPX or AppleTalk Routing

The Catalyst 4500 supports IPX and AppleTalk routing via software-forwarding path only. With the configuration of such protocols, a higher CPU utilization is normal.

Note: The switching of IPX and AppleTalk traffic in the same VLAN does not require process switching. Only packets that need to be routed require software path forwarding.

Step 1: Check for the Cisco IOS process with the show processes cpu command.

Issue the **show processes cpu** command in order to check which Cisco IOS process consumes the

CPU. In this command output, notice that the top process is the **Cat4k Mgmt LoPri** :

```
witch#show processes cpu
CPU utilization for five seconds: 87%/10%; one minute: 86%;
five minutes: 87%
  PID Runtime(ms)   Invoked      uSecs   5Sec   1Min   5Min
TTY Process
   1         4       53         75  0.00%  0.00%  0.00%
0 Chunk Manager
```

!--- Output suppressed.

```
   25        8008   1329154         6  0.00%  0.00%  0.00%
0 Per-Second Jobs
   26       413128    38493     10732  0.00%  0.02%  0.00%
0 Per-minute Jobs
   27  148288424 354390017         418  2.60%  2.42%  2.77%
0 Cat4k Mgmt HiPri
   28  285796820 720618753         396 50.15% 59.72% 61.31%
0 Cat4k Mgmt LoPri
```

Step 2: Check for the Catalyst 4500-specific process with the show platform health command.

The output of the **show platform health** command confirms the use of the CPU in order to process CPU-bound packets.

```
Switch#show platform health
                %CPU   %CPU   RunTimeMax   Priority
Average %CPU   Total
                Target Actual Target Actual   Fg   Bg
5Sec Min Hour   CPU
```

!--- Output suppressed.

```
TagMan-RecreateMtegR   1.00   0.00    10     4  100
500   0   0   0  0:00
K2CpuMan Review      30.00  27.39    30     53  100  500
42  47  42  4841:
K2AccelPacketMan: Tx  10.00   8.03    20     0  100  500
21  29  26  270:4
```

Step 3: Check the CPU queue that receives traffic in order to identify the type of CPU-

bound traffic.

In order to determine the type of traffic that hits the CPU, issue the **show platform cpu packet statistics** command.

```
Switch#show platform cpu packet statistics
```

```
!--- Output suppressed.
```

Packets Received by Packet Queue

Queue	Total	5 sec avg	1 min avg	5 min avg
min avg 1 hour avg				
-----	-----	-----	-----	-----
Esm	48613268	38		
39	39			
Control	142166648	74		
74	73			
Host Learning	1845568	2		
2	2			
L3 Fwd High	17	0		
0	0			
L3 Fwd Medium	2626	0		
0	0			
L3 Fwd Low	1582414	1		
1	1			
L2 Fwd Medium	1	0		
0	0			
L2 Fwd Low	576905398	1837		
1697	1938	1515		
L3 Rx High	257147	0		
0	0			
L3 Rx Low	5325772	10		
19	13	7		
RPF Failure	155	0		
0	0			
ACL fwd(snooping)	65604591	53		
54	54	53		
ACL log, unreachable	11013420	9		
8	8	8		

Step 4: Identify the root cause.

Since the administrator has configured IPX or AppleTalk routing, identification of the root cause should be straightforward. But in order to confirm, SPAN the CPU traffic and be sure that the traffic that you see is the expected traffic. For information about the CPU SPAN, see the [Tool 1: Monitor the CPU Traffic with SPAN—Cisco IOS Software Release 12.1\(19\)EW and Later](#) section of this document.

In this case, the administrator must update the baseline CPU to the current value. The Catalyst 4500 CPU behaves as expected when the CPU processes software-switched packets.

Host Learning

The Catalyst 4500 learns the MAC addresses of various hosts, if the MAC address is not already in the MAC address table. The switching engine forwards a copy of the packet with the new MAC address to the CPU.

All the VLAN interfaces (layer 3) use the chassis base hardware address as their MAC address. As a result, there is not an entry in the MAC address table, and the packets destined to these VLAN interfaces are not sent to the CPU for processing.

If there is an excessive number of new MAC addresses for the switch to learn, high CPU utilization can result.

Step 1: Check for the Cisco IOS process with the show processes cpu command.

Issue the **show processes cpu** command in order to check which Cisco IOS process consumes the CPU. In this command output, notice that the top process is the **Cat4k Mgmt LoPri**:

```
Switch#show processes cpu
CPU utilization for five seconds: 89%/1%; one minute: 74%;
five minutes: 71%
  PID Runtime(ms)   Invoked      uSecs    5Sec    1Min    5Min
  TTY Process
    1         4         53         75    0.00%   0.00%   0.00%
0 Chunk Manager

!--- Output suppressed.

    25         8008    1329154         6    0.00%   0.00%   0.00%
0 Per-Second Jobs
    26        413128     38493     10732    0.00%   0.02%   0.00%
0 Per-minute Jobs
    27    148288424  354390017     418    26.47%  10.28%  10.11%
```

Control			142166648	74
74	73	73		
Host Learning			1845568	1328
1808	1393	1309		
L3 Fwd High			17	0
0	0	0		
L3 Fwd Medium			2626	0
0	0	0		
L3 Fwd Low			1582414	1
1	1	1		
L2 Fwd Medium			1	0
	0	0	0	
L2 Fwd Low			576905398	37
7	8	5		
L3 Rx High			257147	0
0	0	0		
L3 Rx Low			5325772	10
19	13	7		
RPF Failure			155	0
0	0	0		
ACL fwd(snooping)			65604591	53
54	54	53		
ACL log, unreachable			11013420	9
8	8	8		

Step 4: Identify the root cause.

The output of the **show platform health** command shows you that the CPU sees a lot of new MAC addresses. This situation is often the result of network topology instability. For example, if the spanning-tree topology changes, the switch generates Topology Change Notifications (TCNs). The issue of TCNs reduces the aging time to 15 seconds in PVST+ mode. MAC address entries are flushed if the addresses are not learned back within the time period. In the case of Rapid STP (RSTP) (IEEE 802.1w) or MST (IEEE 802.1s), the entries immediately age out if the TCN comes from another switch. This age out causes MAC addresses to be learned anew. This is not a major issue if the topology changes are rare. But there can be an excessive number of topology changes because of a flapping link, faulty switch, or host ports that are not enabled for PortFast. A large number of MAC table flushes and subsequent relearning can result. The next step in root cause identification is to troubleshoot the network. The switch works as expected and sends the packets to the CPU for host address learning. Identify and fix the faulty device that results in excessive TCNs.

Your network can have a lot of devices that send traffic in bursts, which causes MAC addresses to be aged out and subsequently relearned on the switch. In this case, increase the MAC address table aging time in order to provide some relief. With a longer aging time, the switches retain the device MAC

addresses in the table for a longer period of time before the age out.



Caution: Make this age-out change only after careful consideration. The change can lead to a traffic black hole if you have devices in your network which are mobile.

Out of Hardware Resources (TCAM) for Security ACL

The Catalyst 4500 programs the configured ACLs with use of the Cisco TCAM. TCAM allows for the application of the ACLs in the hardware-forwarding path. There is no impact on performance of the switch, with or without ACLs in the forwarding path. Performance is constant despite the size of the ACL because performance of the ACL lookups is at line rate. However, TCAM is a finite resource. Therefore, if you configure an excessive number of ACL entries, you exceed the TCAM capacity. [Table 3](#) shows the number of TCAM resources available on each of the Catalyst 4500 Supervisor Engines and switches.

Table 3 – TCAM Capacity on Catalyst 4500 Supervisor Engines/Switches

Product	Feature TCAM (per Direction)	QoS TCAM (per Direction)
Supervisor Engine II+/II+TS	8192 entries with 1024 masks	8192 entries with 1024 masks
Supervisor Engine III/IV/V and Catalyst 4948	16,384 entries with 2048 masks	16,384 entries with 2048 masks
Supervisor Engine V-10GE and Catalyst 4948-10GE	16,384 entries with 16,384 masks	16,384 entries with 16,384 masks

The switch uses the feature TCAM in order to program the security ACL, such as RACL and VLAN ACL (VACL). The switch also uses the feature TCAM for security features like IP Source Guard (IPSG) for dynamic ACLs. The switch uses the QoS TCAM in order to program classification and policer ACLs.

When the Catalyst 4500 runs out of TCAM resources during the programming of a security ACL, a partial application of the ACL occurs via the software path. The packets that hit those ACEs are processed in software, which causes high CPU utilization. ACL is programmed from the top down. In other words, if the ACL does not fit into the TCAM, the ACE at the bottom portion of the ACL likely is not programmed in the TCAM.

This warning message appears when a TCAM overflow happens:

```
%C4K_HWACLMAN-4-ACLHWPROGERRREASON: (Suppressed 1times) Input
(null, 12/Normal)
Security: 140 - insufficient hardware TCAM masks.
%C4K_HWACLMAN-4-ACLHWPROGERR: (Suppressed 4 times) Input
Security: 140 - hardware TCAM
limit, some packet processing will be software switched.
```

You can see this error message in the **show logging** command output. The message conclusively indicates that some software processing will take place and, consequently, there can be high CPU utilization.

Note: If you change a large ACL, you can see this message briefly before the changed ACL is programmed again in the TCAM.

Step 1: Check for the Cisco IOS process with the show processes cpu command.

Issue the **show processes cpu** command. You can see that the CPU utilization is high because the **Cat4k Mgmt LoPri** process takes up most of the CPU cycles.

```
Switch#show processes cpu
CPU utilization for five seconds: 99%/0%; one minute: 99%;
five minutes: 99%
  PID Runtime(ms)   Invoked      uSecs   5Sec   1Min   5Min
TTY Process
   1          0         11          0  0.00%  0.00%  0.00%
0 Chunk Manager
   2       9716      632814       15  0.00%  0.00%  0.00%
0 Load Meter
   3         780        302      2582  0.00%  0.00%  0.00%
0 SpanTree Helper

!--- Output suppressed.

  23       18208      3154201        5  0.00%  0.00%  0.00%
0 TTY Background
  24       37208      3942818        9  0.00%  0.00%  0.00%
0 Per-Second Jobs
  25     1046448      110711      9452  0.00%  0.03%  0.00%
0 Per-minute Jobs
```

```

26 175803612 339500656          517  4.12%  4.31%  4.48%
0 Cat4k Mgmt HiPri
27 835809548 339138782          2464 86.81% 89.20% 89.76%
0 Cat4k Mgmt LoPri
28      28668  2058810          13  0.00%  0.00%  0.00%
0 Galios Reschedul

```

Step 2: Check for the Catalyst 4500-specific process with the show platform health command.

Issue the **show platform health** command. You can see that the **K2CpuMan Review**, a job to handle CPU-bound packets, uses the CPU.

```

Switch#show platform health
%CPU   %CPU   RunTimeMax  Priority  Average %CPU  Total
          Target Actual Target Actual   Fg   Bg
5Sec Min Hour  CPU
Lj-poll          1.00  0.01    2      0  100
500   0   0   0  13:45
GalChassisVp-review  3.00  0.20   10     16  100
500   0   0   0  88:44
S2w-JobEventSchedule 10.00  0.57   10     7  100
500   1   0   0  404:22
Stub-JobEventSchedul 10.00  0.00   10     0  100
500   0   0   0  0:00
StatValueMan Update  1.00  0.09    1     0  100
500   0   0   0  91:33
Pim-review        0.10  0.00    1     0  100
500   0   0   0  4:46
Ebm-host-review   1.00  0.00    8     4  100
500   0   0   0  14:01
Ebm-port-review   0.10  0.00    1     0  100
500   0   0   0  0:20
Protocol-aging-revie 0.20  0.00    2     0  100
500   0   0   0  0:01
Acl-Flattener     1.00  0.00   10     5  100
500   0   0   0  0:04
KxAclPathMan create/  1.00  0.00   10     5  100
500   0   0   0  0:21
KxAclPathMan update  2.00  0.00   10     6  100
500   0   0   0  0:05
KxAclPathMan reprogr  1.00  0.00    2     1  100
500   0   0   0  0:00

```

```

TagMan-InformMtegRev  1.00  0.00    5    0  100
500    0    0    0  0:00
TagMan-RecreateMtegR  1.00  0.00   10   14  100
500    0    0    0  0:18
K2CpuMan Review      30.00  91.31   30   92  100  500
128 119   84 13039:02
K2AccelPacketMan: Tx  10.00  2.30   20    0  100
500    2    2    2 1345:30
K2AccelPacketMan: Au   0.10  0.00    0    0  100
500    0    0    0  0:00

```

Step 3: Check the CPU queue that receives traffic in order to identify the type of CPU-bound traffic.

You need to further understand which CPU queue and, therefore, what type of traffic hits the CPU queue. Issue the **show platform cpu packet statistics** command. You can see that the ACL sw processing queue receives a high number of packets. Therefore, TCAM overflow is the cause of this high CPU utilization issue.

```
Switch#show platform cpu packet statistics
```

!--- Output suppressed.

Packets Received by Packet Queue

Queue	Total	5 sec avg	1 min avg	5 min avg	1 hour avg
Control	57902635	22			
16	12	3			
Host Learning	464678	0			
0	0	0			
L3 Fwd Low	623229	0			
0	0	0			
L2 Fwd Low	11267182	7			
4	6	1			
L3 Rx High	508	0			
0	0	0			
L3 Rx Low	1275695	10			
1	0	0			
ACL fwd(snooping)	2645752	0			
0	0	0			

```

ACL log, unreachable          51443268          9
4          5          5
ACL sw processing          842889240          1453
1532          1267          1179

```

Packets Dropped by Packet Queue

```

Queue                          Total          5 sec avg 1 min avg 5
min avg 1 hour avg
-----
L2 Fwd Low                      3270          0
0          0          0
ACL sw processing                12636          0
0          0          0

```

Step 4: Resolve the issue.

In [Step 3](#), you determined the root cause in this scenario. Remove the ACL which caused the overflow or minimize the ACL to avoid overflow. Also, review the [Configuring Network Security with ACLs](#) configuration guideline in order to optimize the ACL configuration and programming in the hardware.

The log Keyword in ACL

The Catalyst 4500 supports logging of packets detail that hit any specific ACL entry, but excessive logging can cause high CPU utilization. Avoid the use of **log** keywords, except during the traffic discovery stage. During the traffic discovery stage, you identify the traffic that flows through your network for which you have not explicitly configured ACEs. Do not use the **log** keyword in order to gather statistics. In Cisco IOS Software Release 12.1(13)EW and later, the **log** messages are rate-limited. If you use **log** messages in order to count the number of packets that match the ACL, the count is not accurate. Instead, use the **show access-list** command for accurate statistics. Identification of this root cause is easier because a review of the configuration or **log** messages can indicate the use of the ACL logging feature.

Step 1: Check for the Cisco IOS process with the show processes cpu command.

Issue the **show processes cpu** in order to check which Cisco IOS process consumes the CPU. In this command output, you find that the top process is the **Cat4k Mgmt LoPri** :

```

Switch#show processes cpu
CPU utilization for five seconds: 99%/0%; one minute: 99%;
five minutes: 99%

```

PID	Runtime(ms)	Invoked	uSecs	5Sec	1Min	5Min
TTY Process						
1	0	11	0	0.00%	0.00%	0.00%
0	Chunk Manager					
2	9716	632814	15	0.00%	0.00%	0.00%
0	Load Meter					

!--- Output suppressed.

26	175803612	339500656	517	4.12%	4.31%	4.48%
0	Cat4k Mgmt HiPri					
27	835809548	339138782	2464	86.81%	89.20%	89.76%
0	Cat4k Mgmt LoPri					
28	28668	2058810	13	0.00%	0.00%	0.00%
0	Galios Reschedul					

Step 2: Check for the Catalyst 4500-specific process with the show platform health command.

Check the platform-specific process that uses the CPU. Issue the **show platform health** command. In the output, notice that the **K2CpuMan Review** process uses most of the CPU cycles. This activity indicates that the CPU is busy as it processes packets destined to it.

```
Switch#show platform health
```

				%CPU	%CPU	RunTimeMax	Priority	
Average %CPU				Target	Actual	Target	Actual	
5Sec	Min	Hour	CPU			Fg	Bg	
Lj-poll				1.00	0.01	2	0	100
500	0	0	0	13:45				
GalChassisVp-review				3.00	0.20	10	16	100
500	0	0	0	88:44				
S2w-JobEventSchedule				10.00	0.57	10	7	100
500	1	0	0	404:22				
Stub-JobEventSchedul				10.00	0.00	10	0	100
500	0	0	0	0:00				
StatValueMan Update				1.00	0.09	1	0	100
500	0	0	0	91:33				
Pim-review				0.10	0.00	1	0	100
500	0	0	0	4:46				
Ebm-host-review				1.00	0.00	8	4	100
500	0	0	0	14:01				
Ebm-port-review				0.10	0.00	1	0	100

```

500      0      0      0      0:20
Protocol-aging-revie  0.20    0.00        2        0    100
500      0      0      0      0:01
Acl-Flattener          1.00    0.00       10        5    100
500      0      0      0      0:04
KxAclPathMan create/   1.00    0.00       10        5    100
500      0      0      0      0:21
KxAclPathMan update   2.00    0.00       10        6    100
500      0      0      0      0:05
KxAclPathMan reprogr  1.00    0.00        2        1    100
500      0      0      0      0:00
TagMan-InformMtegRev  1.00    0.00        5        0    100
500      0      0      0      0:00
TagMan-RecreateMtegR  1.00    0.00       10       14    100
500      0      0      0      0:18
K2CpuMan Review      30.00   91.31       30       92   100   500
128 119   84 13039:02
K2AccelPacketMan: Tx  10.00    2.30       20        0    100
500      2      2      2    1345:30
K2AccelPacketMan: Au   0.10    0.00        0        0    100
500      0      0      0      0:00

```

Step 3: Check the CPU queue that receives traffic in order to identify the type of CPU-bound traffic.

In order to determine the type of traffic that hits the CPU, issue the **show platform cpu packet statistics** command. In this command output, you can see that the receipt of packets is due to the **ACL log** keyword:

```
Switch#show platform cpu packet statistics
```

```
!--- Output suppressed.
```

```
Total packet queues 16
```

```
Packets Received by Packet Queue
```

```

Queue                Total                5 sec avg 1 min avg 5
min avg 1 hour avg
-----
Control                1198701435                35
35                34                35
Host Learning                874391                0

```

```

0          0          0
L3 Fwd High          428          0
0          0          0
L3 Fwd Medium       12745          0
0          0          0
L3 Fwd Low          2420401          0
0          0          0
L2 Fwd High          26855          0
0          0          0
L2 Fwd Medium       116587          0
0          0          0
L2 Fwd Low          317829151          53
41         31         31
L3 Rx High          2371          0
0          0          0
L3 Rx Low           32333361          7
1          2          0
RPF Failure          4127          0
0          0          0
ACL fwd (snooping)  107743299          4
4          4          4
ACL log, unreachable          1209056404          1987
2125          2139          2089

```

Packets Dropped by Packet Queue

```

Queue          Total          5 sec avg 1 min avg 5
min avg 1 hour avg
-----
ACL log, unreachable          193094788          509
362          437          394

```

Step 4: Resolve the issue.

In [Step 3](#), you determined the root cause in this scenario. In order to prevent this problem, remove the **log** keyword from the ACLs. In Cisco IOS Software Release 12.1(13)EW1 and later, the packets are rate-limited so that CPU utilization does not get too high. Use the access list counters as a way to keep track of ACL hits. You can see the access list counters in the **show access-list *acl_id*** command output.

Layer 2 forwarding loops

Layer 2 forwarding loops can be caused by poor implementation of Spanning Tree Protocol (STP) and

various issues that can affect STP.

Step 1: Check for the Cisco IOS process with the show processes cpu command

This section reviews the commands that an administrator uses in order to narrow down the problem of high CPU utilization. If you issue the **show processes cpu** command, you can see that two main processes, **Cat4k Mgmt LoPri** and **Spanning Tree**, primarily use the CPU. With only this information, you know that the spanning tree process consumes a sizable portion of the CPU cycles.

```
Switch#show processes cpu
CPU utilization for five seconds: 74%/1%; one minute: 73%;
five minutes: 50%
  PID Runtime(ms)   Invoked      uSecs   5Sec   1Min   5Min
TTY Process
   1         4       198         20  0.00%  0.00%  0.00%
0 Chunk Manager
   2         4       290         13  0.00%  0.00%  0.00%
0 Load Meter
```

!--- Output suppressed.

```
   25        488        33      14787  0.00%  0.02%  0.00%
0 Per-minute Jobs
   26       90656     223674        405  6.79%  6.90%  7.22%
0 Cat4k Mgmt HiPri
27       158796     59219      2681 32.55% 33.80% 21.43%
0 Cat4k Mgmt LoPri
   28         20      1693         11  0.00%  0.00%  0.00%
0 Galios Reschedul
   29          0         1          0  0.00%  0.00%  0.00%
0 IOS ACL Helper
   30          0         2          0  0.00%  0.00%  0.00%
0 NAM Manager
```

!--- Output suppressed.

```
   41          0         1          0  0.00%  0.00%  0.00%
0 SFF8472
   42          0         2          0  0.00%  0.00%  0.00%
0 AAA Dictionary R
43       78564     20723      3791 32.63% 30.03% 17.35%
0 Spanning Tree
   44        112      999        112  0.00%  0.00%  0.00%
```

```

0 DTP Protocol
  45          0          147          0  0.00%  0.00%  0.00%
0 Ethchnl

```

Step 2: Check for the Catalyst 4500-specific process with the show platform health command

In order to understand which platform-specific process consumes the CPU, issue the **show platform health** command. From this output, you can see that the **K2CpuMan Review** process, a job to handle CPU-bound packets, uses up the CPU:

```

Switch#show platform health
%CPU   %CPU   RunTimeMax  Priority  Average %CPU  Total
        Target Actual Target Actual   Fg   Bg
5Sec  Min Hour   CPU

```

!--- Output suppressed.

```

TagMan-RecreateMtegR   1.00   0.00       10       0   100
500   0   0   0  0:00
K2CpuMan Review      30.00  37.62    30     53 100 500
41  33   1  2:12
K2AccelPacketMan: Tx  10.00   4.95       20       0   100
500   5   4   0  0:36
K2AccelPacketMan: Au   0.10   0.00        0       0   100
500   0   0   0  0:00
K2AclMan-taggedFlatA   1.00   0.00       10       0   100
500   0   0   0  0:00

```

Step 3: Check the CPU queue that receives traffic in order to identify the type of CPU-bound traffic

Issue the **show platform cpu packet statistics** command in order to check which CPU queue receives the CPU-bound packet. The output in this section shows that the control queue receives a lot of packets. Use the information in [Table 1](#) and the conclusion that you drew in [Step 1](#). You can determine that the packets that the CPU processes and the reason for the high CPU utilization is BPDU processing.

```

Switch#show platform cpu packet statistics

```

!--- Output suppressed.

```

Total packet queues 16
Packets Received by Packet Queue

```

Queue			Total	5 sec avg	1 min avg	5 min avg
min avg	1 hour avg					

Esm			202760	196		
173	128	28				
Control			388623	2121		
1740	598	16				

Packets Dropped by Packet Queue

Queue			Total	5 sec avg	1 min avg	5 min avg
min avg	1 hour avg					

Control			17918	0		
19	24	3				

Step 4: Identify the root cause and fix the issue

Generally, you can complete these steps in order to troubleshoot (depending on the situation, some steps are not necessary):

1. Identify the loop.
2. Discover the scope of the loop.
3. Break the loop.
4. Fix the cause for the loop.
5. Restore redundancy.

Each of the steps are explained in detail at [Troubleshooting Forwarding Loops - Troubleshooting STP on Catalyst Switches Running Cisco IOS System Software](#).

Step 5: Implement advanced STP features

- **BDPU Guard**—Secures STP from unauthorized network devices connected to portfast enabled ports. Refer to [Spanning Tree PortFast BPDU Guard Enhancement](#) for more information.

- **Loop Guard**—Increases the stability of layer 2 networks. Refer to [Spanning-Tree Protocol Enhancements using Loop Guard and BPDU Skew Detection Features](#) for more information.
- **Root Guard**—Enforces root bridge placement in the network. Refer to [Spanning Tree Protocol Root Guard Enhancement](#) for more information.
- **UDLD**—Detects unidirectional links and prevents forwarding loops. Refer to [Understanding and Configuring the Unidirectional Link Detection Protocol Feature](#) for more information.

Other Causes of High CPU Utilization

These are some other known causes of high CPU utilization:

- [Excessive link flaps](#)
- [Spikes in CPU utilization due to FIB consistency check](#)
- [High CPU utilization in the **K2FibAdjMan Host Move** process](#)
- [High CPU utilization in the **RkiosPortMan Port Review** process](#)
- [High CPU utilization when connected to an IP phone with the use of trunk ports](#)
- [High CPU Utilization with RSPAN and Layer 3 Control Packets](#)
- Spike during large ACL programming

The spike in CPU utilization occurs during application or removal of a large ACL from an interface.

Excessive Link Flaps

The Catalyst 4500 exhibits high CPU utilization when one or more of the attached links starts to flap excessively. This situation occurs in Cisco IOS Software releases earlier than Cisco IOS Software Release 12.2(20)EWA.

Step 1: Check for the Cisco IOS process with the show processes cpu command.

Issue the **show processes cpu** command in order to check which Cisco IOS process consumes the CPU. In this command output, notice that the top process is the **Cat4k Mgmt LoPri** :

Switch#**show processes cpu**

CPU utilization for five seconds: 96%/0%; one minute: 76%;
five minutes: 68%

PID	Runtime(ms)	Invoked	uSecs	5Sec	1Min	5Min
TTY Process						
1	0	4	0	0.00%	0.00%	0.00%
0 Chunk Manager						
2	9840	463370	21	0.00%	0.00%	0.00%
0 Load Meter						
3	0	2	0	0.00%	0.00%	0.00%
0 SNMP Timers						

!--- Output suppressed.

27	232385144	530644966	437	13.98%	12.65%	12.16%
0 Cat4k Mgmt HiPri						
28	564756724	156627753	3605	64.74%	60.71%	54.75%
0 Cat4k Mgmt LoPri						
29	9716	1806301	5	0.00%	0.00%	0.00%
0 Galios Reschedul						

Step 2: Check for the Catalyst 4500-specific process with the show platform health command.

The output of the **show platform health** command indicates that the **KxAclPathMan create** process uses up the CPU. This process is for internal path creation.

Switch#**show platform health**

Average	%CPU	Total	%CPU	RunTimeMax	Priority			
5Sec	Min	Hour	Target	Actual	Target	Actual	Fg	Bg
Lj-poll			1.00	0.03	2	0	100	
500	0	0	0	9:49				
GalChassisVp-review			3.00	1.11	10	62	100	
500	0	0	0	37:39				
S2w-JobEventSchedule			10.00	2.85	10	8	100	
500	2	2	2	90:00				
Stub-JobEventSchedul			10.00	5.27	10	9	100	
500	4	4	4	186:2				
Pim-review			0.10	0.00	1	0	100	
500	0	0	0	2:51				

Ebm-host-review	1.00	0.00	8	4	100	
500 0 0 0 8:06						
Ebm-port-review	0.10	0.00	1	0	100	
500 0 0 0 0:14						
Protocol-aging-revie	0.20	0.00	2	0	100	
500 0 0 0 0:00						
Acl-Flattener	1.00	0.00	10	5	100	
500 0 0 0 0:00						
KxAclPathMan create/	1.00	69.11	10	5	100	500
42 53 22 715:0						
KxAclPathMan update	2.00	0.76	10	6	100	
500 0 0 0 86:00						
KxAclPathMan reprogr	1.00	0.00	2	1	100	
500 0 0 0 0:00						
TagMan-InformMtegRev	1.00	0.00	5	0	100	
500 0 0 0 0:00						
TagMan-RecreateMtegR	1.00	0.00	10	227	100	
500 0 0 0 0:00						
K2CpuMan Review	30.00	8.05	30	57	100	
500 6 5 5 215:0						
K2AccelPacketMan: Tx	10.00	6.86	20	0	100	
500 5 5 4 78:42						

Step 3: Identify the root cause.

Enable logging for link up/down messages. This logging is not enabled by default. The enablement helps you to narrow down the offending links very quickly. Issue the **logging event link-status** command under all the interfaces. You can use the **interface range** command in order to conveniently enable on a range of interfaces, as this example shows:

```
Switch#configure terminal
```

```
Enter configuration commands, one per line. End with CNTL/Z.
```

```
Switch(config)#interface range gigabitethernet 5/1 - 48
```

```
Switch(config-if-range)#logging event link-status
```

```
Switch(config--if-range)#end
```

```
Switch#show logging
```

```
!--- Output suppressed.
```

```
3w5d: %LINK-3-UPDOWN: Interface GigabitEthernet5/24, changed  
state to down
```

```
3w5d: %LINK-3-UPDOWN: Interface GigabitEthernet5/24, changed
```

```

state to up
3w5d: %LINK-3-UPDOWN: Interface GigabitEthernet5/24, changed
state to down
3w5d: %LINK-3-UPDOWN: Interface GigabitEthernet5/24, changed
state to up
3w5d: %LINK-3-UPDOWN: Interface GigabitEthernet5/24, changed
state to down
3w5d: %LINK-3-UPDOWN: Interface GigabitEthernet5/24, changed
state to up

```

After you have identified the faulty or flapping interface, shut down the interface in order to resolve the high CPU utilization issue. Cisco IOS Software Release 12.2(20)EWA and later have improved the Catalyst 4500 behavior for this flapping-links condition. Therefore, the impact on the CPU is not as great as before the improvement. Remember that this process is a background process. High CPU utilization because of this issue does not cause adverse effects on the Catalyst 4500 switches.

Spikes in CPU Utilization Due to FIB Consistency Check

The Catalyst 4500 can show momentary spikes in the CPU utilization during a FIB table consistency check. The FIB table is the L3 forwarding table that the CEF process creates. The consistency check maintains consistency between the Cisco IOS Software FIB table and the hardware entries. This consistency ensures that packets are not misrouted. The check occurs every 2 seconds and runs as a low-priority background process. This process is normal behavior and does not interfere with other high-priority processes or packets.

The output of the **show platform health** command shows that **K2Fib Consistency Ch** consumes most of the CPU.

Note: The average CPU utilization for this process is insignificant over a minute or an hour, which confirms that the check is a short periodic review. This background process only uses the idle CPU cycles.

```

Switch#show platform health
                    %CPU   %CPU   RunTimeMax   Priority
Average %CPU   Total
                    Target Actual Target Actual   Fg   Bg
5Sec Min Hour   CPU
Lj-poll          1.00   0.02     2         1  100
500    0    0    0  1:09
GalChassisVp-review  3.00   0.29    10         3  100
500    0    0    0  11:15

```

!--- Output suppressed.

```

K2Fib cam usage revi    2.00    0.00    15      0  100  500
  0  0  0  0:00
K2Fib IrmFib Review    2.00    0.00    15      0  100
500  0  0  0  0:00
K2Fib Vrf Default Ro   2.00    0.00    15      0  100
500  0  0  0  0:00
K2Fib AdjRepop Revie   2.00    0.00    15      0  100
500  0  0  0  0:00
K2Fib Vrf Unpunt Rev   2.00    0.01    15      0  100
500  0  0  0  0:23
K2Fib Consistency Ch   1.00   60.40     5      2  100
500  0  0  0 100:23
K2FibAdjMan Stats Re   2.00    0.30    10      4  100
500  0  0  0  6:21
K2FibAdjMan Host Mov   2.00    0.00    10      4  100
500  0  0  0  0:00
K2FibAdjMan Adj Chan   2.00    0.00    10      0  100
500  0  0  0  0:00
K2FibMulticast Signa   2.00    0.01    10      2  100
500  0  0  0  2:04

```

High CPU Utilization in the K2FibAdjMan Host Move Process

The Catalyst 4500 can display high CPU utilization in the **K2FibAdjMan Host Move** process. This high utilization appears in the output of the **show platform health** command. Many MAC addresses frequently expire or are learned on new ports, which causes this high CPU utilization. The default value of mac-address-table aging-time is 5 minutes or 300 seconds. The workaround for this issue is to increase the MAC address aging time, or you can engineer the network in order to avoid the high number of MAC address moves. Cisco IOS Software Release 12.2(18)EW and later have enhanced this process behavior in order to consume less CPU. Refer to Cisco bug ID [CSCed15021](#)  ([registered](#) customers only) .

```

Switch#show platform health
                %CPU    %CPU    RunTimeMax    Priority
Average %CPU  Total
                Target Actual Target Actual    Fg    Bg
5Sec Min Hour  CPU
Lj-poll        1.00    0.02     2         1  100
500  0  0  0  1:09
GalChassisVp-review  3.00    0.29    10         3  100
500  0  0  0  11:15
S2w-JobEventSchedule 10.00    0.32    10         7  100
500  0  0  0  10:14

```

!--- Output suppressed.

```
K2FibAdjMan Stats Re    2.00    0.30        10        4    100
500    0    0    0    6:21
K2FibAdjMan Host Mov    2.00    18.68        10        4    100
500    25    29    28    2134:39
K2FibAdjMan Adj Chan    2.00    0.00        10        0    100
500    0    0    0    0:00
K2FibMulticast Signa    2.00    0.01        10        2    100
500    0    0    0    2:04
K2FibMulticast Entry    2.00    0.00        10        7    100
500    0    0    0    0:00
```

You can modify the maximum aging time of a MAC address in the global configuration mode. The command syntax is **mac-address-table aging-time seconds** for a router and **mac-address-table aging-time seconds [vlan vlan-id]** for a Catalyst Switch. For more information, refer to the [Cisco IOS Switching Services Command Reference Guide](#).

High CPU Utilization in the RkiosPortMan Port Review Process

The Catalyst 4500 can display high CPU utilization in the **RkiosPortMan Port Review** process in the output of the **show platform health** command in Cisco IOS Software Release 12.2(25)EWA and 12.2(25)EWA1. Cisco bug ID [CSCeh08768](#)  ([registered](#) customers only) causes the high utilization, which Cisco IOS Software Release 12.2(25)EWA2 resolves. This process is a background process and does not affect the stability of the Catalyst 4500 switches.

```
Switch#show platform health
                                     %CPU    %CPU    RunTimeMax    Priority
Average %CPU  Total
                                     Target Actual Target Actual    Fg    Bg
5Sec Min Hour  CPU
Lj-poll
500    0    0    0    1:09
GalChassisVp-review    3.00    0.29    10    3    100
500    0    0    0    11:15
S2w-JobEventSchedule    10.00    0.32    10    7    100
500    0    0    0    10:14
```

!--- Output suppressed.

```
K2 Packet Memory Dia    2.00    0.00        15        8    100
500    0    1    1    45:46
```

```

K2 L2 Aging Table Re 2.00 0.12 20 3 100
500 0 0 0 7:22
RkiosPortMan Port Re 2.00 87.92 12 7 100 500
99 99 89 1052:36
Rkios Module State R 4.00 0.02 40 1 100
500 0 0 0 1:28
Rkios Online Diag Re 4.00 0.02 40 0 100
500 0 0 0 1:15

```

High CPU Utilization When Connected to an IP Phone with the Use of Trunk Ports

If a port is configured for both the voice VLAN option and the access VLAN option, the port acts as a multi-VLAN access port. The advantage is that only those VLANs that are configured for the voice and access VLAN options are trunked.

The VLANs that are trunked to the phone increase the number of STP instances. The switch manages the STP instances. Management of the increase in STP instances also increases the STP CPU utilization.

The trunking of all the VLANs also causes unnecessary broadcast, multicast, and unknown unicast traffic to hit the phone link.

```

Switch#show processes cpu
CPU utilization for five seconds: 69%/0%; one minute: 72%;
five minutes: 73%
  PID Runtime(ms)   Invoked      uSecs   5Sec   1Min   5Min
  TTY Process
    1          4         165        24  0.00%  0.00%  0.00%
0 Chunk Manager
    2       29012      739091        39  0.00%  0.00%  0.00%
0 Load Meter
    3       67080      13762       4874  0.00%  0.00%  0.00%
0 SpanTree Helper
    4          0          1          0  0.00%  0.00%  0.00%
0 Deferred Events
    5          0          2          0  0.00%  0.00%  0.00%
0 IpSecMibTopN
    6    4980144     570766       8725  0.00%  0.09%  0.11%
0 Check heaps
   26   539173952  530982442      1015 13.09% 13.05% 13.20%
0 Cat4k Mgmt HiPri
   27   716335120  180543127      3967 17.61% 18.19% 18.41%
0 Cat4k Mgmt LoPri
   33    1073728     61623      17424  0.00%  0.03%  0.00%

```

0	Per-minute Jobs						
34	1366717824	231584970	5901	38.99%	38.90%	38.92%	
0	Spanning Tree						
35	2218424	18349158	120	0.00%	0.03%	0.02%	
0	DTP Protocol						
36	5160	369525	13	0.00%	0.00%	0.00%	
0	Ethchnl						
37	271016	2308022	117	0.00%	0.00%	0.00%	
0	VLAN Manager						
38	958084	3965585	241	0.00%	0.01%	0.01%	
0	UDLD						
39	1436	51011	28	0.00%	0.00%	0.00%	
0	DHCP Snooping						
40	780	61658	12	0.00%	0.00%	0.00%	
0	Port-Security						
41	1355308	12210934	110	0.00%	0.01%	0.00%	
0	IP Input						

High CPU Utilization with RSPAN and Layer 3 Control Packets

Layer 3 control packets that are captured with RSPAN are destined to CPU rather than just the RSPAN destination interface, which causes high CPU. The L3 control packets are captured by static CAM entries with forward to CPU action. The static CAM entries are global to all VLANs. In order to avoid unnecessary CPU flooding, use the Per-VLAN Control Traffic Intercept feature, available in Cisco IOS software releases 12.2(37)SG and later.

```
Switch(config)# access-list hardware capture mode vlan
```

Static ACLs are installed at the top in input feature TCAM to capture control packets destined to well known IP multicast addresses in the 224.0.0.* range. Static ACLs are installed at boot time and appear before any user configured ACL. Static ACLs are always hit first and intercept control traffic to CPU on all VLANs.

Per-VLAN control traffic intercept feature provide selective per-VLAN path managed mode of capturing control traffic. The corresponding static CAM entries in input feature TCAM are invalidated in the new mode. Control packets are captured by feature specific ACL attached to VLANs on which snooping or routing features are enabled. There is no feature specific ACL attached to RSPAN VLAN. Therefore, all layer 3 control packets received from RSPAN VLAN are not forwarded to CPU.

Troubleshooting Tools to Analyze the Traffic Destined to the CPU

As this document has shown, traffic that is destined to the CPU is one of the major causes of high CPU utilization on the Catalyst 4500. The CPU-destined traffic can be either intentional because of the configuration, or unintentional because of misconfiguration or a denial-of-service attack. The CPU has an in-built QoS mechanism to prevent any adverse network effects because of this traffic. However, identify the root cause of CPU-bound traffic and eliminate the traffic if it is undesirable.

Tool 1: Monitor the CPU Traffic with SPAN—Cisco IOS Software Release 12.1 (19)EW and Later

The Catalyst 4500 allows for the monitor of the CPU-bound traffic, either ingress or egress, with the use of the standard SPAN function. The destination interface connects to a packet monitor or an administrator laptop that runs packet sniffer software. This tool helps to quickly and accurately analyze the traffic that the CPU processes. The tool provides the ability to monitor individual queues that are bound to the CPU packet engine.

Note: The switching engine has 32 queues for the CPU traffic, and the CPU packet engine has 16 queues.

```
Switch(config)#monitor session 1 source cpu ?
  both      Monitor received and transmitted traffic
  queue     SPAN source CPU queue
  rx        Monitor received traffic only
  tx        Monitor transmitted traffic only
  <cr>
Switch(config)#monitor session 1 source cpu queue ?
  <1-32>    SPAN source CPU queue numbers
  acl       Input and output ACL [13-20]
  adj-same-if  Packets routed to the incoming interface
[7]
  all       All queues [1-32]
  bridged   L2/bridged packets [29-32]
  control-packet  Layer 2 Control Packets [5]
  mtu-exceeded  Output interface MTU exceeded [9]
  nfl       Packets sent to CPU by netflow (unused)
[8]
  routed    L3/routed packets [21-28]
  rpf-failure  Multicast RPF Failures [6]
  span      SPAN to CPU (unused) [11]
  unknown-sa  Packets with missing source address [10]
Switch(config)#monitor session 1 source cpu queue all rx
Switch(config)#monitor session 1 destination interface
gigabitethernet 1/3
Switch(config)#end
4w6d: %SYS-5-CONFIG_I: Configured from console by console
```



```
Switch#show monitor session 1
Session 1
-----
Type                : Local Session
Source Ports        :
    RX Only         : CPU
Destination Ports   : Gi1/3
    Encapsulation   : Native
        Ingress     : Disabled
        Learning    : Disabled
```

If you connect a PC that runs a sniffer program, you can quickly analyze the traffic. In the output that appears in the window in this section, you can see that the cause of the high CPU utilization is an excessive number of STP BPDUs.

Note: STP BPDUs in the CPU sniffer is normal. But if you see more than you expect, you may have exceeded the recommended limits for your Supervisor Engine. See the [A High Number of Spanning-Tree Port Instances](#) section of this document for more information.

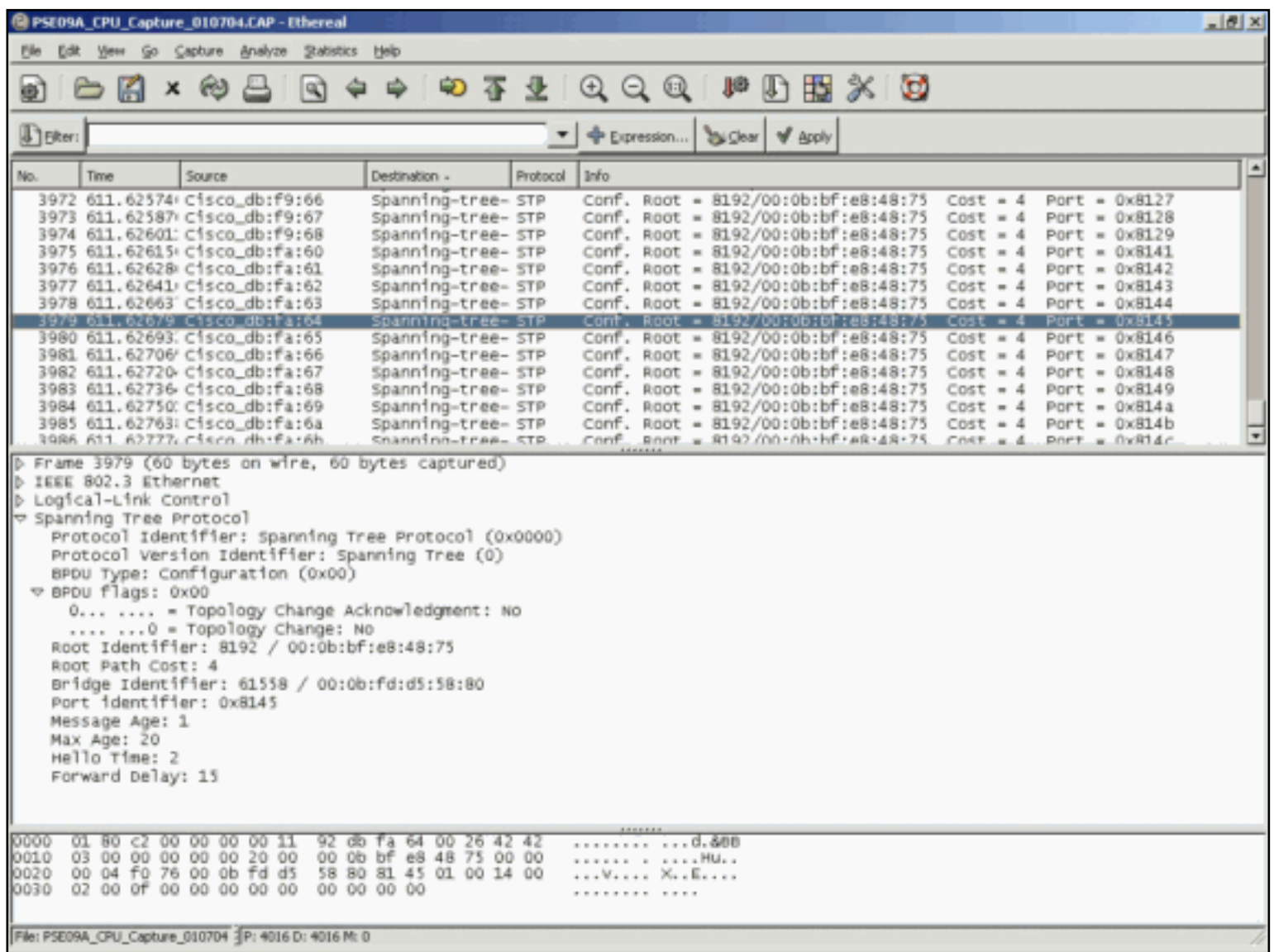

Tool 2: In-Built CPU Sniffer—Cisco IOS Software Release 12.2(20)EW and Later

The Catalyst 4500 provides an in-built CPU sniffer and decoder to quickly identify the traffic that hits the CPU. You can enable this facility with the **debug** command, as the example in this section shows. This feature implements a circular buffer that can retain 1024 packets at a time. As new packets arrive, they overwrite the older packets. This feature is safe to use when you troubleshoot high CPU utilization issues.

```
Switch#debug platform packet all receive buffer
```

```
platform packet debugging is on
```

```
Switch#show platform cpu packet buffered
```

```
Total Received Packets Buffered: 36
```

```
-----  
Index 0:
```

```
7 days 23:6:32:37214 - RxVlan: 99, RxPort: Gi4/48
```

```
Priority: Crucial, Tag: Dot1Q Tag, Event: Control Packet,
```

```

Flags: 0x40, Size: 68
Eth: Src 00-0F-F7-AC-EE-4F Dst 01-00-0C-CC-CC-CD Type/Len
0x0032
Remaining data:
 0: 0xAA 0xAA 0x3 0x0 0x0 0xC 0x1 0xB 0x0 0x0
10: 0x0 0x0 0x0 0x80 0x0 0x0 0x2 0x16 0x63 0x28
20: 0x62 0x0 0x0 0x0 0x0 0x80 0x0 0x0 0x2 0x16
30: 0x63 0x28 0x62 0x80 0xF0 0x0 0x0 0x14 0x0 0x2
40: 0x0 0xF 0x0 0x0 0x0 0x0 0x0 0x2 0x0 0x63

```

```

Index 1:
7 days 23:6:33:180863 - RxVlan: 1, RxPort: Gi4/48
Priority: Crucial, Tag: Dot1Q Tag, Event: Control Packet,
Flags: 0x40, Size: 68

```

```

Eth: Src 00-0F-F7-AC-EE-4F Dst 01-00-0C-CC-CC-CD Type/Len
0x0032
Remaining data:
 0: 0xAA 0xAA 0x3 0x0 0x0 0xC 0x1 0xB 0x0 0x0
10: 0x0 0x0 0x0 0x80 0x0 0x0 0x2 0x16 0x63 0x28
20: 0x62 0x0 0x0 0x0 0x0 0x80 0x0 0x0 0x2 0x16
30: 0x63 0x28 0x62 0x80 0xF0 0x0 0x0 0x14 0x0 0x2
40: 0x0 0xF 0x0 0x0 0x0 0x0 0x0 0x2 0x0 0x63

```

Note: The CPU utilization when you issue a **debug** command is always almost 100%. It is normal to have high CPU utilization when you issue a **debug** command.

Tool 3: Identify the Interface That Sends Traffic to the CPU—Cisco IOS Software Release 12.2(20)EW and Later

Catalyst 4500 provides another useful tool to identify the top interfaces that send traffic/packets for CPU processing. This tool helps you quickly identify an errand device that sends a high number of broadcast or other denial-of-service attacks to the CPU. This feature is also safe to use when you troubleshoot high CPU utilization issues.

```

Switch#debug platform packet all count
platform packet debugging is on
Switch#show platform cpu packet statistics

```

!--- Output suppressed.

Packets Transmitted from CPU per Output Interface

Interface	Total	5 sec avg	1 min avg	5 min avg	1 hour avg

```

-----
-----
Gi4/47                1150                1
5                    10                0
Gi4/48                50                1
0                    0                0

```

Packets Received at CPU per Input Interface

```

Interface                Total                5 sec avg 1 min avg 5
min avg 1 hour avg
-----
-----
Gi4/47                23130                5
10                    50                20
Gi4/48                50                1
0                    0                0

```

Note: The CPU utilization when you issue a **debug** command is always almost 100%. It is normal to have high CPU utilization when you issue a **debug** command.

Summary

The Catalyst 4500 switches handle a high rate of IP version 4 (IPv4) packet forwarding in hardware. Some of the features or exceptions can cause the forward of some packets via the CPU process path. The Catalyst 4500 uses a sophisticated QoS mechanism to handle CPU-bound packets. This mechanism ensures reliability and stability of the switches and, at the same time, maximizes the CPU for the software forwarding of packets. Cisco IOS Software Release 12.2(25)EWA2 and later provide additional enhancements for packet/process handling as well as accounting. The Catalyst 4500 also has sufficient commands and powerful tools to aid in the identification of the root cause of high CPU-utilization scenarios. But, in most cases, high CPU utilization on the Catalyst 4500 is not a cause of network instability nor a cause for concern.

Cisco Support Community - Featured Conversations

[Cisco Support Community](#) is a forum for you to ask and answer questions, share suggestions, and collaborate with your peers. Below are just some of the most recent and relevant conversations happening right now.

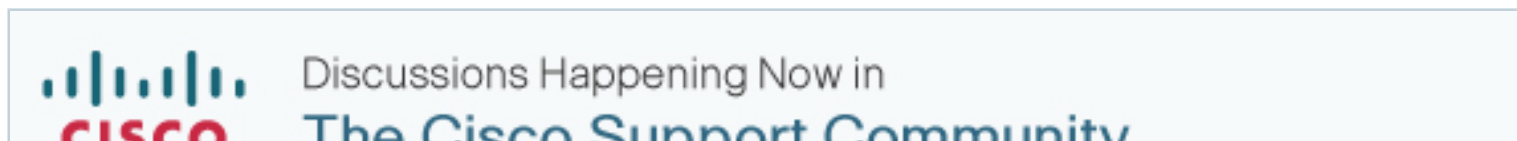

Want to see more? Join us by clicking [here](#)

•
[High CPU Utilization on Cisco IOS...](#)**pramod.prasad5 Replies**2 years, 8 months ago

•
[High CPU utilization on Cisco 4500...](#)**andrewswanson7 Replies**1 year, 6 months ago

•
[Process causes high CPU utilization on...](#)**dsalamanca5 Replies**3 years, 4 months ago

•
[HIGH UTILIZATION of 4500 Catalyst...](#)**sohaildxbfze2 Replies**1 year, 9 months ago

•
[High CPU utilization in 4500](#)**vaibhav-g1 Reply**3 months, 6 days ago

•
[High CPU utilization on Catalyst 3500...](#)**hestholmt1 Reply**7 years, 6 months ago

•
[High CPU Utilization](#)**heidemat011 Reply**3 years, 4 months ago

•
[4507R IOS Catalyst - High CPU...](#)**shakeelahmadch4 Replies**2 years, 7 months ago

•
[4506 CPU utilization average](#)**https://supportforums.cisco.com/people/luiz.alexandre.paiva%40gmail.com6 Replies**2 years, 9 months ago

•
[High CPU Utilization Catalyst 2924](#) **https://supportforums.cisco.com/people/gfiguereo%40bpd.com.do2 Replies**5 years, 11 months ago

[Subscribe](#)  [Start A New Discussion](#)

Related Information

- [CPU Utilization on Catalyst 4500/4000, 2948G, 2980G, and 4912G Switches That Run](#)

CatOS Software

- [LAN Product Support Pages](#)
- [LAN Switching Support Page](#)
- [Technical Support & Documentation - Cisco Systems](#)

Home	How to Buy	Login	Profile	Feedback	Site Map	Help
----------------------	----------------------------	-----------------------	-------------------------	--------------------------	--------------------------	----------------------

[Contacts & Feedback](#) | [Help](#) | [Site Map](#)

© 2008 - 2009 Cisco Systems, Inc. All rights reserved. [Terms & Conditions](#) | [Privacy Statement](#) | [Cookie Policy](#) | [Trademarks of Cisco Systems, Inc.](#)