

GainMaker High Output High Gain Dual 1 GHz System Amplifier 5-85/102-1002 MHz

Consumer bandwidth demand continues to grow at a rapid rate every year. As a result, cable operators with DOCSIS[®]-based equipment have begun introducing fiber deeper and deeper into the network. They want to reduce service group sizes and ultimately double, triple, or quadruple bandwidth speeds. The Cisco[®] GainMaker[®] GaAs High Gain Dual (HGD) System Amplifier is an ideal product for deep fiber applications. With higher output levels, up to 56 dBmV, and significantly improved linearity and performance, this amplifier meets longer reach needs. The GaAs also continues Cisco's legacy of simple, reliable and fast installation and setup. What's more, the Cisco GaAs HGD System Amplifier scales to meet the needs of the HFC network architecture (one product for all amplifier applications).

The GainMaker High Output HGD amplifier provides customers with two forward RF outputs (main and auxiliary), with the option to create a third RF output using an optional plug-in auxiliary path signal director. All Cisco GainMaker products share common plug-in accessories and perform to 1 GHz in the forward path. The system amplifiers in this portfolio provide multiple forward RF output ports while the line extenders provide a single forward RF output port.

Cisco 1 GHz GainMaker system amplifier modules have increased gain to allow drop in for 750-MHz spacing and are mechanically compatible with previous Cisco GainMaker System Amplifier II, II+, and III housing bases, often allowing upgrade to higher bandwidth with no respacing or resplicing. The DC power supply is modular and located in an updated housing lid for easy access. All Cisco 1 GHz GainMaker system amplifier modules are factory configured with reverse amplifier, diplex filters, thermal compensation circuit, forward interstage pads, and equalizer to promote optimal performance. Optional single-pilot automatic gain control (AGC) configurations are also available.



Features

- Capable of higher output levels than standard GainMaker amplifiers
- Common RF test points for forward output and reverse injection simplify reverse balancing
- Increased forward gain to facilitate drop-in bandwidth extensions without re-spacing
- High-performance GaAsFET gain stage technology
- Fixed-value, plug-in accessories are common to all GainMaker products
- 60 and 90 volt AC powering capability
- 15 ampere current capacity (steady state) and 25 ampere surge survivability
- Optional 3-state reverse switch (on/off/-6 dB) allows each reverse input to be isolated for noise and ingress troubleshooting (status monitoring required)
- AGC has Thermal backup, which eliminates disruptive RF output variation in the event of pilot loss
- QAM Pilot AGC now available in addition to existing analog carrier AGCs
- Improved hum modulation
- Plug-in, self-contained diplex filters
- Modular high-efficiency power supply allows simplified maintenance
- Reverse input pad and RF test point for each reverse input port allow optimum reverse path design and alignment
- Directional Coupler RF test points provide greater accuracy
- Surge resistant circuitry helps ensure gain stage protection without fuses or other nuisance failure causing devices

Figure 1. Block Diagram

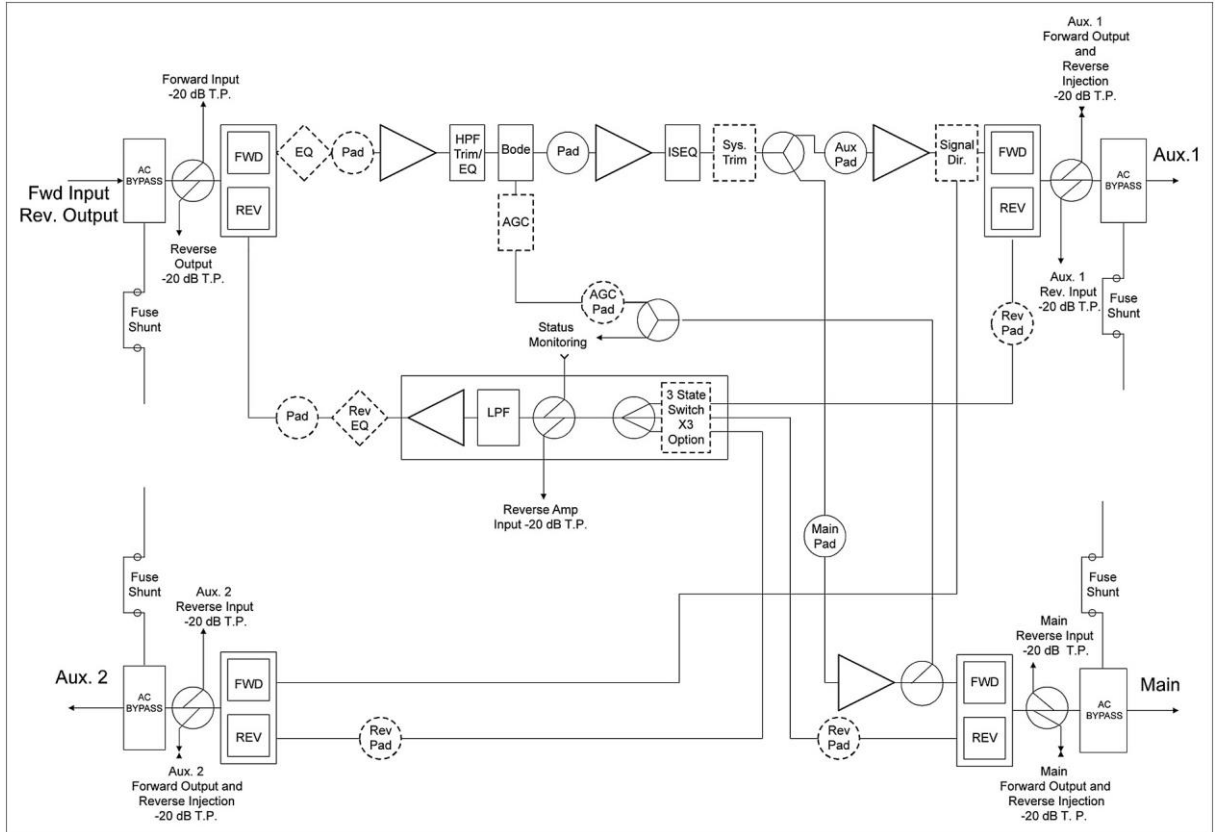

Specifications

General Station Performance	Units	Forward	Reverse	Notes
Pass Band	MHz	105-1002	5-85	10
Amplifier Type	-	GaAs FET	PP	-
Frequency Response	dB	± 0.5	± 0.5	-
Auto Slope and Gain Range	dB	± 5.5	n/a	-
Return Loss	dB	16	16	7
Max AC Through Current (continuous)	Amps	15	-	-
Max AC Through Current (surge)	Amps	25	-	-
Hum Modulation @ 12 A (over specified frequency range)	dB	70 (105-870 MHz) 60 (870-1002 MHz)	60 (5-10 MHz) 70 (11-85 MHz)	-
Hum Modulation @ 15 A (over specified frequency range)	dB	65 (105-870 MHz) 60 (870-1002 MHz)	60 (5-10 MHz) 65 (11-85 MHz)	-
Test Points (± 0.5 dB)	dB	-20	-20	-

Unless otherwise noted, specifications reflect typical performance and are referenced to 68°F (20°C). Specifications are based upon measurements made in accordance with SCTE/ANSI standards (where applicable), using standard frequency assignments.

General Station Performance		Units	Forward	Reverse	Notes
Reference Output Level @...	1002 MHz	dBmV	56.0	35 (@ 42 MHz)	-
	870 MHz		54.0		
	750 MHz		52.2		
	650 MHz		50.5		
	550 MHz		49.0		
	105 MHz		42.3	35 (@ 5 MHz)	
Reference Output Tilt (105-1002 MHz)		dB	13.7	-	1

Forward Station Performance	Units	Auto/Thermal with 10.5 dB I/S EQ	Notes
Operational Gain (minimum)	dB	43	2, 10
Internal Tilt (± 0.5 dB)	dB	13.8	3
Noise Figure @ 54 MHz	dB	8.5	2
Noise Figure @ 1 GHz	dB	8.0	2
78 NTSC channels (CW) with digital			4
Composite Triple Beat	dB	67	9
Cross Modulation	dB	63	5, 9
Composite Second Order (high side)	dB	64	9
Composite Intermodulation Noise (CIN)	dB	60	8, 9

Reverse Station Performance	Units		Notes
Operational Gain (minimum)	dB	19.5	6, 7
Internal Tilt (± 0.5 dB)	dB	-0.5	3
Noise Figure	dB	12	6, 7
6 NTSC Channels (CW)			
Composite Triple Beat	dB	92	9
Cross Modulation	dB	80	5, 9
Composite Second Order (high side)	dB	82	9

Station Delay Characteristics			
Forward (Chrominance to Luminance Delay)		Reverse (Group Delay in 1.5 MHz Bandwidth)	
Frequency (MHz)	Delay (nS)	Frequency (MHz)	Delay (nS)
109.25-112.83	13	5.0-6.5	60
115.25-118.83	7	6.5-8.0	22
121.25-124.83	5	8.0-9.5	12
		80.5-82.0	10
		82.0-83.5	13
		83.5-85.0	18

Unless otherwise noted, specifications reflect typical performance and are referenced to 68°F (20°C). Specifications are based upon measurements made in accordance with SCTE/ANSI standards (where applicable), using standard frequency assignments.

Station Powering Data														
GainMaker High Output HGBT	I DC (Amps)		AC Voltage											
			90	85	80	75	70	65	60	55	50	45	40	35
Thermal	1.7	AC Current (A)	0.74	0.75	0.73	0.73	0.73	0.77	0.93	0.94	1.03	1.14	1.28	1.49
		Power (W)	46.6	46.4	46.0	46.6	46.0	46.0	45.8	45.6	45.8	45.9	46.0	46.4
AGC	1.75	AC Current (A)	0.75	0.77	0.74	0.75	0.75	0.79	0.95	0.97	1.06	1.17	1.33	1.51
		Power (W)	47.9	47.6	47.3	47.3	47.2	47.4	47.0	47.1	47.2	47.2	47.4	46.9
AGC with Status Mon. & Reverse Switch	1.89	AC Current (A)	0.78	0.80	0.78	0.79	0.80	0.85	1.02	1.05	1.14	1.27	1.42	1.65
		Power (W)	51.0	51.0	50.9	51.0	50.8	51.1	50.6	50.7	51.1	50.8	51.1	51.1

Data is based on stations configured for 2-way operation. AC currents specified are based on measurements made with typical CATV type ferroresonant AC power supply (quasi-square wave), and GainMaker High Output System Amplifier power supply (2.5 A, 24 VDC, pn 4022846).

DC supply has a user configurable 30 V, 40 V, or 50 VAC under voltage lockout circuit. Default setting is 30 V. 40 V or 50 V AC under voltage lockout may be selected by changing the position of the lockout jumper.

Notes:

1. Reference output tilt is specified as "LINEAR" tilt (as opposed to "cable" tilt).
2. Forward Gain and Noise Figure measured with 0 dB input EQ and 1 dB input pad.
3. Down tilt, the effect of cable, is represented by a (-). Up tilt, the effect of equalization, is represented by a (+).
4. 73 CW NTSC channels loaded from 115 to 550 MHz. Digital refers to 550-1002 MHz loading with QAM carriers at -6 dB levels relative to analog video carrier levels.
5. X-mod (@ 15.75 kHz) specified using 100% synchronous modulation and frequency selective measurement device.
6. Reverse Gain and Noise Figure for station with 0 dB reverse input pad, 0 dB reverse output EQ, and 1 dB output pad.
7. Reverse Operational Gain, Noise Figure, and Return Loss are specified without reverse switch option. If switch is installed, reduce Gain by 0.5 dB, increase Noise Figure by 0.5 dB, and decrease Return Loss by 1 dB.
8. Composite Intermodulation Noise is a broadband noise-like distortion product associated with QAM loading.
9. Distortion performance at reference output levels and tilt. Contact Cisco Systems Engineering for CIN calculation.
10. The gain at 102 MHz is < 1.5 dB below the gain at 105 MHz. 102 to 105 MHz is recommended for out of band communication only. No video carriers should be used between 102 and 105 MHz.

Environmental	Value
Operating Temperature Range	-40 -140°F (-40 -60°C)
Mechanical	
Housing Dimensions	17.3 in. L x 7.2 in. H x 7.8 in. D 439.4 mm L x 182.9 mm H x 198.1 mm D
Weight	
• Housing with power supply	12 lbs, 5 oz. (5.6 kg)
• Module	5 lbs, 5 oz. (2.4 kg)

Unless otherwise noted, specifications reflect typical performance and are referenced to 68°F (20°C). Specifications are based upon measurements made in accordance with SCTE/ANSI standards (where applicable), using standard frequency assignments.

Ordering Information

The Cisco GainMaker High Gain Dual is available in a wide variety of configurations. The desired configuration is “built” by accessing the Cisco Commerce Workspace tool at <https://cisco-apps.cisco.com/cisco/psn/commerce>. The user specifies the new Assemble To Order (ATO) Product ID for the Cisco GainMaker System Amplifier High Gain Dual “GMSA-HGD” and the tool steps through the available options. Services may also be selected during this process. Once all the desired options are selected, the configuration and price are displayed. When the “Done” radio button is clicked, the configuration can be exported and saved for future use or immediate ordering.

This page contains ordering information for required and optional accessories. Please consult with your Account Representative, Customer Service Representative, or System Engineer to determine the best configuration for your particular application.

The following **Required Accessories** must be ordered separately (not included via GainMaker Ordering Matrix):

Required Accessories	Part Number
Plug-in Pads (attenuators) - Available in 0.5 dB steps from 0 to 20.5 dB <ul style="list-style-type: none"> • 1 required for forward input • 1 required for AGC, if applicable* • 4 required for reverse (3 input, 1 output) <p>* To determine AGC pad value, subtract 34 dB from the design value main port RF output level at the AGC pilot frequency</p>	589693 (0 dB) sequentially thru 589734 (20.5 dB)
Plug-in Forward Cable Equalizer - Available in 1.5 dB steps from 0 to 30 dB at 1002 MHz <ul style="list-style-type: none"> • 1 required for forward input 	4007228 (0 dB) sequentially thru 4007248 (30 dB)
Plug-in Reverse Cable Equalizer - Available in 1 dB steps from 0 to 12 dB at 40 MHz <ul style="list-style-type: none"> • 1 required for reverse output - unless design value is 0 dB (0 dB EQ is provided) 	712719 (0 dB) and 4036769 (1 dB) sequentially thru 4036780 (12 dB)
Plug-In Signal Director for Auxiliary output - 1 required, chose from below: <ul style="list-style-type: none"> • Jumper • 2-way Splitter • DC-8 Directional Coupler • DC-12 Directional Coupler 	4008208 4008364 4008365 4008366

The following **Optional Accessories** may be ordered separately:

Optional Accessories	Part Number
24V Power Supply for GainMaker High Output HGD	4026157
230 V AC Crowbar Surge Protector (plug-in, one per station)	715973
Plug-in Inverse Equalizer. Simulates cable equivalent tilts (creates tilt opposite that of equalizers). Use in place of forward input EQ as needed to maintain proper output tilt in short spaced locations. Available in approx. 1.6 dB “cable equivalent” steps from 1.6 to 16.2 dB.	4007486 (1.6 dB) sequentially thru 4007495 (16.2 dB)
Long Reach Test Point Adapter	562580
Status Monitoring Transponder - see GainMaker Status Monitoring Transponder Data Sheet	Refer to the Cisco GainMaker Status Monitoring Transponder Data Sheet. http://www.cisco.com/c/en/us/product/video/transponders/index.html .

The following **Housing Options** may be included with the product if ordered using the GainMaker Ordering Matrix. They may also be ordered separately.

GainMaker System Amplifier Housing - 1 required Housing includes housing base, lid, wiring harness, and 24 V power supply # 4026157. All Housings have 15 amp capacity.	Part Number
• Uncoated 4 port housing without external test point access	4026387
• Chromate Plated 4 port housing without external test point access	4026388
• Uncoated 4 port housing with external test point access	4026385
• Chromate Plated 4 port housing with external test point access	4026386
GainMaker System Amplifier Housing Upgrade Kit - 1 required if upgrading an existing SA II, II+, or III housing to allow use of GainMaker System Amplifier modules. Includes a GainMaker System Amplifier housing lid, wiring harness, and 24 V power supply # 4022846.	
• Uncoated 4 port housing lid without external test point access	4026389
• Painted 4 port housing lid without external test point access	4026390
• Uncoated 4 port housing lid with external test point access	4026391
• Painted 4 port housing lid with external test point access	4026392
Seizure Upgrade Kit - 1 required if upgrading an existing SAll or SAll+ housing base to allow use of GainMaker System Amplifier Modules. Includes high current (15 amp) rated seizure screws and anvils.	548775

Cisco Systems, Inc.
 1 800 722-2009 or 678 277-1120
<http://www.cisco.com>



Americas Headquarters
 Cisco Systems, Inc.
 San Jose, CA

Asia Pacific Headquarters
 Cisco Systems (USA) Pte. Ltd.
 Singapore

Europe Headquarters
 Cisco Systems International BV Amsterdam,
 The Netherlands

Cisco has more than 200 offices worldwide. Addresses, phone numbers, and fax numbers are listed on the Cisco Website at www.cisco.com/go/offices.

Cisco and the Cisco logo are trademarks or registered trademarks of Cisco and/or its affiliates in the U.S. and other countries. To view a list of Cisco trademarks, go to this URL: www.cisco.com/go/trademarks. Third party trademarks mentioned are the property of their respective owners. The use of the word partner does not imply a partnership relationship between Cisco and any other company. (1110R)