

# Cisco GainMaker GaN High Gain Balanced Triple 1 GHz System Amplifier 5-85/102-1002 MHz

Consumer bandwidth demand continues to grow at a rapid rate every year. As a result, cable operators with DOCSIS<sup>®</sup>-based equipment have begun introducing fiber deeper and deeper into the network. They want to reduce service group sizes and ultimately double or quadruple (or more!) bandwidth speeds. The Cisco<sup>®</sup> GainMaker<sup>®</sup> gallium nitride (GaN) High Gain Balanced Triple (HGBT) System Amplifier is an ideal product for deep fiber applications. Why? Because with higher output levels, up to 58 dBmV, and significantly improved linearity and performance, longer reach needs can be met. The GaN amplifier carries on Cisco's legacy of simple, reliable and fast installation and setup. Furthermore, the Cisco GaN HGBT System Amplifier can scale to meet the needs of all HFC network architecture (one product for all amplifier applications).

The amplifier provides three high-level forward RF outputs - main and auxiliary. All Cisco GainMaker products share common plug-in accessories and perform to 1 GHz in the forward path. The system amplifiers in this portfolio provide multiple forward RF output ports while the line extenders provide a single forward RF output port.

Cisco GainMaker 1 GHz system amplifier modules have increased gain to allow drop in for 750-MHz spacing and are mechanically compatible with previous Cisco GainMaker System Amplifier II, II+, and III housing bases, often allowing upgrade to higher bandwidth with no respacing or resplicing. The DC power supply is modular and located in an updated housing lid for easy access. All Cisco GainMaker 1 GHz system amplifier modules are factory configured with reverse amplifier, diplex filters, thermal compensation circuit, forward interstage pads, and equalizer to promote optimal performance. Optional single-pilot automatic gain control (AGC) configurations are also available.

**Figure 1.** Cisco GainMaker GaN HGBT System Amplifier



## Features

- High-performance GaN gain stage technology
- Plug-in accessories that are common to all Cisco GainMaker nodes and Cisco GS7000 products (i.e., attenuator pads, equalizers, diplexers, and crowbar)
- Amplifier cover that provides access to RF test points
- Power supply mounted in housing lid for efficient thermal dissipation (60- and 90-VAC powering capability)
- 15A current capacity (steady state) and 25A surge survivability
- Optional three-state reverse switch (on/off/-6 dB) that allows each reverse input to be isolated for noise and ingress troubleshooting (status monitoring required)
- Quadrature amplitude modulation (QAM) and analog pilot AGC available (optional)
- AGC with thermal backup, which eliminates disruptive RF output variation in the event of pilot loss
- Reverse input pad and RF test point for each reverse input port to allow optimum reverse path design and alignment
- Surge-resistant circuitry that helps ensure gain stage protection without fuses or other failure-causing devices

**Figure 2.** Block Diagram

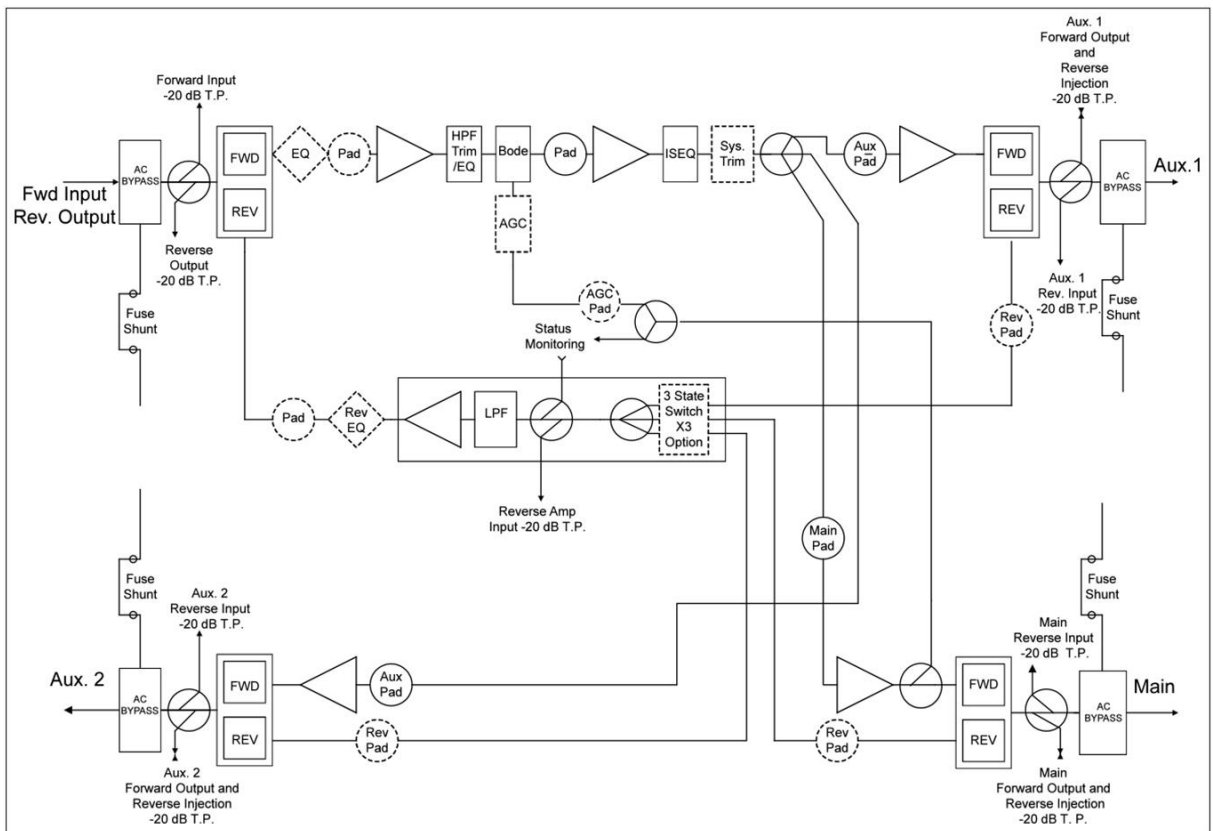

## Specifications

**Table 1.** General Station Performance

General Station Performance	Units	Forward	Reverse	Notes
Pass band	MHz	105-1002	5-85	10
Amplifier type	-	GaAs FET	PP	
Frequency response	dB	± 0.5	± 0.5	
Auto slope and gain range	dB	± 5.5	n/a	
Return loss	dB	16	16	7
Maximum AC through current (continuous)	A	15	-	
Maximum AC through current (surge)	A	25	-	
Hum modulation @ 12A (over specified frequency range)	dB	70 (105-870 MHz) 60 (870-1002 MHz)	60 (5-10 MHz) 70 (11-85 MHz)	
Hum modulation @ 15A (over specified frequency range)	dB	65 (105-870 MHz) 60 (870-1002 MHz)	60 (5-10 MHz) 65 (11-85 MHz)	
Test points (± 0.5 dB)	dB	-20	-20	
Reference output level @	dBmV			
1002 MHz		56.0	35 (@ 85 MHz)	
870 MHz		54.0		
750 MHz		52.2		
650 MHz		50.5		
550 MHz		49.0		
105 MHz		42.3	35 (@ 5 MHz)	
Reference output tilt (105-1002 MHz)	dB	13.7	-	1

**Table 2.** Forward Station Performance

Forward Station Performance	Units	Auto/Thermal with 10.5 dB I/S EQ	Notes
Operational gain (minimum)	dB	42	2, 10
Internal tilt (± 0.5 dB)	dB	13.8	3
Noise figure @ 105 MHz	dB	8.5	2
Noise figure @ 1 GHz	dB	8.0	2
73 NTSC Channels (CW) with digital			4
Composite triple beat	dB	68	9
Cross modulation	dB	63	5,9
Composite second order (high side)	dB	68	9
Composite intermodulation noise (CIN)	dB	59	8,9

Unless otherwise noted, specifications reflect typical performance and are referenced to 68°F (20°C). Specifications are based upon measurements made in accordance with SCTE/ANSI standards (where applicable), using standard frequency assignments.

**Table 3.** Reverse Station Performance

Reverse Station Performance	Units		Notes
Operational gain (minimum)	dB	19.5	6,7
Internal tilt ( $\pm 0.5$ dB)	dB	-0.5	3
Noise figure	dB	12	6,7
<b>6 NTSC Channels (CW)</b>			
Composite triple beat	dB	92	9
Cross modulation	dB	80	5,9
Composite second order (high side)	dB	82	9

**Table 4.** Station Delay Characteristics

Station Delay Characteristics			
Forward (Chrominance to Luminance Delay)		Reverse (Group Delay in 1.5 MHz bandwidth)	
Frequency (MHz)	Delay (ns)	Frequency (MHz)	Delay (ns)
109.25 to 112.83	13	5.0 to 6.5	60
115.25 to 118.83	7	6.5 to 8.0	22
121.25 to 124.83	5	8.0 to 9.5	12
		80.5 to 82.0	10
		82.0 to 83.5	13
		83.5 to 85.0	18

**Table 5.** Station Powering Data

Station Powering Data														
Cisco GainMaker	I DC		AC Voltage											
HGBT	(Amps)		90	85	80	75	70	65	60	55	50	45	40	35
Thermal	1.94	AC current (A)	0.78	0.79	0.78	0.80	0.84	0.88	0.99	1.05	1.16	1.29	1.48	1.74
		Power (W)	52.5	52.4	52.3	52.2	52.0	52.0	51.9	51.9	52.0	52.1	52.3	52.7
AGC	1.98	AC current (A)	0.79	0.80	0.79	0.81	0.85	0.90	1.01	1.08	1.19	1.32	1.51	1.77
		Power (W)	53.6	53.4	53.4	53.2	53.1	53.0	53.0	53.0	53.0	53.1	53.4	53.8
AGC with status monitor and reverse switch	2.12	AC current (A)	0.82	0.85	0.84	0.87	0.89	0.96	1.09	1.16	1.26	1.42	1.62	1.92
		Power (W)	57.3	57.1	57.1	56.9	56.8	56.7	56.7	56.7	56.8	56.9	57.2	57.7

Data is based on stations configured for two-way operation. AC currents specified are based on measurements made with typical CATV type ferroresonant AC power supply (quasi-square wave), and Cisco GainMaker System Amplifier power supply (2.5A, 24 VDC, pn 734771).

DC supply has a user configurable 30V, 40V, or 50 VAC under-voltage lockout circuit. Default setting is 30V. 40V, or 50 VAC. Under-voltage lockout may be selected by changing the position of the lockout jumper.

Unless otherwise noted, specifications reflect typical performance and are referenced to 68°F (20°C). Specifications are based upon measurements made in accordance with SCTE/ANSI standards (where applicable), using standard frequency assignments.

**Notes:**

1. Reference output tilt is specified as "LINEAR" tilt (as opposed to "cable" tilt).
2. Forward gain and noise figure measured with 0 dB input EQ and 1 dB input pad.
3. Down tilt, the effect of cable, is represented by a (-). Up tilt, the effect of equalization, is represented by a (+).
4. 73 CW NTSC channels loaded from 115 to 550 MHz. Digital refers to 550-1002 MHz loading with QAM carriers at -6 dB levels relative to analog video carrier levels.
5. X-mod (@ 15.75 kHz) specified using 100 percent synchronous modulation and frequency selective measurement device.
6. Reverse gain and noise figure for station with 0 dB reverse input pad, 0 dB reverse output EQ, and 1 dB output pad.
7. Reverse operational gain, noise figure, and return loss are specified without reverse switch option. If switch is installed, reduce gain by 0.5 dB, increase noise figure by 0.5 dB, and decrease return loss by 1 dB.
8. Composite intermodulation noise is a broadband noise-like distortion product associated with QAM loading.
9. Distortion performance at reference output levels and tilt. Consult Cisco Systems Engineering for CIN calculation.
10. The gain at 102 MHz is < 1.5 dB below the gain at 105 MHz. 102 to 105 MHz is recommended for out of band communication only. No video carriers should be used between 102 and 105 MHz.

**Table 6.** Physical Specifications

<b>Environmental</b>	
<b>Operating temperature range</b>	-40 to 140°F (-40 to 60°C)
<b>Mechanical</b>	
<b>Housing dimensions (L x H x D)</b>	17.3 in. x 7.2 in. x 7.8 in. (439.4 mm x 182.9 mm x 198.1 mm)
<b>Weight</b>	
• Housing with power supply	12 lb, 5 oz (5.6 kg)
• Module	5 lb, 5 oz (2.4 kg)

Unless otherwise noted, specifications reflect typical performance and are referenced to 68°F (20°C). Specifications are based upon measurements made in accordance with SCTE/ANSI standards (where applicable), using standard frequency assignments.

## Ordering Information

The Cisco GainMaker High Gain Balanced Triple is available in a wide variety of configurations. The desired configuration is “built” by accessing the Cisco Commerce Workspace tool at <https://cisco-apps.cisco.com/cisco/psn/commerce>. The user specifies the new Assemble To Order (ATO) Product ID for the Cisco GainMaker System Amplifier High Gain Balanced Triple “GMSA-HGBT” and the tool steps through the available options, from which to choose. Services may also be selected during this process. Once all the desired options are selected, the configuration and price are displayed. When the “Done” radio button is clicked, the configuration can be exported and saved for future use or immediate ordering.

This page contains ordering information for required and optional accessories. Please consult with your Account Representative, Customer Service Representative, or System Engineer to determine the best configuration for your particular application.

**Table 7.** Required Accessories

Required Accessories	Part Number
<b>Plug-in Pads (attenuators): Available in 0.5 dB steps from 0 to 20.5 dB</b> <ul style="list-style-type: none"> <li>• 1 required for forward input</li> <li>• 1 required for AGC, if applicable*</li> <li>• 4 required for reverse (3 input, 1 output)</li> </ul> <p>* To determine AGC pad value, subtract 34 dB from the design value main port RF output level at the AGC pilot frequency</p>	589693 (0 dB) sequentially through 589734 (20.5 dB)
<b>Plug-in Forward Cable Equalizer: Available in 1.5 dB steps from 0 to 30 dB at 1002 MHz</b> <ul style="list-style-type: none"> <li>• 1 required for forward input</li> </ul>	4007228 (0 dB) sequentially through 4007248 (30 dB)
<b>Plug-in Reverse Cable Equalizer: Available in 1 dB steps from 0 to 12 dB at 85 MHz</b> <ul style="list-style-type: none"> <li>• 1 required for reverse output - unless design value is 0 dB (0 dB EQ is provided)</li> </ul>	712719 (0 dB) and 4036769 (1 dB) sequentially through 4036780 (12 dB)

The optional accessories listed in Table 8 may be ordered separately.

**Table 8.** Optional Accessories

Optional Accessories	Part Number
<b>24V Power Supply for Cisco GainMaker HGBT</b>	734771
<b>230 VAC Crowbar Surge Protector (plug-in, one per station)</b>	4007682
<b>Plug-in Inverse Equalizer: Simulates cable equivalent tilts (creates tilt opposite that of equalizers). Use in place of forward input EQ as needed to maintain proper output tilt in short spaced locations. Available in approximate 1.6 dB “cable equivalent” steps from 1.6 to 16.2 dB.</b>	4007486 (1.6 dB) sequentially through 4007495 (16.2 dB)
<b>Long Reach Test Point Adapter</b>	562580
<b>Status Monitoring Transponder</b>	Refer to the Cisco GainMaker Status Monitoring Transponder Data Sheet. <a href="http://www.cisco.com/c/en/us/products/video/transponders/index.html">http://www.cisco.com/c/en/us/products/video/transponders/index.html</a> .

The housing options listed in Table 9 may be included with the product if ordered using the Cisco GainMaker Ordering Matrix. They may also be ordered separately.

**Table 9.** Housing Options

Cisco GainMaker System Amplifier Housing: 1 required Housing includes housing base, lid, wiring harness, and 24V power supply. All housings have 15A capacity.	Part Number
<ul style="list-style-type: none"> <li>Uncoated 4-port housing without external test point access</li> </ul>	4026387
<ul style="list-style-type: none"> <li>Chromate Plated 4-port housing without external test point access</li> </ul>	4026388
<ul style="list-style-type: none"> <li>Uncoated 4-port housing with external test point access</li> </ul>	4026385
<ul style="list-style-type: none"> <li>Chromate Plated 4-port housing with external test point access</li> </ul>	4026386
<b>Cisco GainMaker System Amplifier Housing Upgrade Kit:</b> 1 required if upgrading an existing System Amplifier II, II+, or III housing to allow use of Cisco GainMaker System Amplifier modules. Includes a Cisco GainMaker System Amplifier housing lid, wiring harness, and 24V power supply # 734771.	
<ul style="list-style-type: none"> <li>Uncoated 4-port housing lid without external test point access</li> </ul>	4026389
<ul style="list-style-type: none"> <li>Painted 4-port housing lid without external test point access</li> </ul>	4026390
<ul style="list-style-type: none"> <li>Uncoated 4-port housing lid with external test point access</li> </ul>	4026391
<ul style="list-style-type: none"> <li>Painted 4-port housing lid with external test point access</li> </ul>	4026392
<b>Seizure Upgrade Kit:</b> 1 required if upgrading an existing Cisco GainMaker System Amplifier II or II+ housing base to allow use of Cisco GainMaker System Amplifier Modules. Includes high current (15A) rated seizure screws and anvils.	548775

Cisco Systems, Inc.  
 1 800 722-2009 or 678 277-1120  
<http://www.cisco.com>



Americas Headquarters  
 Cisco Systems, Inc.  
 San Jose, CA

Asia Pacific Headquarters  
 Cisco Systems (USA) Pte. Ltd.  
 Singapore

Europe Headquarters  
 Cisco Systems International BV Amsterdam,  
 The Netherlands

Cisco has more than 200 offices worldwide. Addresses, phone numbers, and fax numbers are listed on the Cisco Website at [www.cisco.com/go/offices](http://www.cisco.com/go/offices).

Recycling symbol: Cisco and the Cisco logo are trademarks or registered trademarks of Cisco and/or its affiliates in the U.S. and other countries. To view a list of Cisco trademarks, go to this URL: [www.cisco.com/go/trademarks](http://www.cisco.com/go/trademarks). Third party trademarks mentioned are the property of their respective owners. The use of the word partner does not imply a partnership relationship between Cisco and any other company. (1110R)