

Cisco Catalyst 3850 Series Switches

The Cisco[®] Catalyst[®] 3850 Series is the next generation of enterprise-class stackable access-layer switches that provide full convergence between wired and wireless on a single platform. Cisco's new Unified Access Data Plane (UADP) application-specific integrated circuit (ASIC) powers the switch and enables uniform wired plus wireless policy enforcement, application visibility, and application optimization. This convergence is built on the resilience of the new and improved Cisco StackWise-480. The Cisco Catalyst 3850 Series Switches support full IEEE 802.3at Power over Ethernet Plus (PoE+), Cisco Universal Power over Ethernet (UPOE), modular and field-replaceable network modules, redundant fans, and power supplies.

Product Overview

- Integrated wireless controller capability with:
 - Up to 40G of wireless capacity per switch (48 port models)
 - Up to 50 access points (APs) and 2000 wireless clients support on each switching entity (switch or stack)
- 24 and 48 10/100/1000 data and Power over Ethernet Plus (PoE+) models with Energy Efficient Ethernet (EEE)
 - Cisco StackWise[®]-480 technology provides scalability and resiliency with 480 Gbps of stack throughput
 - Cisco StackPower[™] technology provides power stacking among stack members for power redundancy
 - Three optional uplink modules with 4 x Gigabit Ethernet, 2 x 10 Gigabit Ethernet or 4 x 10 Gigabit Ethernet ports
 - Dual redundant, modular power supplies and three modular fans providing redundancy
 - Full IEEE 802.3at (PoE+) with 30W power on all ports in 1 rack unit (RU) form factor
 - Cisco Universal Power over Ethernet (UPOE) which delivers up to 60W per port over standard cabling infrastructure
- Software support for IPv4 and IPv6 routing, Multicast routing, modular quality of service (QoS), Flexible NetFlow (FnF) Version 9, and enhanced security features
- Single Universal IOS image across all license levels, providing an easy upgrade path for software features
- Enhanced limited lifetime warranty (E-LLW) with next business day (NBD) advance hardware replacement and 90-day access to Cisco Technical Assistance Center (TAC) support

Benefits

Converged Wired plus Wireless Access

The Cisco Catalyst 3850 is the first stackable access switching platform that enables wired plus wireless services on a single Cisco IOS XE Software-based platform. With this, Cisco has pioneered a host of rich capabilities such as high availability based on stateful switchover (SSO) on stacking, granular QoS, security, and Flexible Netflow (FNF) across wired and wireless in a seamless fashion. Also, the wired plus wireless features are bundled into a single Cisco IOS Software image, which reduces the number of software images that users have to qualify/certify before enabling them in their network. The single console port for command-line interface (CLI) management reduces the number of touch points to manage for wired plus wireless services, thereby reducing network complexity, simplifying network operations, and lowering the TCO to manage the infrastructure.

Converged wired plus wireless not only improves wireless bandwidth across the network but also the scale of wireless deployment. Each 48-port Cisco Catalyst 3850 provides 40 Gbps of wireless throughput (20 Gbps on the 24-port model). This wireless capacity increases with the number of members in the stack. This makes sure that the network can scale with current wireless bandwidth requirements, as dictated by IEEE 802.11n-based access points and with future wireless standards such as IEEE 802.11ac. Additionally, the Cisco Catalyst 3850 distributes the wireless controller functions to achieve better scalability. Each Cisco Catalyst 3850 switch/stack can operate as the wireless controller in two modes:

- **Mobility agent (MA):** This is the default mode in which the Cisco Catalyst 3850 switch ships. In this mode the switch is capable of terminating the CAPWAP tunnels from the access points and providing wireless connectivity to wireless clients. Maintaining wireless client databases and configuring and enforcing security and QoS policies for wireless clients and access points can be enforced in this mode. No additional license on top of IP Base is required to operate in the mobility agent mode.
- **Mobility controller (MC):** In this mode, the Cisco Catalyst 3850 switch can perform all the mobility agent tasks in addition to mobility coordination, radio resource management (RRM), and Cisco CleanAir[®] coordination within a mobility subdomain. The mobility controller mode can be enabled on the switch CLI. IP Base license level is required when the Cisco Catalyst 3850 switch is acting as the mobility controller. A centrally located Cisco 5508 Wireless LAN Controller (WLC 5508), Cisco Wireless Services Module 2 (WiSM2) (when running AireOS Version 7.3), and Wireless LAN Controller 5760 can also perform this role for larger deployments.

With mobility agents located in the wiring closets providing 40 Gbps of wireless per switch ($n \times 40$ Gbps for a stack of n switches) and mobility controllers managing some of the central wireless functions, the converged access-based wireless deployment provides best-in-class scalability for wireless and significantly improved wireless throughput.

Figure 1. Mobility Controller (MC) and Mobility Agent (MA)

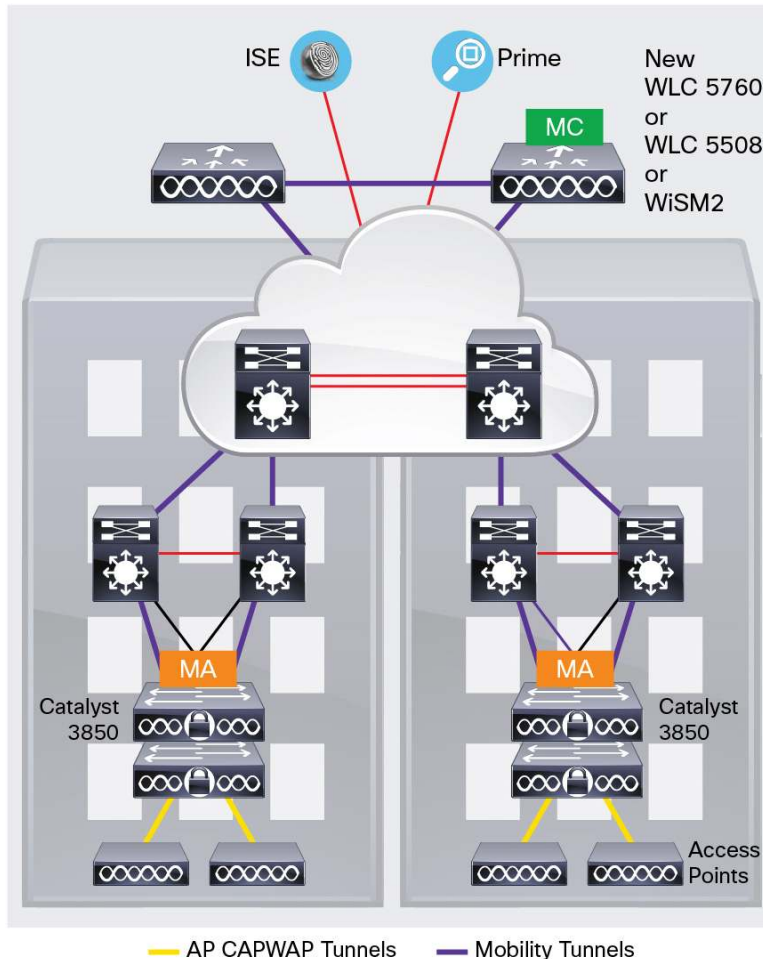

Distributed Intelligent Services

Flexible NetFlow (FNF)

Full visibility into the wired plus wireless traffic is achieved because of the access point Control and Provisioning of Wireless Access Points (CAPWAP) tunnel termination on the switch. This helps identify users and user traffic flows in order to identify potential attackers and take corrective action at the access layer before the attack penetrates further into the network. This is achieved using FNF, which monitors every single flow entering and exiting the switch stack for wired and wireless users. It also helps identify the top wired/wireless talkers and enforce appropriate bandwidth provisioning policies.

QoS

The 3850 switch has advanced wired plus wireless QoS capabilities. It uses the Cisco modular QoS command line interface (MQC). The switch manages wireless bandwidth using unprecedented hierarchical bandwidth management starting at the per-access-point level and drilling further down to per-radio, per-service set identification (SSID), and per-user levels. This helps manage and prioritize available bandwidth between various radios and various SSIDs (enterprise, guest, and so on) within each radio on a percentage basis.

The switch is also capable of automatically allocating equal bandwidth among the connected users within a given SSID. This makes sure that all users within a given SSID get a fair share of the available bandwidth while being connected to the network. The UADP ASIC enables the hierarchical bandwidth management and fair sharing of bandwidth, thereby providing hardware-based QoS for optimized performance at line-rate traffic.

In addition to these capabilities, the switch is able to do class of service (CoS) or differentiated services code point (DSCP) based queuing, policing, shaping, and marking of wired plus wireless traffic. This enables users to create common policies that can be used across wired plus wireless traffic. The 3850 also supports downloadable policy names from the Cisco Identity Services Engine (ISE) when a user successfully authenticates to the network using the ISE.

Security

The Cisco Catalyst 3850 provides a rich set of security features for wired plus wireless users. Features such as IEEE 802.1x, Dynamic Host Configuration Protocol (DHCP) snooping, IP Source Guard and control plane protection, wireless intrusion prevention systems (WIPs), and so on enable protection against unauthorized users and attackers. With a variety of wired plus wireless users connecting to the network, the switch supports session-aware networking, in which each device connected to the network is identified as one session, and unique access control lists (ACLs) and/or QoS policies can be defined and applied using the ISE for each of these sessions, providing better control on the devices connecting to the network.

Resiliency

Cisco StackWise-480 Technology

Cisco StackWise-480 technology is built on the highly successful industry-leading StackWise® technology, which is a premium stacking architecture. StackWise-480 has a stack bandwidth of 480 Gbps. StackWise-480 uses Cisco IOS Software SSO for providing resiliency within the stack. The stack behaves as a single switching unit that is managed by an “active” switch elected by the member switches. The active switch automatically elects a standby switch within the stack. The active switch creates and updates all the switching/routing/wireless information and constantly synchronizes that information with the standby switch. If the active switch fails, the standby switch assumes the role of the active switch and continues to keep the stack operational. Access points continue to remain connected during an active-to-standby switchover. A working stack can accept new members or delete old ones without service interruption. StackWise-480 creates a highly resilient single unified system of up to four switches, providing simplified management using a single IP address, single Telnet session, single CLI, auto-version checking, auto-upgrading, auto-configuration, and more. StackWise-480 also enables local switching in Cisco Catalyst 3850 Series Switches.

Cisco StackPower Technology

The Cisco Catalyst 3850 Series uses the Cisco StackPower technology present on the Cisco Catalyst 3850 Series. StackPower is an innovative power interconnect system that allows the power supplies in a stack to be shared as a common resource among all the switches. Cisco StackPower unifies the individual power supplies installed in the switches and creates a pool of power, directing that power where it is needed. Up to four switches can be configured in a StackPower stack with the special connector at the back of the switch using the StackPower cable, which is different than the StackWise-480 cables. (See Figure 4.)

Figure 2. StackWise-480 and StackPower Connectors



StackPower can be deployed in either power-sharing mode or redundancy mode. In power-sharing mode, the power of all the power supplies in the stack is aggregated and distributed among the switches in the stack. In redundant mode, when the total power budget of the stack is calculated, the wattage of the largest power supply is not included. That power is held in reserve and used to maintain power to switches and attached devices when one power supply fails, enabling the network to operate without interruption. Following the failure of one power supply, the StackPower mode becomes power sharing.

StackPower allows customers to simply add one extra power supply in any switch of the stack and either provide power redundancy for any of the stack members or simply add more power to the shared pool. StackPower eliminates the need for an external redundant power system or installation of dual power supplies in all the stack members. StackPower is available in LAN Base license level (or higher). For LAN Base, cables need to be purchased separately.

Foundation for Open Network Environment

The heart of the Cisco Catalyst 3850 is the UADP ASIC with programmability for future features and intelligence with investment protection. The new ASIC provides the foundation for converged APIs across wired and wireless, Cisco Open Network Environment, software-defined networking (SDN) readiness and OnePK SDK through software updates over the product lifetime.

Switch Configurations

All switches ship with one of the four power supplies (350W or 715W AC or 1100W AC or 440W DC). Figure 1 shows the Cisco Catalyst 3850 Series Switches (front and back).

Figure 3. Cisco Catalyst 3850 Series Switches



Table 1 shows the Cisco Catalyst 3850 Series configurations.

Table 1. Cisco Catalyst 3850 Series Configurations

Models	Total 10/100/1000 Ethernet Ports	Default AC Power Supply	Available PoE Power
WS-C3850-24T	24	350W	-
WS-C3850-48T	48		
WS-C3850-24P	24 PoE+	715W	435W
WS-C3850-48P	48 PoE+		
WS-C3850-48F	48 PoE+	1100W	800W
WS-C3850-24U	24 UPOE	1100WAC	800W
WS-C3850-48U	48 UPOE	1100WAC	800W

Licensing for Cisco Catalyst 3850 Series Switches

The three feature sets available with all Cisco Catalyst 3850 Series Switches are:

- LAN Base: Enterprise access layer 2 switching features
- IP Base: Enterprise access layer 3 switching features
- IP Services: Advanced enterprise layer 3 switching (IPv4 and IPv6) features

The LAN Base feature set offers enhanced intelligent services that include comprehensive Layer 2 features, with up to 256 VLANs. The IP Base feature set provides entry-level enterprise services in addition to all LAN Base features, with 1K VLANs. IP Base also includes the support for wireless controller functionality, routed access, Smart Operations, and Flexible Netflow. The IP Services feature set provides full enterprise services that include advanced Layer 3 features such as Enhanced Interior Gateway Routing Protocol (EIGRP), Open Shortest Path First (OSPF), Border Gateway Protocol (BGP), Protocol Independent Multicast (PIM), and IPv6 routing such as OSPFv3 and EIGRPv6. All software feature sets support advanced security and Modular Quality of Service (MQC)-based QoS.

The Cisco Catalyst 3850 Series Switches with LAN Base feature set can only stack with other Cisco Catalyst 3850 Series LAN Base switches. The same applies to IP Base and IP Services as well. A mixed stack of LAN Base switches with IP Base or IP Services is not supported.

Customers can transparently upgrade the software feature set in the Cisco Catalyst 3850 Series Switches through the Cisco IOS® Software command line interface using the Right to Use (RTU)-based software upgrade process.

AP License for Cisco Catalyst 3850

There is no license required for a Cisco Catalyst 3850 to operate as a distributed termination point for Access Points (Mobility Agent mode). The same switch can also operate in the full controller Mobility Controller (MC) mode by adding an AP license for up to 50 Access Points. Other devices that can act as an MC are the new Cisco Wireless Controller 5760, Cisco Wireless Controller 5508 and Cisco Wireless Services Module 2 (WiSM2) wireless controllers. AP licenses can be transferred between two 3850 switches or between 3850 and 5760 controller.

Software Policy for Cisco Catalyst 3850 Series Switches

Customers with Cisco Catalyst LAN Base and IP Base software feature sets will be provided with maintenance updates and bug fixes designed to maintain the compliance of the software with published specifications, release notes, and industry standards compliance as long as the original end user continues to own or use the product or up to one year from the end-of-sale date for this product, whichever occurs earlier. Customers with licenses for our IP Services software images require a service support contract such as Cisco SMARTnet® Service to download updates. This policy supersedes any previous warranty or software statement and is subject to change without notice.

Cisco Enhanced Limited Lifetime Hardware Warranty (E-LLW)

The Cisco Catalyst 3850 Series Switches come with an E-LLW that includes NBD delivery of replacement hardware where available and 90 days of 8x5 Cisco TAC support.

Your formal warranty statement, including the warranty applicable to Cisco software, appears in the Cisco information packet that accompanies your Cisco product. We encourage you to review carefully the warranty statement shipped with your specific product before use.

Cisco reserves the right to refund the purchase price as its exclusive warranty remedy.

For further information on warranty terms, visit <http://www.cisco.com/go/warranty>. Table 2 provides information about the E-LLW.

Table 2. E-LLW Details

	Cisco E-LLW
Device covered	Applies to Cisco Catalyst 3850 Series Switches.
Warranty duration	As long as the original customer owns the product.
EoL policy	In the event of discontinuance of product manufacture, Cisco warranty support is limited to 5 years from the announcement of discontinuance.
Hardware replacement	Cisco or its service center will use commercially reasonable efforts to ship a replacement for NBD delivery, where available. Otherwise, a replacement will be shipped within 10 working days after receipt of the RMA request. Actual delivery times might vary depending on customer location.
Effective date	Hardware warranty commences from the date of shipment to customer (and in case of resale by a Cisco reseller, not more than 90 days after original shipment by Cisco).
TAC support	Cisco will provide during business hours, 8 hours per day, 5 days per week basic configuration, diagnosis, and troubleshooting of device-level problems for up to a 90-day period from the date of shipment of the originally purchased Cisco Catalyst 3850 product. This support does not include solution or network-level support beyond the specific device under consideration.
Cisco.com access	Warranty allows guest access only to Cisco.com.

Availability

The switch will be available and orderable in January 2013.

Ordering Information

Table 3 lists ordering information for the Cisco Catalyst 3850 Series. To place an order, visit the Cisco Ordering homepage at http://www.cisco.com/en/US/ordering/or13/or8/order_customer_help_how_to_order_listing.html.

Table 3. Cisco Catalyst 3850 Series Ordering Information

Product Number	Product Description
Cisco Catalyst 3850 Series	
WS-C3850-24T-L	Stackable 24 10/100/1000 Ethernet ports, with 350W AC power supply 1 RU, LAN Base feature set (StackPower cables need to be purchased separately)
WS-C3850-48T-L	Stackable 48 10/100/1000 Ethernet ports, with 350W AC power supply 1 RU, LAN Base feature set (StackPower cables need to be purchased separately)
WS-C3850-24P-L	Stackable 24 10/100/1000 Ethernet PoE+ ports, with 715W AC power supply 1 RU, LAN Base feature set (StackPower cables need to be purchased separately)
WS-C3850-24U-L	Stackable 24 10/100/1000 Ethernet UPOE ports, with 1100WAC power supply 1 RU, LAN Base feature set (StackPower cables need to be purchased separately)
WS-C3850-48P-L	Stackable 48 10/100/1000 Ethernet PoE+ ports, with 715W AC power supply 1 RU, LAN Base feature set (StackPower cables need to be purchased separately)
WS-C3850-48F-L	Stackable 48 10/100/1000 Ethernet PoE+ ports, with 1100W AC power supply 1 RU, LAN Base feature set (StackPower cables need to be purchased separately)
WS-C3850-48U-L	Stackable 48 10/100/1000 Ethernet UPOE ports, with 1100WAC power supply 1 RU, LAN Base feature set (StackPower cables need to be purchased separately)
WS-C3850-24T-S	Stackable 24 10/100/1000 Ethernet ports, with 350W AC power supply 1 RU, IP Base feature set
WS-C3850-48T-S	Stackable 48 10/100/1000 Ethernet ports, with 350W AC power supply 1 RU, IP Base feature set
WS-C3850-24P-S	Stackable 24 10/100/1000 Ethernet PoE+ ports, with 715W AC Power Supply 1 RU, IP Base feature set
WS-C3850-24U-S	Stackable 24 10/100/1000 Ethernet UPOE ports, with 1100WAC power supply 1 RU, IP Base feature set
WS-C3850-48P-S	Stackable 48 10/100/1000 Ethernet PoE+ ports, with 715W AC Power Supply 1 RU, IP Base feature set
WS-C3850-48F-S	Stackable 48 10/100/1000 Ethernet PoE+ ports, with 1100W AC power supply 1 RU, IP Base feature set
WS-C3850-48U-S	Stackable 48 10/100/1000 Ethernet UPOE ports, with 1100WAC power supply 1 RU, IP Base feature set
WS-C3850-24T-E	Stackable 24 10/100/1000 Ethernet ports, with 350W AC power supply 1 RU, IP Services feature set
WS-C3850-48T-E	Stackable 48 10/100/1000 Ethernet ports, with 350W AC power supply 1 RU, IP Services feature set
WS-C3850-24P-E	Stackable 24 10/100/1000 Ethernet PoE+ ports, with 715W AC Power Supply 1 RU, IP Services feature set
WS-C3850-24U-E	Stackable 24 10/100/1000 Ethernet UPOE ports, with 1100WAC power supply 1 RU, IP Services feature set
WS-C3850-48P-E	Stackable 48 10/100/1000 Ethernet PoE+ ports, with 715W AC Power Supply 1 RU, IP Services feature set
WS-C3850-48F-E	Stackable 48 10/100/1000 Ethernet PoE+ ports, with 1100W AC Power Supply 1 RU, IP Services feature set
WS-C3850-48U-E	Stackable 48 10/100/1000 Ethernet UPOE ports, with 1100WAC power supply 1 RU, IP Services feature set

Product Number	Product Description
Cisco Catalyst 3850 Bundles	
WS-C3850-24PW-S	Cisco Catalyst 3850 24-Port PoE IP Base with 5 AP license
WS-C3850-48PW-S	Cisco Catalyst 3850 48-Port PoE IP Base with 5 AP license
Network Modules for the Cisco Catalyst 3850 Series	
C3850-NM-4-1G=	4 x 1GE Network Module spare
C3850-NM-2-10G=	4 x 1GE/2 x 10GE Network Module spare
C3850-NM-BLANK=	Network module blank spare
C3850-NM-4-10G=	4 x 1GE/4 x 10GE Network Module spare
Software Licenses	
C3850-24-L-S	Cisco Catalyst 3850 24 port Switch LAN Base to IP Base Paper License
C3850-48-L-S	Cisco Catalyst 3850 48 port Switch LAN Base to IP Base Paper License
C3850-24-L-E	Cisco Catalyst 3850 24 port LAN Base to IP Services Paper License
C3850-48-L-E	Cisco Catalyst 3850 48 port LAN Base to IP Services Paper License
C3850-24-S-E	Cisco Catalyst 3850 24 port IP Base to IP Services Paper License
C3850-48-S-E	Cisco Catalyst 3850 48 port IP Base to IP Services Paper License
L-C3850-24-L-S	Cisco Catalyst 3850 24 port LAN Base to IP Base E-License
L-C3850-48-L-S	Cisco Catalyst 3850 48 port LAN Base to IP Base E-License
L-C3850-24-L-E	Cisco Catalyst 3850 24 port LAN Base to IP Services E-License
L-C3850-48-L-E	Cisco Catalyst 3850 48 port LAN Base to IP Services E-License
L-C3850-24-S-E	Cisco Catalyst 3850 24 port IP Base to IP Services E-License
L-C3850-48-S-E	Cisco Catalyst 3850 48 port IP Base to IP Services E-License
AP Licenses	
L-LIC-CT3850-UPG	Primary upgrade license SKU for Cisco 3850 Wireless Controller (e-delivery)
L-LIC-CTIOS-1A	1 AP Adder License for the IOS based Wireless Controller (e-delivery)
LIC-CT3850-UPG	Primary upgrade license SKU for Cisco 3850 Wireless Controller (paper license)
LIC-CTIOS-1A	1 AP Adder License for the IOS based Wireless Controller (paper license)
Power Supplies and Fan for the Cisco Catalyst 3850 Series	
PWR-C1-350WAC=	350W AC power supply spare
PWR-C1-715WAC=	715W AC power supply spare
PWR-C1-1100WAC=	1100W AC power supply spare
PWR-C1-440WDC=	440W DC power supply spare
PWR-C1-BLANK=	Power supply blank spare
C3850-FAN-T1=	Fan module spare
Stackwise-480 and StackPower Cables for the Cisco Catalyst 3850 Series	
STACK-T1-50CM=	Cisco Stackwise-480 50 cm stacking cable spare
STACK-T1-1M=	Cisco Stackwise-480 1 m stacking cable spare
STACK-T1-3M=	Cisco Stackwise-480 3 m stacking cable spare
CAB-SPWR-30CM=	Cisco Catalyst 3850 StackPower cable 30 cm spare
CAB-SPWR-150CM=	Cisco Catalyst 3850 StackPower cable 150 cm spare
Spare Power Cords for the Cisco Catalyst 3850 Series	
CAB-TA-NA=	AC Power Cord for Cisco Catalyst 3850 (North America)
CAB-TA-AP=	AC Power Cord for Cisco Catalyst 3850 (Australia)
CAB-TA-AR=	AC Power Cord for Cisco Catalyst 3850 (Argentina)
CAB-TA-SW=	AC Power Cord for Cisco Catalyst 3850 (Switzerland)

Product Number	Product Description
CAB-TA-UK=	AC Power Cord for Cisco Catalyst 3850 (United Kingdom)
CAB-TA-JP=	AC Power Cord for Cisco Catalyst 3850 (Japan)
CAB-TA-250VAC-JP=	Japan 250V AC Power Cord for Cisco Catalyst 3850 (Japan)
CAB-TA-EU=	AC Power Cord for Cisco Catalyst 3850 (Europe)
CAB-TA-IT=	AC Power Cord for Cisco Catalyst 3850 (Italy)
CAB-TA-IN=	AC Power Cord for Cisco Catalyst 3850 (India)
CAB-TA-CN=	AC Power Cord for Cisco Catalyst 3850 (China)
CAB-TA-DN=	AC Power Cord for Cisco Catalyst 3850 (Denmark)
CAB-TA-IS=	AC Power Cord for Cisco Catalyst 3850 (Israel)
CAB-C15-CBN	Cabinet Jumper Power Cord, 250 VAC 13A, C14-C15 Connectors
Spare Accessory and Rack Mount Kits for the Cisco Catalyst 3850 Series	
C3850-ACC-KIT=	Accessory kit for Cisco Catalyst 3850 Series
C3850-RAC-KIT=	Rack mount kit for Cisco Catalyst 3850 Series
C3850-4PT-KIT=	Extension rails and brackets for four-point mounting for Cisco Catalyst 3850 Series

Optics Compatibility Information

The Cisco Catalyst 3850 Series support a wide range of optics. Since the list of supported optics is updated on a regular basis, consult the tables available here for the latest SFP compatibility information:

http://www.cisco.com/en/US/products/hw/modules/ps5455/products_device_support_tables_list.html.

How to buy

To view buying options and speak with a Cisco sales representative, visit www.cisco.com/c/en/us/buy.



Americas Headquarters
Cisco Systems, Inc.
San Jose, CA

Asia Pacific Headquarters
Cisco Systems (USA) Pte. Ltd.
Singapore

Europe Headquarters
Cisco Systems International BV Amsterdam,
The Netherlands

Cisco has more than 200 offices worldwide. Addresses, phone numbers, and fax numbers are listed on the Cisco Website at www.cisco.com/go/offices.

Cisco and the Cisco logo are trademarks or registered trademarks of Cisco and/or its affiliates in the U.S. and other countries. To view a list of Cisco trademarks, go to this URL: www.cisco.com/go/trademarks. Third party trademarks mentioned are the property of their respective owners. The use of the word partner does not imply a partnership relationship between Cisco and any other company. (1110R)