

Simplify Your Network Edge

Reduce cost and complexity with Cisco UCS E-Series Servers

What you will learn

In this document you will learn the benefits of remote- and branch-office computing using Cisco Unified Computing System™ (Cisco UCS®) E-Series Servers. With these servers you can easily extend your digital transformation to the very edge of the network where your business directly meets customers, employees, and Internet of Things (IoT) devices. This will enable you to localize relevant computing and data to deliver faster service and be more competitive. Easy to deploy and maintain, this solution will cut costs by hosting your applications locally.

Contents

Cost of computing at branch or remote offices	3
A better solution: Cisco UCS E-Series Servers.....	3
How Cisco UCS E-Series servers fit in the market	4
Unique in the market.....	4
Cisco UCS E-Series Servers and Cisco 4000 Series ISRs	4
Server virtualization.....	5
System management.....	6
How customers deploy these servers	7
Solutions	9
Support	9
Benefit your remote and branch offices	10

Cost of computing at branch or remote offices

Whether you are running a chain of retail stores, bank branches, classrooms, or health clinics, or are collecting IoT data at a remote site, your digital transformation needs to reach these locations. Business digitization is evolving from siloed administrative islands (in the form of headquarters, branches, data centers, and public and private cloud services) to an integrated ecosystem in which decisions on data flow and computing are paramount to the success and effectiveness of business operations. Traditional roles of the data center are evolving and pushing computing to the network edge for security and efficiency. However, not all remote or branch offices have the space, power, or cooling to support a rack of servers along with the associated switches and storage. And reliance on 100 percent uptime for networking back to your data center can lead to business disruption.

The most tangible example is a slow-moving retail store checkout line. You've heard "I'm sorry, but the computers are really slow today." This comment has a back story of reduced application performance due to poor network performance. In addition, the traditional model for supporting remote locations has led to costly support outsourcing. These costs and complications of additional support from separate vendors in different locations can eat away at profits. The less equipment there is to install, configure, cable, and maintain, the better it is for your bottom line.

A better solution: Cisco UCS E-Series Servers

[Cisco UCS E-Series Servers](#) solve these problems by bringing data center-class blade servers to your remote and branch offices. These powerful, small form-factor, x86-architecture, 64-bit blade servers reside in Cisco® branch-office routers—the [Cisco® 4000 Series Integrated Services Routers \(ISRs\)](#). E-Series blade servers are virtualization-ready and host essential infrastructure services and business-critical applications while allowing you to maintain a lean remote- or branch-office environment (Figure 1).

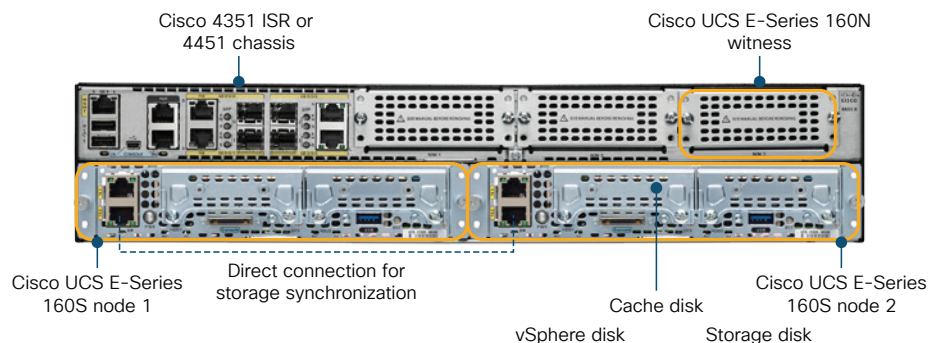

Figure 1 Cisco UCS E-Series 160S nodes in a single-wide Cisco 4000 Series ISR

How Cisco UCS E-Series servers fit in the market

An ISR combined with E-Series servers is an excellent way to simplify your branch, retail, and remote-office deployments down to a single device per office. It helps you bring computing power close to your users for excellent responsiveness without the need to have WAN connectivity all of the time. It works well for a range of remote workloads such as network services, IT services, and even virtual desktops and IoT data processing. Even though these servers are located outside of the data center, they have centralized policy-based management that can be orchestrated from your data center. This can greatly reduce costs.

Unique in the market



Cisco UCS E-Series Servers are unique in the market. They fit into equipment you need (and may already have) to deploy a remote or branch office—a router, specifically a Cisco 4000 Series ISR. This symbiotic architecture, in which the power and connectivity are shared, greatly reduces your TCO through energy and space savings, less-expensive single-socket Intel® Xeon® E3 family processors, wire-free setup, simplified memory and storage options, and a single point of contact for support. The solution's software licensing options and remote policy-based management capabilities allow you to accelerate your responsiveness and reduce the need for local IT staff.

Cisco UCS E-Series Servers and Cisco 4000 Series ISRs

The Cisco 4000 Series ISRs combine networking, computing, and storage in a single small package. The 4000 Series provides network automation and software-defined WAN (SD-WAN), branch threat defense with security and firewall capabilities across LAN and WAN, and network services such as WAN and application optimization, intelligent caching, and unified communications. The 4000 Series is also virtualization-ready.

Cisco UCS E-Series Servers can be used as hyperconverged infrastructure with VMware vSAN software, which can virtualize servers and storage to host essential services and business-critical applications, enabling you to maintain a lean branch-office environment. These blade servers fit into ISR chassis slots. Small servers can fit into network interface module (NIM) slots, single-wide servers can occupy one service module slot, and double-wide servers can occupy two service module slots (Table 1).

Table 1 Comparison of Cisco UCS E-Series blade servers

	UCS-E160S-M3/K9	UCS-E180D-M3/K9	UCS E-1120
			
Processor	Intel Xeon D-1528 (6 x 1.9 GHz)	Intel Xeon D-1548 (8 x 2.0 GHz)	Intel Xeon D-1557 (12 x 1.5 GHz)
Cores/vCPU	6/12	8/16	12/24
Memory	16 to 64 GB DDR4	16 to 128 GB DDR4	16 to 128 GB DDR4
Storage	Up to 8 TB (2 HDD bays) SATA, SAS, SED, SSD	Up to 16 TB (4 HDD bays) SATA, SAS, SED, SSD	Up to 16 TB (4 HDD bays) SATA, SAS, SED, SSD
RAID	RAID 0, 1	RAID 0, 1, 5, 10	RAID 0, 1
Network ports	Internal: 2 x 1 GE ports External: 2 x 10 GE ports	Internal: 2 x 1 GE ports External: 2 x 10 GE ports	Internal: 2 x 1 GE ports External: 2 x 10 GE ports
ISR model compatability	4331, 4351, 4451	4351, 4451	4351, 4451
Size	Single-wide (1 service module slot)	Double-wide (2 service module slots)	Double-wide (2 service module slots)

Server virtualization

With Cisco UCS E-Series Servers, you can choose your hypervisor and operating system. Because these servers are VMware vSAN certified, VMware ESX Server, VMware vCenter, and vSAN can be preinstalled with support for either hybrid or all-flash storage.

When supporting vSAN in your ISR, you need a minimum of two vSAN ReadyNodes plus a “witness” server that serves as a tie breaker in failover decisions. When fewer than three nodes are populated in the ISR (two single-wide slots and one NIM slot), a vSAN witness server will have to reside in the data center. This configuration requires WAN connectivity for effective failover.

System management

With the Cisco UCS E-Series Servers you have a choice of policy-based management interfaces. All Cisco UCS servers can be managed with the embedded Cisco Integrated Management Controller (IMC). The Cisco IMC enables system management in the data center and across distributed branch-office locations. It supports multiple management interfaces, including a web user interface, a command-line interface (CLI), and an API. It enables complete configuration and monitoring of the system and system resources. It supports out-of-band, nondisruptive upgrades of the system BIOS and Cisco IMC firmware. It supports industry-standard management protocols, including Redfish v1.01, Simple Network Management Protocol version 3 (SNMPv3), and Intelligent Platform Management Interface version 2.0 (IPMIv2.0). Its API has an easily programmable interface that enables higher-level management platforms and CLIs to efficiently and effectively interact with the system, including the following:

- **Microsoft Windows PowerShell support through Cisco UCS PowerTool** is a Microsoft PowerShell module that helps automate all aspects of Cisco UCS management, including server, network, storage and hypervisor management.
- **Cisco IMC Supervisor** enables centralized management for standalone Cisco UCS C-Series Rack Servers, E-Series Servers, and S-Series Storage Servers located across one or more sites. It provides insight into the platforms being managed, including information about system inventory and faults reported on one or more systems. Managed systems can be assigned to user-defined groups to help keep platforms organized based on criteria important to the administration team. Across and within these groups, each system can be given one or more tags to assign searchable metadata to the server. Administrators can perform basic management tasks on individual systems such as power on, power off, and vKVM launch. Tasks for multiple platforms, including noninteractive firmware updates and diagnostic tools, are also supported.
- **Cisco Digital Network Architecture (Cisco DNA™)** takes a software-delivered approach to automating and assuring services across your campus, WAN, and branch networks. Based on an open and extensible platform, Cisco DNA allows you to build value on the network, so you can streamline operations and facilitate IT and business innovation. Cisco DNA Center™ is a single dashboard that can be used to manage and automate your network, including Cisco ISRs and E-Series servers. It allows quick scaling of deployments with intuitive workflows and reusable templates that enable the configuration and provisioning of thousands of network devices across your enterprise in minutes, not hours. Apply policy to users and applications instead of to your network devices. Its automation capabilities reduce manual operations and the costs associated with human errors. This results in more uptime and improved security.

DNA Center assesses the network and uses context to turn data into intelligence, making sure that changes in the network device policies achieve your intent. DNA Center Assurance provides actionable insights that simplify network operations and reduce the time to issue resolution.

Depending on how you use your Cisco UCS E-Series Servers, you get to choose who manages your branch and remote-office servers, and with what interface.

How customers deploy these servers

Cisco UCS E-Series Servers are deployed in many contexts to provide infrastructure services and to run industry-based applications including the following:

- **IoT:** Cisco UCS E-Series Servers are being used at remote sites to provide data collection and data filtering, cleaning, and compression before the useful data is uploaded to the central data center.
- **Video surveillance:** Cisco Video Surveillance Manager provides a comprehensive, policy-based system for physical security and video surveillance to increase worker productivity across many cameras. This can help enable your network and security teams to collaborate effectively to combine video, advanced analytics, and IoT sensor integration. Keeping data locally on Cisco UCS E-Series Servers unless needed saves on WAN bandwidth.
- **Virtual desktops:** If you need a branch or remote [office-in-a-box](#), these servers can support up to 20 knowledge workers running on virtual desktops.
- **Healthcare:** Simplify your clinic while also supporting digital transformation. With the Cisco UCS E-Series Servers, you can store digital images and patient data to gain fast access to this data while with patients. You can run your billing and appointment office applications on virtual desktops. The servers can also capture, store, and manage your video surveillance.
- **Retail:** Save your valuable floor space for merchandise and customers with this solution. You can run your point-of-sale (POS), credit card payment, content delivery and training videos, file and print services, domain controllers, and other key services locally for faster customer service and employee training. There is no need for IT technicians to travel to stores to add applications or make configuration changes. They can be configured centrally and with better compliance because of the consistency that our configuration tools impose.
- **Restaurants:** Accelerate ordering, easily update in-shop and catering menus, create an ordering kiosk for take-out orders, run your point-of-sale applications, track supplies, run back-office applications and virtual desktops, you name it. These servers take little space and can provide powerful services.

“The POS application is now a virtual machine on the blade server. Inserting a Cisco UCS E-Series Server in the router chassis doesn’t require extra rack space. And when we refresh store servers every two to three years, it’s as simple as sliding one blade out and inserting another.”

Suzan Pickett

Manager of systems engineering
Columbia Sportswear

- **Financial:** Speed up your bank’s teller lines with local data and data processing. Virtual desktops accelerate access times, protect important data, and reduce costs at your branches. Run your custom banking and teller applications as well as print and file services off of these servers. Host trading applications locally to reduce latency and provide a competitive edge.
- **Digital trust services:** Digital transformation is changing our lives for the better, but it is also creating new risks. How do you keep the trust of your customers when interacting digitally? How do you secure payments or money transfers? How do you effectively remove spam and junk emails? Where and when can your digital data be used? Digital trust touches every aspect of digital interaction. Localized digital trust services, such as identity management, authentication, and biometric devices and applications, can all run on these servers.
- **Cloud services with data localization:** Cloud services are great for running applications. The problem comes with moving data around the WAN and waiting for that data. Having local servers that can act as storage servers can significantly reduce wait times and increase user satisfaction.
- **Back-office applications:** Move both your applications (email, communications, inventory control, accounting, human resources, quality control) and data closer with these cost- and space-effective servers.
- **Kiosks:** Need to loop through the latest houses for sale? Want to speed up take-out orders? Need to provide location maps in a large conference center or hotel? Need to post an agenda of events that day? All these can be accomplished in a kiosk with Cisco UCS E-Series Servers. And if you need to update the content, just download a new file.
- **Network functions virtualization:** Cisco Enterprise Network Functions Virtualization (NFV) converts your critical network functions into software, making it possible to deploy services in minutes. You can activate those network functions on a Cisco UCS E-Series Server module with the Cisco 4000 Series ISRs. We’ve made it simple and easy to design, provision, and manage services across all your branches. Create virtual network appliances or virtual versions of traditional network functions.
- **General Data Protection Regulation (GDPR) compliance:** You are required to ensure data assurance, visibility, and accountability for your handling of data with the European Union’s GDPR. One way to accomplish this is to keep your data local to your branch and remote offices. Once you move the data, the problem becomes more difficult. However, with these servers, you can provide continuous, end-to-end monitoring and analysis of the traffic data, or “wire data,” flowing over the network and where the data is stored.
- **Business continuity:** With data and application services local to your branch, you won’t have to worry about data center outages, or

outages at other locations, having an effect on your branch business. In addition, to combat local power outages, it is easy to purchase a small backup power supply to keep your data and applications available.

Solutions

Cisco has aligned with other vendors to create solutions using the Cisco UCS E-Series Servers and the Cisco 4000 Series ISRs:

- [StorMagic Citrix VDI Cloud Connector](#): Combines Citrix desktop and application virtualization (Citrix XenDesktop and XenApp), Citrix Cloud Connector, StorMagic SvSAN software-defined storage, and Microsoft Hyper-V, all running on Cisco UCS E-Series Servers to create remote user workstations.
- [IBM Enterprise Content Delivery Network \(ECDN\)](#) enables you to relieve bottlenecks associated with delivering security-enhanced video to single or multiple corporate connections.
- [Arbor Distributed Denial of Service \(DDoS\) protection and network visibility](#) keep your services up and running.

Support

Cisco Smart Net Total Care® Service provides award-winning technical support along with an entitlement to smart capabilities. This enables you to solve problems faster, improve operational efficiency, and reduce the risk of downtime. Smart Net Total Care gives you more time to focus on business innovation while proactively supporting your infrastructure. With this service you get:

- Cisco Technical Assistance Center (TAC) expertise with 24-hour access to resolve critical issues
- Hardware replacement, when necessary, within a selected delivery time
- Web and mobile support to access model-specific content, download software, use automated tools, get alerts, access forums, and manage your TAC cases
- Software updates
- Smart capabilities that use one portal to manage your Cisco inventory, view lifecycle details, check contract status, assess alert information, and run reports
- Support innovations using AI and big data analytical capabilities
- Access to all Cisco Validated Designs and Reference Architectures to make deployments consistent and quick

You gain all of this with no additional up-front cost.

Learn more

- [Cisco UCS E-Series Servers](#)

Benefit your remote and branch offices

Cisco UCS E-Series Servers, combined with Cisco 4000 Series ISRs, simplify your branch, retail, and remote-office deployments down to a single box per office. They allow you to bring computing power and data close to your users for excellent responsiveness without the need to have WAN connectivity all of the time. This solution works well for a range of remote workloads such as network services, IT services, virtual desktops, and IoT data processing. The centralized policy-based management that can be managed from your data center can greatly reduce costs. Cisco Smart Net Total Care support keeps your servers up and running. With Cisco UCS E-Series Servers and Cisco 4000 Series ISRs, you have a complete branch-in-a-box that supports your edge computing and networking needs while also providing the physical requirements of telephony, Internet, and wireless access. Enable your digital transformation all the way out to the edge of your computing needs at your remote and branch offices.