

Cisco UCS B460 M4 Blade Server

Product Overview

The Cisco UCS[®] B460 M4 Blade Server uses the power of the Intel[®] Xeon[®] processor E7 v2, E7 v3 and E7 v4 product family to add new levels of performance and capabilities to the innovative Cisco Unified Computing System[™] (Cisco UCS). Cisco UCS (Figure 1) combines Cisco UCS B-Series Blade Servers and C-Series Rack Servers with networking and storage access resources into a single converged system that greatly simplifies server management and delivers greater cost efficiency and agility. It also offers advances in fabric-centric computing, open APIs, and application-centric management, and uses service profiles to automate all aspects of server deployment and provisioning.

The Cisco UCS B460 M4 (Figure 2) is the flagship of the Cisco UCS B-Series Blade Servers products, which address compute- and memory-intensive enterprise-critical workloads. This blade server has the computational horsepower and memory capacity to satisfy the requirements of the most demanding enterprise-critical applications such as business intelligence, large-scale databases, in-memory analytics, as well as RISC migration.

Figure 1. Overview of Cisco UCS

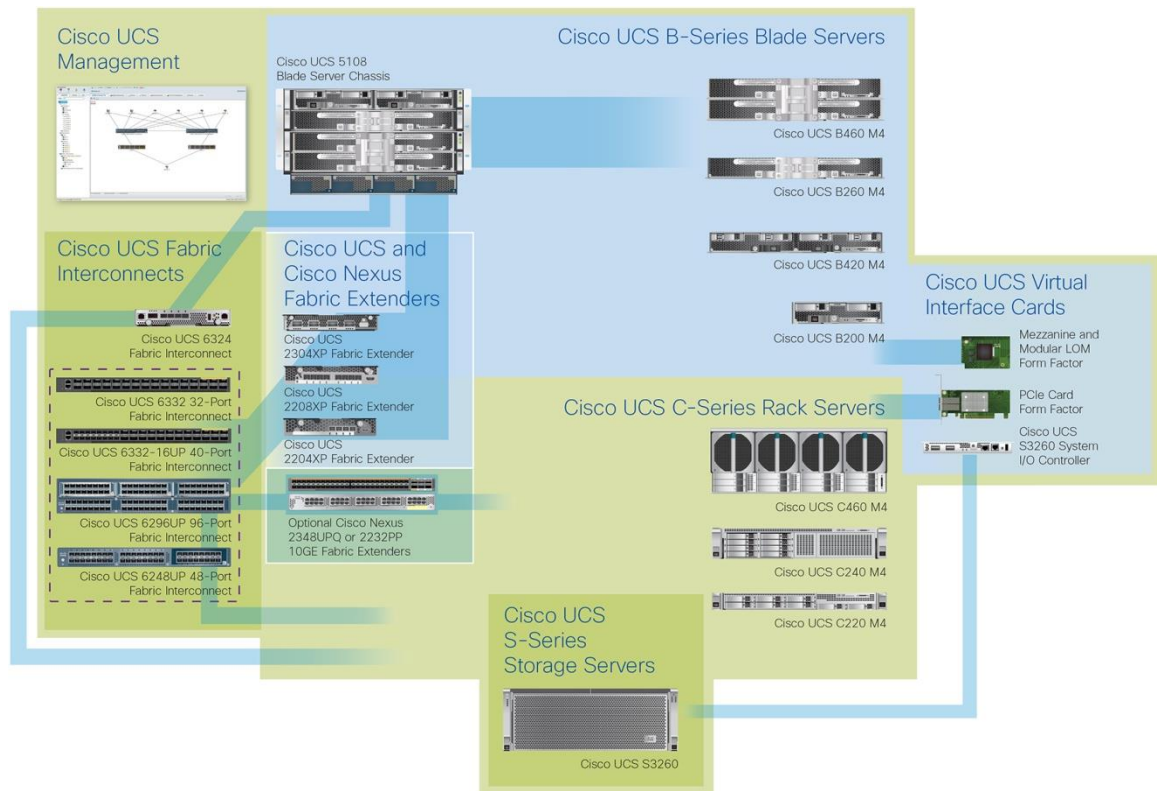

Figure 2. Cisco UCS B460 M4 Blade Server



Greater Performance and Architectural Advantages

The Cisco UCS B460 M4 harnesses the power of four Intel Xeon processor E7 v2, E7 v3, or E7 v4 product family and accelerates access to critical data. This blade server supports up to 96 processor cores, 6.0 TB of memory, 6.4 TB of internal storage, and 320 Gbps of overall Ethernet throughput.

In addition, the fabric-centric, architectural advantage of Cisco UCS means that you do not need to purchase, maintain, power, cool, and license excess switches and interface cards in each Cisco UCS blade chassis, enabling Cisco to design uncompromised expandability and versatility in its blade servers. As a result, with their leading CPU core count, frequencies, memory slots, expandability, and drive capacities, the Cisco UCS B-Series Blade Servers offer uncompromised expandability, versatility, and performance.

The Cisco UCS B460 M4 provides:

- Four Intel Xeon processor E7 v2, E7 v3, or E7 v4 product family
- 96 DDR3 or DDR4 memory DIMM slots
- Four hot-pluggable drive bays for Hard Disk Drives (HDDs) or Solid State Disks (SSDs)
- SAS controller on board with RAID 0 and 1 support
- Two modular LAN on motherboard (mLOM) slots for Cisco UCS Virtual Interface Card (VIC)
- Six PCIe mezzanine slots, with two dedicated for optional Cisco UCS VIC 1340, and four slots for Cisco UCS VIC 1380, VIC port expander, or flash cards

Cisco UCS VIC 1340 and 1380 Technology

The Cisco UCS VIC 1340 is a 2-port 40-Gbps Ethernet or Fibre Channel over Ethernet (FCoE)-capable mLOM designed exclusively for the M4 generation of the Cisco UCS B-Series Blade Servers. When used in combination with an optional port expander, the Cisco UCS VIC 1340 can be expanded to up to four 40-Gbps ports.

The Cisco UCS VIC 1380 is a dual-port 40-Gbps Ethernet or FCoE adapter that further expands Cisco UCS B460 M4 Blade Server bandwidth to 160 Gbps. The Cisco UCS VIC 1340 and 1380 enable a policy-based, stateless, agile server infrastructure that can present up to 256 PCI Express (PCIe) standards-compliant interfaces to the host, which can be dynamically configured as either network interface cards (NICs) or host bus adapters (HBAs). In addition, the Cisco UCS VIC 1340 and 1380 support Cisco® Data Center Virtual Machine Fabric Extender (VM-FEX) technology, which extends the Cisco UCS fabric interconnect ports to virtual machines, simplifying server virtualization deployment.

Powering Mission-Critical Applications

The Cisco UCS B460 M4 Blade Server continues Cisco's commitment to delivering differentiated value, fabric integration, and ease of management that is exceptional in the marketplace for mission critical applications:

- Business intelligence
- RISC migration
- Decision support
- In-memory analytics
- Large-scale databases
- Large-scale, virtualized applications
- Enterprise-critical middleware
- Large memory and consolidation workloads

Cisco UCS Servers Change the Economics of the Data Center

IT infrastructure matters now more than ever, as organizations seek to achieve the full potential of IaaS, bare-metal, virtualized servers, and cloud computing. Cisco continues to lead in data center innovation with the introduction of these new, mission-critical server building blocks for Cisco UCS that extends its exceptional simplicity, agility, and efficiency. New innovations like the Cisco UCS B460 M4 Blade Server bring greater levels of industry-leading performance and memory locality from IT infrastructure to enterprise applications. In addition, Cisco UCS is a solution beyond individual rack or blades servers that conveys enormous benefits to customers (Table 1).

Table 1. Benefits of UCS Servers

Benefit	Technology	Application Customer Benefit
Lower costs	Cisco SingleConnect technology	Fewer cables, HBAs, NICs, and switches to purchase, license, power, cool, and maintain
Greater flexibility	Cisco UCS Manager software: total hardware abstraction	<ul style="list-style-type: none">• Less configuration drift among servers• Server provisioning times that are reduced from days to minutes• Servers that are provisioned in an automated and consistent manner• Future foundation for fast, consistent server provisioning
Total openness	Open APIs	<ul style="list-style-type: none">• Unique visibility into Cisco UCS beyond Cisco UCS Manager to UCS Director and other third-party management tools

In addition, Cisco UCS provides three major innovations that lower both capital and operating expenditures for server customers: Cisco Single Connect technology, Cisco UCS Manager software, and open APIs.

- Cisco SingleConnect technology provides a dramatic fabric simplification of networking and cabling infrastructure: one easy, intelligent, and efficient way to connect rack and blade servers, physical and virtual environments, LAN and SAN, and management.
- Cisco UCS Manager helps reduce management and administration expenses, which are among the largest items in most IT budgets. The UCS Manager can manage up to 160 servers and thousands of Cisco UCS components in multiple chassis. The embedded management software and all the managed components are part of a UCS domain.

- Cisco UCS Manager supports a comprehensive, automation-friendly, open XML API that exposes 9000 points of integration. This facilitates custom development to achieve new levels of system visibility and control. The XML API for Cisco UCS Manager enables automation-friendly insertion into existing IT staff skills, tools, processes, and management tools.

In addition, Cisco continues to push the frontier of innovation in all Cisco UCS building blocks and supporting technologies. For example, new Cisco VIC options, expanded Cisco UCS fabric interconnects and additional fabric extender options expand both throughput and management simplicity for both blade and rack servers. Cisco Data Center VM-FEX technology collapses virtual and physical networking into a single infrastructure. Data center administrators can now provision, configure, manage, monitor, and diagnose virtual machine network traffic and bare-metal network traffic within a unified infrastructure.

Together these Cisco UCS architectural advantages, software advances, and continuous Cisco innovation, coupled with unique blade server and chassis design, help make Cisco UCS the first truly unified data center platform.

Features and Benefits

Table 2 summarizes the features and benefits of the Cisco UCS B460 M4 server.

Table 2. Features and Benefits

Feature	Benefit
Unified fabric	<ul style="list-style-type: none"> • Decreases total cost of ownership (TCO) by reducing the number of NICs, HBAs, switches, and cables needed • Enables the Cisco 5108 Blade Server Chassis to eliminate in-chassis HBAs, NICs, and switches and reallocates the saved power to denser, more powerful blade servers with more DIMM slots and better per-blade performance compared to alternative offerings
Cisco UCS Manager service profiles	<ul style="list-style-type: none"> • Helps reduce the number of manual steps required to deploy servers in the data center, improving server policy consistency and coherency • Allows servers and support infrastructure to be provisioned in minutes instead of days, shifting IT's focus from maintenance to strategic initiatives • Reduces configuration errors significantly as blades are added or repurposed • Enables service profile movement from blade to blade, rack server to blade, blade to rack server, or blade to blade in another chassis
Autodiscovery	<ul style="list-style-type: none"> • Requires no configuration; as with all Cisco UCS components, Cisco UCS B-Series blades and Cisco UCS C-Series racks are automatically recognized and configured by Cisco UCS Manager
Extensive monitoring	<ul style="list-style-type: none"> • Through Cisco UCS Manager, provides extensive environmental monitoring for each blade • Allows use of user thresholds to optimize environmental management of the blade
Cisco VIC adapter	<ul style="list-style-type: none"> • Cisco UCS VIC 1340 is a 2-port 40 Gigabit Ethernet, Fibre Channel over Ethernet (FCoE)-capable adapter. • When used in combination with its port expander card, the Cisco UCS VIC 1340 can be expanded to 4 ports of 40 Gigabit Ethernet support.
Mezzanine adapters	Provides choice of VICs, and PCIe flash-memory devices, providing flexibility, increased application performance, compatibility with industry standards, and network policy coherence for virtualized environments
Cisco Flexible Flash memory	<ul style="list-style-type: none"> • The server includes two internal Cisco Flexible Flash SD cards • Dual SDHC flash card sockets are provided on the front left side of the server for VMware ESXi loading functions.
Optional local storage	<ul style="list-style-type: none"> • Provides support for up to four front-accessible hot-pluggable hard disk drives (HDDs) or solid state disks (SSDs).

Feature	Benefit
Intel Xeon Processor E7 v2, E7 v3 and E7 v4 product family	<ul style="list-style-type: none"> • The processor family boosts business intelligence by rapidly processing and analyzing large amounts of data in near real-time. For more information, go to http://www.cisco.com/en/US/prod/ps10265/industry_benchmarks.html. • Up to 6 TB of memory in the Cisco UCS B460 M4 blade server allows faster access to more data, resulting in quicker answers from today's most demanding applications. Keep data local with up to 1.5 TB of memory per socket to easily manage data-demanding, transaction-intensive workloads. Intel Run Sure Technology increases system uptime and data integrity for your business-critical solutions. Hardware-embedded security features provide a safer environment and better protect data. • With Integrated PCI Express 3.0, the product family offers extra capacity and flexibility for storage and networking connections and provides up to twice the amount of I/O bandwidth. • The processor family offers advanced reliability features, including Machine Check Architecture Recovery, to automatically monitor, report, and recover from hardware errors to maintain data integrity and keep mission-critical services online.

Specifications

Cisco UCS B-Series Blade Servers are important components of the Cisco UCS environment and are enabled by Cisco UCS Manager and the Cisco UCS 6200 Series Fabric Interconnects, 5100 Series Blade Server Chassis, and 2200 Series Fabric Extenders.

Table 3 summarizes the specifications for the Cisco UCS B460 M4.

Table 3. Product Specifications

Item	Specification
Processors	4 Intel Xeon processor E7 v2, E7 v3, or E7 v4 product family
Processor cores	<ul style="list-style-type: none"> • Up to 24 cores per processor, varying by processor model • Full spectrum of the fastest Intel Xeon processors supporting power ranges from 115 to 165W and from 4 to 24 processor cores
Memory	<ul style="list-style-type: none"> • 96 DIMM slots (DDR3 with Intel Xeon E7 v2 and E7 v3 processor, DDR4 with Intel Xeon E7 v4 processor) • Maximum of 6 TB using 64GB DIMMs
Mezzanine adapter slots	6 (two dedicated for Cisco UCS VIC 1340)
Disk drives	Up to 4 front-accessible hard disk drives (HDDs) or solid state disks (SSDs)
SSD and disk-drive options	<ul style="list-style-type: none"> • 120GB, 480GB and 1.6TB 6Gb/s 7mm high SSDs (with Intel Xeon E7 v4 processors) • 120GB, 480GB and 960GB 6Gb/s SSDs (with Intel Xeon E7 v2 and E7 v3 processors) • 300GB, 450GB, 600GB and 1.2TB HDDs (with Intel Xeon E7 v2 and E7 v3 processors)
Maximum Internal storage	Up to 6.4 TB
Drive controller	<ul style="list-style-type: none"> • LSI SAS3004 12Gb/s RAID controller • RAID 0, 1 support
Flash memory	Two slots for Cisco Flexible Flash SD card
Management	Managed from the Cisco UCS 6200 Series Fabric Interconnects by Cisco UCS Manager software
Temperature: Operating	50 to 95°F (10 to 35°C)
Temperature: Nonoperating	-40 to 149°F (40 to 65°C)
Humidity: Operating	5 to 93% noncondensing
Humidity: Nonoperating	5 to 93% noncondensing
Altitude: Operating	0 to 10,000 ft (0 to 3000m); maximum ambient temperature decreases by 1°C per 300m
Altitude: Nonoperating	40,000 ft (12,000m)

Table 4 summarizes regulatory standards compliance.

Table 4. Regulatory Standards Compliance: Safety and EMC

Specification	Description
Regulatory compliance	Products should comply with CE Markings according to directives 2004/108/EC and 2006/108/EC
Safety	<ul style="list-style-type: none"> • UL 60950-1 No. 21CFR1040 Second Edition • CAN/CSA-C22.2 No. 60950-1 Second Edition • IEC 60950-1 Second Edition • EN 60950-1 Second Edition • EC 60950-1 Second Edition • AS/NZS 60950-1 • GB4943 2001
EMC: Emissions	<ul style="list-style-type: none"> • 47CFR Part 15 (CFR 47) Class A • AS/NZS CISPR22 Class A • CISPR2 2 Class A • EN55022 Class A • ICES003 Class A • VCCI Class A • EN61000-3-2 • EN61000-3-3 • KN22 Class A • CNS13438 Class A
EMC: Immunity	<ul style="list-style-type: none"> • EN55024 • CISPR24 • EN300386 • KN24

Warranty Information

Find warranty information at Cisco.com on the [Product Warranties](#) page.

Cisco Unified Computing Services

Using a unified view of data center resources, Cisco and our industry-leading partners deliver services that accelerate your transition to a unified computing environment. Cisco Unified Computing Services helps you quickly deploy your data center resources and optimize ongoing operations to better meet your business needs. For more information about these and other Cisco Data Center Services offerings, visit <http://www.cisco.com/go/dcservices>.

Why Cisco?

Cisco has significant experience in listening to customer requirements and providing solid technology innovation for the enterprise data center. Cisco delivers standards-based solutions backed by a broad partner ecosystem of industry leaders to provide end-to-end customer solutions. Unified computing elevates the traditional product classification of network, server, storage, operating systems, and applications to a data center-wide vision. Cisco, as one of the largest technology providers in the world, has the resources, expertise, and customer focus to deliver on the unified computing vision.

Cisco Capital

Financing to Help You Achieve Your Objectives

Cisco Capital can help you acquire the technology you need to achieve your objectives and stay competitive. We can help you reduce CapEx. Accelerate your growth. Optimize your investment dollars and ROI. Cisco Capital financing gives you flexibility in acquiring hardware, software, services, and complementary third-party equipment. And there's just one predictable payment. Cisco Capital is available in more than 100 countries. [Learn more.](#)

For More Information

For more information about Cisco UCS B-Series Blade Servers, visit or contact your local Cisco representative.



Americas Headquarters
Cisco Systems, Inc.
San Jose, CA

Asia Pacific Headquarters
Cisco Systems (USA) Pte. Ltd.
Singapore

Europe Headquarters
Cisco Systems International BV Amsterdam,
The Netherlands

Cisco has more than 200 offices worldwide. Addresses, phone numbers, and fax numbers are listed on the Cisco Website at www.cisco.com/go/offices.

Cisco and the Cisco logo are trademarks or registered trademarks of Cisco and/or its affiliates in the U.S. and other countries. To view a list of Cisco trademarks, go to this URL: www.cisco.com/go/trademarks. Third party trademarks mentioned are the property of their respective owners. The use of the word partner does not imply a partnership relationship between Cisco and any other company. (1110R)