

Cisco ONS 15454 100-Gbps CP-DQPSK Full C-Band Tunable DWDM Trunk Card

Product Overview

The Cisco® ONS 15454 Multiservice Transport Platform (MSTP) supports a 100-Gbps Full C-Band Tunable CP-DQPSK DWDM Trunk Card, which simplifies the integration and transport of 100 Gigabit Ethernet and OTU-4 interfaces and services into enterprises or service provider optical networks (Figure 1).

Release 9.6 of the Cisco ONS 15454 MSTP extends the total data transport capacity by a factor of three, allowing dense wavelength-division multiplexing (DWDM) transmission of up to 9.6 Tbps (96 services at 100 Gbps) in the C-band.

Figure 1. 100-Gbps Full C-Band Tunable CP-DQPSK DWDM Trunk Card



Challenge and Solution

The bandwidth carried on core and metropolitan DWDM networks is growing exponentially, while operators' revenues are not keeping pace. The Cisco ONS 15454 100-Gbps solution can dramatically lower the cost to carry bandwidth, helping to maintain and improve customers' profitability. Internet growth is still exponential, mainly because of demand for next-generation services such as quadruple play (data, voice, video, and mobility), video distribution, Internet Protocol Television (IPTV), and other high-bandwidth services.

Owing to advanced modulation techniques, the ability to transmit 100G wavelengths on existing or new DWDM systems maximizes return on investment by increasing the overall capacity per fiber pair without affecting the unregenerated transmission distance supported by the system. Scaling from 10 Gbps to 40 Gbps and now 100 Gbps multiplies by a factor of 10 the bandwidth that can be transported over existing fiber networks.

New coherent polarization-multiplexing differential quadrature phase shift keying (CP-DQPSK) modulation enables 9.6-Tbps capacity transmission over ultralong-haul (ULH) networks with more than 2,500 km of unregenerated optical spans.

The Cisco ONS 15454 MSTP 100-Gbps Full-Band Tunable CP-DQPSK DWDM Trunk Card is designed to provide the following benefits:

- 100-Gbps wavelength transport over fully uncompensated networks, with more than 2,500 km of unregenerated optical spans
- Enable 100-Gbps transport over very low-quality fiber with very high polarization mode dispersion (PMD)
- Support up to 96 100-Gbps wavelengths (50-GHz channels spacing) with very high tolerance to filtering penalties
- Improve overall system density up to 100 Gbps per slot, which is 5 times greater than the density achieved with 40-Gbps units
- Support a number of different configurations (transponder, muxponder, regenerator) through software provisioning only

Product Features and Benefits

The Cisco 100-Gbps Full-Band CP-DQPSK DWDM Trunk Card can transport 100GbE LAN-PHY and optical transport network (OTN) optical transport unit level 4 (OTU4) signals over a 50-GHz spaced, 50-GHz stabilized, ITU-compliant wavelength. The trunk card is a plug-in module to the Cisco ONS 15454 MSTP, providing a cost-effective architecture for delivering high-rate 100-Gbps services. The card also features a pluggable client interface that can be used to provide transponder capabilities, mapping the client signal to a single DWDM line interface.

The client port supports a standard CXP format pluggable compliant with 100GBASE-SR10 LAN PHY or OTU4 equivalent interface.

The trunk DWDM port features a software-configurable baud rate between 27.952 Gbaud and 31.241 Gbaud, depending on FEC selection, as well as a G.709v3 OTU4 digital wrapper, long-reach/long-haul, ITU-compliant, 50-GHz spaced optical interface using LC connectors. The DWDM output line interface is tunable to 96 wavelengths across the full optical C band, dramatically reducing inventories for spares. When operated within the outlined specifications, the CP-DQPSK DWDM trunk card can operate with a post-FEC bit error rate (BER) better than 10E-15.

The Cisco 100-Gbps Full-Band Tunable CP-DQPSK DWDM Trunk Card provides many carrier-class features and advanced capabilities necessary to deliver 100-Gbps services, including protocol transparency, wavelength tunability, flexible protection mechanisms, flow-through timing, and management and performance monitoring capabilities (Figure 2).

Figure 2. 100-Gbps Full-Band Tunable CP-DQPSK Transponder Card Block Diagram



Enhanced FEC Capability

The card can support a forward error correction (FEC) mechanism on trunk and client interfaces.

The trunk port supports three different software-configurable FEC coding options, which cannot be disabled:

- GFEC: Standard G.975 Reed-Solomon algorithm with 7 percent overhead (OH).
- UFEC: Standard G.975.1 (subclause I.7) with 20 percent overhead; this FEC scheme uses two orthogonally concatenated BCH super FEC codes. The constructed code is decoded iteratively to rebuild the original frame.
- HG-FEC: High-gain EFEC with 7 percent overhead, providing better performance than standard G.975.1 7 percent OH EFEC. This EFEC, owing to the reduced overhead and lower bit rate, is suitable for applications where 100G wavelengths are passing through a large number of ROADMs with limited pass-band performance.

The client port supports Standard G.975 Reed-Solomon FEC algorithm, which can be enabled or disabled through software configuration.

Advanced Modulation Scheme

Cisco 100-Gbps Full-Band Tunable CP-DQPSK DWDM Trunk unit features an advanced modulation scheme to provide optical performance significantly better than industry-standard 10-Gbps equivalent interfaces.

Cisco selected a coherent polarization-multiplexing differential quadrature phase shift keying (CP-DQPSK) modulation format to optimize 100-Gbps transmission in terms of optical signal-to-noise ratio (OSNR), chromatic dispersion, and PMD robustness.

The CP-DQPSK modulation scheme consists of multiplexing two DQPSK signals using two different orthogonal light polarizations, as shown in Figures 3 and 4.

Figure 3. CP-DQPSK Logical Modulation Scheme

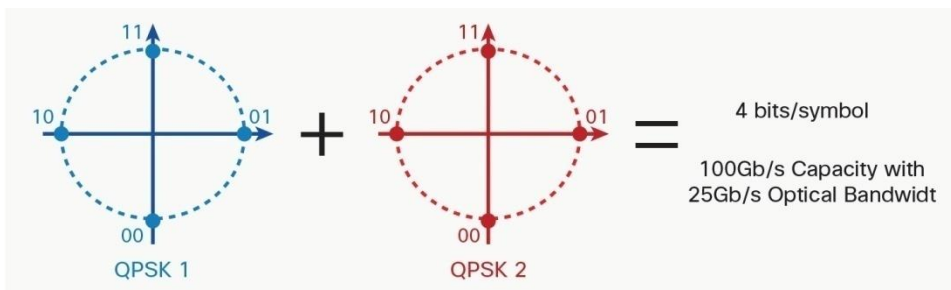
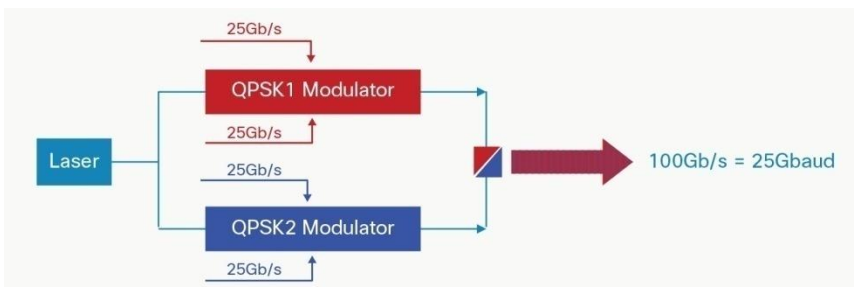
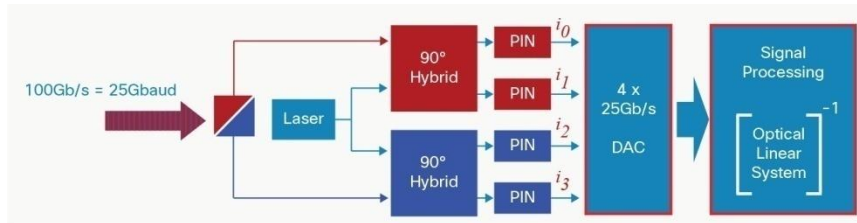

Figure 4. CP-DQPSK Logical Transmitter Scheme



The core of the 100-Gbps CP-DQPSK modulation scheme is the optical receiver, based on coherent optical detection, where a digital signal processor (DSP) calculates the inverse of the optical system matrix, allowing the receiver to recover the original transmitted signals (Figure 5).

Figure 5. CP-DQPSK Logical Receiver Scheme



The primary benefits of CP-DQPSK are:

- Strong OSNR performance
- Outstanding chromatic dispersion robustness allowing the avoidance of any optical chromatic dispersion compensation solution
- Extended PMD robustness (three times better than 10-Gbps units)
- Very high spectral efficiency, allowing 100G wavelengths to be transmitted across a large number of reconfigurable optical add-drop multiplexers (ROADMs) with negligible penalty

Transponder Card Versions

Two versions of the 100-Gbps Full-Band Tunable CP-DQPSK DWDM Trunk unit are offered to support different application requirements:

- An extended-performance version offering full performances targeting ULH applications where the network is optimized for CP-DQPSK transmission (no 10-Gbps channels or dispersion compensation units [DCUs])
- A metro edge performance version with differential mode only (CP-DQPSK), cost-optimized for metropolitan application and 10-Gbps installed networks

Protocol Transparency

The Cisco 100-Gbps Full-Band Tunable CP-DQPSK DWDM Trunk unit can deliver transparently any 100-Gbps services for cost-effective, point-to-point networking for the Cisco ONS 15454 platform. (See Table 1.)

Table 1. Transponder Client Configurations and Mapping

Client		Mapping	Trunk		
Format	Rate (Gbps)		Format	Rate with 7% GFEC or EFEC OH (Gbps)	Rate with 20% UFEC OH (Gbps)
100GE LAN-PHY	101.125	Bit transparent through standard G.709v3 mapping	OTU4	111.809	124.964
OTU4	111.809	Transparent G.709 standard			

Wavelength Tunability

The 100-Gbps DWDM Trunk card supports software-provisionable tunability across the full C-band, covering 96 channels on the 50-GHz grid. Tunability enables flexibility and reconfigurability of services transported on ROADM-based networks and also allows ordering and inventory of a single part for deployment and sparing.

Flexible Protection Mechanism Support

The 100-Gbps Full-Band Tunable CP-DQPSK DWDM Trunk card supports multiple protection mechanisms commonly used in optical transport networks. Table 2 outlines the available protection options and the associated service-level agreements (SLAs) that can be provided.

Table 2. Protection Formats

Protection Type	Capabilities
Unprotected	No client terminal interface, transponder card, or DWDM line protection. The client signal is transported over a single unprotected transponder card or optical path.
1+1 protection	Provides protection for the client terminal interface, transponder card, and DWDM line through client automatic protection switching (APS) or linear multiplex section protection (LMSP) signaling transported transparently over the transponder card or optical path. Protection is provided through client line or path protection through transparent signal transport through a transponder circuit.
OCH trail protection	Provides protection for DWDM signal through external optical switch units (protection switch module [PSM]).

Flow-Through Timing

The 100-Gbps DWDM Trunk card allows timing to flow through from client to line optical interface. The received timing from the client interface is used to time the line transmitter interface. This flow-through timing allows multiple 100-Gbps DWDM Trunk cards to be placed in the same shelf but to be independently timed, independent of the network element timing.

Management

Cisco ONS 15454 MSTP provides comprehensive management capabilities to support the operations, administration, maintenance, and provisioning (OAM&P) capabilities through the integrated Cisco transport controller craft interface with support from the Cisco Prime™ optical element management system. The 100-Gbps Full-Band Tunable CP-DQPSK DWDM Trunk Card features provisionable digital wrapper (G.709) functionality, providing per-wavelength performance management capabilities, especially for services transported transparently across the network. Without the digital wrapper functions, a carrier transporting a service transparently would be unable to identify network impairments, which may degrade the transported signal and violate the SLAs. The digital wrapper's generic communication channel (GCC) provides a separate communications channel on a per-wavelength basis to be used by the platform when transparent signals are transported. GCC allows the Cisco ONS 15454 system to extend its advanced network autodiscovery capabilities to DWDM-based services. The integrated Cisco Transport Controller craft manager and Cisco Prime optical provide the user with OAM&P functionalities for the system.

Far-End-Laser-Off Behavior

The Cisco 100-Gbps Full-Band Tunable CP-DQPSK DWDM Trunk Card can provision the far-end-laser-off behavior when SONET/SDH payloads are present. Customers can use Cisco Transport Controller to configure how the remote client interface will behave following a fault condition. It is possible to configure the remote client to squelch or to send an alarm indication signal (AIS).

For 100GbE signals the default behavior is squelching.

Performance Monitoring

The 100-Gbps DWDM Trunk provides support for both transparent and nontransparent signal transport performance monitoring. The digital wrapper channel is monitored according to G.709 (OTN) and G.8021 standards. Performance monitoring of optical parameters on the client and DWDM line interface include loss of signal (LOS), laser bias current, transmit optical power, and receive optical power. Calculation and accumulation of the performance monitoring data are supported in 15-minute and 24-hour intervals as per G.7710.

Physical system parameters measured at the wavelength level like mean PMD, accumulated chromatic dispersion or received OSNR are also included in the set of performance monitoring parameters. These can greatly simplify troubleshooting operations and enhance the set of data that can be collected directly from the equipment.

A detailed list of performance monitors is given in Table 7.

The 100-Gbps DWDM Trunk card incorporates faceplate-mounted LEDs to provide a quick visual check of the operational status of the card. An orange circle is printed on the faceplate, indicating the shelf slot in which you can install the card.

A specific configuration of the client will support IP-over-DWDM proactive fast reroute messaging over the CXP client in case of 100GbE connectivity with the ASR-9000 2-port 100G line card.

Regenerator Configuration

The Cisco 100-Gbps Full-Band Tunable CP-DQPSK DWDM Trunk Card supports OTU4 regeneration capabilities. Two cards can be configured to work in back-to-back mode connecting through the backplane in the same shelf, and perform the OTN optical-electrical-optical (OEO) regeneration of the frame, as depicted in Figure 6.

Figure 6. OTU4 Regeneration Configuration for 100G/OTU4 Client Signal

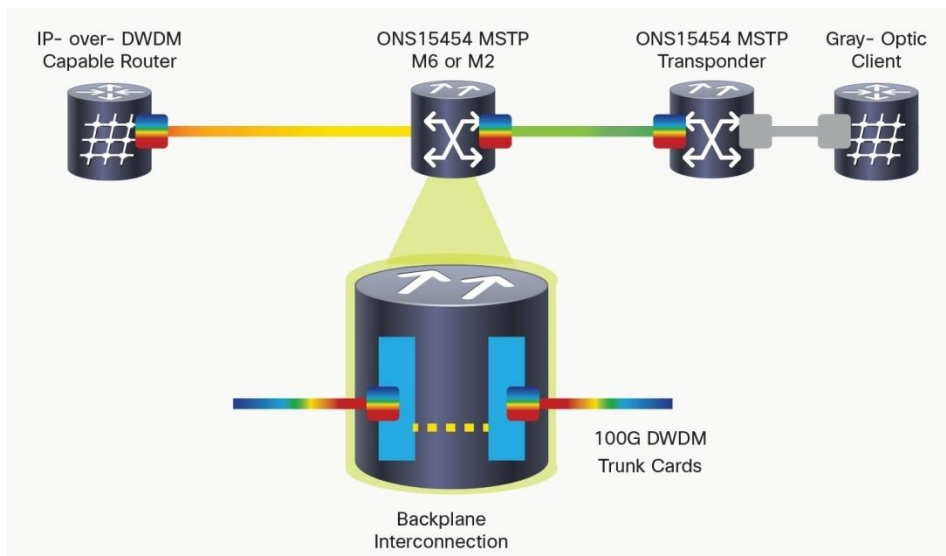

100GE or OTU4 clients are supported. Regeneration capability uses the OTU4 backplane interconnection supported by the ONS 15454 M6 or M2 chassis; OTU4 overhead is terminated, allowing ODU4 to transparently pass through. GCC0 is properly terminated, while GCC1 and GCC2 are properly passed through.

No CXP client is required as communication between the two cards acting as a regeneration group is supported through the chassis backplane.

A dedicated IP-over-DWDM configuration can be enabled in the regeneration configuration to support proactive fast reroute messaging between IP-over-DWDM router interfaces.

Figure 7. OTU4 Regeneration Configuration in an M2 Chassis

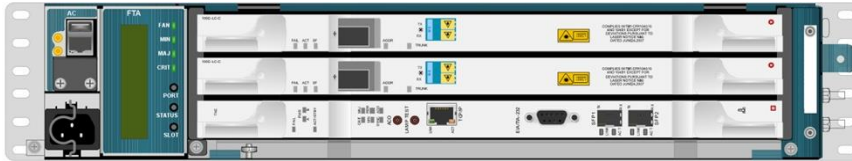

In case of failure on one side, ODUk-AIS is generated and propagated on the other side, while an OTUk-BDI is sent back on the same side as defined by the ITU G.709 standard.

10x10G Muxponder Configuration

The Cisco 100-Gbps Full-Band Tunable CP-DQPSK DWDM Trunk Card can be coupled with the 10x10G line card to support 10-port 10G muxponder capabilities. The 100G DWDM trunk card can be connected through the M6 or M2 backplane (no client CXP required) with the 10x10G line card to provide OTN multiplexing of the 10G data streams into a single 100G DWDM OTU4 wavelength.

Supported client signals are any combination of 10GbE LAN-PHY, 10GbE WAN-PHY, OC-192, STM-64, 10G FC/FICON, 8G FC/FICON, or OTU2 data rates.

For additional information, refer to the 10x10G line card data sheet.

Figure 8. Three 10x10G Muxponder Configurations in an M6 Chassis

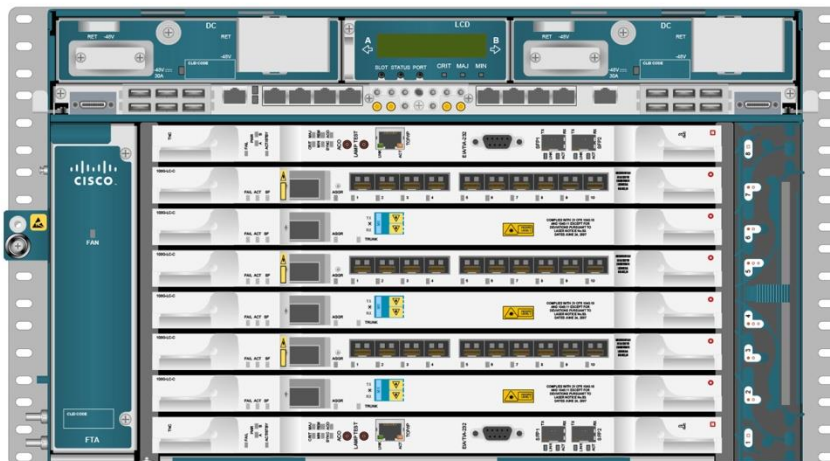

2x40G Muxponder Configuration

The Cisco 100-Gbps Full-Band Tunable CP-DQPSK DWDM Trunk Card can be coupled with the 2xCFP line card to support 2-port 40G muxponder capabilities. The 100G DWDM Trunk card can be connected through the M6 or M2 backplane (no client CXP required) with the 2xCFP line card and provides OTN multiplexing of the 40G data streams into a single 100G DWDM OTU4 wavelength.

Supported client signals are any mix and combination of 40GbE LAN-PHY or OTU3 data rates.

For additional information, refer to the 2xCFP line card data sheet.

100G LR4 Transponder Configuration

Cisco 100-Gbps Full-Band Tunable CP-DQPSK DWDM Trunk Card can be coupled with the 2xCFP line card to support 100GBASE-LR4 client interface for the 100-Gbps transponder. The 100G CXP pluggable available on the 100-Gbps DWDM Trunk Card currently supports only 100GBASE-SR10 client interface, while 100GBASE-LR4 can be supporting using a CFP form factor only.

The 2xCFP line card can be connected through the M6 or M2 backplane with up to 2 x 100G DWDM Trunk Cards placed in slots immediately above and below the trunk card to provide the functionality of two 100G LR4 transponders, using CFP pluggables as the client-facing interface.

Figure 9. Two 100G LR4 Transponder Configurations plus One 10x10G Muxponder in an M6 Chassis

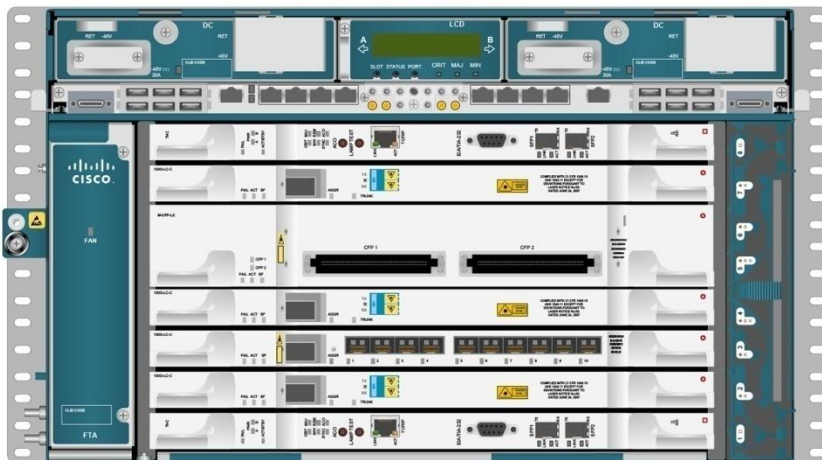

Supported client signals are 100GbE LAN-PHY or OTU4 data rates.

For additional information, refer to the 2xCFP line card data sheet.

Application Description

Cisco ONS 15454 MSTP 100-Gbps Full-Band Tunable CP-DQPSK DWDM Trunk Card adds the capability to cost-effectively transport 100-Gbps services using the Cisco ONS 15454 MSTP platform.

Two main applications are foreseen:

- 100-Gbps router interconnection for business services and research networks: Cisco research indicates that the total volume of worldwide IP traffic is doubling every two years, requiring an increase in transfer rate from 10 Gbps to 100 Gbps. The transponder solution aims at providing DWDM interconnection between 100-Gbps router interfaces across DWDM metro, regional, or ultralong-haul networks. The advanced CP-DQPSK modulation scheme is designed to cope with long-distance applications, allowing the extension of 100-Gbps services across more than 2,500 km unregenerated distance.
- OTU4 links in carrier backbone networks: OTN technology is crucial to backbone carrier networks. OTN is normally the preferred method used for intercarrier or interdomain capacity exchange at 2.5-Gbps (OTU1), 10-Gbps (OTU2), 40-Gbps (OTU3), and 100-Gbps (OTU4) data rates. Cisco 100-Gbps Full-Band Tunable CP-DQPSK DWDM Trunk supports a fully standard OTU4 client interface, which can be connected to any G.709-based OTN cross-connect, 100-Gbps router interface, or other 100-Gbps transponder interfaces.

Licensing Approach

The ONS 15454 MSTP 100-Gbps Full-Band Tunable CP-DQPSK DWDM Trunk Card includes the ability to cost-effectively transport 10G services using a pay-as-you-grow licensing model for the 10x10G muxponder application. A licensed version of the ONS 15454 MSTP 100-Gbps Full-Band Tunable CP-DQPSK DWDM Trunk Card works in conjunction with a licensed version of the 10x10G line card, offering a price-sensitive solution for aggregation and transport of 10G services. These two cards can only work in this configuration. Additional 10G services will be provided by mounting a 10G license through software key distribution. Up to nine 10G licenses can be added to the line card (one is provided in the initial configuration).

In order to simplify spares management, it is also possible to upgrade the licensed version of the trunk card to a full functionality one.

Table 3. Supported Software Licenses

License PID	License Description	Card Applicability	Card Description
15454-M-LIC-10G=	One Port 10G License for 100G Muxponder	15454-M-100GC-LIC=	100G OTU-4 ITU-T CP-DQPSK Full C Band Tunable LC - Licensed
15454-M-LIC-100G=	100G TXP/Reg License for 100G Trunk Line card	15454-M-10X10-LIC=	10x10G Multirate Client LC Licensed w/ 1 License at 10G

More information about the Cisco licensing policy is available at <http://www.cisco.com/en/US/docs/general/warranty/English/EU1KEN.html>.

Product Specifications

Compact Design

- Single slot card slot design for high-density, 100-Gbps solutions
- Up to six 100-Gbps DWDM Trunk cards per ONS 15454 M6 shelf assembly, supporting up to 42 100-Gbps interfaces per 42-rack unit (RU) bay frame

Flexible Restoration Options

- Transparent support for UPSR/SNCP, BLSR/MS-SPRing, and 1+1 APS/MSP
- OCH-trail protection through protection switch module
- Unprotected (0+1)

Tables 3 and 4 list the regulatory compliance and system requirements for the 100-Gbps DWDM Trunk card. Table 5 provides the DWDM specifications, Table 6 details receive-side optical performances, Table 7 lists performance monitoring parameters, Table 8 provides card specifications, and Table 9 includes ordering information for the card.

Regulatory Compliance

Important: All compliance documentation might not be completed at the time of product release. Check with your Cisco sales representative for countries other than Canada, the United States, and the European Union.

Table 4. Regulatory Compliance

ANSI System	ETSI System
Countries Supported	
<ul style="list-style-type: none"> • Canada • United States • Korea • Japan • European Union 	<ul style="list-style-type: none"> • European Union • Africa • CSI • Australia • New Zealand • China • Korea • India • Saudi Arabia • South America
EMC (Class A)	
<ul style="list-style-type: none"> • ICES-003, 2004 • GR-1089-CORE Issue 4, NEBS EMC and Safety, June 2006 • FCC 47CFR15, 2007 	<ul style="list-style-type: none"> • ETSI EN 300 386 V1.4.1 (2008-04) Telecommunication network equipment EMC requirements (Note: EMC-1) • CISPR22:2008 and EN55022:2006/A1:2007 Information Technology Equipment (Emissions) (EMC-2) • CISPR24: 1997/A1:2001/A2:2002 and EN55024:1998/A1:2001/A2:2003: Information Technology Equipment - Immunity characteristics - Limits and Methods of Measurement (test levels)
Safety	
<ul style="list-style-type: none"> • CSA C22.2 #60950-1 - Edition 7, March 2007 • UL 60950-1 - Edition 2, March 2007 • GR-1089-CORE Issue 4, NEBS EMC and Safety, June 2006 	<ul style="list-style-type: none"> • UL 60950-1 - Edition 2, March 2007 • IEC 60950-1 Information technology equipment Safety Part 1: General requirements - Edition 2, 2005 and National Differences as per CB Bulletin 112A • IEC/EN 60950-1 (2006/10) with Amendment 11:2004 to EN 60950-1:2001, 1st Edition and National Differences as per CB Bulletin 112A • EN 60950-1, Edition 2 (2006) Information technology equipment – Safety – Part 1: General requirements • CE Safety Directive: 2006/95/EC
Laser	
<ul style="list-style-type: none"> • UL 60950-1 - Edition 2, March 2007 • IEC 60825-1: 2001 Ed.1.2 (incl. am1+am2) Safety of laser products Part 1: Equipment classification, requirements and users guide • IEC60825-2 Ed.3 (2004) Safety of laser products Part 2: Safety of optical fiber communication systems + A1:2006 	<ul style="list-style-type: none"> • IEC 60825-1: 2001 Ed.1.2 (incl. am1+am2) Safety of laser products Part 1: Equipment classification, requirements and users guide • IEC60825-2 Ed.3 (2004) Safety of laser products Part 2: Safety of optical fibre communication systems + A1:2006 • 21CFR1040 (2008/04) (Accession Letter and CDRH Report) Automatic Laser Shutdown and restart (ALS) according to ITU-T G.664 (03/06). Guidance for Industry and FDA Staff (Laser Notice No. 50), June 2007 • Laser Products – Conformance with IEC 60825-1 and IEC 60601-2-22; Guidance for Industry and FDA Staff (Laser Notice No. 50), June 2007

ANSI System	ETSI System
Environmental	
<ul style="list-style-type: none"> GR-63-CORE Issue 3, NEBS Physical Protection, March 2006 	<ul style="list-style-type: none"> ETS 300-019-2-1 V2.1.2 (Storage, Class 1.1) ETS 300-019-2-2 V2.1.2 (1999-09): Transportation, Class 2.3 ETS 300-019-2-3 V2.2.2 (2003-04):Operational, Class 3.1E
Optical	
<ul style="list-style-type: none"> GR-253-CORE - Issue 04 ITU-T G.691 	<ul style="list-style-type: none"> ITU-T G.709 ITU-T G.975
Quality	
TR-NWT-000332, Issue 4, Method 1 calculation for 20-year mean time between failure (MTBF)	
Miscellaneous	
<ul style="list-style-type: none"> GR-1089-CORE Issue 4, NEBS EMC and Safety (June 2006) (Note: NEBS-1) GR-63-CORE Issue 3, NEBS Physical Protection (March 2006) (Note: NEBS-2) ATT-TP-76200: 2008 ANSI T1.315-2001 GR-499: 2004 Transport Systems Generic Requirements (TSGR): Common Requirements 	

Table 5. System Requirements

Component	Cisco ONS15454 M6	Cisco ONS15454 M2	Cisco NCS 2002	Cisco NCS 2006	Cisco NCS 2015
Processor	TNC/TSC/TNC-E/TSC-E	TNC/TSC/TNC-E/TSC-E	TNC-E/TSC-E/TNCS	TNC-E/TSC-E/TNCS/TNCS-O	TNC-E/TSC-E/TNCS/TNCS-O
Shelf assembly	15454-M6-SA shelf assembly with FTA2	15454-M2-SA shelf assembly with FTA2	NCS 2002 shelf assembly	NCS 2006/shelf assembly	NCS 2006/shelf assembly
System software	Release 9.6 ANSI/ETSI or later	Release 9.6 ANSI/ETSI or later	Release 9.6 ANSI/ETSI or later	Release 9.6 ANSI/ETSI or later	Release 10.5.x ANSI/ETSI or later
Slot compatibility	2 through 7	2 through 3	2 through 3	2 through 7	2 through 14

Table 6. DWDM Specifications

Parameter	Value
Bit rate	27.952 Gbaud \pm 20 ppm (OTU4 with GFEC or HG-FEC 7% OH) 31.241 Gbaud \pm 20 ppm (OTU4 with UFEC 20% OH)
Automatic Laser Shutdown and restart	ITU-T G.664 (06/99)
Nominal wavelengths (λ_{Tnom})	Full tunable between 1528.77 and 1566.72nm (C-Band – 50 GHz)
Connector type (TX/RX)	LC, duplex (shuttered)
Optical Transmitter	
Type	CP-DQPSK modulation format
Output Power (P_{Tmin})	
LH Version	-1 to +1.5dBm
Metro Version	-2 to +0.5dBm
Required Optical Return Loss, minimum (ORL_{min})	27 dB
Laser Safety Class	1
Optical Receiver	
Chromatic dispersion tolerance (DLR_{max})	+/- 70,000ps/nm
Overload	0dBm
Receiver reflectance (maximum)	30dB
Input wavelength bandwidth ($\lambda_{c,rx}$)	Between 1528.77 and 1566.72nm (C-Band – 50 GHz)

Table 7. DWDM Receive-Side Optical Performances

CD Tolerance	FEC Type	Pre-FEC BER	Post-FEC BER	Input Power Sensitivity	DGD	OSNR (0.5 nm RWB)
Extended Performance						
0 ps/nm	EFEC (20% OH)	<1x10E(-2)	<10E(-15)	0 to -14dBm (-20dBm with 0.5dB of OSNR penalty)	-	7.5dB
0 ps/nm					180ps	8.0dB
+/- 70,000 ps/nm					180ps	9.0dB
0 ps/nm	HG-FEC (7% OH)	<4.0x10E(-3)	<10E(-15)	0 to -14dBm (-20dBm with 0.5dB of OSNR penalty)	-	8.0dB
0 ps/nm					180ps	8.5dB
+/- 70,000 ps/nm					180ps	9.5dB
Metro Edge Performance						
0 ps/nm	EFEC (20% OH)	<1x10E(-2)	<10E(-15)	0 to -14dBm (-20dBm with 0.5dB of OSNR penalty)	-	10.5dB
+/- 5,000 ps/nm					10ps	11.0dB
0 ps/nm	HG-FEC (7% OH)	<4.0x10E(-3)	<10E(-15)	0 to -14dBm (-20dBm with 0.5dB of OSNR penalty)	-	11.0dB
+/- 5,000 ps/nm					10ps	11.5dB

Table 8. Performance Monitoring Parameters

Area	Parameter Name		Description
OTN	OTUk SM	ODUk PM	
	BBE-SM	BBE-PM	Number of background block errors
	BBER-SM	BBER-PM	Background block error ratio
	ES-SM	ES-PM	Number of errored seconds
	ESR-SM	ESR-PM	Errored seconds ratio
	SES-SM	SES-PM	Number of severely errored seconds
	SESR-SM	SESR-PM	Severely errored seconds ratio
	UAS-SM	UAS-PM	Number of unavailable seconds
	FC-SM	FC-PM	Number of failure counts
FEC	Bit errors		Number of corrected bit errors
	Uncorrectable Words		Number of uncorrectable words
Trunk optical PM	OPT		Transmit Optical Power
	LBC		Transmitter Laser Bias Current
	OPR		Receiver Optical Power
	RCD		Residual Chromatic Dispersion
	PMD		Mean Polarization Mode Dispersion
	OSNR		Optical Signal to Noise Ratio, calculated with 0.5nm RBW

Table 9. Card Specifications

Management	
Card LEDs	
Failure (FAIL)	Red
Active/standby (ACT/STBY)	Green/yellow
Signal fail (SF)	Yellow
Client port LEDs (per port)	
Active input signal	Green
DWDM Port LEDs	
Active input signal	Green
Output wavelength	Green
Power (including pluggable)	
Typical	125W (25C & -48VDC)
Maximum	133W (55C & -38VDC)
Physical	
Dimensions	Occupies 1 slot
Weight	1.8kg (4 pounds)
Reliability and availability	
Mean time between failures (MTBF)	121,957hrs
Latency (end to end)	
G.709 - Standard FEC	4 microseconds
G.709 – HG-FEC 7%	24 microseconds
G.709 – UFEC 20%	39 microseconds
Storage temperature	-40° C to 70 C (-40 °F to 158 °F)
Operating temperature	
Normal	0°C to 40° C (32° F to 104° F)
Short term ¹	-5° C to 55° C (23° F to 131 F)
Relative humidity	
Normal	5% to 85%, noncondensing
Short term ¹	5% to 90% but not to exceed 0.024 kg water/kg of dry air
¹ Short-term refers to a period of not more than 96 consecutive hours and a total of not more than 15 days in 1 year (a total of 360 hours in any given year, but no more than 15 occurrences during that 1-year period). The values shown are valid for M6 or M2 chassis.	

Table 10. Ordering Information

Part Number	Description
15454-M-100G-LC-C=	100G OTU-4 ITU-T CP-DQPSK Full C Band Tunable LC
15454-M-100G-ME-C=	100G OTU-4 CP-DQPSK Full C Band Tunable LC Metro Edge
15454-M-100G-LIC=	100G OTU-4 ITU-T CP-DQPSK Full C Band Tunable LC - Licensed
15454-M-LIC-100G=	100G TXP/Reg License for 100G Trunk Line card
ONS-CXP-100G-SR10=	CXP - 100GBASE-SR - Commercial Temp

Cisco Capital

Financing to Help You Achieve Your Objectives

Cisco Capital[®] financing can help you acquire the technology you need to achieve your objectives and stay competitive. We can help you reduce capital expenditures (CapEx), accelerate your growth, and optimize your investment dollars and ROI. Cisco Capital financing gives you flexibility in acquiring hardware, software, services, and complementary third-party equipment. And there's just one predictable payment. Cisco Capital financing is available in more than 100 countries. [Learn more.](#)

For More Information

For more information about the ONS15454 MSTP, visit <http://www.cisco.com/en/US/products/hw/optical/ps2006/ps5320/index.html>.



Americas Headquarters
Cisco Systems, Inc.
San Jose, CA

Asia Pacific Headquarters
Cisco Systems (USA) Pte. Ltd.
Singapore

Europe Headquarters
Cisco Systems International BV Amsterdam,
The Netherlands

Cisco has more than 200 offices worldwide. Addresses, phone numbers, and fax numbers are listed on the Cisco Website at www.cisco.com/go/offices.

Cisco and the Cisco logo are trademarks or registered trademarks of Cisco and/or its affiliates in the U.S. and other countries. To view a list of Cisco trademarks, go to this URL: www.cisco.com/go/trademarks. Third party trademarks mentioned are the property of their respective owners. The use of the word partner does not imply a partnership relationship between Cisco and any other company. (1110R)