

Инновации беспроводных решений Cisco

Юрий Довгань,

Системный инженер

ydovgan@cisco.com

Что такое W.E.C.A.?



Welcome to WECA

WHAT'S NEW

Что такое W.E.C.A.?

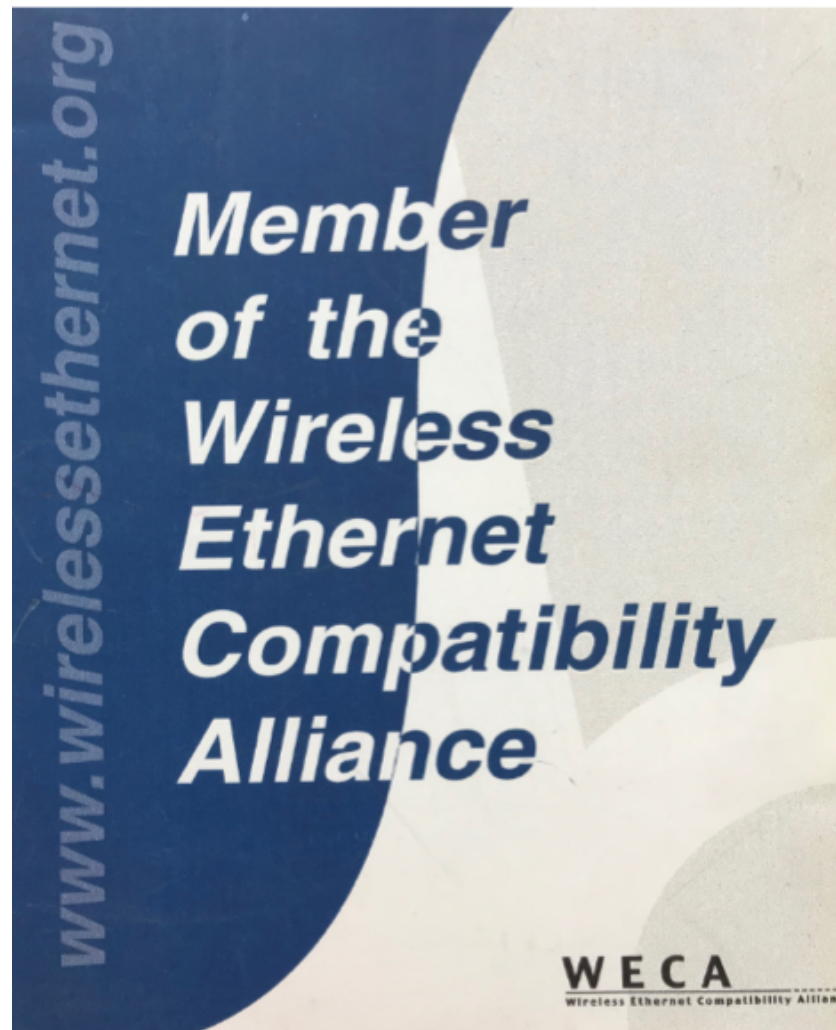

20 лет инноваций



4800 TURBO DS (1998)



Cisco Aironet® 4800 (2018)

Содержание

- Беспроводные инновации – на чем фокусируемся?
- Радио инновации
 - Введение в 802.11ax
 - Точка доступа AP 4800
- Wireless Assurance
 - Apple iOS аналитика
 - Streaming Telemetry
 - Беспроводные сенсоры
 - Интеллектуальный захват пакетов
- Что дальше?



Беспроводные инновации Cisco - Фокус

Radio



- Software Defined Radio
- Telemetry
- 802.11ax

Infrastructure



- AireOS: still investing
- Programmability
- Next Gen WLC
- Cloud & Virtualization

Solution



- SD-Access
- Assurance
- IoT/5G

Security



Insights: Analytics & Machine Learning



Радио инновации

Введение в 802.11ax

Radio Technologies

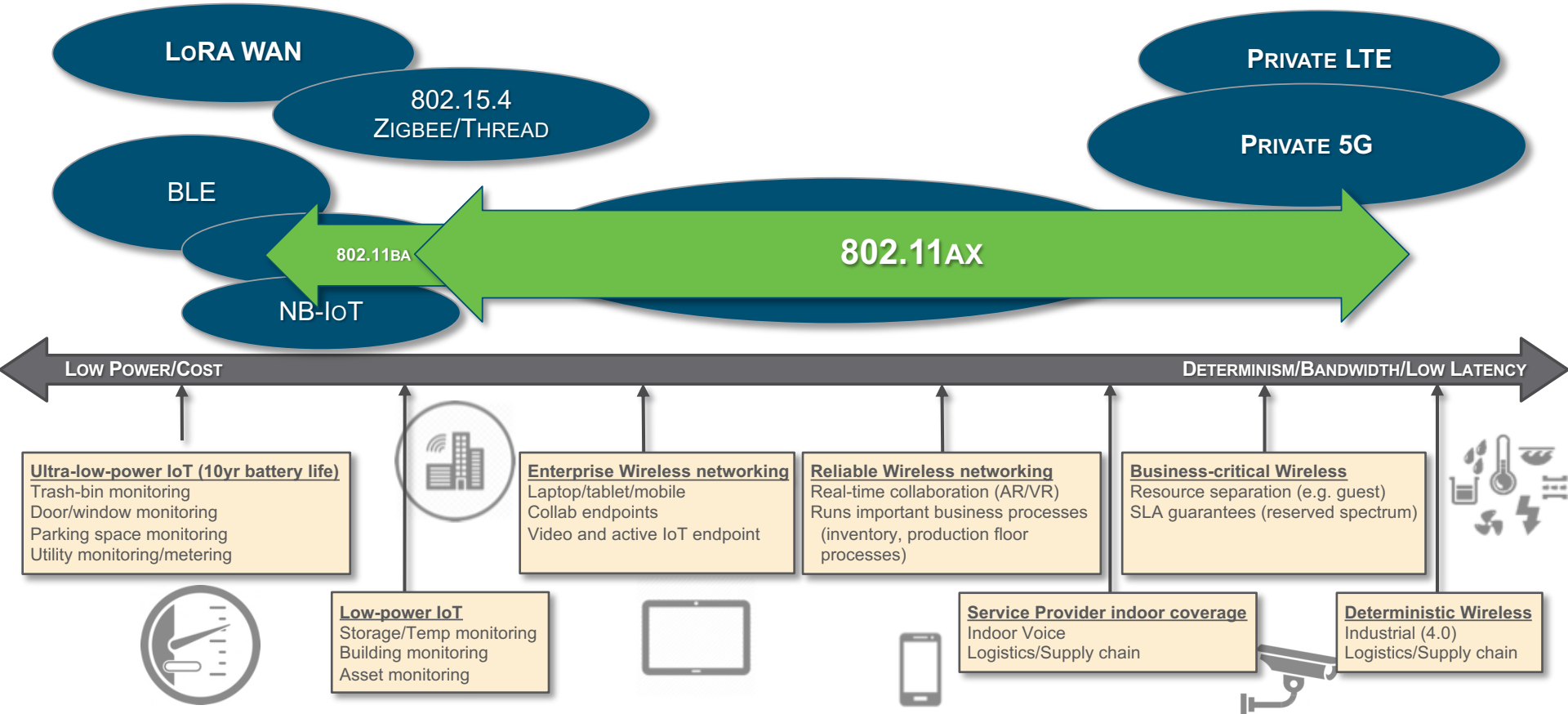

Orthogonal Frequency Division Multiple Access (OFDMA) vs. OFDM

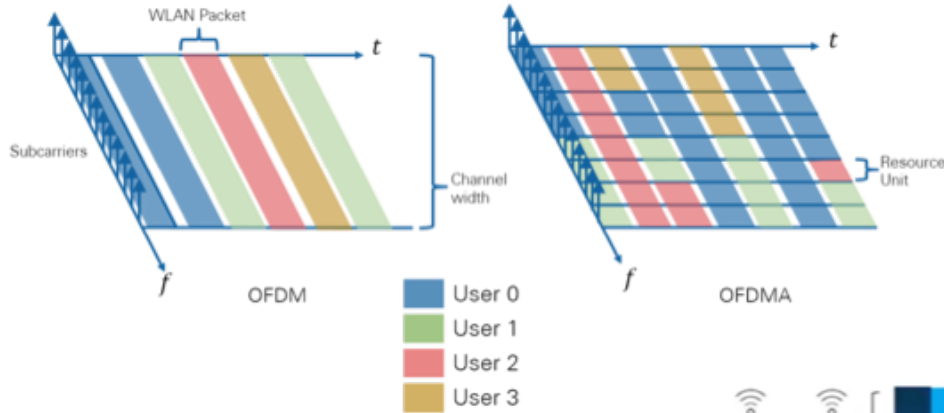

How it works:

- OFDMA divides the existing 802.11 channels (20, 40, 80 and 160 MHz wide) into smaller sub-channels with a predefined number of subcarriers (RU)
- AP decides how to allocate the channel. It may allocate the whole channel to only one user at a time – just as 802.11ac currently does – or it may partition it to serve multiple users simultaneously

The advantage:

- More capacity for the same channel utilization
- Less channel utilization for the same transmission, less CCI interference
- More predictive

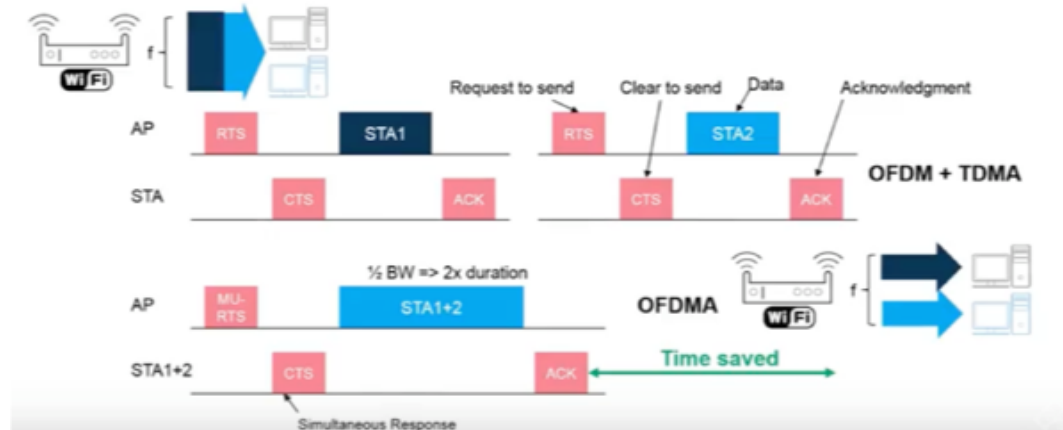

Orthogonal Frequency Division Multiple Access (OFDMA) vs. OFDM

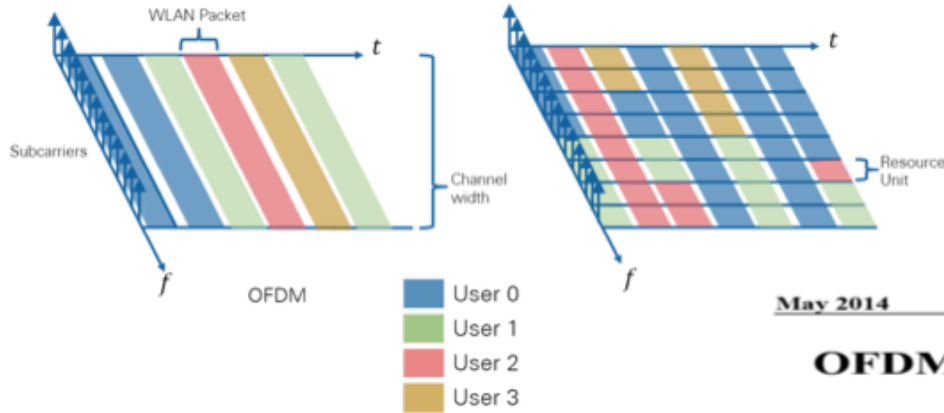

The advantage:

- More capacity for the same channel utilization
- Less channel utilization for the same transmission, less CCI interference
- More predictive

How it works:

- OFDMA divides the existing 802.11 channels (20, 40, 80 and 160 MHz wide) into smaller sub-channels with a predefined number of subcarriers
- AP decides how to allocate the channel. It may allocate the whole channel to only one user at a time – just as 802.11ac currently does – or it may partition it to serve multiple users simultaneously

May 2014

doc.: IEEE 802.11-14/1227r2

OFDMA throughput vs Number of STAs

- More active STAs achieve higher throughput gain
- The number of active STAs restricted by delay and overhead
- 10-20 active STAs can achieve quite good throughput gain
- We use 10 active STAs in the following simulations.

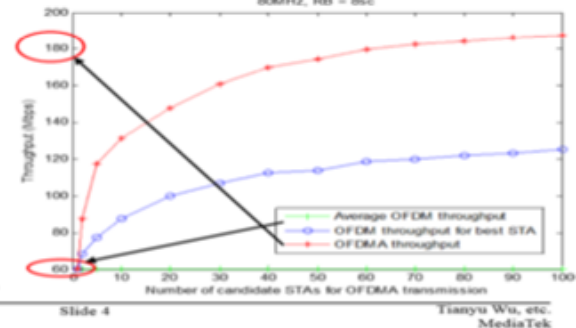

Submission

Multi-User MIMO (MU-MIMO)

Как работает и каковы преимущества?

Любят приводить аналогию с «хабом» и «коммутатором»

Клиенты с поддержкой MU-MIMO получают выгоды в лучшей суммарной полосе пропускания (в направлении downstream)

This is Single-User MIMO

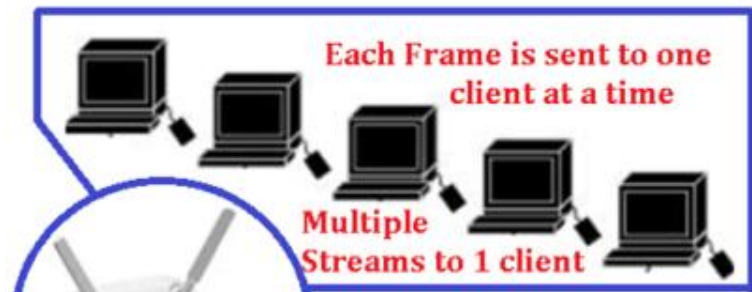

Spatial Streams are limited to the # of receivers on the client
Any additional radios on the AP are used for beamforming -
Note: older 11a/g/n clients are beamformed using ClientLink

This is Multi-User MIMO

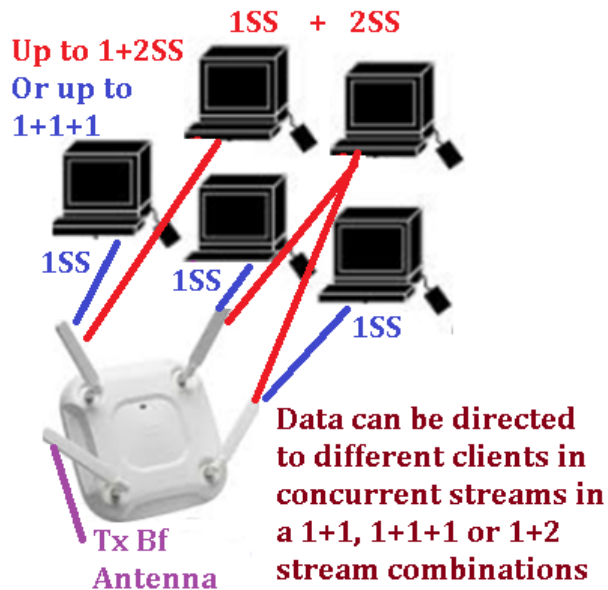

Max 3SS simultaneously

802.11ax MU-MIMO: Downlink and Uplink!

DOWNLINK MU_MIMO

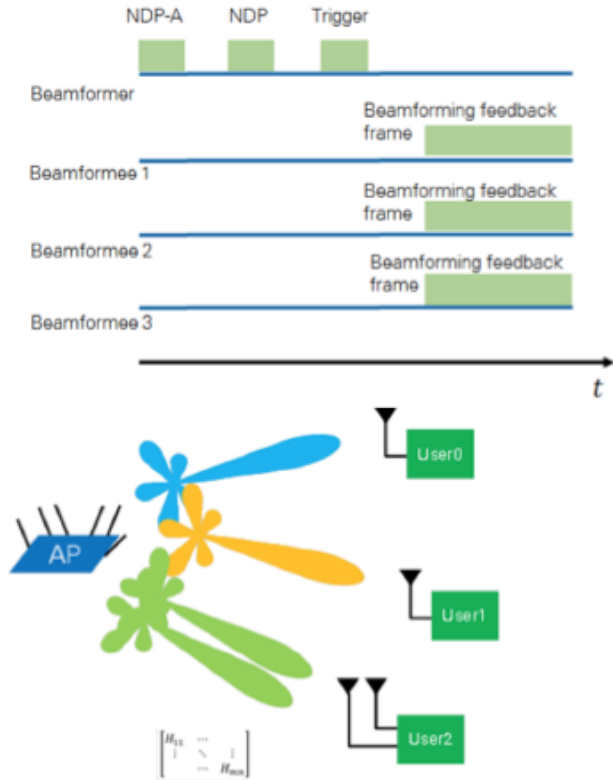

UPLINK MU_MIMO

Management of STAs is necessary

(RU allocation, length, bandwidth, simultaneous transmission)

- AP sends **trigger frame**
- Trigger Frame contains configuration for all STAs
- All STAs must start **Tx** simultaneously
- All STAs use identical frame length

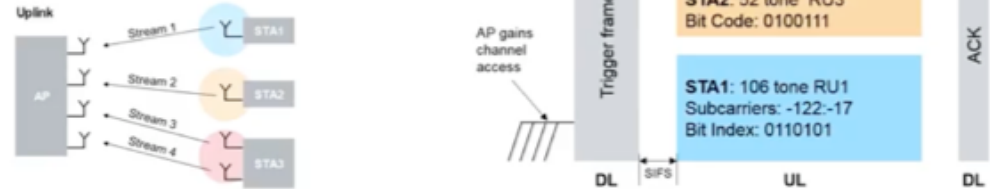

What speed can I get with 802.11ax?

MCS Index	Modulation	# of Spatial Streams	Bandwidth (MHz)	PHY rate (Mbps)		MAC Throughput (Mbps)*	
				1600ns GI	800ns GI	1600ns GI	800ns GI
8	256	1	20	98	103	69	72
9	256	1	20	108	115	76	81
10	1024	1	20	122	129	85	90
11	1024	1	20	135	143	95	100
8	256	2	20	196	206	137	144
9	256	2	20	216	230	151	161
10	1024	2	20	244	258	171	181
11	1024	2	20	270	286	189	200
8	256	4	20	392	412	274	288
9	256	4	20	432	460	302	322
10	1024	4	20	488	516	342	361
11	1024	4	20	540	572	378	400
8	256	8	20	784	824	549	577
9	256	8	20	864	920	605	644
10	1024	8	20	976	1032	683	722
11	1024	8	20	1080	1144	756	801
8	256	1	80	408	432	286	302
9	256	1	80	453	480	317	336
10	1024	1	80	510	540	357	378
11	1024	1	80	567	600	397	420
8	256	2	80	816	864	571	605
9	256	2	80	906	960	634	672
10	1024	2	80	1020	1080	714	756
11	1024	2	80	1134	1200	794	840
8	256	4	80	1632	1728	1142	1210
9	256	4	80	1812	1920	1268	1344
10	1024	4	80	2040	2160	1428	1512
11	1024	4	80	2268	2400	1588	1680
8	256	8	80	3264	3456	2285	2419
9	256	8	80	3624	3840	2537	2688
10	1024	8	80	4080	4320	2856	3024
11	1024	8	80	4536	4800	3175	3360
8	256	1	160	817	865	572	606
9	256	1	160	907	961	635	673
10	1024	1	160	1021	1081	715	757
11	1024	1	160	1134	1201	794	841
8	256	2	160	1634	1730	1144	1211
9	256	2	160	1814	1922	1270	1345
10	1024	2	160	2042	2162	1429	1513
11	1024	2	160	2268	2402	1588	1681
8	256	4	160	3268	3460	2288	2422
9	256	4	160	3628	3844	2540	2691
10	1024	4	160	4084	4324	2859	3027

- This theoretical because tests have not started
- What's the efficiency? For sure better than 60% but not yet known
- Will an mGig port be enough? It should in real world
 - 80Mhz/8x8/ 1024 QAM you'd get over 3Gbps on 5Ghz and you could add another 400 Mbps for 2.4. That means less than 4Gbps
 - Dual 5Ghz/4x4/80Mhz/1024 QAM total throughput may reach 3.2-3.3, still less than 4Gbps.

В то же время....



Wireless Controller Portfolio

Large Enterprise

Mid-size Enterprise

Small Network

Mobility Express
50 APs/1000 Clients AP 18xx
100 AP/2000 Clients: AP2/3K



Cisco 3504
150 APs
3000 Clients
4 Gbps



Cisco 5520
1500 APs
20,000 Clients
20 Gbps



Cisco vWLC
3000 APs
32000 Clients
Flexconnect mode



Cisco 8540
6000 APs
64,000 clients
40 Gbps



DNA-ready

DNA-ready

DNA-ready

Up to 100 APs

Up to 3000 APs

Up to 6000 APs

Cisco Aironet Portfolio – Adding a New Tier

The best infrastructure leads to the best outcomes

Good – Enterprise class

Better

Best in class

Ideal for small to medium-sized deployments

Mission critical

High density



1815 Series

Indoor/high-powered Indoor Wall plate/telemworker

- 2x2:2 SS 80 MHz
- 867 Mbps performance
- Tx beamforming
- Integrated BLE¹
- Max transmit power (dBm) per local regulations²
- 3 GE local ports, including 1 PoE out³
- Local ports 802.1X ready³
- USB 2.0⁴



1830/1850 Series

- 3x3:2 SS 80 MHz/4x4:3 SS 80 MHz
- 867 Mbps or 1.7 Gbps performance
- 1 or 2 GE ports uplink
- Internal or external antenna (1850)
- Tx beamforming
- USB 2.0



2800 Series

- 4x4:3 SS 160 MHz
- 5 Gbps performance
- 2.4 and 5 GHz or dual 5 GHz
- 2 GE ports uplink
- Cisco CleanAir® and ClientLink
- Internal or external antenna
- Smart antenna connector
- USB 2.0



3800 Series

- 4x4:3 SS 160 MHz
- 5 Gbps performance
- 2.4 and 5 GHz or dual 5 GHz
- 2 GE ports uplink or 1 GE + 1 Multigigabit (5G)
- Cisco CleanAir and ClientLink
- StadiumVision™
- Internal or external antenna
- Smart antenna connector
- USB 2.0
- Modularity for investment protection



4800

- 4 embedded radios (3 Wi-Fi and 1 BLE)
- 4x4:3 SS 160 MHz
- 5 Gbps performance
- 2.4 and 5 GHz or dual 5 GHz
- 2 GE ports uplink or 1 GE + 1 Multigigabit (5G)
- Embedded Hyperlocation
- Real-time analytics and packet capture
- Cisco CleanAir and ClientLink
- Internal antenna
- USB 2.0
- Integrated BLE

¹ Future availability

² Available for high-powered only

³ Available for wall plate and telemworker only

⁴ Available for telemworker only

HW and SW Platform supported in 8.7

Product	H/W Platform Supported
AP Modules	Hyperlocation Module, WSSI & WSM module, 3 rd Party Ecosystem modules
Supported APs	Legacy Wave-1 APs: 3700, 2700, 1700, 702, 702W, 1530, 1570 Wave-2 APs: 1800 series, 2800 series, 3800 series, 4800 series (8.7.x); 1540, 1560 *802, *1600, *2600, *3600, *3500, *1550
WLC	ME, 3504, 5520, 8540, vWLC Small and Large; *2504, *5508, *WiSM2 and *7510
MSE, CMX	3365, Virtual Appliance with CMX 10.4/10.5, CMX Engage, MSE 8.0.130 and MSE/wIPS 8.0
ISE	ISE release 2.3
Cisco Prime	Prime release 3.4
DNAC	DNAC version 1.2

***Not Supported in 8.7 release. Last supported release is 8.5**

For additional Interoperability Details See Compatibility Matrix link

<https://www.cisco.com/c/en/us/td/docs/wireless/compatibility/matrix/compatibility-matrix.html>

New

Next-Generation Wave 2 802.11ac Access Point



Cisco Aironet® 4800

- Industry leading 4x4 MIMO:3 spatial streams (SS) **Wave 2** 802.11ac access points
- Tri-radio, 802.11ac Wave 2, 160 MHz
- **Built-in BLE Radio**
- Combined Data Rate of 5.2Gbps
- 2 x 5 GHz: 4x4: 3SS supporting
 - SU-MIMO / MU-MIMO
 - Flexible Radio Assignment: 2.4GHz, Dual-5GHz, Wireless Security Monitoring, and DNA-C Assurance
- 1 x 2.4GHz/5GHz for DNA Analytics, Wireless Security monitoring, and Hyperlocation
- Gigabit Ethernet and multi-Gigabit Ethernet (1G, 2.5G, 5G)
- Built-in Hyperlocation Antenna Array 16-elements <3m Accuracy (median)
- **HDX Technology**
- USB 2.0
- Analytics-enabled, DNA Ready



Redefining Analytics and Location

Access Point AP-4800

Combines Cisco's Best AP Innovations along with the core features of the Cisco-Aironet AP-3800, DNA Analytics & Hyperlocation AP

**SOLVES THE PROBLEM OF WHICH
TECHNOLOGY TO DEPLOY**



Redefining RF Excellence
No Hardware Equal – The Best

Best in Class Wave-2 AP “or” Best in Class Location Based Services AP?

Customers had to choose which technology to deploy or perhaps deploy an overlay?...



AP-2800 or AP-3800 Wave-2

- 802.11ac Wave 2: High-Performance 5Gbps.
- 2.4, 5GHz or Dual 5GHz.
- 4x4:3SS 160MHz.
- MU-MIMO
- 2 GE or 1 GE + 1 mGig (5G)
- Flexible Radio Architecture
- Dual 5 GHz
- DNA Sensor, Spectrum Intelligence and more...

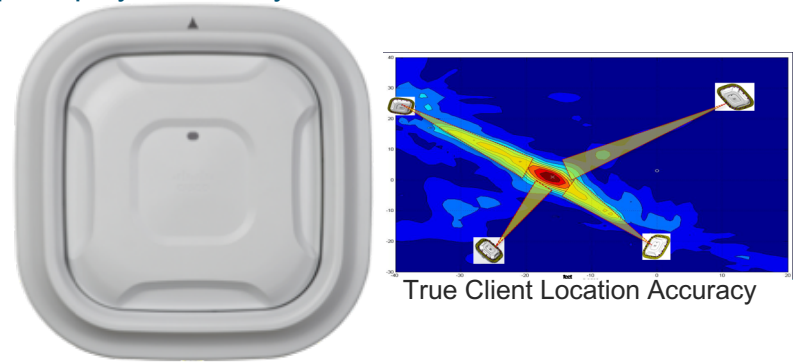

AP-3600 or AP-3700
With Hyperlocation module

- Analytics, Asset tracking, Proximity Marketing
- Navigation and Wayfinding “true blue dot” experience
- 1 to 3 meter location accuracy (Wi-Fi Clients)
- BLE Beacon – Five centrally managed Beacons
- FastLocate – Frequent location updates (Wi-Fi Clients)
- Spectrum Intelligent Monitoring Radio and more...

Combining Proven Technologies

Hyperlocation + AP-3800i + Additional Analytics Radio = AP-4800

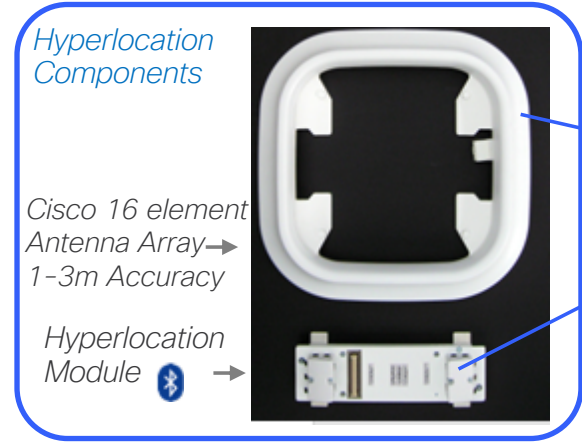

AP-4800 Integrated Solution



AP-3800
Dual 5GHz
Monitor/Sensor

Proven Hyperlocation + 3800 Technology in one AP & 1 cable Drop

Improved Capability

- 802.11acW2
- WiFi & BLE AoA
- Time Based solutions
- + All the core features of the AP-3800



Hyperlocation
AP36/3700

12x12"

40% smaller

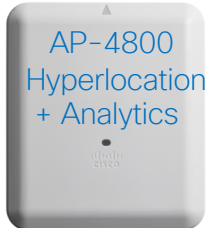

AP-4800
Hyperlocation
+ Analytics

9.9x8.7"



Hyperlocation
Components

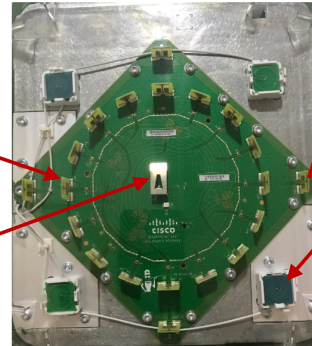

Inside AP-4800
Dual 5GHz XOR + another analytics
Hyperlocation XOR radio



Antenna components

Микро/Макро соты

Один 5 GHz радиointерфейс



- Чем дальше клиент от ТД, тем меньшую скорость он будет получить
- Скорость является функцией от SNR (сигнал/шум)
- Чем выше SNR, тем выше скорость передачи
- 1 x 5 GHz сота имеет ограниченное эфирное время для передачи
- Емкость – это сумма всех клиентов в соте в контексте эфирного времени

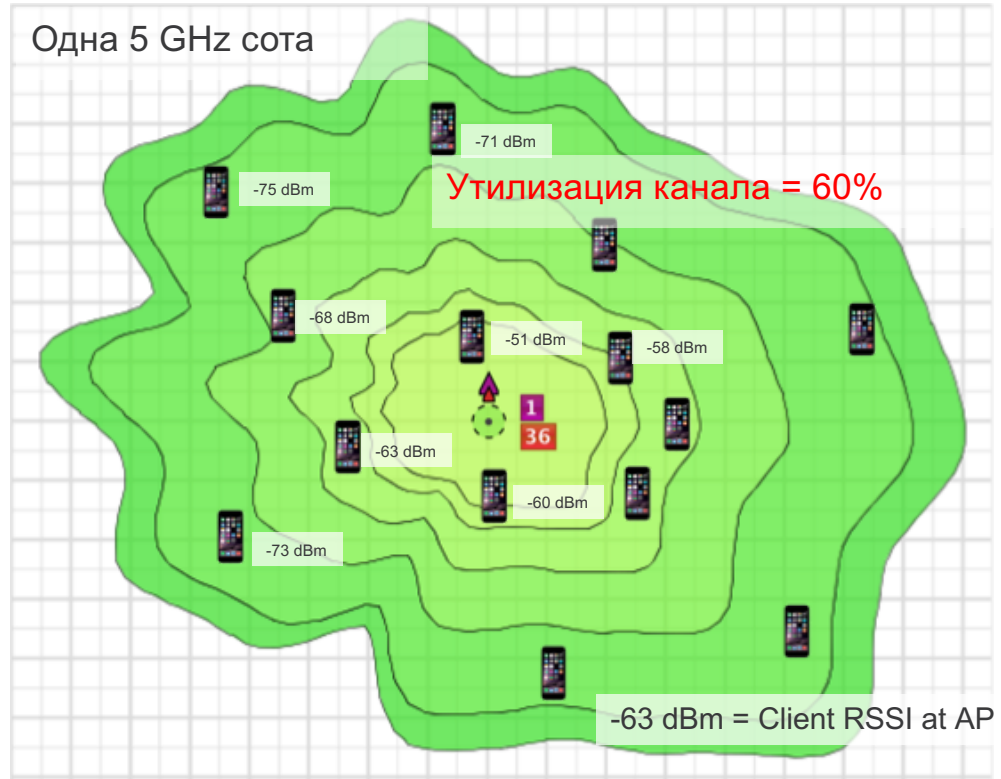

AP-4800 Antenna System Overview

Most Advanced Antenna System (25 Elements) in a Single Access Point

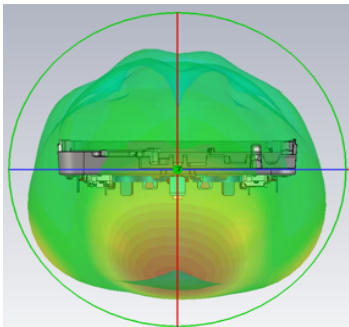

(4) 2.4/5GHz Macro Antenna Elements

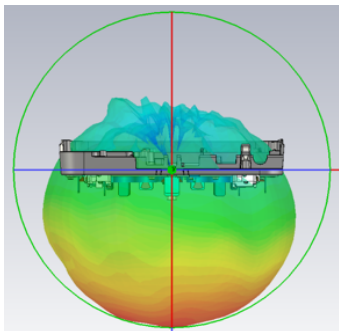

(4) 5GHz Micro Cell Antenna Elements

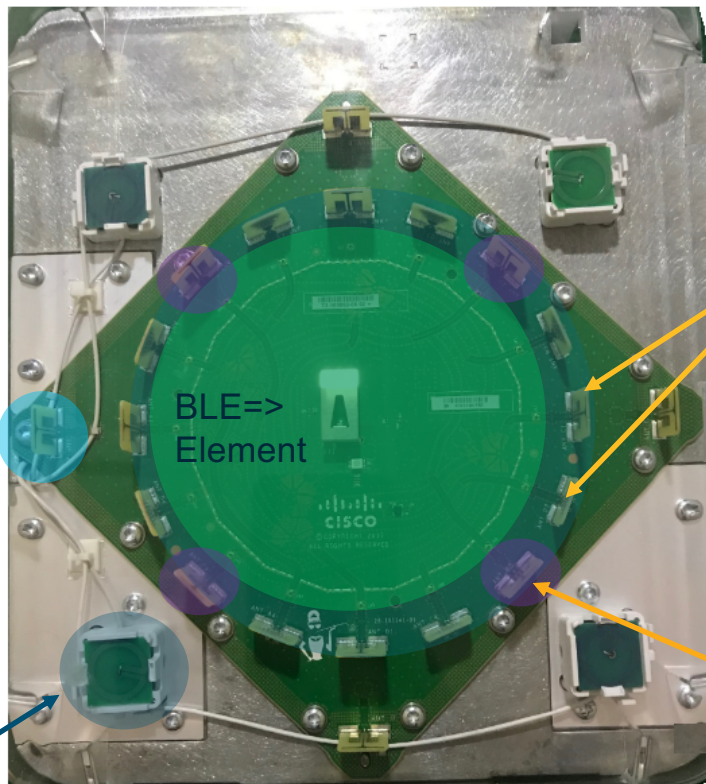

Total Antenna Elements = 25

(16) Element Directional Antenna Array (Digitally Switched) for Location tracking

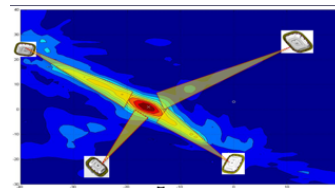

(4) Omni-Directional Elements (Digitally Switched) for 24x7 Monitoring & Analytics / DNA Assurance



AP-4800 Overview

AP-4800 is the next evolution of Cisco's Wave-2 Access Point, redefining RF Excellence

- In addition to all the features supported by the AP-3800i the new AP-4800 contains the following **new** components:
 - **Built-in Hyperlocation antenna Array**, 16 Element Antenna Array for Hyperlocation, and packet monitoring
 - **Analytics Capabilities** providing event driven real-time data captures. This provides Real-time visibility into DNAC and potential 3rd party analytics
 - **3rd Flexible (receive only radio)**, specifically for Analytics, Hyperlocation, Wireless Security Monitoring, and future functionality using the programmable digital antenna array.
 - **Built-in BLE Radio capable of BLE TX/RX**. This is similar to the BLE radio in the WSM module for the AP3700
 - **Hyperlocation AoA technology**, Location accuracy on Wi-Fi similar to the AP3700 + HL module
 - Full Flexible Radio Assignment Operating modes, such as Dual-5GHz while performing Hyperlocation
 - Note: Module port on AP3800 is not available on the AP-4800 (it is used internally for the Analytics Radio)
- **Code version supported below, will be introduced with a special version of 8.7**

WLC	Cisco Prime	CMX	DNA	ISE	SDA Mode	ME Mode
8.7.x	3.4	10.5	1.2	2.3 / 2.4	8.8	8.8

AP-4800 is a more advanced AP than the AP-3800

Similar to the AP-3800i but it has an additional Flexible Radio for Analytics + Advanced Hyperlocation antenna array

- Location Array antenna is now integrated
- Bluetooth Low Energy radio is now integrated
- Embedded analytics/location radio is now integrated

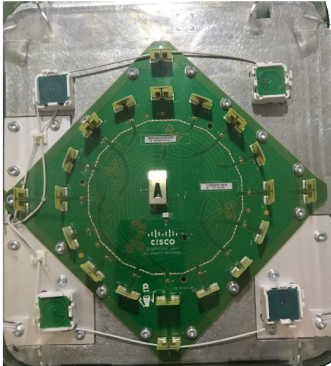

Hyperlocation
antenna array



DNA Analytics, Monitoring
and Location Radio



AP-4800
Best in Class

AP 4800 - Power Requirements

		Description	AP Functionality	PoE Budget @ PSE (Watts)	802.3af Or PWRINJ5	802.3at PoE+ PWRINJ6	802.3bt uPoE AIR-PWR50
4800	PoE 802.3at	4800 – Out of the Box (8.7.x.x)	Recommend: Disable USB & AUX port Limit mGig to 1 GbE	30W	X		
	PoE 802.3bt (uPoE)	4800 – Out of the Box (8.7.x.x)	All Features Enabled	32W	X	X	

DC Supply AIR-PWR-50 will draw 28.7W

AP4800 mounted on the ceiling



AP4800

Length 9.9" (251.46mm)
Width 8.68" (220.47mm)
Thickness 2.87" (72.9mm)
Weight 5.6 lbs (2.54 kilograms)

AP3800i

Length 8.66" (219.96mm)
Width 8.68" (220.47mm)
Thickness 2.46" (62.48mm)
Weight 4.6 lbs (2.09 kilograms)

4800 Timeline and Ordering Information

Limited-time: Aironet 4800, \$1795 when purchased with DNA-A or C1 DNA-A subscription*

April 16th - External Launch

Early June - FCS

May 16th - Orderability

Promo

Part Number	Description	US List Price
PROMO-AIR-AP4800-x-K9	Promotional: 802.11ac Wave-2 Analytics AP with Intelligent Capture and DNA-A License	\$1795 + DNA-A*
PROMO-AIR-AP4800-x-K9C	Promotional: 802.11ac Wave-2 Analytics AP with Intelligent Capture and DNA-A License (CFG)	\$1795 + DNA-A*
AIR-AP4800-x-K9	802.11ac Wave-2 Analytics AP with Intelligent Capture	\$1995 + DNA Attach
AIR-AP4800-x-K9C	802.11ac Wave-2 Analytics AP with Intelligent Capture	\$1995 + DNA Attach

Planned regulatory domains: A, B, C, D, E, F, G, H, I, K, N, Q, R, S, T, Z

Ecosystem Compatibility:

- AireOS 8.7.x
- DNAC 1.2.x
- CMX 10.5
- Prime Infrastructure 3.4

*pricing subject to change and expires 5/1/19

Радио инновации: Assurance и аналитика

Assurance: it's all about Insights...

DNA Wireless Assurance powered by Cisco Aironet



Active Sensor
Testing



Wi-Fi iOS
Analytics



Streaming
Telemetry



Network Time
Travel



Intelligent Capture
Auto PCAPs



Intelligent Capture
Forensics



Actionable
Insights

Guided
Remediation

Aironet Active Sensor
with proactive wireless
network test



DNA Solution

Cisco Enterprise Portfolio

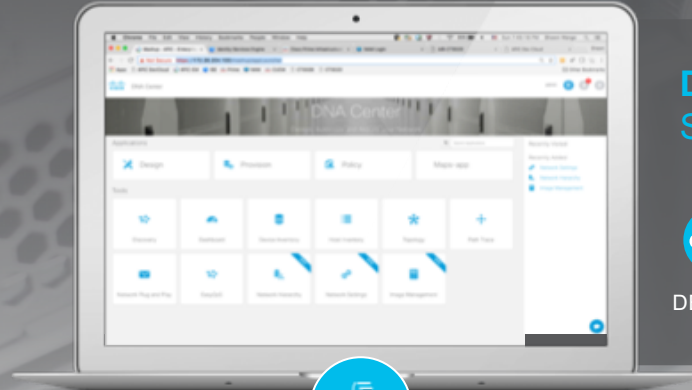

DNA Center Simple Workflows



DNA Center



Identity Services Engine

APIC-EM



Network Data Platform



Routers



Switches

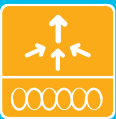

Wireless Controllers



Wireless APs

Аналитика iOS (расскажи мне о себе)



Партнерство Cisco-Apple для того, чтобы все работало как надо

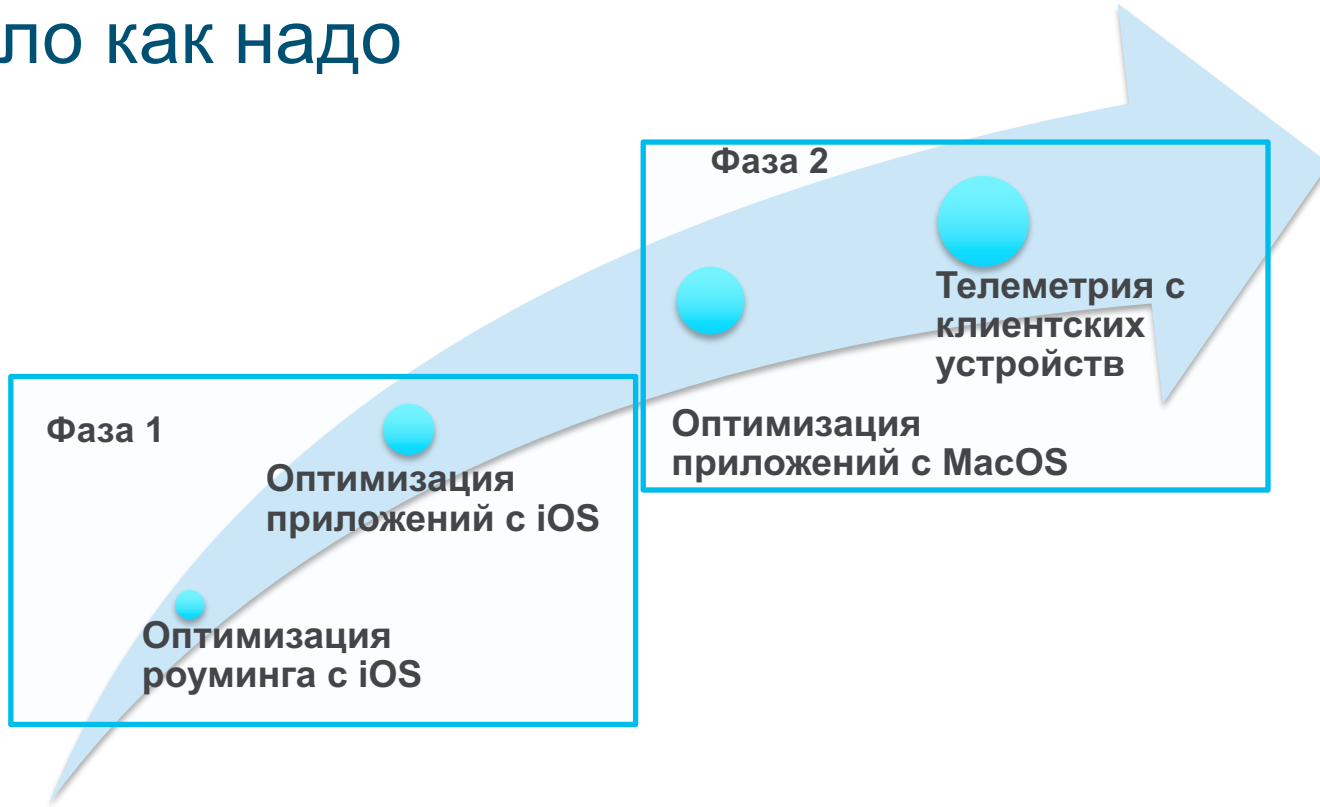

Cisco Apple Фаза 2 : iOS Analytics

1. Информация об окружающих клиента точках доступа, передаваемая клиентом инфраструктуре
2. Подробный отчет о причине отключения, передаваемая клиентом инфраструктуре
3. Информация о версии iOS и модели устройства, передаваемая клиентом инфраструктуре

[Видеодемонстрация: https://youtu.be/1XCqV0Pux_s](https://youtu.be/1XCqV0Pux_s)

Поддержка Cisco Apple Analytics (DNA Center не обязателен)

Device Type	iPhone	iPad
Device Hardware	iPhone 7 Internal Name: iPhone9,1 and iPhone9,3	iPad Pro (12.9-inch) Internal Name: iPad6,7 and iPad6,8
	iPhone 7 Plus Internal Name: iPhone9,2 and iPhone9,4	iPad Pro (9.7-inch) Internal Name: iPad6,3 and iPad6,4
	iPhone 8 Internal Name: iPhone10,1 and iPhone10,4	iPad Pro (12.9-inch, 2 nd gen) Internal Name: iPad7,1 and iPad7,2
	iPhone 8 Plus Internal Name: iPhone10,2 and iPhone10,5	iPad Pro (10.5-inch) Internal Name: iPad7,3 and iPad7,4
Apple iOS Software	11.0 and higher	11.0 and higher
Cisco AireOS Software	8.5+	8.5+
Access Point Support	802.11 ac APs	802.11 ac APs

Сеть «глазами» клиента

Как клиент «видит» сеть?

Инфраструктура не понимает, почему именно эту ТД выбрало для подключения клиентское устройство, потому что не может взглянуть на себя с его стороны

Почему это нужно?

Потому что без этой информации инфраструктура не сможет помочь этому (и другим) клиенту выбрать лучшую ТД

Как Cisco и Apple решили эту проблему?

Сразу после успешной генерации ключей в процессе ассоциации устройство с iOS 11 отправляет своей ТД 802.11k beacon report (режим Unsolicited)

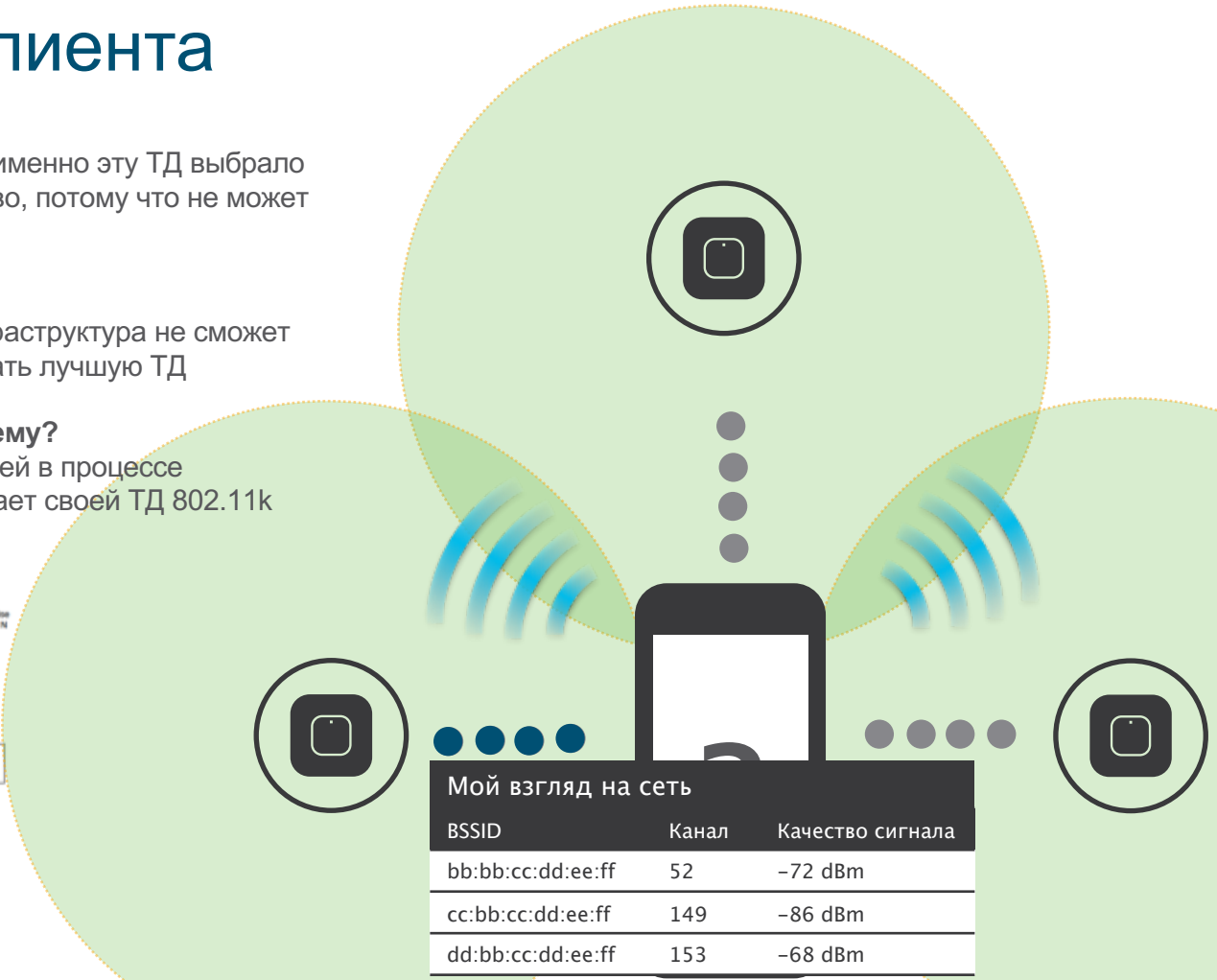
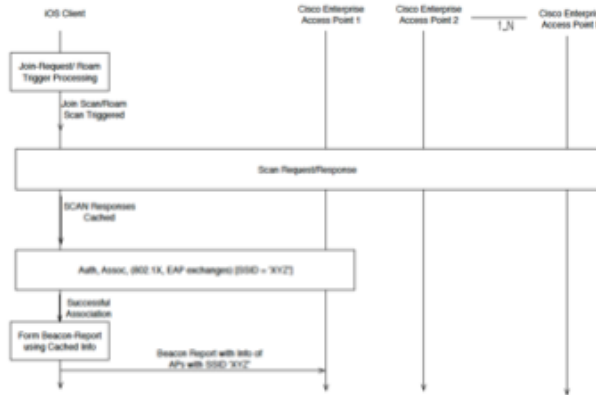

Мой взгляд на сеть

BSSID	Канал	Качество сигнала
bb:bb:cc:dd:ee:ff	52	-72 dBm
cc:bb:cc:dd:ee:ff	149	-86 dBm
dd:bb:cc:dd:ee:ff	153	-68 dBm

Cisco 5500 Series Wireless Controller

CLIENT VIEW

GENERAL

User Name: Unknown
Host Name: iPhoneSeven

MAC Address: 04:61:96:5a:af:0

Uptime: Associated since 1 Minute 47 Seconds

SSID: [ssid_1 (52-52)]

AP Name: [corona_1 (-62 dBm)] [2700(-70 dBm)]

Nearest APs: [corona_1 (-62 dBm)] [2700(-70 dBm)]

Device Type: iPhone9,1

OS Version: 11.0

Previous AP: 58:ac:75:af:84:20

Last disassociation reason: User triggered disassociation

Performance: Signal Strength: -60 dBm Signal Quality: 23 dB Connection Speed: 400 Mbps Channel Width: 40 MHz

Capabilities: 802.11ac (5GHz) Spatial Stream: 2

Cisco Compatible: Not Supported

Connection Score: 65%

CONNECTIVITY: Start -> Association -> Authentication -> DHCP -> Online

TOP APPLICATIONS

Rank	Name	Usage
1	ping	35.9 KB
2	apple-services	331.3 KB
3	dns	35.6 KB
4	icmp	59.4 KB
5	ispwd	42.2 KB
6	Rules	14.9 KB
7	all-web-services	12.8 KB
8	ntp	10.9 KB

CLIENT SCAN REPORT

Mac Address	RSSI	Channel
58 ac 75 af 84 20	-60	52
04 61 96 5a af 0	-60	52
04 61 96 5a 51 40	-60	52
04 61 96 5a 17 30	-60	52
04 61 96 5a 17 30	-60	52
58 ac 75 af 84 20	-60	52

Где можно увидеть эту информацию на контроллере?
На странице с детализированной информацией о конкретном клиенте

- Как мы можем ее использовать?
- Создать супер точные карты покрытия
 - Предоставлять другим клиентам релевантный neighbor list
 - Советовать оптимальную ТД для роуминга

Мой взгляд на сеть

BSSID	Канал	Качество сигнала
bb:bb:cc:dd:ee:ff	52	-72 dBm
cc:bb:cc:dd:ee:ff	149	-86 dBm
dd:bb:cc:dd:ee:ff	153	-68 dBm



Что сеть знает об устройстве

Что сеть знает об устройстве?

Производителя (OUI), иногда тип устройства (iPhone/iPAD) при использовании DHCP и HTTP профилирования

Когда этого недостаточно?

Когда есть подозрения в поведенческих различиях конкретных моделей/версий ОС

Как Cisco и Apple решают эту задачу?

Сразу после ассоциации клиент с iOS 11 и старше сам рассказывает о себе, позволяя с коррелировать поведение модель и версию ОС в различных областях пространства и в разные моменты времени

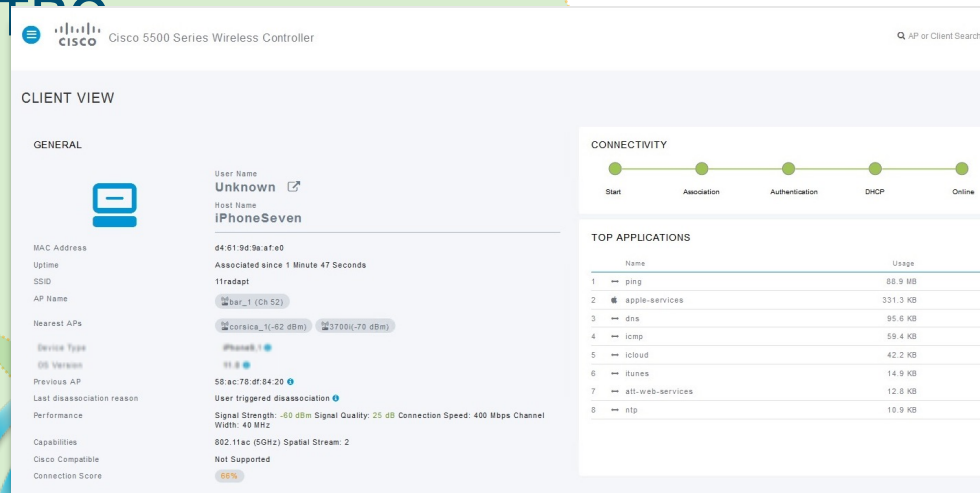

The screenshot shows the Cisco 5500 Series Wireless Controller interface. The main section is titled 'CLIENT VIEW' and contains a 'GENERAL' tab. The client information is as follows:

- User Name: Unknown
- Host Name: iPhoneSeven
- MAC Address: d4:61:9d:9a:af:e0
- Uptime: Associated since 1 Minute 47 Seconds
- SSID: 11radapt
- AP Name: bar_1 (Ch 52)
- Nearest APs: corsica_1(-62 dBm), 3700(-70 dBm)
- Device Type: iPhone7
- OS Version: 11.0
- Previous AP: 58:ac:78:df:84:20
- Last disassociation reason: User triggered disassociation
- Performance: Signal Strength: -60 dBm, Signal Quality: 25 dB, Connection Speed: 400 Mbps, Channel Width: 40 MHz
- Capabilities: 802.11ac (5GHz) Spatial Stream: 2
- Cisco Compatible: Not Supported
- Connection Score: 65%

On the right side, there is a 'CONNECTIVITY' diagram showing a sequence of steps: Start, Association, Authentication, DHCP, and Online. Below that is a 'TOP APPLICATIONS' table:

Name	Usage
1 ping	88.9 KB
2 apple-services	331.3 KB
3 dns	95.6 KB
4 icmp	59.4 KB
5 icloud	42.2 KB
6 itunes	14.9 KB
7 att-web-services	12.8 KB
8 ntp	10.9 KB



Коротко о себе

Я iPhone 7 с iOS 11.0

Где посмотреть эту информацию на контроллере?

Страницы Client Summary/Detailed

Почему клиентское устройство отключилось?

Знаем ли мы причину отключения клиента?
ТД не знает, по какой причине клиентское устройство приняло решение о роуминге или отключении ... плохой сигнал? Что-нибудь еще?

Почему это проблема?
Без данной информации поиск возможных неисправностей (плохая конфигурация, пробелы в покрытии и т.д.) может быть затруднен

Как Cisco и Apple решают эту проблему?
Устройство Apple отправляет инфраструктуре Cisco «секретный» код, соответствующий причине отключения

- Причины отключения**
- DHCP Failed
 - EAP Timed out
 - 802.1x Failed
 - Device Idle
 - Captive Portal security Failed
 - Decryption Failed
 - WiFi Interface Disabled
 - User-Triggered Disassoc
 - Peer-Triggered Disassoc
 - Beacon Loss

Вот почему я ушел
Reason Code



Почему клиентское устройство отключилось?

Где можно посмотреть Reason code на контроллере?
Страница Client detail

Как можно использовать данную информацию?

- Быстро обнаружить и локализовать проблему с покрытием
- Собрать данные для анализа поведения клиентов (где перемещаются клиенты, почему отключаются и т.д.)

The screenshot shows the Cisco 5500 Series Wireless Controller interface. The main section is titled 'CLIENT VIEW' and contains a 'GENERAL' tab. The client information includes:

- User Name: Unknown
- Host Name: iPhoneSeven
- MAC Address: d4-61-9d-9a-af-e0
- Uptime: 11radapt
- SSID: bar_1 (Ch 52)
- AP Name: corsica_1 (-62 dbm) and 3700(-78 dbm)
- Device Type: iPhone9,1
- OS Version: 11.0
- Previous AP: 88 ac 75 af 04 20
- Last disassociation reason: User triggered disassociation
- Performance: Signal Strength: -60 dbm, Signal Quality: 25 dB, Connection Speed: 400 Mbps, Channel Width: 40 MHz
- Capabilities: 802.11ac (5GHz) Spatial Stream: 2
- Cisco Compatible: Not Supported
- Connection Score: 66%

On the right side, there is a 'CONNECTIVITY' section with a progress bar showing the sequence: Start -> Association -> Authentication -> DHCP -> Online. Below that is a 'TOP APPLICATIONS' table:

Name	Usage
ping	88.9 MB
apple-services	331.3 KB
dns	95.6 KB
icmp	59.4 KB
icloud	42.2 KB
itunes	14.9 KB
atl-web-services	12.8 KB
ntp	10.9 KB



Впервые нам доступна информация о том, как iPhone или iPad “видит” беспроводную сеть

Monitoring
Network Summary
Access Points
Clients
Rogues
Access Points
Clients
Interferers
Wireless Dashboard
AP Performance
Client Performance
Best Practices

Cisco 5500 Series Wireless Controller

AP or Client Search | Advanced | [Email] [Settings]

CLIENT VIEW

GENERAL

User Name: **wifi-user**
Host Name: **iPhoneSeven**

MAC Address: d4:61:9d:9a:af:e0
Uptime: Associated since 13 Minutes 12 Seconds
SSID: 11radapt1x
AP Name: 11radapt1x (Ch 36)
Nearest APs: corsica_1(-55 dBm), 11radapt1x(-55 dBm), 11radapt1x(-55 dBm), 11radapt1x(-55 dBm), 11radapt1x(-55 dBm)
Device Type: iPhone 7
OS Version: 11.0
Previous AP: 58:ac:78:df:84:20
Last disassociation reason: Proprietary failure
Performance: Signal Strength: -57 dBm Signal Quality: 31 dB Connection Speed: 11 Mbps Channel Width: 40 MHz
Capabilities: 802.11ac (5GHz) Spatial Stream: 2
Cisco Compatible: Not Supported
Connection Score: 60%

CONNECTIVITY

Start — Association — Authentication — DHCP — Online

TOP APPLICATIONS

Name	Usage	% Usage
ping	56.4 MB	99.74%
apple-services	76.0 KB	0.13%
icmp	27.8 KB	0.05%
dns	27.5 KB	0.05%
ntp	7.3 KB	0.01%
atf-web-services	5.7 KB	0.01%
itunes	4.5 KB	0.01%
icloud	1.1 KB	0%

CLIENT SCAN REPORT

Mac Address	RSSI	Channel
d8:b1:90:4a:51:e2	-63	38
58:ac:78:df:84:22	-75	38
a0:ec:f9:6d:17:82	-80	38

Annotations:
- Соседние ТД (Adjacent TD)
- Тип и ОС клиента (Client type and OS)
- Предыдущая ТД (Previous TD)
- Причина отключения от предыдущей ТД (Reason for disconnection from previous TD)
- Клиентский «взгляд» на сеть (Client's view of the network)

DNA Center Client 360°

1. Client profile – Версия OS и модель устройства

Detail Information

Device RF iOS Analytics

Information	Connective Information
User Name: gmf	Band: 2.4 GHz
Host Name: iPhone-7	Spatial Streams: 2
MAC Address: 64:8D:AE:11:12:93	Channel Width: 20 MHz
IP Address: 192.168.88.255	WMM: SUPPORTED
Device Type: iPhone6,1	Q-AMSD: DISABLED
Operating System: iOS11.0	

2. Информация о соседских ТД

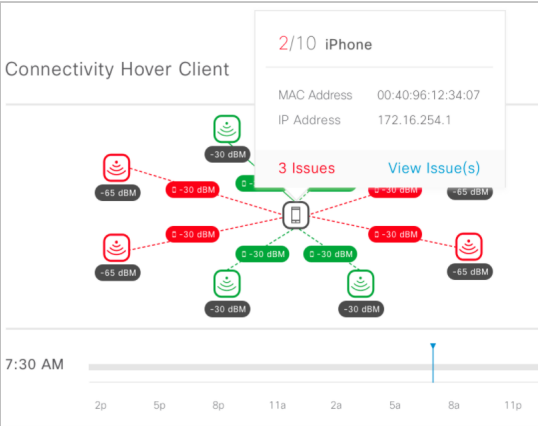

3. Предыдущие ТД и причины отключения от них

Disassociation Events

Filter EQ Find

Disassociation Reason	Disassociated from AP	Time	Location Building
cL_ST_USER_TRIGGERED	LA1-AP3802-31	Sun Oct 22 2017 21:47:01 GMT-0700 (Pacific Standard Time)	Los Angeles
cL_ST_USER_TRIGGERED	LA1-AP3802-31	Sun Oct 22 2017 21:28:01 GMT-0700 (Pacific Standard Time)	Los Angeles
cL_ST_DEVICE_IDLE	LA1-AP3802-31	Sun Oct 22 2017 21:33:01 GMT-0700 (Pacific Standard Time)	Los Angeles
cL_ST_DEVICE_IDLE	LA1-AP3802-31	Sun Oct 22 2017 21:19:01 GMT-0700 (Pacific Standard Time)	Los Angeles
cL_ST_DEVICE_IDLE	LA1-AP3802-31	Sun Oct 22 2017 21:11:01 GMT-0700 (Pacific Standard Time)	Los Angeles

DNA-C Assurance и аналитика Apple

1

Информация об устройстве

- Клиент говорит о себе
1. iPhone 7, iPad Pro
 2. iOS 11

Позволяет делать выводы, учитывая точные модели устройств и их ОС

2

Wi-Fi Аналитика

- Клиент делится своим «взглядом» на сеть
1. BSSID
 2. RSSI
 3. Канал

Анализ покрытия

3

Assurance

- Предыдущая ТД и причина отключения от нее

То, что клиентам не нравится

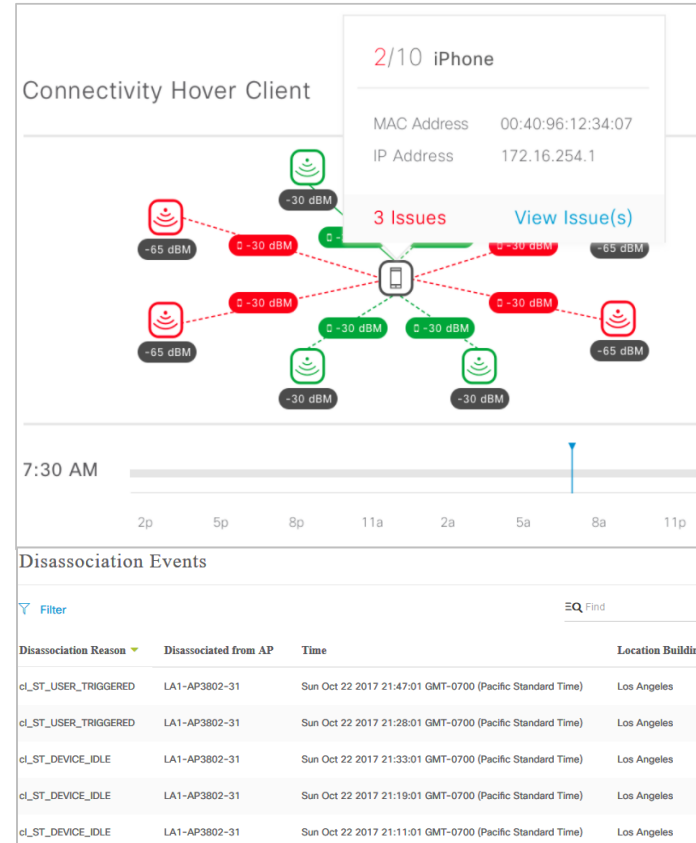

DNAC Client 360°

Detail Information

Device Info RF **IOS Analytics**

Neighbor APs (3)

Export

Filter

BSSID	AP Name	Channel	RSSI (dBm)	Location Building Fir
A0:F8:49:7E:C0:4F	LA1-AP1815-32	48	-84	Global/USA/LA/LA-Level16
38:90:A5:CD:69:6F	LA1-AP3802-31	36	-51	Global/USA/LA/LA-Level16
38:90:A5:82:1F:A0	LA1-AP2802-38	1	-21	Global/USA/LA/LA-Level16

Show 10 entries

Showing 1 - 3 of 3

Previous 1 Next

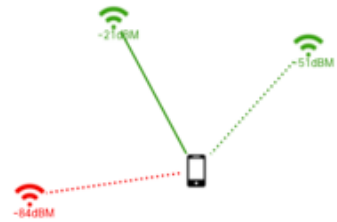

Client Disassociation Details (144)

Export

Filter

Time	Disassociation Reason	Disassociated AP	Session Duration	AP Location
Wednesday, January 10, 2018 9:47 PM	User triggered disassociation	LA1-AP3802-31		LA-Level16
Wednesday, January 10, 2018 9:33 PM	Device Idle	LA1-AP3802-31		LA-Level16
Wednesday, January 10, 2018 9:28 PM	User triggered disassociation	LA1-AP3802-31		LA-Level16
Wednesday, January 10, 2018 9:19 PM	Device Idle	LA1-AP3802-31		LA-Level16
Wednesday, January 10, 2018 9:11 PM	Device Idle	LA1-AP3802-31		LA-Level16
Wednesday, January 10, 2018 9:06 PM	User triggered disassociation	LA1-AP3802-31		LA-Level16
Wednesday, January 10, 2018 8:47 PM	User triggered disassociation	LA1-AP3802-31		LA-Level16
Wednesday, January 10, 2018 8:33 PM	Device Idle	LA1-AP3802-31		LA-Level16
Wednesday, January 10, 2018 8:28 PM	User triggered disassociation	LA1-AP3802-31		LA-Level16

Wireless Client and Network Health

Streaming Telemetry

A decorative graphic at the bottom of the slide. It features a large, solid red circle centered on a light cyan background. The cyan background is split into two vertical sections by the red circle, with the left section being a lighter shade of cyan and the right section being a slightly darker shade.

Streaming Telemetry vs. SNMP/Legacy Polling

Traditional Telemetry

SNMP / Legacy data
pull methods

Streaming Telemetry

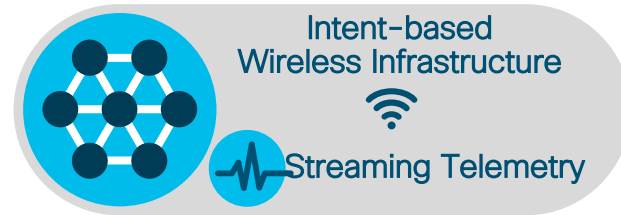

Pull based data import

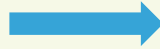

Push based data export

CPU overhead with data crawlers

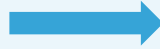

Low CPU overhead

Data intensive without optimizations

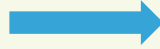

Optimized for Data export (KPI, Events)

No real time notification and false alarms



Notification send seconds after change

Min polling has too many black holes



Reduced delay in management data

Making Aironet Infrastructure open and programmable for best in-class Analytics

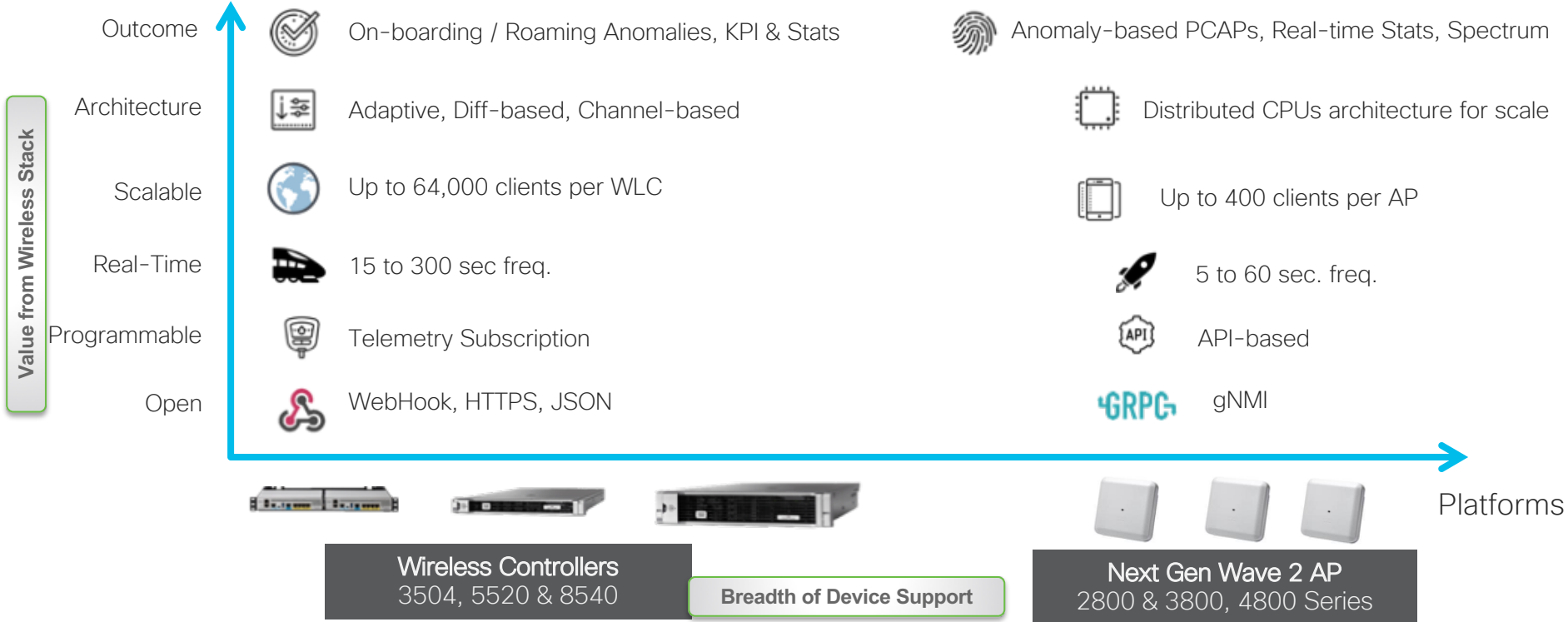

Overall Health Summary View

- Geo map with sites or Hierarchical Site View to show the site health score
- Client Health Score and Network Health Score summary
- Recent Top 10 Global Issues

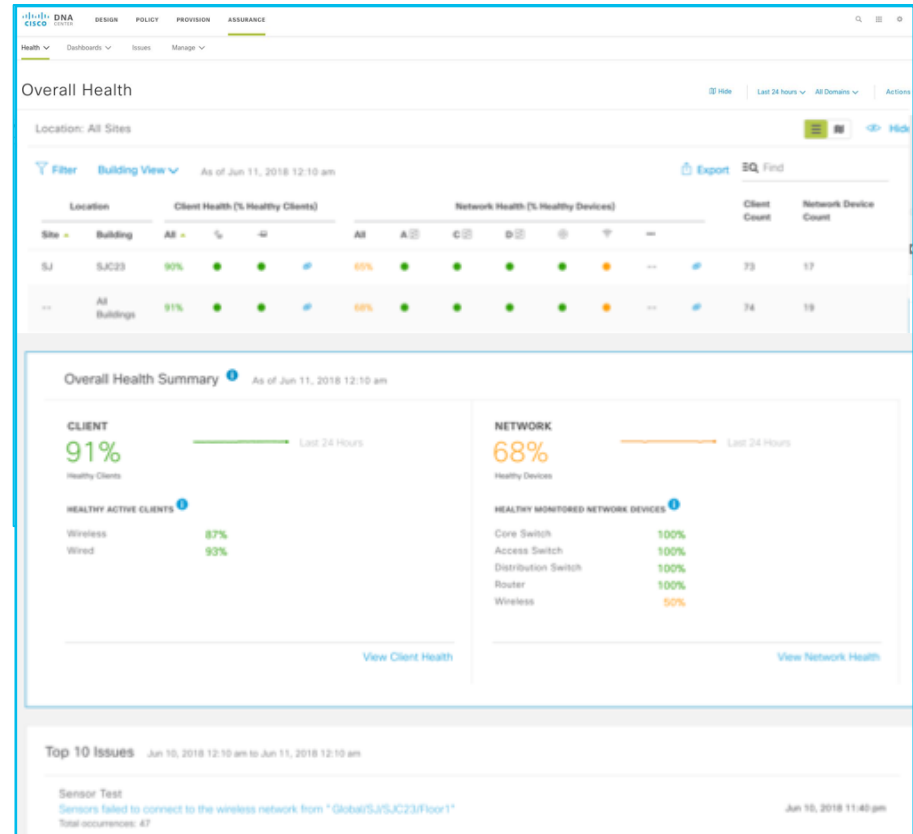

Enhanced Client Health

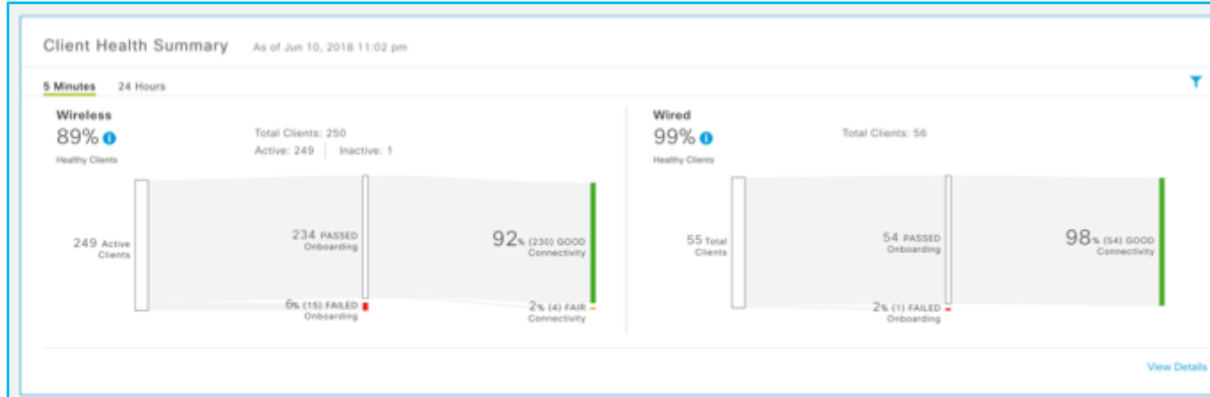

- 5 Minutes View for current snapshot
- Total to Onboard Success/Failed Client to Connected Health Score

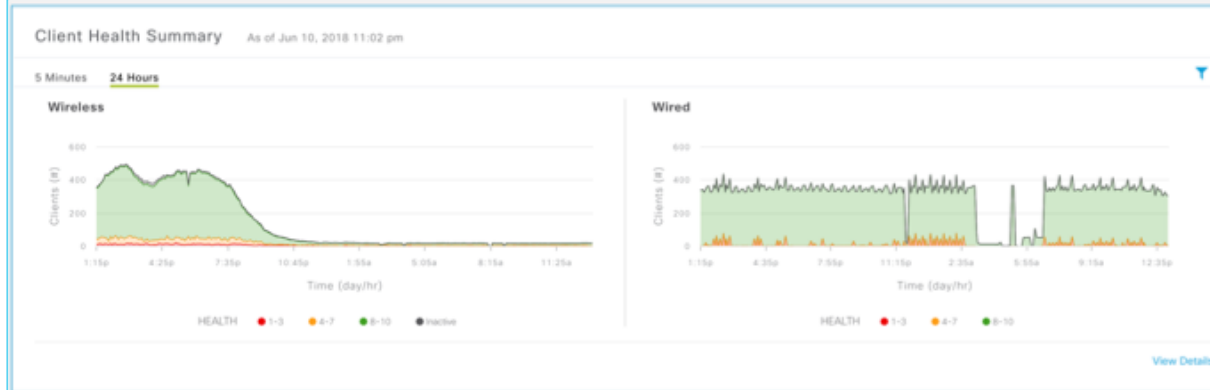

- 24 Hours view for Daily Trending

Client Health Score Details – Wireless Client

- Health Score = Single KPI that indicate client connection status & quality
- Calculated per every 5 min, using client KPIs from WLC streaming telemetry arrives in 30-90 sec. interval. Use Weighted Average

Onboarding Score by status:

- 1 – Red (Not onboarded)
- 4 – Green (Onboarded)



Connected Health Score from Weighted Average of Client RSSI & SNR

- 0 to 6 based on RSSI/SNR Range

RSSI	≤ -72 dBm	-71 dBm	-70 dBm	-69 dBm	-68 ~ -56 dBm	-55 ~ -46 dBm	≥ -45 dBm
SNR	0 ~ 9	10	11 ~ 12	13 ~ 14	15 ~ 19	20 ~ 39	≥ 40
Connected Health Score	0	1	2	3	4	5	6

Client Health Analytics Charts – Last 30min

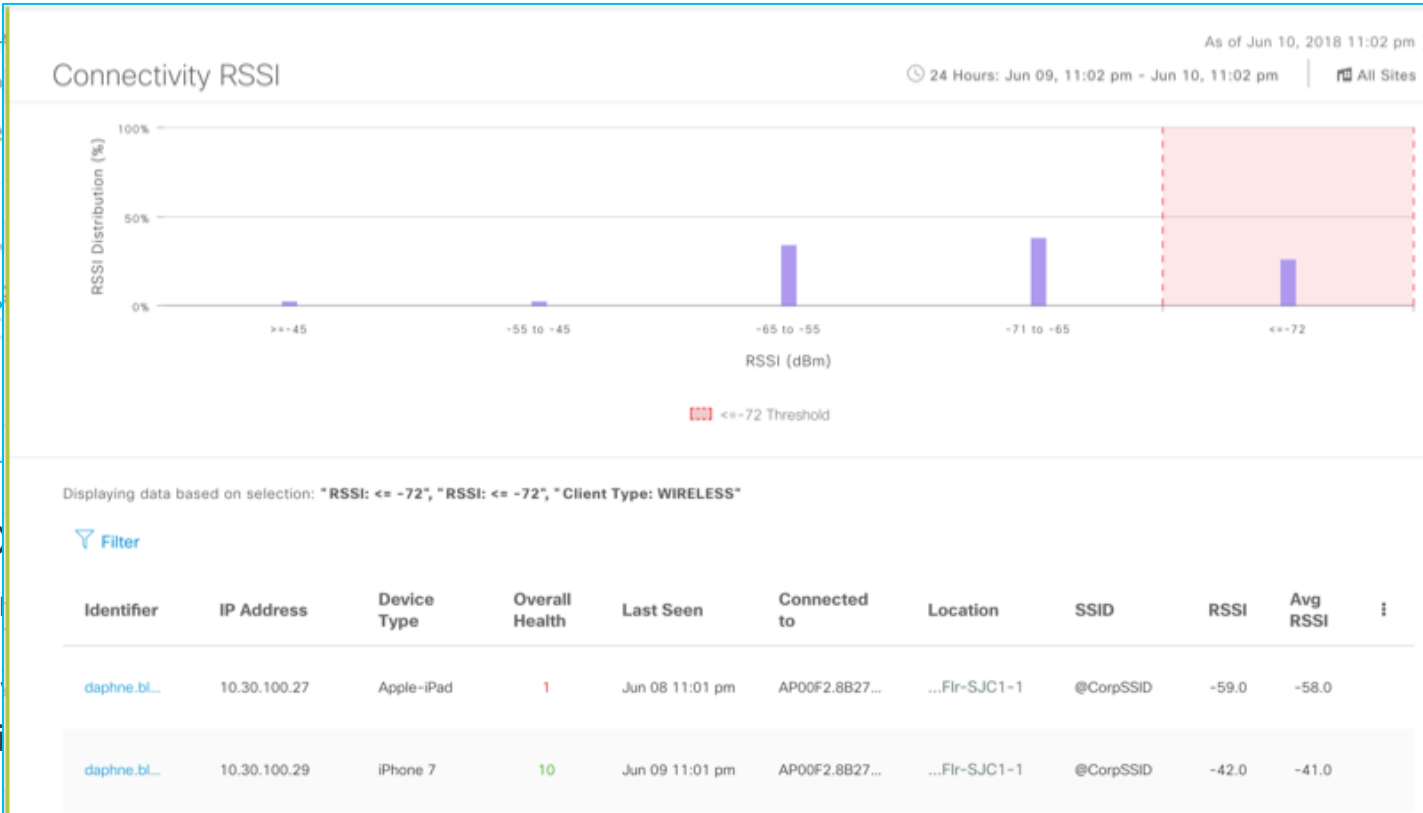
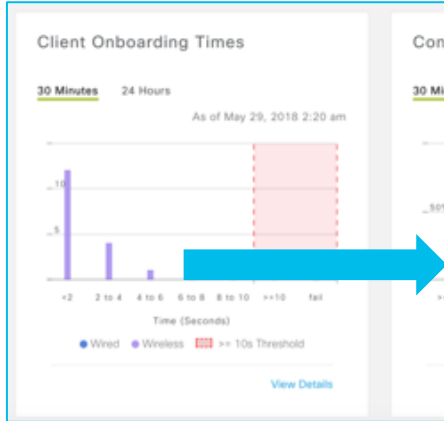

- Client Attempts by C
- Distribution of total o
- Connectivity RSSI /
- RSSI / SNR distributi

Client Health Analytics Charts – 24 hours

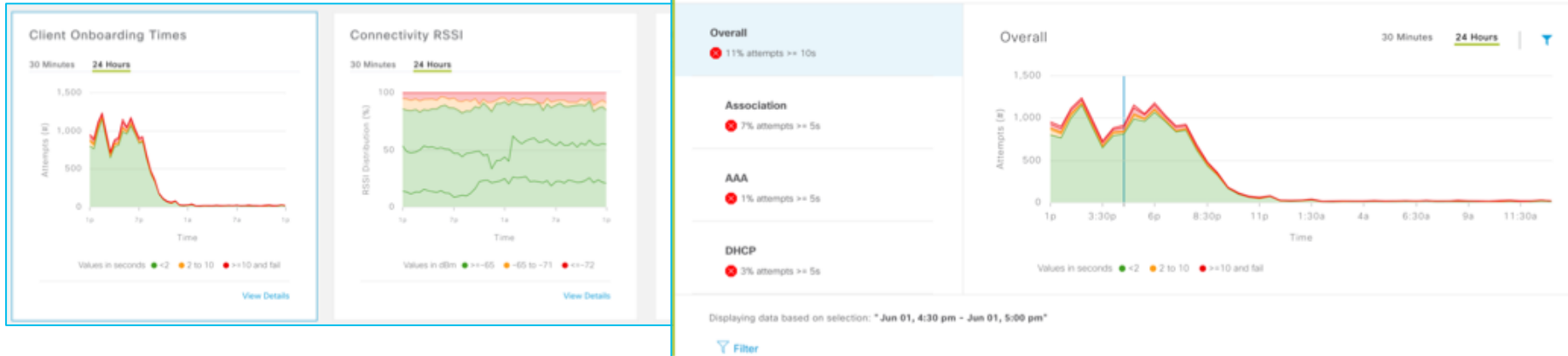

- Last 24 Hours Trends of Onboarding Times, Connectivity RSSI and Connectivity SNR Trend
- View Details will provide access to historical client views

Client Health Drill Down – OnBoarding

- Break down view of Assoc. time, AAA time, DHCP time,
- Per Server View on AAA & DHCP
- Select any sub-section will show client lists in selected category
- Display Applied Filter on top of list
- Show Onboarding performance of each client

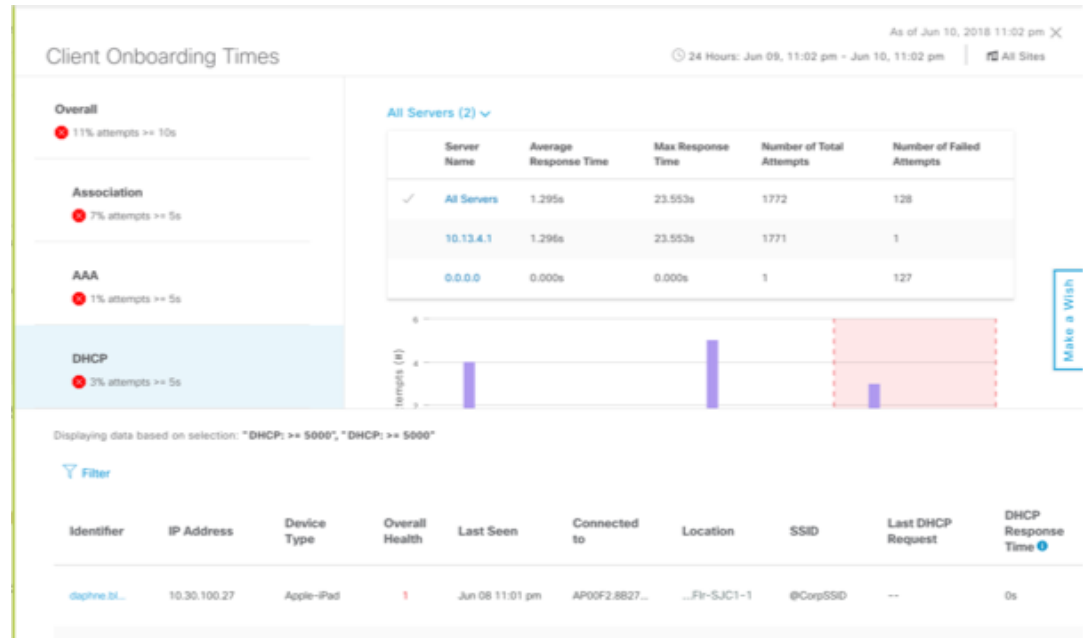

Client 360

- Shows Details on specific client
- Timeseries metric chart of the client health score
- Individual Client issues
- Onboarding Event Viewer
- Application Experience
- Using WLC – Usage, Throughput, DSCP QoS Tag
- Using Router – App Health derived from Network Delay, App Delay, Packet Loss
- Path Trace Tool for Troubleshooting
- Connection Details



Application Experience *BETA* As of Jun 10, 2018 11:43 am Refresh

Business Relevant Business Irrelevant Default

Application (4) Export

Filter SQL Find

Name	Host Name	Health		Usage		Average Throughput	Traffic Class	DSCP		Packet Loss (%)	
		Most Recent	Last 24 Hours	Bytes	Percentage (%)			Marking	Preservation	Max	Avera
oifs	--	1	View	29.53 GB	4	2.86 Mbps	bulk-data	DF	No	72	0.1
outlook-web-service	outlook.live.com	5	View	35.45 MB	0	2.81 Kbps	bulk-data	DF	No	11	
mp	--	--	--	29.69 KB	0	17 bps	app-admin-mgmt	DF	No	--	
dns	--	--	--	551 B	0	7 bps	app-admin-mgmt	DF	No	--	

Client 360 – Event Viewer

The screenshot displays the Cisco DNA Center Event Viewer interface. The top navigation bar includes 'DESIGN', 'POLICY', 'PROVISION', and 'ASSURANCE'. The 'Event Viewer' section is active, showing a list of events for May 21, 2018. A 'Delete' event is selected, and its details are shown on the right.

Event Type	Event Description	Timestamp
Client Deauthenticated	DHCP Invalid interface group	11:35:05.727 AM
Deleted		11:35:05.727 AM
DHCP	DHCP Discover	11:34:45.238 AM
KeyExchange		11:34:40.147 AM
Mobility	MM Handoff Timeout	11:34:40.147 AM
Authentication Done	Dot1x Full Auth	11:34:40.136 AM
Authentication Start		11:34:40.058 AM
Association Done		11:34:40.056 AM

Delete (May 21, 2018 11:35:05 AM)

Status: Failure

Details:

VLAN	10
ROLE	LOCAL
AP_Mac	70-69-5A-38-27-20
AP_Name	AP4800-3
WLC_Name	WLC
IPv4	0.0.0.0
WLAN	@NoIPAddress
DHCP-Server	10.10.1.1
USERNAME	Vendor

- Detailed record of Client Onboarding State machine
- Always On for All of Clients
- Highlight any Onboarding Failure, Roaming Failure, Deauthentication from AP or Client
- Each Events are aggregated per onboarding session, provide session details
- Provide Onboarding delay and duration per each step
- Store up to 14 Days works with Network Time Travel feature

Network Health Table

Predefined filters
for Type and
Health

Additional
Filters

Network Devices (18) As of Jun 11, 2018 12:35 am

DEVICE Monitored Unmonitored TYPE All Access Core Distribution Router Wireless OVERALL HEALTH All Poor Fair Good Export

[Filter](#)

Device	Device Type	IP Address	OS Version	Overall Health Score 1	System Health 1	Data Plane Connectivity 1	Control Plane Connectivity 1	Issue Count	Location	
AP2800	AIR-AP2802I-B-K9	10.13.1.15	8.5.130.0	1	●	●	●	-	SJ/SJC23/Floor1	
AP3800-4	AIR-AP3802I-B-K9	10.13.1.207	8.5.130.0	6	●	●	●	-	SJ/SJC23/Floor1	
AP3800-3	AIR-AP3802I-B-K9	10.13.1.206	8.5.130.0	6	●	●	●	-	SJ/SJC23/Floor1	

Exportable to CSV

- Table of Devices in the Global and Site context

Network Health Drill Down

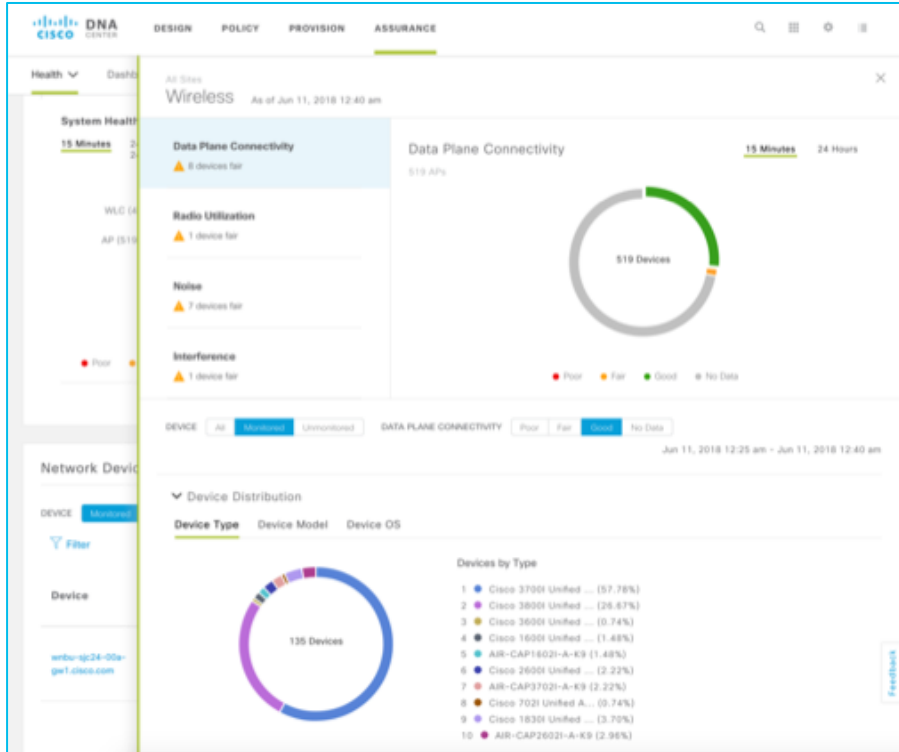

- Drill down to view breakdown of the health by KPI type
- Metrics listed per category and the threshold values
- Device Distribution Chart upon selecting Network Health Score range
- Workflow to identify the actual devices having a bad score

Беспроводные активные сенсоры

Проактивное устранение неполадок с перспективы беспроводного клиента



Sensor Anywhere Drives Intelligence of DNA Assurance to the edge

Test Your Network Anywhere at Any time at Real-world Client Level

Aironet 1800S Active Sensor



- 2x2 with 2 spatial streams
- **Multiple powering options**
 - PoE Power
 - USB Type "C" power
 - Direct AC Power Plug
- Integrated BLE
- Ultra compact form factor

AP as a Sensor (1800/2800/3800/4800)



Purpose-built Hardware for Analytics

In-line monitoring to DNA for analytics and insights while serving clients



SLA Dashboard

Onboarding &
Services Tests

Configure Tests
Remotely

Global Issue
Creation

Dynamic Sensor
Test Trigger

Active Sensors test and provide client perspective to ensure Wireless Service readiness

Onboarding Tests

- 802.11 Association
- 802.11 Authentication & Key Exchange
- IP Addressing DHCP
- EAP-TLS
- WebAuth capture and redirect

App Connectivity

- Email: POP3, IMAP, Outlook Web Access
- File Transfer: FTP
- Web: HTTP

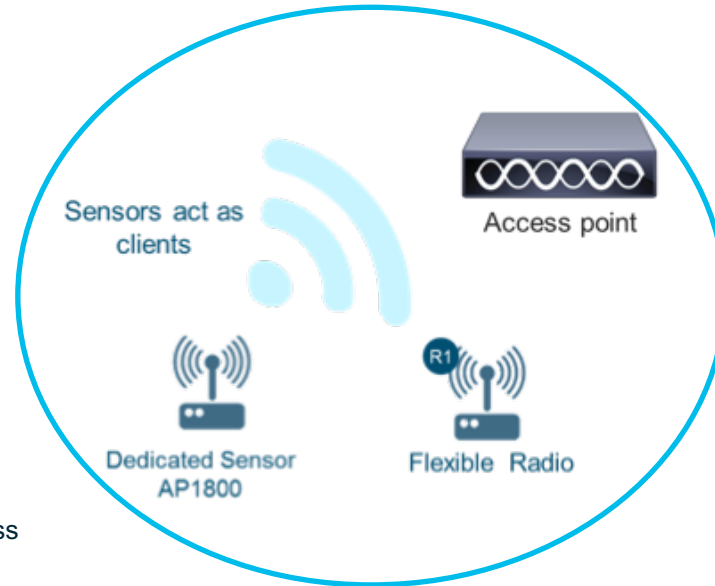

Network Services

- DNS
- RADIUS
- First Hop Router/Default gateway
- IPv6 Host Connectivity

App Performance*

- Packet Loss
- Jitter
- Latency
- Speedtest

Cisco Aironet 1800s Wireless Network Sensor



Cisco Aironet® 1800 Series

AIR-AP1800S-X-K9

- Full DNA Assurance Sensor Support
- 2x2 with 2 spatial streams
- 802.11ac Wave 2
- Multiple powering options:
 - PoE Power
 - USB Type “C” power
 - Direct AC Power Plug
- Integrated BLE*
- Small form-factor(WxLxH) :
 - 3.25” x 4.75” x 0.75”

*Post FCS

AP1800s inside view (backside)

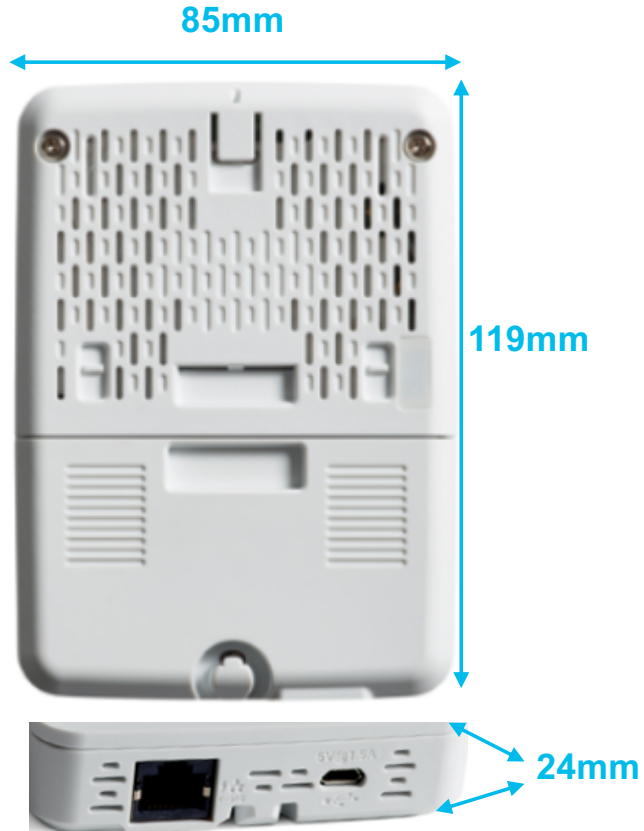

Powering Options



Two types of Sensor, Two types of discovery path to DNAC

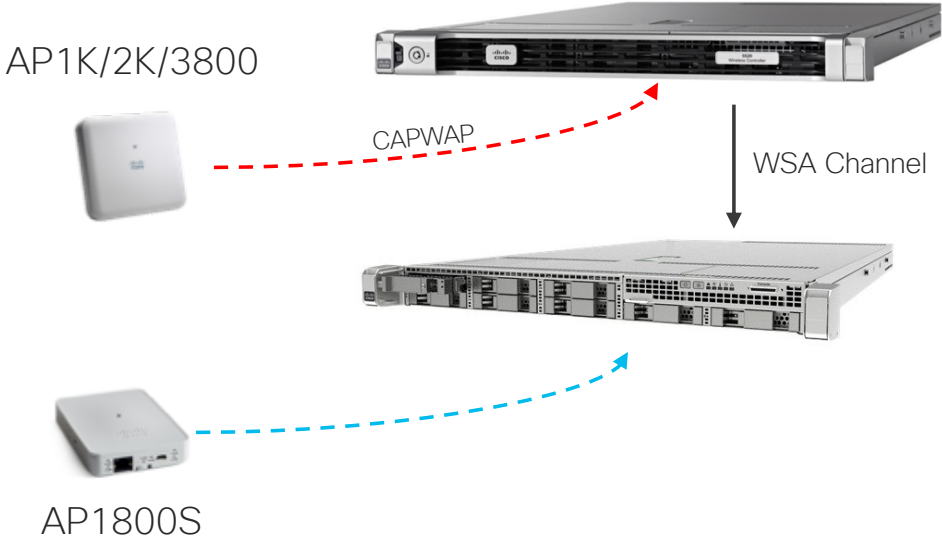

Schedule Sensor Testing: Step1

Create Sensor-Driven Test

[ASSURANCE] [Manage][Sensor-Driven Tests]

Step1. Create Sensor-Driven Test

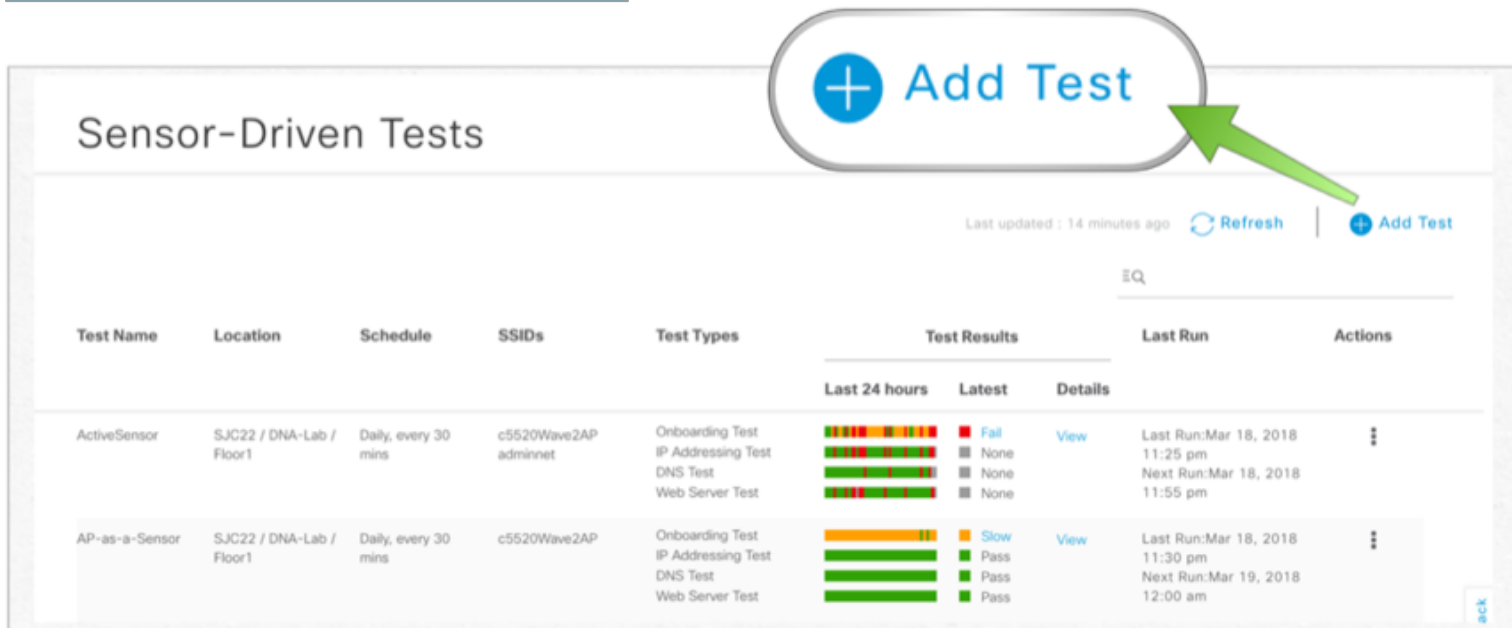

Sensor-Driven Tests

Last updated : 14 minutes ago [Refresh](#) | [+ Add Test](#)

EQ

Test Name	Location	Schedule	SSIDs	Test Types	Test Results			Last Run	Actions
					Last 24 hours	Latest	Details		
ActiveSensor	SJC22 / DNA-Lab / Floor1	Daily, every 30 mins	c5520Wave2AP adminnet	Onboarding Test			View	Last Run:Mar 18, 2018 11:25 pm Next Run:Mar 18, 2018 11:55 pm	⋮
				IP Addressing Test					
				DNS Test					
				Web Server Test					
AP-as-a-Sensor	SJC22 / DNA-Lab / Floor1	Daily, every 30 mins	c5520Wave2AP	Onboarding Test			View	Last Run:Mar 18, 2018 11:30 pm Next Run:Mar 19, 2018 12:00 am	⋮
				IP Addressing Test					
				DNS Test					
				Web Server Test					

Schedule Sensor Testing: Step1

Create Sensor-Driven Test

Step2. Add Test – Schedule, SSID selection



DESIGN POLICY PROVISION ASSURANCE



SENSOR-DRIVEN TESTS

Add Test

- 1 Schedule Tests
- 2 Select Tests
- 3 Select Sensors

Test Name: AP as a Sensor
Location: SJC22 / DNA-Lab... / Floor1
Interval-Hours: Every 1 Hours

(Select "Radios To Test" to add to test)

SSID	Radios To Test	Security	Credentials
c5520-Wave1-AP	<input type="checkbox"/> 2.4 GHz <input checked="" type="checkbox"/> 5 GHz	WPA2_PSK	Passphrase

Feedback

Cancel

Previous

Next

Schedule Sensor Testing: Step2

Select tests and Assign Sensor

Step3. Select Tests



DESIGN POLICY PROVISION ASSURANCE



SENSOR-DRIVEN TESTS

Add Test

- Schedule Tests
- Select Tests**
- Select Sensors

Test Name	Location	Interval-Hours
<input type="text" value="AP as a Sensor"/>	<input type="text" value="SJC22 / DNA-Lab... / Floor1"/>	<input type="text" value="Every 1 Hours"/>

Network Tests

IP Addressing Tests

DHCP

DNS Tests

DNS

Hostname to resolve

Host Reachability Tests

User Defined Host

Internal IP Address

External IP Address

Application Tests

Email Tests

POP3

Enter POP3 Server



IMAP

Enter IMAP Server



Outlook Web Access

URL

User Name

Feedback

Cancel

Previous

Next

Select tests and Assign Sensor

Step 4.
Select Test Sensor

Sensor – Target AP Threshold
RSSI Threshold: -35 ~ -90 dBm
Target AP # : 1 ~ 5

The screenshot displays the Cisco DNA Assurance interface. At the top, the navigation bar includes 'DNA CENTER' and tabs for 'DESIGN', 'POLICY', 'PROVISION', and 'ASSURANCE'. The main content area is titled 'Sensor Coverage' and shows a floor plan with a color-coded signal strength overlay. A vertical legend on the left indicates signal strength from -35 dBm (red) to -90 dBm (purple). Several APs are labeled on the map, including AP3600D, AP-D0, AP2800, AP3800-1, AP3700B, AP3700A, and AP3700C. A 'Sensor Selection' panel is open, showing a 'Set Thresholds' dialog box with a red dashed border. This dialog box contains a slider for 'RSSI Threshold' set to -75 dBm and a dropdown for 'Number of Target APs' set to 5. An 'Apply' button is visible below the settings. To the right of the dialog box is a table with columns for 'MAC Address', 'Client Count', 'Neighbor Count', and 'AP Count'. The table lists several MAC addresses and their corresponding counts. At the bottom of the interface, there are 'Cancel', 'Previous', and 'Save' buttons.

MAC Address	Client Count	Neighbor Count	AP Count
DC:CE:C1:2E:BD:C0	0	0	
00:81:C4:0D:8A:70	3	6	
00:81:C4:CD:AB:90	0	6	
00:62:EC:F3:55:90	0	6	

Sensor Test Failure generates global Issue when more than 2 sensor test failed per floor

The screenshot displays the Cisco DNA Center interface. The top navigation bar includes 'Health' and 'Dashboard'. The main content area is titled 'Issues' and shows a list of four issues. The first issue is highlighted, and a detailed view is shown on the right. The detailed view includes a description of the issue and a table of sensor test results.

Issues

Last 7 days | All Domains | View Issue Catalog

Open | Resolved

Last Occurred Time	Title	Total Occurrences	Category	Device
Feb 12, 2018 1:40 pm	Sensors failed to connect to the wireless network from "Global/SJC22/DNA-Lab/Floor1"	1	Sensor Test	Sensor
Feb 12, 2018 1:40 pm	Sensor is reporting wireless status failed from "Global/SJC22/DNA-Lab/Floor1"	-	-	-
Feb 12, 2018 1:40 pm	No response from local gateway from "Global/SJC22/DNA-Lab/Floor1"	-	-	-
Feb 12, 2018 1:40 pm	Failed to get an IPv4 address from "Global/SJC22/DNA-Lab/Floor1"	-	-	-

Showing 4 of 4

Sensors failed to connect to the wireless network from "Global/SJC22/DNA-Lab/Floor1"

Status: Open | Last Occurred: Feb 12, 2018 1:40 PM

Description
2 sensors from "Global/SJC22/DNA-Lab/Floor1" have failed to connect to the wireless network.

Sensor Issues Table

Mac Address	Test Suite	Band	IPURL	AP List
d0:ce:c1:2e:bd:c0	5a7f4ccca9bbd40205423ef	5 GHz	---	58:38:61:5f:94:c4
d0:ce:c1:2e:bd:c0	5a7f4ccca9bbd40205423ef	5 GHz	---	00:01:c4:0d:8a:7f
d0:ce:c1:2e:bd:c0	5a7f4ccca9bbd40205423ef	5 GHz	---	58:38:61:5f:cc:3f

New Sensor Dashboard (1/2)

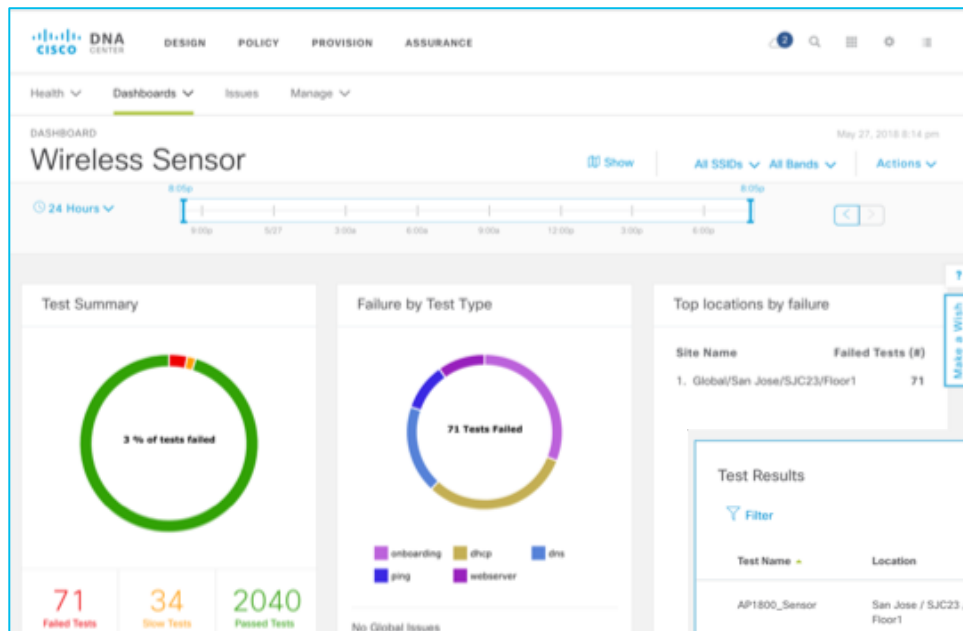

- Common filter set as Client Health Page
- Network Time Travel Navigation
- Customizable Dashlets

Total Fail / Slow Success

Failed Test Detail

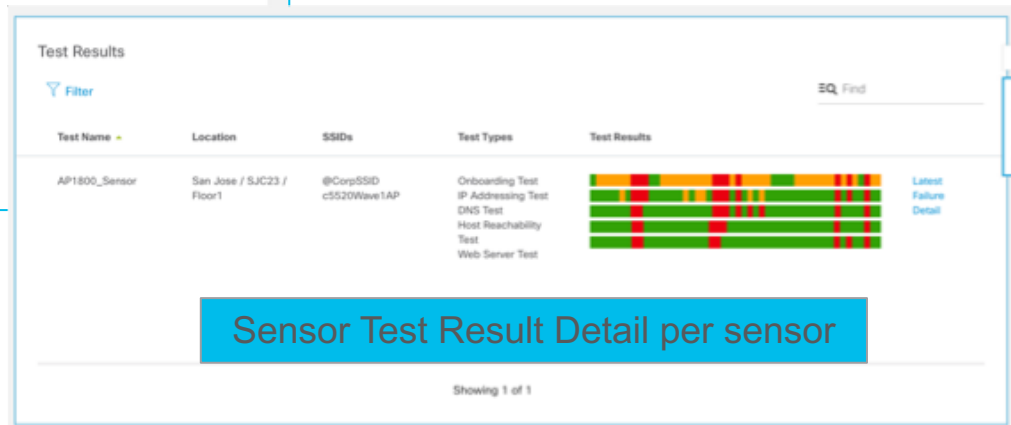

Sensor Test Result Detail per sensor

New Sensor Dashboard (2/2)

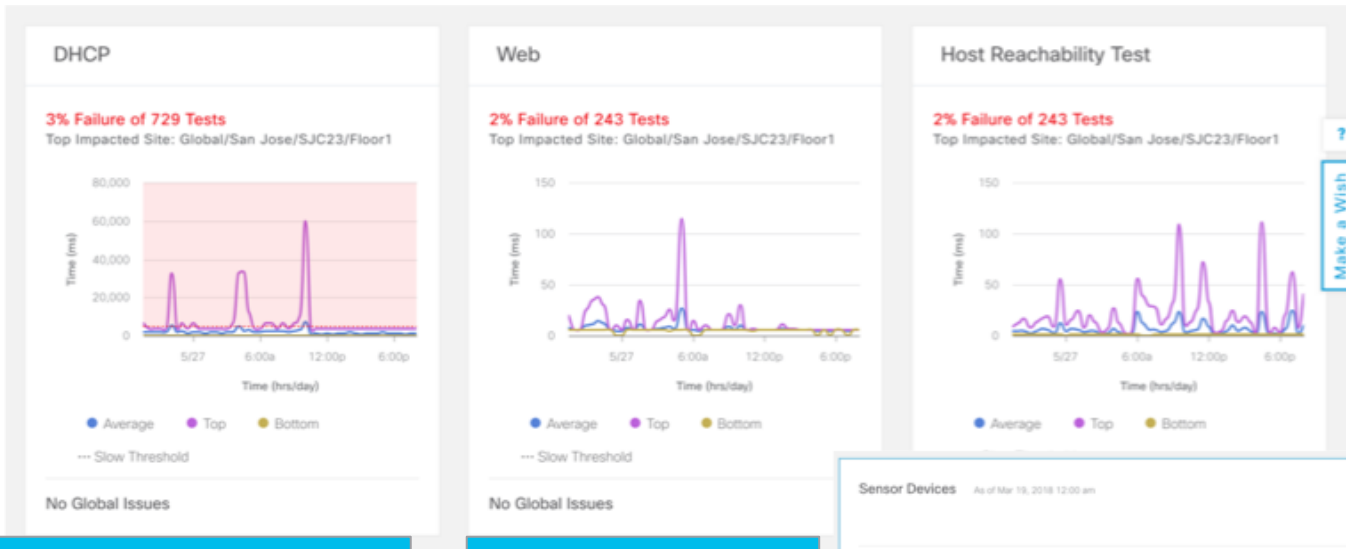

Failure %, Total Test#
 Top Impacted Location

Avg., Top, Bottom
 Slow Threshold

Aggregated Sensor
 Test View

Sensor Devices As of Mar 18, 2018 12:00 am

Filter SQ Find

Name	Type	Tests		Issue Count	Neighbor AP Count	Device Model	Location
		Total	Failed				
AP-D0	AP_AS_SENSOR	557	0	0	47	AR-AP1852I-B-K9	Global/SJC22/DNA-Lab/Floor1
AP2800	AP_AS_SENSOR	1347	1347	0	53	AR-AP2802I-B-K9	Global/SJC22/DNA-Lab/Floor1
AP3800-Sensor-on-FRA	RADIO_AS_SENSOR	162	0	0	80	AR-AP3802I-B-K9	Global/SJC22/DNA-Lab/Floor1
SENSOR_70f235a78-68-80	FARALLON	588	45	0	42	AR-AP1805S-B-K9	Global/SJC22/DNA-Lab/Floor1

Export

Intelligent packet capture

Интеллектуальный захват пакетов

Roadmap (WLC 8.8 & DNA-C 1.3)

Intelligent Capture powered by DNA will deliver Live, In-Service and Anomaly based PCAPs and a lot more



Client and App
Real-time Forensics



Hyperlocation – Real-time Client Location



Total Secure
Coverage Monitoring



Live and In-Service
Anomaly based
PCAPs



Real-Time RF and
Wi-Fi App Analytics



On-Demand VIP
Client
Troubleshooting



Real-Time Client
Tracking (~3mtr)



Real-Time Coverage
Holes on map



24*7 Spectrum
Analysis

Intelligent Capture –
Making Aironet Smarter



AP
2800/3800



AP 4800

Intelligent Capture with Real-time Client and App insights would enhance guided remediation and also allow On-Demand VIP client Troubleshooting

Intelligent Capture on Aironet will help generate better actionable insights on the DNA Center Assurance

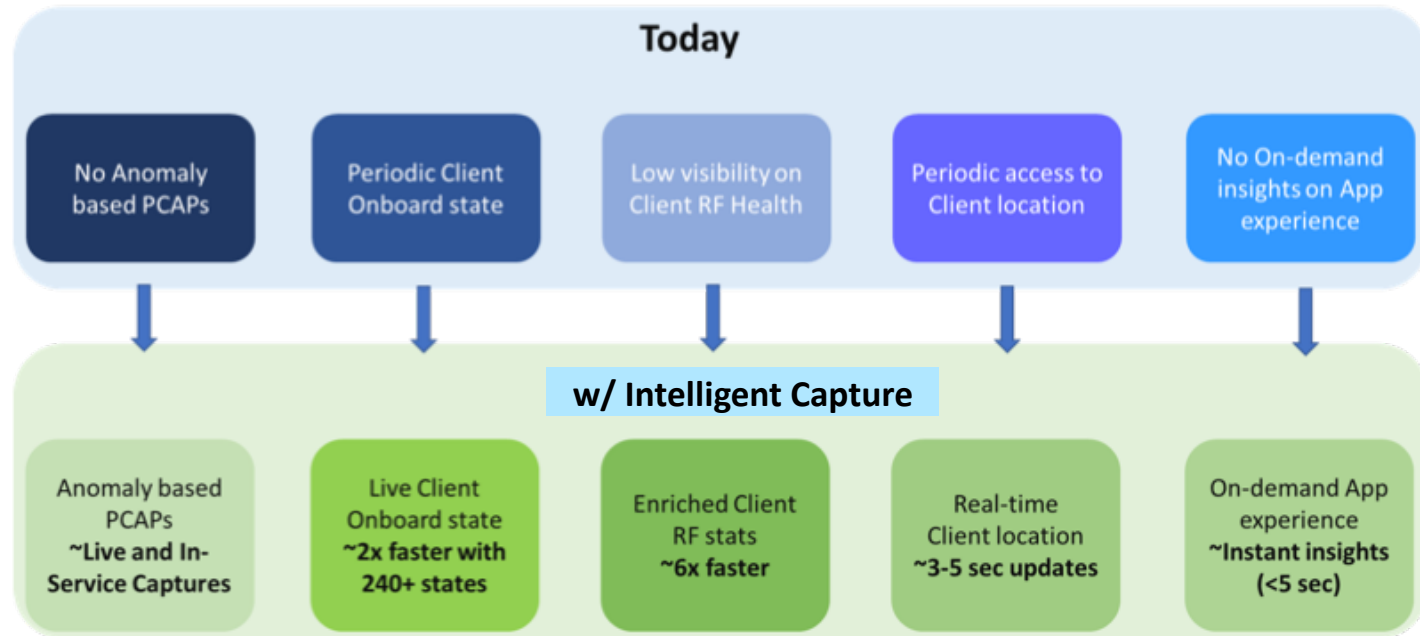
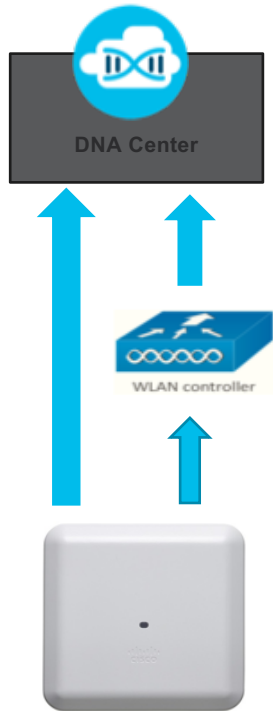

DNA Center Assurance

Intelligent Capture ~ Key Use-Cases



Made for DNA

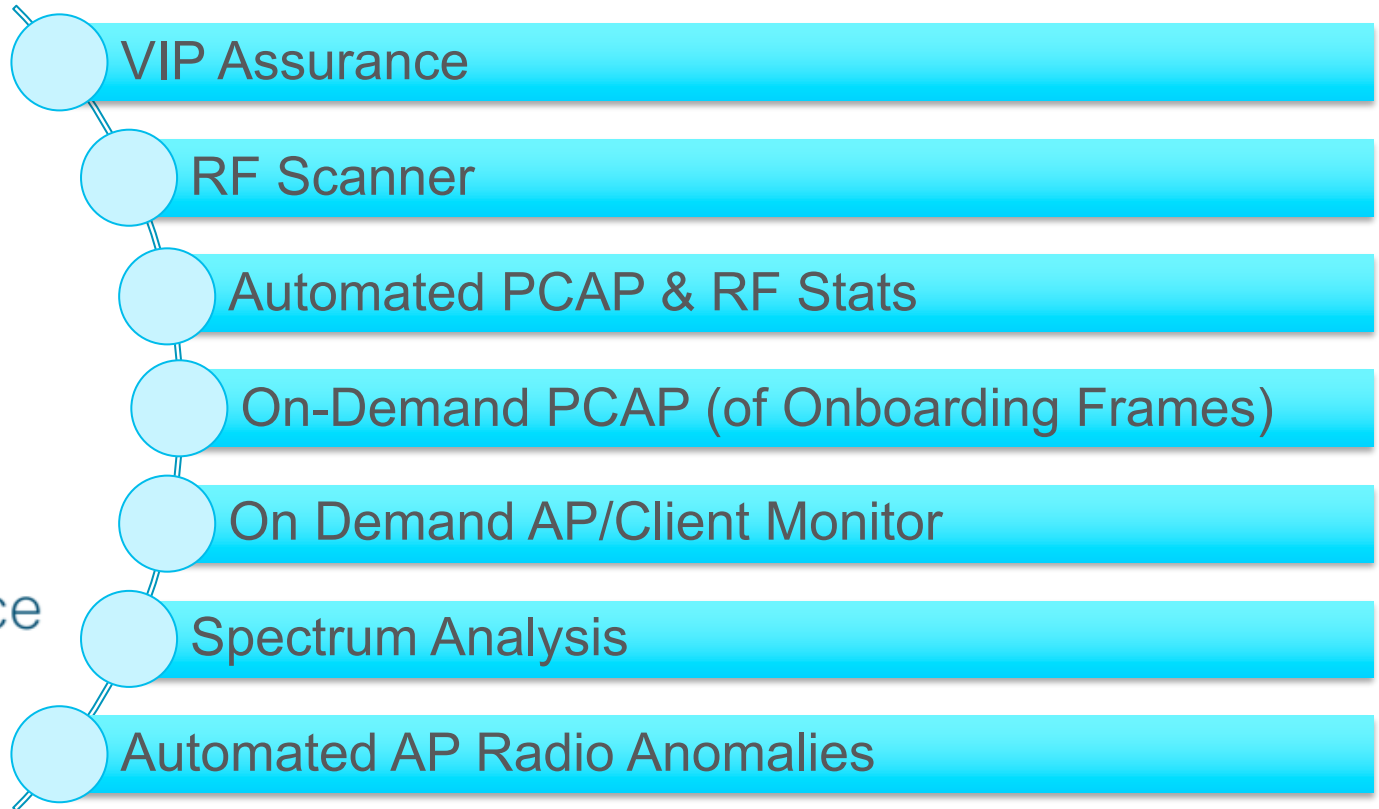

Intelligent Capture ~ Real-Time Analytics and troubleshooting tool

On-Demand

- **On-demand Intelligent Capture**
 - Real-time Event Viewer and Automated Filtered Packet capture
 - Auto Packet Analyzer
 - Real-time Client location Map
 - Real-Time Client RF Stat Graph
 - AP4800 3rd radio Full packet capture
 - Real-Time Application Analyzer integration
 - Packet Capture across multiple APs
 - Wireless Decrypted Packet Capture
- Real-Time RF Visualization with Location
- Spectrum Analyzer on DNA Assurance

Scheduled, Automated

- Real Time Client RF Stat update
- Real Time AP RF Stat update
- Multi-Device Onboarding Capture
- Client Onboarding Issue with Automated PCAP
- Radio Anomaly Issue with PCAP
- AP RF Analysis

Single Device VIP capture

Multi-Device Onboarding capture

Automated PCAP

Real-Time RF / Spectrum Analyzer

Telemetry Architectural Overview

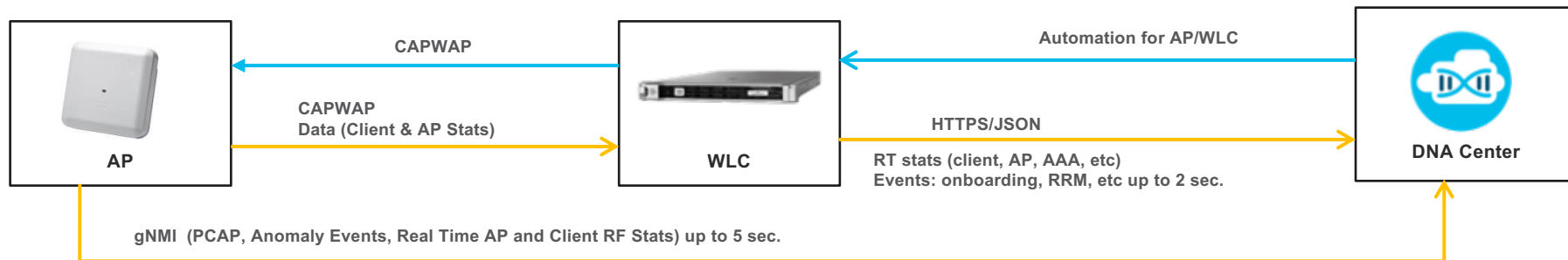

- Configuration:
 - From DNA (automation channel) to WLC
- Telemetry Data:
 - AP data exported directly to northbound system using **gNMI channel**
 - Real time Client RF stats and AP stats (programmable up to 5 sec).
 - Anomalies-based PCAP
 - Anomaly Events, Spectrum Data
 - WLC data export types using **HTTPS/JSON**
 - Events or Anomalies: onboarding, RRM, AP and AAA failure
 - KPI & Stats for Clients, AP, WLC, Rogue, Application Usages
 - Optimize Data transmission – (compression, channel-based, diff-sync, adaptive-sync)

Роуминг: как измерить сегодня?

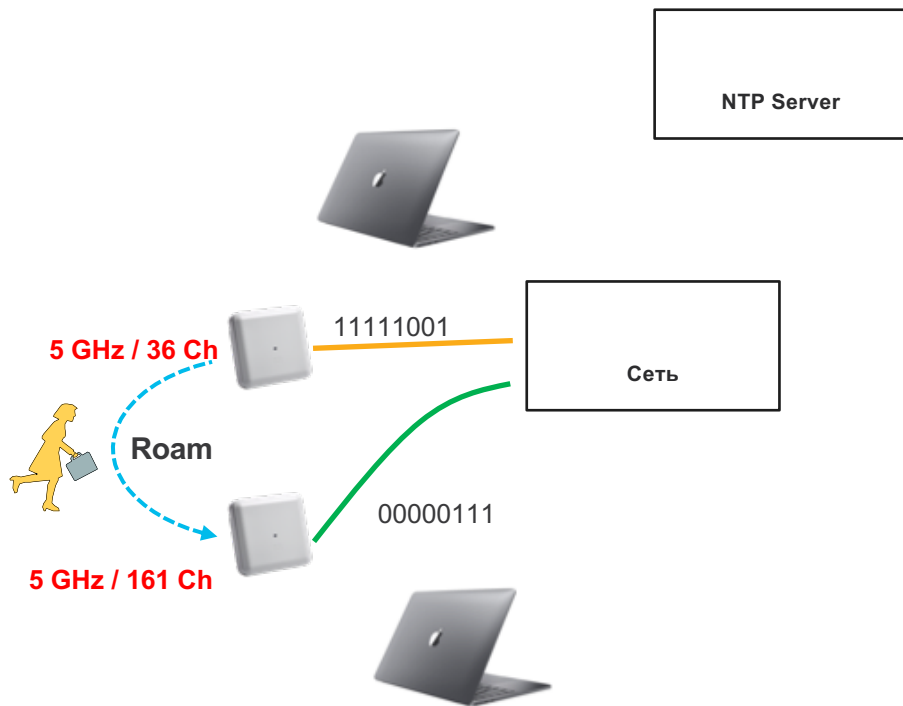

- 1-й ноутбук подключается к точке доступа А
- 2-й ноутбук подключается к точке доступа В
- Оба ноутбука синхронизированы по времени
- 1-й ноутбук захватывает последний пакет клиента для точки А
- 2-й ноутбук захватывает первый пакет клиента для точки В
- Анализируется разница во времени – время роуминга

Intelligent Capture

Automated Stitching from Multiple APs Capture

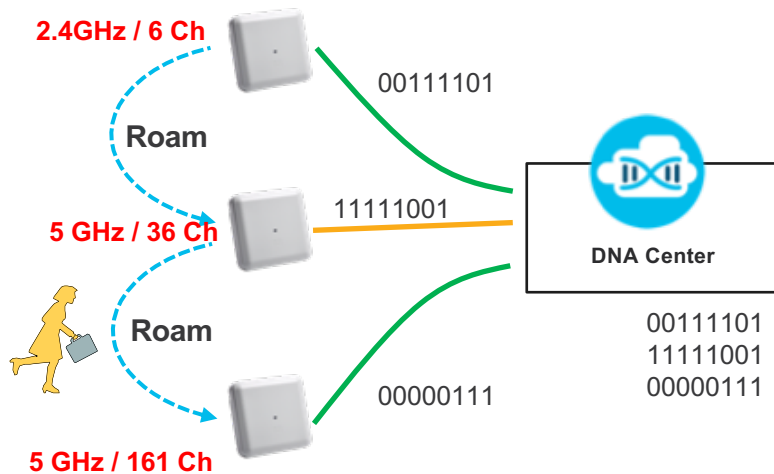

- Multiple APs tracking clients during packet capture
- Single PCAP generated upon Multiple AP roaming scenarios
- Zero Packet Loss during Client Roam
- Auto Decrypted Data Packet
- Capture Across AP, across Floor
- Pre-Scheduled Packet Capture
- Automated Packet Capture

Intelligent Capture

On-demand VIP Troubleshooting

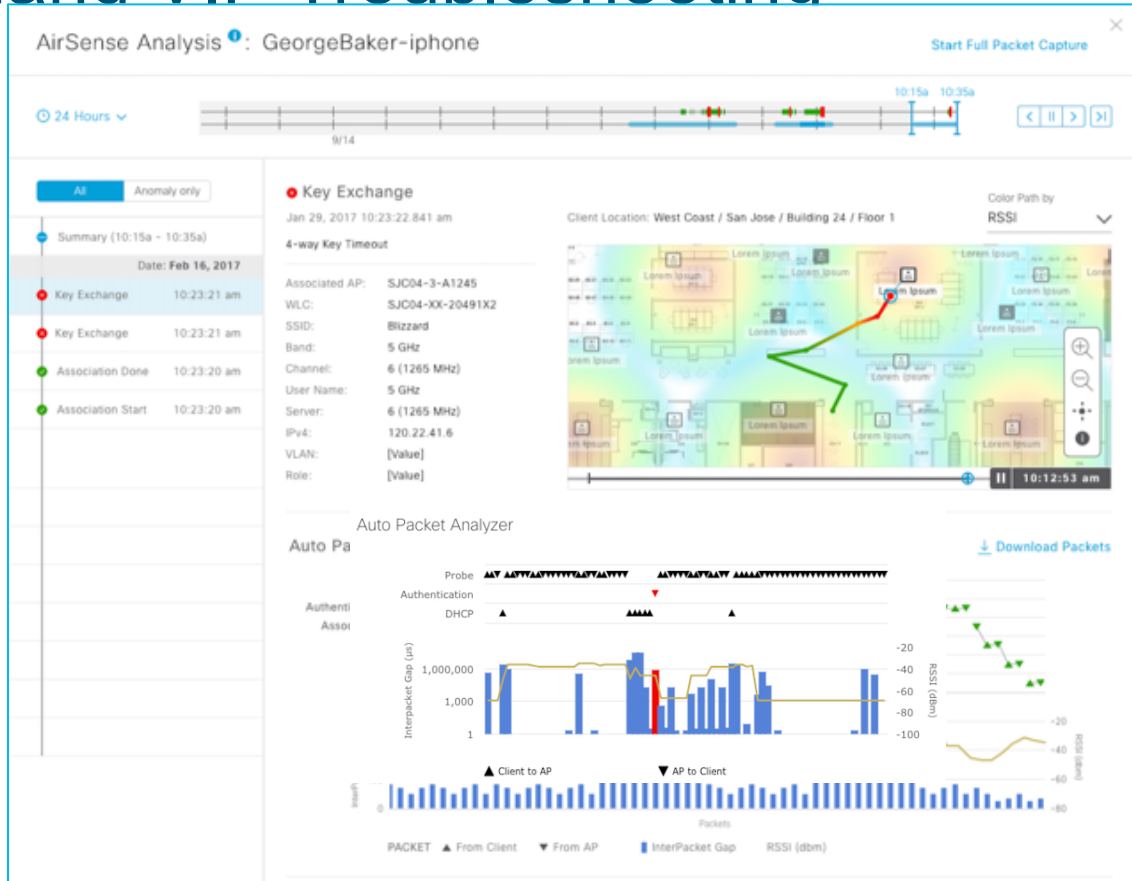

Intelligent Capture

On-demand VIP Troubleshooting

Network Time Travel view

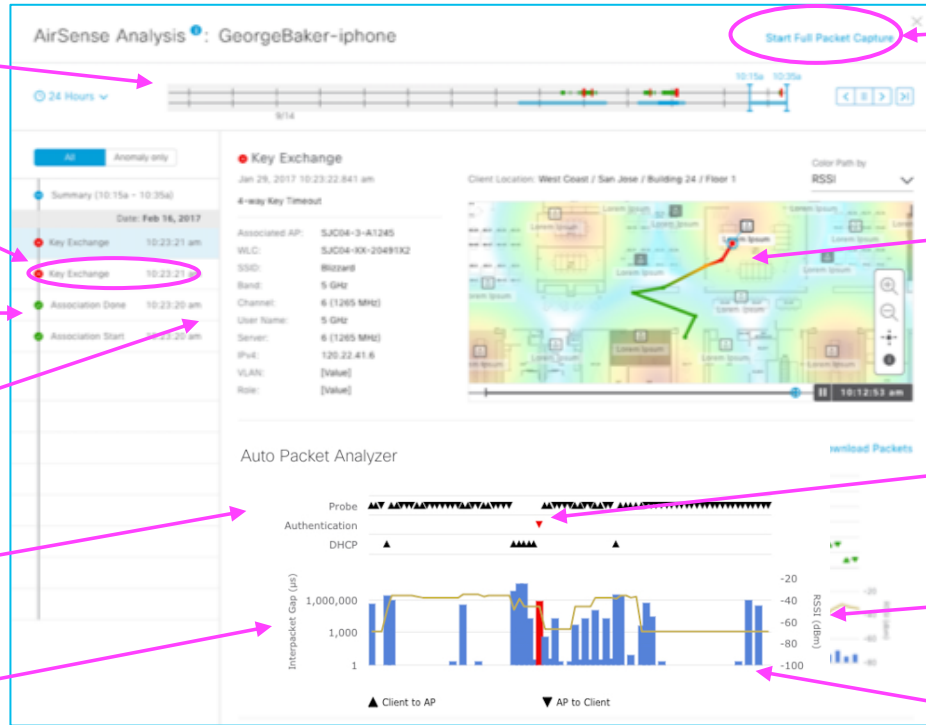

Failed Onboard

Real-time Event Viewer

Download Onboard Packet

Onboard Packet stage identifier

Auto Packet Analyzer

Start Full Packet Capture

AP4800 3rd radio Full packet capture

Real-time Client location Map with trail of movement

Failed Packet

RSSI Chart per Packet

Interpacket Gap (ms) bar chart

Actionable Insights - Intelligent Capture

Wireless client failed to connect (SSID: blizzard, AP: SJC14-21B-AP3, Band: 2.4 GHz, Site: Unknown) - Failed to authenticate due to Client Timeout

Status: Open | Last Occurred: Apr 5, 2018 1:00 PM

Description
The Clients failed to authenticate and complete the 4-way handshake because the AAA server rejected the clients.

Impact
Location: San Jose
1 Building
2 Floors
Clients
23 Wireless Clients

Intelligent Capture Analysis
AirSense anomaly triggered packet capture is off. [Change Settings](#)

Event	Reason	Date / Duration
Failure	EAP ID Timeout	30.00 sec
Auth Start		Apr 5, 2018 1:00:37 pm
Auth Done	EAP ID Timeout	Apr 5, 2018 1:00:37 pm
Send Deauth		Apr 5, 2018 1:00:37 pm

Suggested Actions (3)
1. Verify the client profile for this "blizzard" SSID to see if the profile parameters are compatible with the AAA server configuration.

4. Issue correlation with Automated PCAPs

- Anomaly based automated PCAPs captured and correlated with all Onboarding and Roaming issues

Actionable Insights - Intelligent Capture

5. On-Demand and Real-Time AP Insights

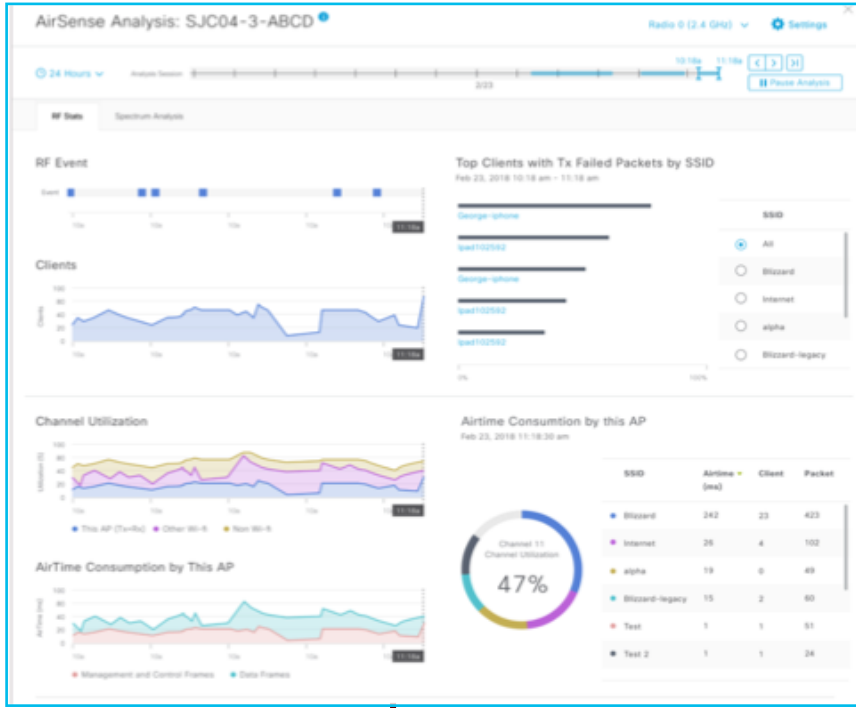



- **Real-Time AP RF Stats** (Channel Utilization, Air-Time consumption) per AP

- **In-depth view on AP RF analytics** (Tx Power, Packet Re-transmit Rate) per AP

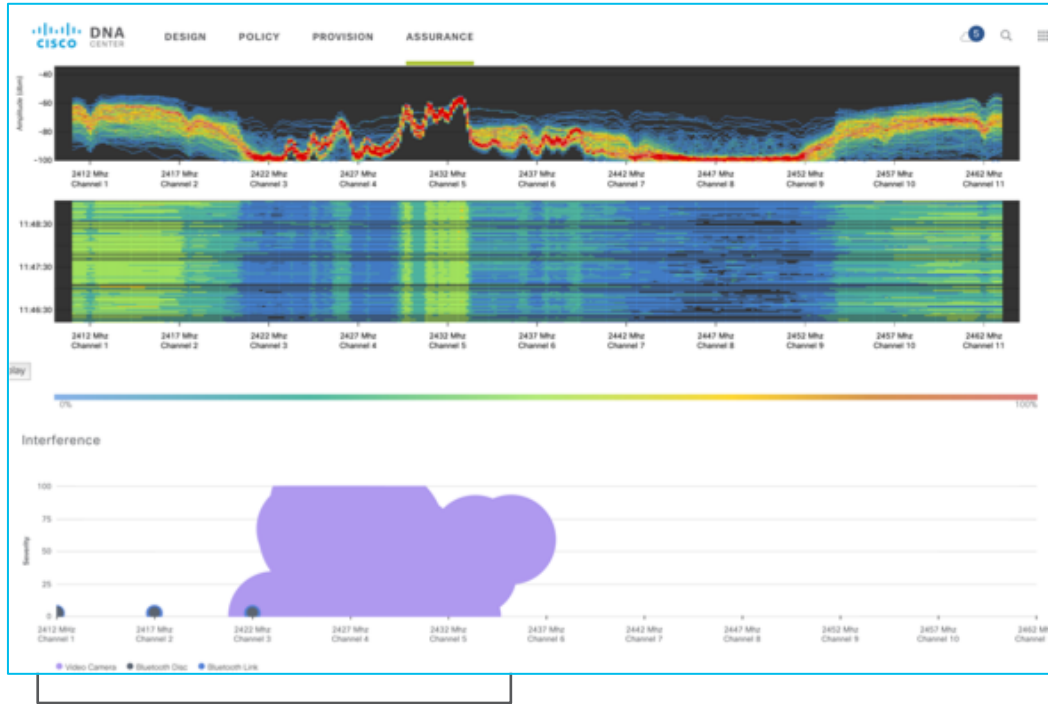
Intelligent Capture Real-Time Spectrum Analyzer.



- Powered by CleanAir 
- Highest Resolution Bandwidth 78.5 KHz per each bin 
- Persistent Spectrum Plot using Max/Duty Cycles
- Heatmap based on RF Duty Cycle
- Waterfall visualization for Swept Spectrogram Plot w/ playback function
- Interferers are classified w/ center frequency, severity and interfere bandwidth
- Running on Local/Flex and Monitor mode AP

Intelligent Capture differentiation across Aironet portfolio

	Good	Better	Best
Features	Cisco AP18XX	Cisco AP2800/3800	Cisco AP4800
Partial Packet Capture (Mgmt. frames, Data frames from Ethernet port etc.)	X	★	★
AP Radio Anomalies	X	★	★
Real-Time RF Stats (RSSI, SNR, Pkt. loss)	X	★	★
Real-time Wi-Fi Insights (Channel Utilization by traffic type etc.)	X	★	★
Full Packet Capture* (Sniffer mode per AP)	★	★	★
Full Packet Capture* (Dedicated 3 rd radio)	X	X	★
Spectrum Analysis on DNA	X	★	★

Full Packet Capture = Control frames + Data frames decrypted over the air

Что дальше?

Introducing DNA Analytics Machine Learning

DNA Analytics – Kairos

Machine Learning

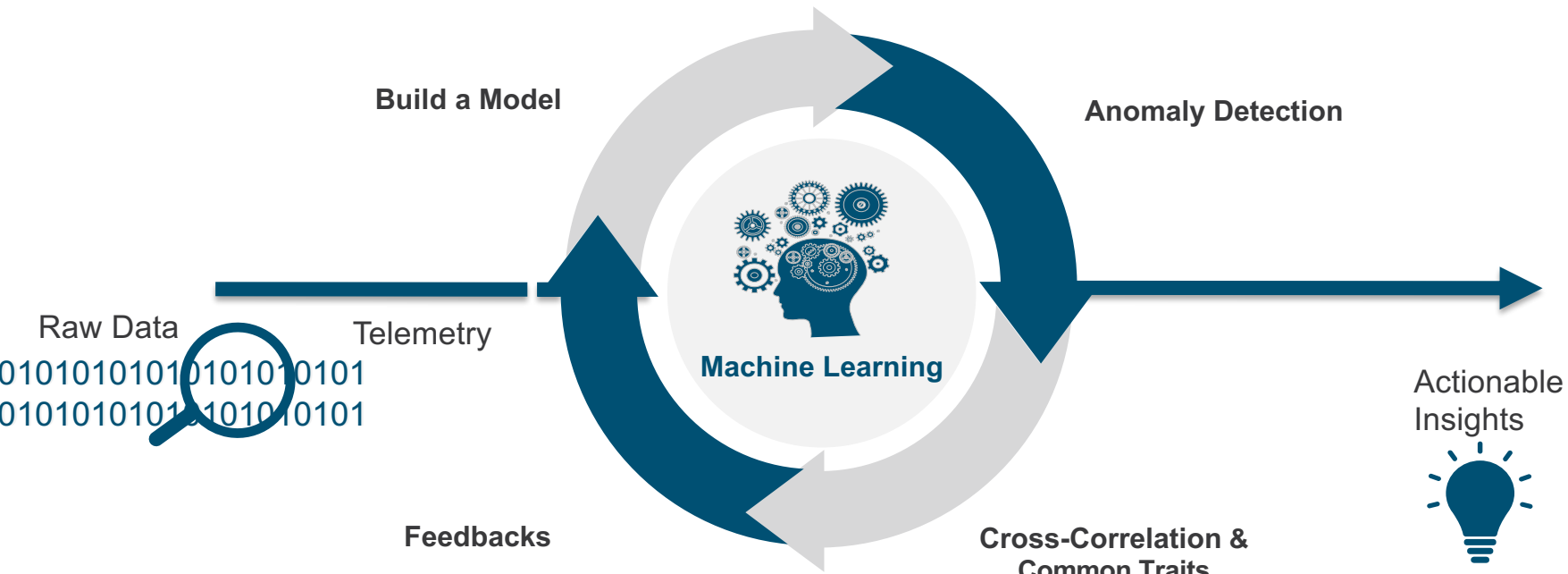

WPA3 Value Proposition

WPA3 has major improvements in four key areas:

1. Privacy on Public Wi-Fi Networks (OEW open encryption is optional)

WPA2 - open Wi-Fi networks the kind you find in public locations—are a security mess. Because they're open and allow anyone to connect, traffic sent over them isn't encrypted at all.

WPA3 -WPA3 fixes things by using “individualized data encryption”. When you connect to an open Wi-Fi network, the traffic between your device and the Wi-Fi access point will be encrypted even though you didn't enter a passphrase at the time of connection.

2. Protection Against Brute-Force Attacks

WPA2 - When a device connects to a Wi-Fi access point, the devices perform a “handshake” that ensures you've used the correct passphrase to connect and negotiates the encryption that will be used to secure the connection.

WPA3 - WPA3 defines a new handshake that “will deliver robust protections even when users choose passwords that fall short of typical complexity recommendations”. In other words, even if you're using a weak password, the WPA3 standard will protect against brute-force attacks where a client attempts to guess at passwords over and over until they find the correct one.

WPA3 Vision

3. An Easier Connection Process for Devices Without Displays (on consumer devices only)

WPA2 - Today, it's common to see Wi-Fi-enabled devices without displays. Everything from the Amazon Echo, Google Home, Smart lightbulbs etc can connect to a Wi-Fi network but without KB and Display the process is cumbersome

WPA3 - WPA3 includes a feature that promises to “simplify the process of configuring security for devices that have limited or no display interface”. It's unclear exactly how this will work, but the feature could be a lot like Hot Spot 2.0

4. Higher Security for Government, Defense, and Industrial Applications

WPA3 - The final feature isn't something that home users will care about, but the Wi-Fi Alliance also announced WPA3 will include a “192-bit security suite, aligned with the Commercial National Security Algorithm (CNSA) Suite also part of NSA. It was requested by government, defense, and industrial applications to allow stronger encryption on critical Wi-Fi networks. This will be a key FIPS requirement.

WLC	AP	Flex & Local	SDA Mode	ME Mode
8.9	11ac Wave 2	8.9	8.9	8.9

DNA Wireless Assurance powered by Cisco Aironet and Cisco DNA-Center



Active Sensor
Testing



Wi-Fi iOS
Analytics



Streaming
Telemetry



Network Time
Travel



Intelligent Capture
Auto PCAPs



Intelligent Capture
Forensics



Actionable
Insights

Guided
Remediation

Aironet Active Sensor
with proactive wireless
network test



Спасибо.
Вопросы?